

PowerEdge R320



Technical Guide



The one-socket PowerEdge R320 delivers powerful performance and enterprise-class, high-availability features in a 1U chassis.



This document is for informational purposes only. Dell reserves the right to make changes without further notice to any products herein. The content provided is as is and without express or implied warranties of any kind.

Dell, the DELL logo, PowerEdge, EqualLogic, PowerVault, OpenManage, KACE and ReadyRails are trademarks of Dell, Inc. Intel, Xeon, Celeron, and Pentium are registered trademarks and Core is a trademark of Intel Corporation in the U.S. and other countries. Microsoft, Windows, Windows Server,, BitLocker, ActiveX, Internet Explorer, and Hyper-V are either registered trademarks or trademarks of Microsoft Corporation in the United States and/or other countries. Novell and SUSE are registered trademarks of Novell, Inc. in the United States and other countries. IBM, Tivoli, and Netcool are registered trademarks of IBM in the United States. Other trademarks and trade names may be used in this document to refer to either the entities claiming the marks and names or their products. Dell disclaims proprietary interest in the marks and names of others.

©Copyright 2014 Dell Inc. All rights reserved. Reproduction or translation of any part of this work beyond that permitted by U.S. copyright laws without the written permission of Dell Inc. is unlawful and strictly forbidden. ENERGY STAR is a registered mark owned by the U.S. government.

January 2014 | Version 6.0



Table of contents

1	System overview.....	5
	Introduction.....	5
	Key technologies.....	6
2	System features.....	7
	Comparison of PowerEdge systems.....	7
	Specifications.....	8
3	Chassis views and features.....	11
	Chassis views.....	11
	Chassis features.....	12
4	Processor.....	15
	Processor features.....	15
	Supported processors.....	16
	Chipset.....	16
5	Memory.....	17
	Supported memory.....	17
	Memory configurations.....	18
	Memory speed.....	18
	Memory RAS features.....	19
6	Storage.....	21
	Internal storage.....	21
	External storage.....	21
	Storage controllers.....	22
	Optical drive.....	23
	Tape drive.....	23
7	Networking and PCIe.....	24
	Embedded NIC controller.....	24
	PCIe expansion.....	24
8	Power, thermal and acoustics.....	26
	Power consumption and energy efficiency.....	26
	Power supply units.....	27
	Thermal and acoustics.....	28
9	Rack rails and cable management.....	31
	Sliding and static rail systems.....	31
	Cable management arm.....	33
10	Operating systems and virtualization.....	34
	Supported operating systems.....	34
	Supported virtualization.....	35
11	Dell OpenManage systems management.....	36
	Systems management solutions.....	36
	OpenManage systems management.....	37
	Dell server management operations.....	42
Appendix A. Additional specifications.....		44
	Chassis dimensions and weight.....	44
	Video specifications.....	44
	Environmental specifications.....	45
	Power supply specifications.....	46
	Rack rail specifications.....	46
	USB peripherals.....	47
Appendix B. Standards compliance.....		48



Appendix C.	Additional resources.....	49
Appendix D.	System board block diagram.....	51

Tables

Table 1.	Key technologies.....	6
Table 2.	Comparing the PowerEdge R310 to PowerEdge R320.....	7
Table 3.	Technical specifications.....	8
Table 4.	Chassis features.....	12
Table 5.	Security features.....	14
Table 6.	Supported processors.....	16
Table 7.	Memory technologies supported.....	17
Table 8.	DIMMs supported.....	18
Table 9.	Memory speed capabilities.....	19
Table 10.	Memory RAS features.....	19
Table 11.	Supported hard drives.....	21
Table 12.	Supported RAID controllers.....	22
Table 13.	Hard-drive backplane options.....	23
Table 14.	PCIe slot configurations.....	24
Table 15.	Supported NICs and HBAs.....	24
Table 16.	Power tools and technologies.....	26
Table 17.	Power supply efficiency.....	28
Table 18.	Acoustical performance.....	30
Table 19.	Supported rack types.....	32
Table 20.	Primary operating system support.....	34
Table 21.	Virtualization support.....	35
Table 22.	iDRAC7 with Lifecycle Controller functions and benefits.....	37
Table 23.	Feature comparison for Basic Management, iDRAC7 Express, and iDRAC7 Enterprise.....	38
Table 24.	One-to-one and one-to-many operations.....	43
Table 25.	Supported video modes.....	44
Table 26.	Environmental specifications.....	45
Table 27.	Power supply specifications.....	46
Table 28.	Rail adjustability range.....	46
Table 29.	Industry standards documentation.....	48
Table 30.	Additional resources.....	49

Figures

Figure 1.	Front view without bezel.....	11
Figure 2.	Front view with bezel.....	11
Figure 3.	Back view.....	11
Figure 4.	Internal view.....	12
Figure 5.	LCD control panel.....	13
Figure 6.	QRL location.....	14
Figure 7.	350W power supply unit.....	28
Figure 8.	Sliding rails with optional CMA.....	31
Figure 9.	Static rails.....	32
Figure 10.	Dell systems management solutions.....	36
Figure 11.	Systems management server lifecycle.....	42
Figure 12.	System dimensions.....	44
Figure 13.	R320 system board block diagram.....	51



1 System overview

Introduction

The one-socket Dell™ PowerEdge™ R320 rack server delivers powerful performance and enterprise-class, high-availability capabilities in a 1U chassis. The R320's configuration flexibility, increased internal storage, and straightforward systems management make it an excellent fit for web hosting and serving, file and print serving, and other general-purpose applications in space-constrained locations.

Enterprise features, scalable expandability and value in a dense chassis

The R320 features the scalable performance of the Intel® Xeon® processor E5-2400 and E5-2400 v2 product families with enterprise-class memory reliability, availability, serviceability (RAS) features. This server complements its processors with six DIMM slots and two PCI Express® (PCIe) slots, providing a substantial memory footprint and wide I/O bandwidth to support memory-intensive applications and databases as well as consolidation and virtualization. For users not needing the enterprise-class high performance of the Intel Xeon processor E5-2400 and E5-2400 v2 product families, the R320 also supports the more price-sensitive Intel Xeon processor E5-1410 and Intel Pentium® processor 1400 product family.

Users selecting the Intel Xeon processor E5-2400 and E5-2400 v2 product families can choose to implement advanced memory protection capabilities (memory sparing and memory mirroring) previously not seen in the one-socket x86 server space. These capabilities are not possible with the Intel Xeon processor E5-1410 and the Intel Pentium processor 1400 product family. Regardless of the processor type, you can take advantage of other high availability features offered on the R320. To protect your virtualized workloads, the R320 offers redundant SD cards making your hypervisors redundant and failsafe. Other reliability and availability features include hardware and software RAID options, hot-plug hard drives and hot-plug power supplies.

Ideal for your applications

The R320 features up to 100% more processor cores, enterprise-class RAS features including memory sparing and memory mirroring, and 100% more internal hard drives than the previous-generation R310. Network options span multiple third-party brands and adapter types with 10GbE NIC, 10GbE FCoE, and Fibre Channel 8Gb HBA. The R320 delivers failsafe hypervisors to protect virtualized workloads and Dell Fresh Air compliant configurations, enabling it to operate in extended temperature ranges. This not only helps to save energy costs but also allows the R320 to ride through unforeseen events such as power brownouts. Its innovative, agent-free systems management delivers no-compromise, enterprise-class systems management for hassle-free computing. These combined capabilities make the R320 an excellent fit for web hosting and serving, file and print serving, and work group collaboration and productivity applications, especially where the low profile of a 1U chassis is desired.

Simplified systems management, without compromise

The Dell OpenManage™ systems management portfolio includes Integrated Dell Remote Access Controller 7 (iDRAC7) with Lifecycle Controller. This embedded feature helps IT administrators manage Dell servers in physical, virtual, local and remote environments, operating in-band or out-of-band, with or without a systems management software agent installed.

OpenManage iDRAC with Lifecycle Controller integrates and connects to leading third-party systems management solutions (such as those from Microsoft, VMware and BMC Software), so users

can maintain a single point of control and capitalize on an existing systems management investment. OpenManage simplifies the lifecycle of deploying, updating, monitoring and maintaining Dell PowerEdge servers.

Key technologies

Table 1 summarizes key technologies used in the Dell PowerEdge R320 rack server.

Table 1. Key technologies

New technology	Detailed description
New Intel processors	The new Intel Xeon processor E5-2400 and E5-2400 v2 product families, the Intel Xeon E5-1410 processor, and the Intel Pentium processor 1400 product family offer features such as embedded PCIe lanes for improved I/O performance. See the Processor section for details.
Intel C600 series chipset	The Intel Platform Controller Hub (PCH) chip is implemented on the R320 server.
Next-generation PERC options	The R320 supports the new PERC controller cards with improved functionality and faster performance. See the Storage section for details.
PERC S110 software RAID solution	This new software RAID solution supports RAID 0, 1, 5 and 10, and supports a maximum of four hot-plug SATA hard drives or SATA solid-state drives. See the Storage section for details.
iDRAC7 with Lifecycle Controller	The second generation embedded systems management solution for Dell servers provides agent-free hardware and firmware inventory and alerting, in-depth memory alerting, faster performance, a dedicated gigabit port, and many more features. See the Dell OpenManage systems management section for details.
Advanced power management	The R320 supports advanced power monitoring and power capping tools that can help manage power consumption. See the Power, thermal and acoustics section for details.
Fresh Air cooling	Dell has tested and validated an integrated data center solution that enables you to operate at higher temperatures or even chiller-less. See the Power, thermal and acoustics section for details.
Failsafe hypervisors	The internal dual SD module enables Dell's unique Failsafe Virtualization architecture, ensuring uptime by providing failover capability for embedded hypervisors, such as VMware® vSphere® ESXi™ and Microsoft Windows Server 2012 Hyper-V.
Fault-tolerant fans	Failure of one fan rotor is tolerated with degradation in performance through active throttling and increased fan speeds. The feature helps reduce downtime by allowing you to schedule a fan replacement within 360 hours of a fan failure.



2 System features

Compared to the previous generation of PowerEdge R310, the R320 supports up to 100% more processor cores, enterprise-class RAS features including memory sparing and memory mirroring, 100% more internal hard drives, innovative systems management delivered by iDRAC7 with Lifecycle Controller, and has a Dell Fresh Air compliant configuration available. Table 2 compares some of the features of the R320 to its R310 predecessor. Table 3 lists all of the R320's specifications.

Comparison of PowerEdge systems

The R320 is the new generation PowerEdge server replacing the R310. Table 2 compares some of the R320 features to those of the R310.

Table 2. Comparing the PowerEdge R310 to PowerEdge R320

Feature	PowerEdge R310	PowerEdge R320
Chassis	1U rack	1U rack
Processors	Intel Xeon processors 3400 series Intel Core™ i3 processor 500 series Intel Pentium® G6950 Intel Celeron® G1101	Intel Xeon processor E5-2400 and E5-2400 v2 product families Intel Xeon processor E5-1410 Intel Pentium processor 1400 product family
Internal interconnect	Intel DMI	Intel DMI 2.0
Memory¹	4 x 1333 DDR3 UDIMM or 6 x 1333 DDR3 RDIMM Up to 32GB	6 x DDR3 RDIMM and UDIMM Up to 192GB
Hard drive bays (hot-plug)	Up to 4 x 3.5" cabled or hot-plug	Up to 4 x 3.5" cabled or hot-plug Up to 8 x 2.5" hot-plug
RAID controller	PERC 6/i, SAS6/iR, PERC6/E, S100, S300, H200, H700, H800	PERC S110, H310, H710, H810
PCI slots	2 PCIe 2.0 slots	1 PCIe 3.0 slot and 1 PCIe 2.0 slot
Embedded NICs	Broadcom® Dual Port 1GbE LOM	Broadcom Dual Port 1GbE LOM
Power supplies	Non-redundant 350W Redundant 400W	Non-redundant 350W Redundant 350W Redundant 550W
Dell OpenManage Systems Management	Dell OpenManage Lifecycle Controller 1.x iDRAC6 (Express or Enterprise) with Lifecycle Controller	OpenManage Essentials OMSA Agent OpenManage Power Center (requires iDRAC7 Enterprise with Lifecycle Controller) OpenManage Integrations and Connections Basic management (standard option)
Power efficiency	Silver	Platinum



Feature	PowerEdge R310	PowerEdge R320
Availability	Hot-plug drives Hot-plug redundant power supply units	Hot-plug drives Hot-plug redundant power supply units Memory sparing and memory mirroring Internal dual SD module

¹GB means 1 billion bytes and TB equals 1 trillion bytes; actual capacity varies with preloaded material and operating environment and will be less.

Specifications

Table 3 summarizes the specifications for each of the PowerEdge R320 features. For the latest information on supported features for the PowerEdge R320, visit Dell.com/PowerEdge.

Table 3. Technical specifications

Feature	PowerEdge R320 technical specification
Form factor	1U rack
Processors	Intel Xeon processor E5-2400 and E5-2400 v2 product families Intel Xeon processor E5-1410 Intel Pentium processor 1400 product family
Processor socket	1 socket
Front side bus	Intel DMI 2.0
Cache	2.5MB per core with core options of 2, 4, 6, 8 or 10
Chipset	Intel C600
Memory ¹	Up to 192GB (6 DIMM slots): 2GB/4GB/8GB/16GB/32GB DDR3 up to 1600MT/s
PCIe slots	2 PCIe slots <ul style="list-style-type: none"> 1 x8 slot with x4 bandwidth, 2.0, half-height, half-length 1 x16 slot with x16 bandwidth, 3.0, full-height, half-length
RAID controller	Internal controllers: PERC S110 (SW RAID) PERC H310 PERC H710 External HBAs (RAID): PERC H810 External HBAs (non-RAID): 6Gbps SAS HBA
Hard drives	Drive bay options: 4 x 3.5" cabled SAS or SATA drives 4 x 3.5" hot-plug SAS, SATA or SSD drives (2.5" hybrid kit available) 8 x 2.5" hot-plug SAS, SATA or SSD drives Hot-plug hard drive options: 2.5" SATA, nearline SAS, SAS (15K, 10K), SAS SSD, SATA SSD 3.5" SATA, nearline SAS, SAS (15K) Self-encrypting drives available Cabled hard drive options: 3.5" SATA, nearline SAS, SAS (15K)
Embedded NIC	Broadcom 5720 Dual Port 1GbE LOM
I/O adapter options	1Gb Ethernet: Broadcom 5720 Dual Port 1Gb NIC



Feature	PowerEdge R320 technical specification
	Broadcom 5719 Quad Port 1Gb NIC Intel I350 Dual Port 1Gb stand-up adapter Intel I350 Quad Port 1Gb stand-up adapter 10Gb Converged Ethernet: Brocade® BR1020 Dual Port 10Gb CNA QLogic® QLE8262 Dual Port 10Gb DA/SFP+ Broadcom 57810S Dual Port 10Gb Base-T CNA Broadcom 57810S Dual Port 10Gb DA/SFP+ CNA 10Gb Ethernet: Intel X520 Dual Port 10Gb DA/SFP+ server adapter Intel X540 Dual Port 10Gb Base-T adapter FC8/FC4 HBA: QLogic QLE2460 4Gb Single Port FC HBA QLogic QLE2462 4Gb Dual Port FC HBA QLogic QLE2560 8Gb Single Port FC HBA QLogic QLE2562 8Gb Dual Port FC HBA Emulex® LPe-12000-E 8Gb Single Port FC HBA Emulex LPe-12002-E 8Gb Dual Port FC HBA Brocade 815 8Gb Single Port FC HBA Brocade 825 8Gb Dual Port FC HBA
Power supply	Platinum efficiency 350W or 550W power supply Bronze efficiency cabled 350W power supply Auto-ranging power supplies
Availability	High-efficiency, hot-plug, redundant power supplies; hot-plug hard drives; TPM/No-TPM; dual internal SD support; optional bezel; information tag; ECC memory; interactive LCD screen; extended power range; ENERGY STAR® Server 1.0 qualified.
Dell OpenManage Systems Management (Agent-free or with OpenManage Server Administrator [OMSA] Agent)	<ul style="list-style-type: none"> • OpenManage Essentials • OMSA Agent • OpenManage Power Center (requires iDRAC7 Enterprise with Lifecycle Controller) • OpenManage Integrations and Connections: <ul style="list-style-type: none"> – OpenManage Integration Suite for Microsoft® System Center – OpenManage Integration for VMware vCenter – Connections for HP® Operations Manager, IBM® Tivoli® Netcool® and CA Network and Systems Management • Basic management (standard option) <ul style="list-style-type: none"> – Upgrade to iDRAC7 (Express or Enterprise) with Lifecycle Controller – Upgrade to 8GB vFlash media or 16GB vFlash media for iDRAC7 Enterprise with Lifecycle Controller – Trial evaluations available for iDRAC7 (Express and Enterprise) with Lifecycle Controller
Rack support	<ul style="list-style-type: none"> • ReadyRails™ II sliding rails for tool-less mounting in 4-post racks with square or unthreaded round holes or tooled mounting in 4-post threaded hole racks, with support for optional tool-less cable management arm • ReadyRails static rails for tool-less mounting in 4-post racks with square or unthreaded round holes or tooled mounting in 4-post threaded and 2-post (Telco) racks
Operating systems	Microsoft® Windows Server® 2012 R2 (includes Hyper-V®)



Feature

PowerEdge R320 technical specification

Microsoft Windows Server 2012
Microsoft Windows Server 2012 Essentials
Microsoft Windows Server 2008 R2 SP1, x64 (includes Hyper-V®)
Microsoft Windows® Small Business Server 2011
Novell® SUSE® Linux Enterprise Server
Red Hat® Enterprise Linux®

Virtualization options:

Citrix® XenServer®
Microsoft Hyper-V, a server role in Microsoft Windows Server operating systems
VMware vSphere including ESXi™
Red Hat Enterprise Virtualization®
For more information on the specific versions and additions, visit
Dell.com/OSsupport.

¹GB means 1 billion bytes and TB equals 1 trillion bytes; actual capacity varies with preloaded material and operating environment and will be less.



3 Chassis views and features

The Dell PowerEdge R320 is a 1U, 1-socket rack server. For additional system views and features, see the *Dell PowerEdge R320 Systems Owner's Manual* on Dell.com/Support/Manuals.

Chassis views

Figure 1 shows the features on the front of the R320 chassis including four 3.5-inch hard drives, control panel, USB connectors and many other components and features described in this guide.

Figure 1. Front view without bezel



Figure 2 shows the optional locking bezel on the front of the R320 chassis.

Figure 2. Front view with bezel



Figure 3 shows the features on the back panel of the R320 including USB connectors, Ethernet connectors, serial connector, video connector, PCIe slots, power supplies and many other components and features described in this guide.

Figure 3. Back view



The chassis design of the R320 is optimized for easy access to components and for airflow for effective and efficient cooling. The R320 supports up to six DIMMs, one processor, hot-plug redundant power supplies, and many other components and features described in this guide.



Figure 4. Internal view



Chassis features

Table 4 lists the features on the R320 chassis. For additional information, see the *Dell PowerEdge R320 Systems Owner's Manual* on Dell.com/Support/Manuals.

Table 4. Chassis features

Feature	Description
Power button	ACPI-compliant power button with an integrated green power LED
Front bezel	Covers the system's front-loading hard drives and locks for security
NMI button	Used to troubleshoot software and device driver errors; use only if directed to do so by qualified support personnel or by the operating system's documentation
System identification button	Buttons on the back and front of a system to help identify the unit in a data center environment
Hard drives	Up to eight 2.5-inch drives
USB connectors	Connects USB devices to the server
Information tag	Slide-out label panel for recording system information



Feature	Description
Video connector	Connects a monitor to the server
LCD panel and buttons	Displays system ID, status information, and system error messages; two navigation buttons to scroll through the menu on the LCD and one select button
Optical drive	Optional slim DVD or DVD+RW drive
Power supply units	Supplies power to the server
Power supply indicators	Indicates whether server has power
NIC indicators	Indicates network activity and status
PCIe slots	Connects PCIe expansion cards to the server
Ethernet connectors	Connects integrated 10/100/1000 NICs to the server
Serial connector	Connects a serial device to the server
iDRAC7 Enterprise port	Dedicated management port for optional iDRAC Ports card

Front control panel

The R320 control panel is located on the front of the chassis as shown in Figure 5. For more information about the LCD control panel, see the *Dell PowerEdge R320 Systems Owner's Manual* on Dell.com/Support/Manuals.

Figure 5. LCD control panel



Quick Resource Locator

Dell PowerEdge 12th generation servers feature a Quick Resource Locator (QRL) — a model-specific Quick Response (QR) code that is located inside the R320 chassis cover (see Figure 6). Use your smartphone to access the Dell QRL app to learn more about the server.



Figure 6. QRL location



This QRL code allows you to:

- View step-by-step videos, including overviews of system internals and externals, as well as detailed, concise, task-oriented videos and installation wizards
- Locate reference materials, including searchable owner’s manual content, LCD diagnostics and an electrical overview
- Look up your service tag so you can quickly gain access to your specific hardware configuration info and warranty information
- Contact Dell directly (by link) to get in touch with technical support and sales teams and provide feedback to Dell

These codes provide an easy way to retrieve the critical support information you need when you need it, making you more efficient and effective in managing your hardware.

Security features

The latest generation of PowerEdge servers has the features listed in Table 5 to help ensure the security of your data center.

Table 5. Security features

Security feature	Description
Cover latch	A tooled latch is integrated on the top cover with a coin key lock to secure the system.
Bezel	An optional metal bezel is mounted to the chassis front to provide the Dell ID. A lock on the bezel is used to protect un-authorized access to hard drives. System status is viewable on the LCD screen when the bezel is installed.
TPM	The Trusted Platform Module (TPM) is used to generate/store keys, protect/authenticate passwords, and create/store digital certificates. It also supports the Intel Xeon TXT functionality. TPM can also be used to enable the BitLocker™ hard drive encryption feature in Windows Server 2008. TPM 1.2 is supported. No TPM version is available for China or Russia.
Power-off security	BIOS has the ability to disable the power button function.
Intrusion alert	An internal switch is used to detect chassis intrusion.
Secure mode	BIOS has the ability to enter a secure boot mode through system setup. This mode includes the option to lock out the power and NMI switches on the control panel or set up a system password.



4 Processor

The Dell PowerEdge R320 features a variety of Intel processor options. The Intel Xeon processor E5-2400 and E5-2400 v2 product families offer an ideal combination of performance, dependability and cost. These processors provide substantial performance and capacity for entry and mainstream workloads. In addition to providing raw performance gains, improved I/O is also made possible with Intel Integrated I/O, which can reduce latency by adding more lanes and doubling bandwidth. This helps to reduce network and storage bottlenecks, unleashing the processor's performance capabilities.

In addition to the Intel Xeon processor E5-2400 and E5-2400 v2 product families, the R320 supports the Intel Xeon E5-1410, which provides a balance of performance, value, and advanced features, and the Intel Pentium processor 1400 product family, which is cost-efficient and provides the basic features.

Processor features

The new Intel processors provide the following features:

- Up to ten execution cores per processor
- Intel Hyper-Threading technology enables up to 16 computational threads
- Micro-architecture on 32nm process for greater performance per watt
- Support for more memory — up to six DIMM slots and support for up to 32GB DIMMs, increasing the memory capacity from 32GB to 192GB
- Integrated memory controller with three channels of DDR3 and 46-bit physical addressing facilitate greater memory capacity
- Up to 24 PCIe 3.0 links capable of 8.0GT/s
- Faster connections throughout the system with support for up to DDR3 1600MT/s memory and 8.0GT/s QPI
- Intel Data Direct I/O (DDIO) allows I/O traffic to skip the main system memory and be directed straight to the processor cache, which can provide a significant reduction in latency as well as allowing memory to remain in a low-power state
- High bandwidth, low latency, bidirectional ring interconnect allows faster access to up to 20MB multi-banked last level cache
- Intel Advanced Vector Extensions offer up to double the floating point operations per clock cycle by doubling the length of registers, which can be useful for addressing very complex problems or dealing with large-number calculations, which are integral to many technical, financial and scientific computing problems
- Intel Turbo Boost Technology 2.0, which allows processor cores to run faster than the base operating frequency if it's operating below power, current and temperature specification limits, delivers up to double the boost than the previous generation
- Continued improvements to both Intel TXT and AES-NI help to better protect systems and data

For more information on the Intel Xeon processors, visit Intel.com.



Supported processors

Table 6 lists the Intel Xeon processors supported by the PowerEdge R320. For the latest information on supported processors, visit Dell.com/PowerEdge.

Table 6. Supported processors

Model	Speed	TDP	Cache	Cores/ threads	Max memory speed	Turbo
Xeon E5-2470	2.3GHz	95W	20MB	8/16	1600MT/s	Yes
Xeon E5-2470 v2	2.4GHz	95W	25MB	10/20	1600MT/s	Yes
Xeon E5-2440	2.4GHz	95W	15MB	6/12	1333MT/s	Yes
Xeon E5-2440 v2	1.9GHz	80W	20MB	8/16	1333MT/s	Yes
Xeon E5-2430L	2.0GHz	60W	15MB	6/12	1333MT/s	Yes
Xeon E5-2430	2.2GHz	95W	15MB	6/12	1333MT/s	Yes
Xeon E5-2420	1.9GHz	95W	15MB	6/12	1333MT/s	Yes
Xeon E5-2420 v2	2.2GHz	80W	15MB	6/12	1333MT/s	Yes
Xeon E5-2450 v2	2.5GHz	95W	20MB	8/16	1600MT/s	Yes
Xeon E5-2450	2.1GHz	95W	20MB	8/16	1600MT/s	Yes
Xeon E5-2450L v2	1.7GHz	60W	25MB	10/20	1600MT/s	Yes
Xeon E5-1410	2.8GHz	80W	10MB	4/8	1333MT/s	Yes
Xeon E5-2407	2.4GHz	80W	10MB	4/4	1066MT/s	N/A
Xeon E5-2407 v2	2.4GHz	80W	10MB	4/4	1066MT/s	N/A
Xeon E5-2403	1.8GHz	80W	10MB	4/4	1066MT/s	N/A
Xeon E5-2403 v2	1.8GHz	80W	10MB	4/4	1066MT/s	N/A
Xeon E5-2430L v2	2.4GHz	60W	15MB	6/12	1333MT/s	Yes
Xeon E5-2430 v2	2.5GHz	80W	15MB	6/12	1066MT/s	Yes
Pentium 1407	2.8GHz	80W	5MB	2/2	1066MT/s	N/A
Pentium 1403	2.6GHz	80W	5MB	2/2	1066MT/s	N/A

For information on processor installation and configuration, see the *Dell PowerEdge R320 Systems Owner's Manual* on Dell.com/Support/Manuals.

Chipset

The Intel C600 chipset is implemented on the PowerEdge R320. For more information, visit Intel.com.



5 Memory

The large memory footprint of the Dell PowerEdge R320 offers greater capacities, higher frequencies and more flexibility. The R320 supports up to 192GB of memory (6 DIMM slots) and speeds of up to 1600MT/s, providing high performance in a variety of applications. The new RAS features like memory mirroring and sparing help you increase your uptime and reduce data loss. RAS aids in the rapid and accurate diagnosis of faults that require service, increasing your memory reliability.

Supported memory

The R320 supports the memory technologies shown in Table 7.

Table 7. Memory technologies supported

Feature	UDIMM	RDIMM
Register	No	Yes
Buffer	No	No
Frequencies*	1600MT/s	1333 or 1600MT/s
Ranks supported	1 or 2	1, 2, or 4
Capacity per DIMM	2 or 4GB	2, 4, 8, 16, or 32GB
Maximum DIMMs per channel	2	2
DRAM technology	x8	x4 or x8
Temperature sensor	Yes	Yes
Error Correction Code (ECC)	Yes	Yes
Single Device Disable Code (SDDC)	Yes (with advanced ECC mode)	Yes
Address parity	Yes	Yes

*Although the R320 supports DIMM speeds lower than 1600MT/s, you can only purchase this system with DIMM speeds of 1333MT/s and 1600MT/s on Dell.com/PowerEdge.



The R320 supports the DIMMs listed in Table 8. For the latest information on supported memory, visit Dell.com/PowerEdge.

Table 8. DIMMs supported

Capacity (GB)	Speed (MT/s)	Type	Ranks per DIMM	Data width	SDDC support	Voltage
2	1600	UDIMM	1	x8	Advanced ECC	1.35
2	1600	RDIMM	1	x8	Advanced ECC	1.35
4	1600	RDIMM	2	x8	Advanced ECC	1.35
4	1600	UDIMM	1	x8	Advanced ECC	1.35
4	1600	UDIMM	2	x8	Advanced ECC	1.35
4	1600	RDIMM	1	x8	Advanced ECC	1.35
8	1600	RDIMM	1	x4	All modes	1.35
8	1600	RDIMM	2	x4	All modes	1.35
16	1600	RDIMM	2	x4	All modes	1.35
16	1600	RDIMM	2	x4	All modes	1.35
32	1333	RDIMM	4	x4	All modes	1.35

Memory configurations

Flexible memory configurations are supported on the R320, ranging from capacities of 2GB to 192GB. The system supports up to six DIMMs per processor. The R320 has three memory channels per processor, with each channel supporting up to two DIMMs.

The R320 supports a flexible memory configuration according to these basic rules:

- Speed: If DIMMs of different speeds are mixed, all channels across all processors operate at the slowest DIMM's common frequency.
- DIMM type: Only one type of DIMM can be used in a system. UDIMMs and RDIMMs cannot be mixed.

The following additional memory population guidelines apply to the R320:

- Up to two quad-rank (QR), dual-rank (DR), or single-rank (SR) DIMMs may be populated per channel.
- DIMMs must be installed in each channel, starting with the DIMM farthest from the processor.
- DIMMs should be installed with largest rank count to smallest. For example, if DR DIMMs are mixed with SR DIMMs, DR DIMMs should be placed in the lowest DIMM slots, followed by the SR DIMMs.

For more information on memory configuration, see the *Dell PowerEdge R320 Systems Owner's Manual* on Dell.com/Support/Manuals.

Memory speed

The R320 supports memory speeds of up to 1600MT/s, depending on the DIMM types installed and the configuration. The loading within a channel significantly affects memory speed.



Table 9 illustrates the maximum achievable speed of the Intel Xeon processor E5-2400 and E5-2400 v2 product families based on memory loads.

- Green boxes are defaults for performance per watt
- White boxes (with lower voltage) can save power but will run at slower speeds
- White boxes (with higher voltage) can be custom configured in the bios

Table 9. Memory speed capabilities

DIMM type	DIMM rank	DIMM-rated voltage and speed	Intel Xeon processor E5-2400 and E5-2400 v2 product families DIMMs per channel (DPC)			
			1 DPC		2 DPC	
			1.35V	1.5V	1.35V	1.5V
RDIMM	1R/2R	DDR3L (1.5V) 1600MT/s	1600	1600	1600	1600
RDIMM	1R/2R	DDR3L (1.35V/1.5V) 1333MT/s	1333	1333	1333	1333
UDIMM	1R/2R	DDR3L (1.35V/1.5V) 1600MT/s	1600	1600	1600	1600
RDIMM	4R	DDR3L (1.35V/1.5V) 1333MT/s	1066	1333	1066	1066
LRDIMM	4R	DDR3L (1.35V/1.5V) 1333MT/s				

Memory RAS features

RAS features help keep the system online and operational without significant impact to performance, and can decrease data loss and crashing due to errors. RAS aids in rapid, accurate diagnosis of faults that require service. Table 10 describes the RAS features supported on the R320.

Table 10. Memory RAS features

Feature	Description
Dense configuration optimized profile	Increased memory reliability can be a result from this selectable platform profile that adjusts parameters to reduce faults regarding refresh rates, speed, temperature and voltage.
Memory demand and patrol scrubbing	Demand scrubbing is the ability to write corrected data back to the memory once a correctable error is detected on a read transaction. Patrol scrubbing proactively searches the system memory, repairing correctable errors.



Feature	Description
Recovery from single DRAM device failure	Recovery from Single DRAM Device Failure (SDDC) provides error checking and correction that protects against any single memory chip failure as well as multi-bit errors from any portion of a single memory chip.
Failed DIMM isolation	This feature provides the ability to identify a specific failing DIMM channel pair, thereby enabling the user to replace only the failed DIMM pair.
Memory mirroring: intra-socket	Memory mirroring is a method of keeping a duplicate (secondary or mirrored) copy of the contents of memory as a redundant backup for use if the primary memory fails. The mirrored copy of the memory is stored in memory of the same processor socket.
Memory address parity protection	This feature provides the ability to detect transient errors on the address lines of the DDR channel.
Memory sparing (rank)	Memory sparing allocates one rank per channel as a spare. If excessive correctable errors occur in a rank or channel, it is moved to the spare area while the operating system is running to prevent the error from causing an uncorrectable failure.
Memory thermal throttling	This feature helps to optimize power/performance and can also be used to prevent DIMMs from overheating.

For information on memory mirroring and sparing configurations, see the *Dell PowerEdge R320 Systems Owner's Manual* on Dell.com/Support/Manuals.



6 Storage

The Dell PowerEdge R320 supports internal and external storage options and controllers, different drive types and different chassis configurations for a varied number of drives.

Internal storage

R320 has three chassis to support up to three different drive-bay options.

- Eight 3.5-inch drive options (base configuration, cabled tray)
- Four 3.5-inch drive options (volume configuration, hot-plug tray; 2.5-inch hybrid kit available for 2.5-inch drives)
- Eight 2.5-inch drive options (maximum drive support in 1U, hot-plug tray)

Supported hard drives

The R320 supports up to eight 2.5-inch or four 3.5-inch hard drives or solid-state drives. Self-encrypting drives (SEDs) are available. Table 11 lists more information about these drives. For an up-to-date list of supported hard drives for the R320, see Dell.com/PowerEdge.

Table 11. Supported hard drives

Form factor	Type	Speed (rpm)	Capacities
2.5"	Nearline SAS*	N/A	500G, 1TB, 1TB SED
	SAS	10K	300GB, 600GB, 900GB, 900GB SED, 1.2TB
	SAS	15K	146GB, 300GB, 300GB SED
	SAS SSD	N/A	200GB, 400GB
	SATA SSD	N/A	100GB, 160GB, 200GB, 300GB, 400GB, 600GB, 800GB
	SATA*	N/A	250GB, 500GB, 1TB
3.5"	SATA	7.2K	500GB, 1TB, 2TB, 3TB, 4TB
	Nearline SAS	7.2K	1TB, 2TB, 3TB, 4TB
	SAS	15K	300GB, 600GB

* Applies to the 8-drive bay only.

External storage

External storage for the R320 is available through optional HBAs for SAS and iSCSI. For more information, see Dell.com/Storage.



Storage controllers

Dell provides highly capable RAID options for you to ensure that your data remains safe. Dell's RAID controller options offer impressive performance improvements, including the following features:

- FastPath™ I/O: This feature can help accelerate performance when operating on SSDs.
- Split mirror: This function allows you to break mirrored disk connection in order to quickly replace a drive.
- Physical disk power management (Dimmer Switch™): This feature allows for power control of spare or idle drives, which can save energy and operating expenses.

Supported RAID controllers

The newest line of PERC (PowerEdge RAID Controller) cards offers high I/O performance for database applications and streaming digital media environments. The internal RAID controllers have a dedicated connection to the system board. The R320 supports the new PERC 8 family of controllers with improved functionality and faster performance.

The default PERC for the R320 is a mini-type PERC. The R320 also supports the new software RAID solution that supports RAID 0, 1, 5 and 10. The R320 supports the PERC cards listed in Table 12. For more information about the latest PERC offerings, see Dell.com/PERC.

Table 12. Supported RAID controllers

Controller	Description	Features	RAID modes supported	Form factor	Usage model
PERC H810 External	8-port, external and 6Gb/s PCIe RAID controller	Includes 1GB NV DDR3 cache, premium performance and feature set, security SED/EKMS, and SSD as cache	0, 1, 10, 5, 50, 6, 60	Adapter	Premium performance
PERC H710 Internal	8-port, internal 6Gb/s PCIe RAID controller	Includes 512MB NV DDR3 cache, advanced feature set, security SED/EKMS	0, 1, 10, 5, 50, 6, 60	Integrated mini-type	Performance
PERC H310 Internal	8-port, internal 6Gb/s PCIe RAID	Supports hot-plug drives, expansion, pass-through	0, 1, 10, 5, 50	Integrated mini-type	Value
PERC S110 Software RAID	3Gb/s SATA software RAID controller that supports up to 4 physical disks or 8 virtual disks	Supports up to four hot-plug SATA drives, no expansion, Microsoft Windows only	0, 1, 5, 10	System board-embedded SATA	Entry-level



Table 13 lists the storage matrix for the R320 hard drives, backplanes and Dell PERC cards.

Table 13. Hard-drive backplane options

Backplane options	Controller	Drive types
4 x 3.5" cabled chassis	PERC S110, H310 ¹ , H710 ¹	3.5" SATA 3.5" Nearline SAS 3.5" SAS
4 x 3.5" or 2.5" hot-plug	PERC S110, H310 ¹ , H710 ¹	3.5" SATA 3.5" Nearline SAS 3.5" SAS 2.5" SAS 2.5" SSD
8 x 2.5" hot-plug	PERC H310 ¹ , H710 ¹	2.5" SATA 2.5" Nearline SAS 2.5" SAS 2.5" SSD

¹Mini-type PERC

Optical drive

The R320 supports one slim, 9.5mm, internal optical drive on the 8-drive bay chassis through the system board embedded SATA. The 4-drive bay chassis supports the 12.7mm optical drive. The R320 supports both DVD-ROM and DVD+/-RW.

Tape drive

The R320 does not support internal tape drives.



7 Networking and PCIe

The Dell PowerEdge R320 offers balanced, scalable I/O capabilities, including integrated PCIe 3.0 capable expansion slots. The R320 supports up to two PCIe slots.

Embedded NIC controller

The R320 system board has one embedded NIC controller. The Broadcom 5720 Gigabit NIC chip is connected to the platform controller hub through a PCIe 2.0 x2 link.

The Broadcom 5720 is a 14th generation 10/100/1000Base-T Ethernet LAN controller solution suitable for high-performance server applications. The Broadcom 5720 combines dual triple-speed IEEE 802.3 compliant Media Access Controllers (MACs) with dual 10/100/1000 Ethernet transceivers (PHYs), selectable individually per port, a network controller-sideband interface (NC-SI), and an on-chip memory buffer in a single device. The device provides a PCIe 2.1-compliant interface, which operates at 5GT/s or 2.5GT/s x2 link width.

PCIe expansion

The R320 provides expanded PCIe slot capability over the previous servers. This is made possible by the 40 PCIe lanes available from each processor in the system. Dell designed the R320 to be PCIe 3.0-compliant in order to take full advantage of the processor capabilities.

PCIe slots

PCIe connectivity is integrated with the processor and chipset. Table 14 lists the slot configurations for the R320.

Table 14. PCIe slot configurations

One processor	
PCIe slot 1	PCIe x8 connector with x4 bandwidth; half-length, half-height, 2.0
PCIe slot 2	PCIe x16 connector with x16 bandwidth; half-length, full-height, 3.0
Storage slot	Storage slot for PERCs H310 or H710

PCIe expansion cards

The R320 supports a variety of PCIe expansion cards. Table 15 lists the supported add-in NICs and HBAs for the R320.

Table 15. Supported NICs and HBAs

Type	Adapter
1Gb/10Gb NICs	Broadcom 5720 2x1Gb Base-T
	Broadcom 5719 4x1Gb Base-T
	Intel I350 2x1Gb Base-T
	Intel I350 4x1Gb Base-T



Type	Adapter
1Gb/10Gb NICs	Broadcom 57810S 2x10Gb SFP+
	Broadcom 57810S 2x10Gb Base-T
	Intel X520 2x10Gb SFP+
	Intel X540 2x10Gb Base-T
	QLogic® QLE8262 2x10Gb SFP+
	Brocade® BR1020 2x10Gb SFP+
FC4/FC8 HBAs	QLogic QLE2460 4Gb
	QLogic QLE2462 4Gb
	QLogic QLE2560 8Gb
	QLogic QLE2562 8Gb
	Emulex LPe12000 8Gb
	Emulex LPe12002 8Gb
	Brocade BR815 8Gb
	Brocade BR825 8Gb

For the latest information on all supported add-in PCIe expansion cards for the R320, visit Dell.com/PowerEdge.



8 Power, thermal and acoustics

Lower overall system-level power draw is a result of breakthrough system design. The Dell PowerEdge R320 server maximizes performance per watt through a combination of power and cooling, energy-efficient technologies, and tools. Additionally, the PowerEdge R320 has an extensive collection of sensors that automatically track thermal activity, which helps regulate temperature thereby reducing server noise and power consumption.

Power consumption and energy efficiency

With the rise in the cost of energy coupled with increasing data center density, Dell provides tools and technologies to help you realize greater performance with less energy cost and waste. More efficient data center usage can reduce costs by slowing the need for additional center space. Table 16 lists the tools and technologies Dell offers to help you achieve your data center goals by lowering power consumption and increasing energy efficiency.

Table 16. Power tools and technologies

Feature	Description
Power supply unit (PSU) portfolio (hot-plug PSU only)	Dell's PSU portfolio includes intelligent features such as dynamically optimizing efficiency while maintaining availability and redundancy. Find additional information in the Power supply units section.
Tools for right-sizing	Dell Energy Smart Solution Advisor (ESSA) is a tool that helps you determine the most efficient configuration possible. With ESSA, you can calculate the power consumption of your hardware, power infrastructure and storage. ESSA can help you determine exactly how much power your server will use at a given workload, and the PSU Advisor can help you choose the best, most efficient PSU for your workload. Learn more at Dell.com/ESSA .
Industry compliance	Dell PowerEdge servers are compliant with relevant industry certifications and guidelines, including 80 PLUS. Additionally, the Dell PowerEdge R320 server has earned the ENERGY STAR® 1.0 Server designation.
Power monitoring accuracy (hot-plug PSU only)	PSU power monitoring improvements include: <ul style="list-style-type: none"> • Dell's power monitoring accuracy is currently 1%, whereas the industry standard is 5% • More accurate reporting of power • Better performance under a power cap
Power capping (hot-plug PSU only)	Use Dell's systems management to set the power cap limit for your systems to limit the output of a PSU and reduce system power consumption. Dell is the first hardware vendor to leverage Intel Node Manager for circuit-breaker fast capping.
Systems management (hot-plug PSU only)	iDRAC7 Enterprise provides server-level management that monitors, reports, and controls power consumption at the processor, memory and system level. Dell OpenManage Power Center delivers group power management at the rack, row and data center level for servers, power distribution units and uninterruptible power supplies.



Feature	Description
Active power management (hot-plug PSU only)	<p>Intel Node Manager: Dell offers a complete power management solution comprised of Intel Node Manager accessed through Dell iDRAC7 Enterprise and OpenManage Power Center that allows policy-based management of power and thermals at the individual server, rack, and data center level. Intel Node Manager is an embedded technology that provides individual server-level power reporting and power limiting functionality.</p> <p>Hot spare reduces power consumption of redundant power supplies.</p> <p>Thermal control of fan speed optimizes the thermal settings for your environment to reduce fan consumption and lower system power consumption.</p> <p>Idle power enables Dell servers to run as efficiently when idle as when at full workload.</p>
Dell Fresh Air cooling (Dual PSUs required)	<p>With the thermal design and reliability of Dell products, certain configurations have the capability to operate at excursion-based temperatures beyond the industry standard of 35°C (95°F) up to 45°C (113°F) for excursionary periods of time and up to a 26°C dew point at 90% relative humidity; without impacting your availability model. Find additional information at Dell.com/FreshAir.</p>
Rack infrastructure	<p>Dell offers some of the industry's highest-efficiency power infrastructure solutions, including:</p> <ul style="list-style-type: none"> • Power distribution units • Uninterruptible power supplies • Energy Smart containment rack enclosures <p>Find additional information at content.dell.com/us/en/enterprise/power-and-cooling-technologies-components-rack-infrastructure.aspx.</p>

Find additional information at Dell.com/PowerAndCooling.

Power supply units

Energy Smart power supplies (hot-plug PSUs only) have intelligent features, such as the ability to dynamically optimize efficiency while maintaining availability and redundancy. Also featured are enhanced power-consumption reduction technologies, such as high-efficiency power conversion and advanced thermal-management techniques and embedded power-management features, including high-accuracy power monitoring.

The R320 power supply subsystem consists of one non-redundant or up to two hot-plug AC-DC power supplies. The power supply provides +3.3V/5V/12V and +12Vaux for non-redundant design and provides 12V and 12Vaux for redundant design. There are several voltage regulators in the system to supply different voltage levels needed by different logic devices. The redundant power supplies are managed through a PMBus interface.

The following power supply options are available for the R320:

- 350W AC, cabled, non-redundant
- 350W AC, hot-plug redundant
- 550W AC, hot-plug redundant



Figure 7 shows a 350W power supply unit extended from the R320 chassis.

Figure 7. 350W power supply unit



The PowerEdge R320 supports up to two AC with 1+1 redundancy, auto-sensing and auto-switching capability.

To support Intel turbo boost feature (default enabled in BIOS), system with 95W processors (8-core or 6-core) and 350W cabled PSU may not be sufficient to support feature rich configurations. For feature rich configurations, using a 350W or 550W hot-plug PSU is recommended in addition to verifying energy efficiency configurations using the Dell Energy Smart Solution Advisor at Dell.com/ESSA.

Dell PSUs have achieved Platinum efficiency levels as shown in Table 17.

Table 17. Power supply efficiency

Form factor	Output	Class	Efficiency targets by load			
			10%	20%	50%	100%
Redundant	350W AC	Platinum	82.0%	90.0%	94.0%	91.0%
	550W AC	Platinum	82.0%	90.0%	94.0%	91.0%
Non-redundant	350W AC	Bronze	N/A	85.0%	85.0%	85.0%

Find power supply and additional environmental specifications for the R320 in **Appendix A**.

Thermal and acoustics

Optimized thermal management makes the PowerEdge R320 cool and quiet. Benefiting from smart cooling fan speed control, the R320 can keep both high performance and good acoustics across a wide range of ambient temperatures from 10°C to 35°C (50°F to 95°F) and to extended ambient temperature ranges (see Table 26). Operating environments for the R320 can vary from the data center to general-use spaces. In a typical configuration, the R320 is suitable for an open office environment.

Thermal design

The thermal design of the PowerEdge R320 reflects the following:

- **Multiple sensors are monitored for thermal feedback control:** The PowerEdge R320 dynamically controls system cooling fan speed based on responses from component temperature sensors, including processors, HDDs, DIMMs, storage cards and the inlet ambient



temperature. Thermal control detects and responds to hardware configuration. Thermal management adjusts cooling according to what the system really needs, and draws lower fan power draw and generates lower acoustical noise levels than servers without such controls.

- **User-configurable settings:** An R320 thermal control design target is to minimize the contribution of fan power to overall system power. However, with the understanding and realization that every customer has a unique set of circumstances or expectations of the system, in this generation of servers, we are introducing limited user-configurable settings in the iDRAC7 BIOS setup screen. For more information, see the *Dell PowerEdge R320 Systems Owner's Manual* on Dell.com/Support/Manuals and "Advanced Thermal Control: Optimizing across Environments and Power Goals" on Dell.com/PowerEdge.
- **Fan fault tolerance:** The R320 allows continuous operation with a motor failure in the system. The base configuration of the R320 has four fans. An additional fan is needed when using redundant power supplies. The fault tolerance feature allows one motor fan to fail at a time allowing a fan replacement within 360 hours of a fan failure.
- **Environmental specifications:** The optimized thermal management makes the R320 reliable under a wide range of operating environments as shown in the environmental specifications in Table 26. Many configurations are also compliant under expanded operating temperature environments, but a few are not.

Acoustical design

The acoustical design of the PowerEdge R320 reflects the following:

- **Versatility:** The PowerEdge R320 saves you power draw in the data center, but is quiet enough for the office environment in typical and minimum configurations. Compare the values for LpA in Table 18 for these configurations, and note that they are lower than ambient measurements of typical office environments.
- **Adherence to Dell's high sound quality standards:** Sound quality is different from sound power level and sound pressure level in that it describes how humans respond to annoyances in sound, like whistles and hums. One of the sound quality metrics in the Dell specification is prominence ratio of a tone, which is listed in Table 18.
- **Noise ramp and descent during bootup from power off:** Fan speeds and noise levels ramp during the boot process (from power off to power on) in order to add a layer of protection for component cooling in the case that the system were not to boot properly. To keep bootup as quiet as possible, the fan speed reached during bootup is limited to about half of full speed.
- **Noise level dependencies:** If acoustics is important to you, you may want to make the following configuration choices and settings for the PowerEdge R320 for quieter operation:
 - In the BIOS, select the power-optimized DAPC rather than performance-optimized for the system thermal profile
 - Turn hot spare feature off in PSU
 - Since hard drive noise is highly dependent on spindle speed, the 7200-rpm SATA hard drive will have the quietest hard drive operation

However, some components cause significant but not necessarily intuitive increases in loudness when they are installed in the R320. Contributors to acoustical output can include:

- PERC H710 mini or PERC H810



Table 18 details the acoustical performance for the R320.

Table 18. Acoustical performance

Configuration (23 ± 2°C ambient)	CPU	Hard drives	Power supply unit	Memory	PCI card/HDD controller	Operating mode	L _{WA} -UL ¹ (bels)	L _{pA} ² (dBA)	Prominent tones ³
Typical x4 hot-plug HDD chassis	1 (80W)	3 x 3.5" 300GB SATA (7.2K)	2 x 350W	4 x 4GB 1333Hz	1 x Broadcom Dual Port 1GbE	Idle ⁴	4.8	28	None
					1 x PERC H310 mini	Stress ⁵	5.1	30	None
Feature rich x8 hot-plug HDD chassis	1 (95W)	6 x 2.5" 300GB SAS (10K)	2 x 350W	6 x 8GB 1600Hz	1 x Intel Quad Port 10GbE	Idle ⁴	4.8	29	None
					1 x PERC H710 mini	Stress ⁵	5.1	30	None

¹L_{WA}-UL is the upper limit sound power levels (L_{WA}) calculated per section 4.4.1 of ISO 9296 (1988) and measured in accordance to ISO 7779 (2010).

²L_{pA} is A-weighted sound pressure level at front bystander position calculated per section 4.3 of ISO 9296 (1988) and measured in accordance with ISO 7779 (2010) Section 8.6.2. The system is placed inside rack in 75 cm height.

³Prominent tone: Criteria of D.6 and D.11 of ECMA-74 11th ed. (2010) are followed to determine if discrete tones are prominent. The system is placed inside rack in 75 cm height and acoustic transducer, binaural head, is at front bystander position; reference ISO 7779 (2010) Section 8.6.2.

⁴Idle: Reference ISO 7779 (2010) definition 3.1.7; system is running in its operating system but no other specific activity.

⁵Stress: An operating mode per ISO 7779 (2010) definition 3.1.6. The software SPECPower at 50% is activated to stress the processors and DIMM.

For more information on Dell's acoustical design, see the [Dell Enterprise Acoustics](#) white paper.



9 Rack rails and cable management

The sliding and static rail systems for the Dell PowerEdge R320 provide tool-less support for four-post racks with square or unthreaded round mounting holes. Both rail systems also support tooled mounting in four-post threaded racks, and the static rails support tooled mounting in two-post (Telco) racks as well for added versatility.

Compared to the R310 sliding rails that required the use of adapter brackets, the sliding rails for the R320 now offer support for threaded hole racks with the ReadyRails II mounting interface. The optional cable management arm (CMA) can be mounted on either the left or right side of the sliding rails without the use of tools for fast and easy deployment.

Sliding and static rail systems

The R320 supports both sliding rails and static rails. Both rails have a new slim rail design that supports the wide system chassis. The rails ship in the tool-less mounting configuration, but can be converted to the tooled configuration quickly and easily.

Sliding rails include a self-adjusting feature to allow the rails to be shared across multiple systems and accommodate various chassis depths. The sliding rail system allows you to fully extend the server out the rack for easy access for service. The sliding rails are available with or without the optional CMA. Figure 8 shows the sliding rails with the CMA.

Figure 8. Sliding rails with optional CMA

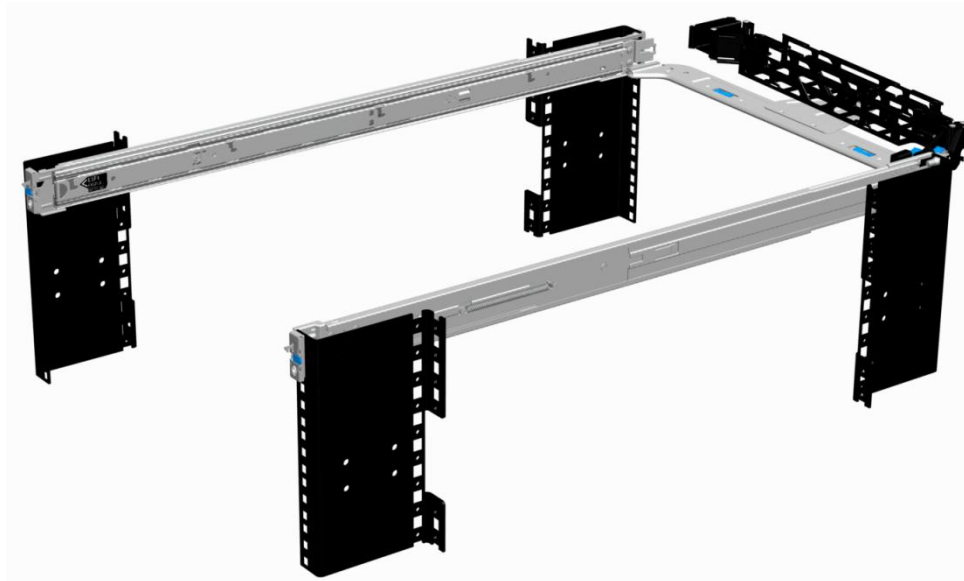

The static rails (shown in Figure 9) support a wider variety of racks than the sliding rails but do not support serviceability in the rack and are not compatible with the CMA.

Figure 9. Static rails

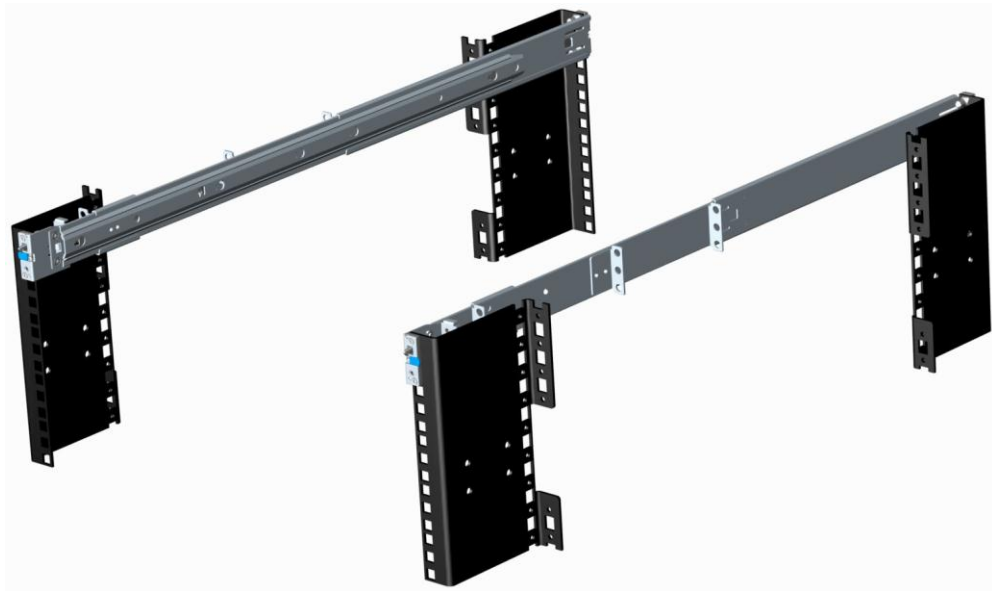

One key factor in selecting the proper rails is identifying the type of rack in which they will be installed. Both the sliding rails and the static rails support tool-less mounting in 19"-wide, EIA-310-E compliant square hole and unthreaded round hole four-post racks. Both also support tooled mounting in threaded hole four-post racks, but only the static rails, as the more universal solution, support mounting in two-post (Telco) racks.

Table 19 lists the rack types that the R320 supports. The R320 is backward compatible with the R310 rails and CMA.

Table 19. Supported rack types

Product	Rail identifier	Mounting interface	Rail type	Rack types supported				
				4-post			2-post	
				Square	Round	Thread	Flush	Center
R320	A7	ReadyRails II	Sliding	✓	✓	✓	X	X
	A8	ReadyRails	Static	✓	✓	✓	✓	✓

Other key factors governing proper rail selection include the spacing between the front and rear mounting flanges of the rack, the type and location of any equipment mounted in the back of the rack such as power distribution units (PDUs), and the overall depth of the rack. Due to their reduced complexity and lack of need for CMA support, the static rails offer a greater adjustability range and a smaller overall mounting footprint than the sliding rails.

For detailed information about static and sliding rails, see the Rack rail specifications section in Appendix A. For more information on installing the R320 in a rack, see the *Rack Installation Instructions* on Dell.com/Support/Manuals.



Cable management arm

The optional CMA organizes and secures the cords and cables exiting the back of the server and unfolds to allow the server to extend out of the rack without having to detach the cables. Some key features of the R320 CMA include:

- Large U-shaped baskets to support dense cable loads
- Open vent pattern for optimal airflow
- Ability to be mounted on either side
- Use of hook-and-loop straps rather than plastic tie wraps to eliminate the risk of cable damage during cycling
- Low-profile fixed tray to both support and retain the CMA in its fully closed position
- Ability to mount the CMA and tray without the use of tools, due to snap-in designs



10 Operating systems and virtualization

The Dell PowerEdge R320 supports a wide range of industry-standard operating systems and virtualization software.

Supported operating systems

Table 20 lists the primary operating systems supported on the R320. For the latest information on supported operating systems, see Dell.com/OSsupport.

Table 20. Primary operating system support

Operating system	Platform	Edition
Red Hat Enterprise Linux 5.8 ¹	x32, x64	N/A
Red Hat Enterprise Linux 6.3 ²	x64	N/A
SUSE Linux Enterprise Server 11 SP2	x64	N/A
SUSE Linux Enterprise Server 11 SP3	x64	N/A
SUSE Linux Enterprise Server 10 SP4	x64	N/A
Microsoft Windows Server 2012 R2	x64	N/A
Microsoft Windows Server 2012	X64	Essentials Standard
Microsoft Windows Small Business Server 2011	x64	Standard Premium add-on
Microsoft Windows Server 2008 R2 with SP1	x64 (with Hyper-V role enabled)	Web Standard Enterprise Data center

¹RHEL 5.7 is the minimum supported version. Current drop in box option is RHEL 5.8.

²RHEL 6.1 is the minimum supported version. Current factory install is RHEL 6.3.



Supported virtualization

One of the key features for virtualization on the PowerEdge R320 is the support for a fail-safe hypervisor. By running a hypervisor on an optional SD card and installing a backup copy on the other mirrored SD card, you can protect against hardware failure and maximize virtualization uptime.

Table 21 highlights the virtualization support for the R320.

Table 21. Virtualization support

Operating systems	Install version	Factory options	Internal dual SD module install support	
VMware	vSphere v5.0	ESXi	DIB	Yes
	vSphere v5.1 U1	ESXi (one version)	FI/DIB	Yes
	vSphere v5.1	ESXi (one version)	DIB	Yes
	vSphere v5.5	ESXi (one version)	DIB	Yes
Citrix	XenServer 6.1	N/A	DIB	No
Red Hat²	Enterprise Virtualization v3.1	N/A	DIB	No

FI = factory install; DIB = drop in box

²No OpenManage support; drop in box license registration card only.



11 Dell OpenManage systems management

Whether your IT environment consists of a few servers or a few thousand servers, Dell OpenManage systems management solutions provide comprehensive management for evolving IT environments. OpenManage is based on open standards and provides agent-based and agent-free server lifecycle management functionality for Dell PowerEdge servers. OpenManage solutions help you automate and streamline essential hardware management tasks.

The advanced management capabilities of Dell OpenManage also integrates into offerings from other popular systems management solutions that you may already use, making Dell platforms easy to manage and deploy in any IT environment. This ensures your IT services are available when your business needs them. If you have already standardized on offerings from industry leaders, such as BMC Software, Microsoft, Symantec™, VMware, or other vendors, you can leverage OpenManage integration and connections developed to use with your existing systems management framework to efficiently manage Dell servers, storage, business-client PCs and network devices.

Start with a firm foundation for efficient hardware management using OpenManage tools and utilities. OpenManage systems management solutions consist of a combination of embedded management features and software products that help you automate and simplify the entire server lifecycle: deploy, update, monitor and maintain. OpenManage solutions are innovatively designed for simplicity and ease of use to help you reduce complexity, save time, achieve efficiency, control costs and empower productivity.

Systems management solutions

Dell systems management solutions include a wide variety of tools, products and services that enable you to leverage an existing systems management framework. As shown in Figure 10, Dell systems management solutions are centered on OpenManage server management, featuring iDRAC7 with Lifecycle Controller.

Figure 10. Dell systems management solutions



OpenManage systems management

The Dell OpenManage systems management portfolio includes powerful hardware and software management tools and utilities. OpenManage simplifies the lifecycle of deploying, updating, monitoring and maintaining Dell PowerEdge servers.

iDRAC7 with Lifecycle Controller

The Integrated Dell Remote Access Controller 7 (iDRAC7) with Lifecycle Controller is the heart of the second generation of Dell PowerEdge server embedded management functionality. In addition to enabling agent-free management, iDRAC7 with Lifecycle Controller provides remote access to the system — whether or not there is a functioning operating system running on the server. These embedded features improve all aspects of a typical server lifecycle. Table 22 describes the functions and benefits of iDRAC7 with Lifecycle Controller.

Table 22. iDRAC7 with Lifecycle Controller functions and benefits

Feature	Function	Benefit
Out of band (OOB)	iDRAC7 offers real-time OOB discovery, inventory, deployment monitoring, alerting and updates for servers and internal storage	Manage servers independent of the OS type or status — even if an OS is not installed
Single code base	All server types have the same embedded management hardware and firmware	Simplified and consistent maintenance across server platforms
Dedicated GigE port (PowerEdge rack and tower systems)	GbE replaces 10/100 on predecessor iDRAC6	Fast throughput for better performance, compatibility with setup for switches
Email alerts	Simplified, informative, and actionable messaging including key information on systems and components, warranty, and service tag	More detail allows IT administrators to be more efficient in diagnosing and remediating an issue; alerts include a direct, embedded URL in the email notification to further speed resolution
vFlash media	Enabled with iDRAC7 Enterprise	Allows for use of a non-Dell SD card
Enhanced power management	Integration with Intel Node Manager provides data center level power monitoring and capping (requires iDRAC7 Enterprise)	Fine tune data center power policies, capping, and usage; report on historical power usage by rack, row or room using Power Center Manager (new)



Feature	Function	Benefit
Electronic licensing	Upgrades to iDRAC7 Express or iDRAC7 Enterprise by software licensing key and license portal (may require installation of hardware option for 200–500 series servers)	<p>If iDRAC7 Express or iDRAC7 Enterprise is ordered during initial point of sale, license key is installed. If Basic Management is ordered during initial point of sale, customer must request a license key through the Dell Licensing Portal.</p> <p>For most server models, embedded server management and electronic licensing enables feature enhancements that do not require installation of additional hardware or system downtime.</p>

iDRAC7 feature comparison

The systems management default for the R320 is basic management with an upgrade option for iDRAC7 Express or iDRAC7 Enterprise. A detailed feature comparison of basic management, iDRAC7 Express, and iDRAC7 Enterprise is shown in Table 23.

Table 23. Feature comparison for Basic Management, iDRAC7 Express, and iDRAC7 Enterprise

Feature	Basic Management	iDRAC7 Express	iDRAC7 Enterprise
Local configuration with Lifecycle Controller GUI	•	•	•
IPMI 2.0	•	•	•
Embedded diagnostics	•	•	•
Local OS install	•	•	•
Local updates	•	•	•
Driver pack	•	•	•
Shared NIC (LOM) ¹	•	•	•
Remote update	• ²	•	•
Power control	• ²	•	•
Power monitoring		•	•
Encryption		•	•
IPv6		•	•
Auto-discovery		•	•
Auto-recovery		•	•
Web GUI		•	•
Remote CLI		•	•
Local/SSH CLI		•	•



Feature	Basic Management	iDRAC7 Express	iDRAC7 Enterprise
Serial redirection		•	•
Remote config		•	•
Email alerts		•	•
SNMP alerts		•	•
Comprehensive monitoring		•	•
Crash screen capture ³		•	•
Dedicated NIC 1Gbps (100MB in iDRAC6)			• ⁴
Part replacement			•
Backup and restore configurations			•
Virtual console (4 user)			•
Virtual console chat			•
Support for customer supplied SD cards for vFlash media			•
Virtual flash partitions			•
Virtual media			•
Virtual folders			•
Remote file share			•
Crash video playback			•
Boot record/playback			•
Power capping			•
Enterprise group power management			•
Directory services (AD, LDAP)			•
PK authentication			•
Two-factor authentication ⁴			•

¹Rack and tower systems only

²Feature available with IPMI, not web GUI

³Requires OMSA agent on target server

⁴Uses Microsoft ActiveX[®] on Internet Explorer[®] only

Agent-based systems management

Most systems management solutions require pieces of software, called agents, to be installed on each node in order to be managed within the IT environment. Additionally, the same agent is often used as a local interface into the hardware health and may be accessed remotely as a management interface, typically referred to as a one-to-one interface. For customers that continue to use agent-based solutions, Dell provides OpenManage Server Administrator.



OpenManage Server Administrator

The Dell OpenManage Server Administrator (OMSA) agent gives you a comprehensive, one-to-one systems management solution for both local and remote servers and their storage. OMSA can help simplify single-server monitoring with a secure command-line interface (CLI) or web-based management graphical user interface (GUI). It can also be used to view system configuration, inventory, health and performance.

Agent-free systems management

Because Dell PowerEdge 12th generation servers include the embedded server management feature, iDRAC7 with Lifecycle Controller, in many cases there is no need to install an OpenManage systems management software agent into the operating system of a Dell PowerEdge system. This greatly simplifies and streamlines the management footprint and performance of management tasks.

Dell OpenManage consoles

The central console in a systems management solution is often referred to as the one-to-many console. The central console provides a rapid view and insight into the overall health of all systems in the IT environment. The Dell systems management portfolio includes several powerful consoles, depending upon your needs, including the following:

- **Dell OpenManage Essentials:** OpenManage Essentials (OME) provides a comprehensive view of Dell systems, devices, and components in an enterprise network. It is used to discover, inventory and monitor Dell PowerEdge servers, Compellent, EqualLogic™ and PowerVault™ storage, Dell Networking and Dell Networking™ switches, and business client PCs; to update and configure Dell servers; and to create asset reports. OpenManage Essentials also communicates health status alerts for Dell servers, storage and network devices to the Dell KACE™ K1000 service desk and is available as a no-charge software download from Dell.com/Support.

OpenManage systems management tools and utilities

Dell OpenManage systems management tools and utilities consist of the following:

- **Dell Repository Manager:** The Dell Repository Manager (RM) is a standalone GUI-based productivity tool that helps simplify the process of managing downloads and baseline BIOS, firmware and driver updates. Repository Manager can create deployment disks as well as create and manage customized repositories.
- **Dell OpenManage Server Update Utility:** The Dell Server Update Utility (SUU) is a DVD-based application for identifying and applying BIOS and firmware updates to Dell PowerEdge servers.
- **Dell OpenManage Systems Build and Update Utility:** The Dell System Build and Update Utility (SBUU) provides one-to-one and one-to-many deployment and single-server update capabilities in the pre-operating system environment.
- **Dell Update Packages:** The Dell Update Packages (DUP) are self-contained executable in a standard package format that update a software element on Dell PowerEdge servers, such as the BIOS, drivers, firmware and other software updates.
- **Dell OpenManage Deployment Toolkit:** The Dell OpenManage Deployment Toolkit (DTK) is a CLI-based tool that includes a set of utilities for configuring and deploying Dell PowerEdge systems, and can be used to build scripted, unattended OS installations to deploy a large quantity of Dell servers in a reliable fashion.
- **RACADM:** The RACADM command-line utility provides a scriptable interface that allows local or remote configuration of iDRAC7 with Lifecycle Controller.



- **IPMITool:** The IPMITool includes scriptable console application programs used to control and manage remote systems using IPMI version 1.5 and later protocol versions.

OpenManage Integration with third-party consoles

Dell OpenManage integrates iDRAC with Lifecycle Controller functionality with several leading third-party consoles, including Microsoft System Center, VMware vCenter and BMC Software BladeLogic and ProactiveNet Performance Management.

Microsoft System Center offers management of applications, services, physical resources, hypervisors, software defined networks, configuration and automation in a single comprehensive platform. For customers with existing investments in MS System Center, Dell offers the OpenManage Integration Suite for Microsoft System Center, a portfolio of software tools that streamline and optimize the efficiency and effectiveness of managing Dell hardware with System Center.

Dell OpenManage Integration Suite for Microsoft System Center includes:

- **Dell Server Management Pack Suite for Microsoft System Center Operations Manager (SCOM):** This suite of Dell Server Management Packs enables several functions through System Center Operations Manager, including agent-free and agent-based in-band and out-of-band discovery and monitoring of PowerEdge racks, towers, blades and VRTX systems.
- **Dell Lifecycle Controller Integration (DLCI) for Microsoft System Center Configuration Manager (SCCM):** This tool provides Dell Lifecycle Controller Integration (DLCI), within SCCM to manage Dell PowerEdge servers agent-free, including auto-discovery, operating system deployment and configuration of hardware elements, (RAID, NIC, BIOS, iDRAC), OS and hypervisor agnostic updates, firmware management and system viewer utilities.
- **Dell Server Deployment Pack and Dell Hardware Update Catalogs:** Dell Server Deployment Pack automates bare-metal configuration and deployment of a variety of Microsoft Windows operating system and application versions from a central location to Dell PowerEdge servers across a network. Dell Server Update Catalogs scan and update BIOS, firmware and drivers for PowerEdge servers.
- **Dell Server PRO Management Pack with PRO-Tips for Microsoft System Center Virtual Machine Manager (SCVMM):** This pack integrates Dell PowerEdge server knowledge with Microsoft System Center 2012 Virtual Machine Manager (SCVMM) and Operations Manager (SCOM). Dell Server PRO Management Pack provides effective management of Dell physical servers that host virtual workloads running on Microsoft Windows Server Hyper-V by monitoring the health of the host system and enabling recommendations and remedial actions (PRO-Tips) when a compromised system is identified.
- **OpenManage Integration for VMware vCenter:** This plug-in allows IT administrators to monitor, provision, and manage the physical PowerEdge server hardware and firmware from a dedicated Dell menu accessed through the VMware vCenter console. IT Administrators use the same role-based, access-control model within vCenter to combine physical and virtual server management.
- **BMC Software:** BMC offers best-in-class integration of OpenManage iDRAC with Lifecycle Controller technology within select BMC Enterprise Systems Management (ESM) portfolio products.

OpenManage Connections with third-party consoles

Dell OpenManage Connections are designed specifically for monitoring Dell server and storage platforms within infrastructures managed by HP Operations Manager, IBM Tivoli Netcool/OMNIbus or Computer Associates (CA) Network and Systems Management (NSM). OpenManage Connections



improve operational efficiency and flexibility in managing Dell hardware in large heterogeneous data center environments.

- **Dell OpenManage Connection for Computer Associates Network and Systems Management:** This connection enables monitoring of PowerEdge servers and PowerVault storage arrays in environments managed by Computer Associates Network and Systems Management (CA NSM) with no installation of the CA agent required on the Dell hardware.
- **Dell OpenManage Connection for HP Operations Manager:** This connection enables several functions through HP Operations Manager, including auto-grouping, SNMP trap reception, global health monitoring, and a context-sensitive launch of OpenManage Server Administrator.
- **Dell OpenManage Connection for IBM Tivoli Netcool/OMNIBus:** This connection provides event monitoring capabilities to monitor Dell PowerEdge servers and Dell EqualLogic systems. It allows event monitoring, automatic event correlation and launching device consoles from the Netcool/OMNIBus console.

Dell server management operations

Dell OpenManage systems management automates the most essential hardware management tasks — deploy, update, monitor and maintain. Figure 11 illustrates systems management operations that are performed more efficiently, and with fewer tools, through utilization of the Dell PowerEdge embedded management feature iDRAC7 with Lifecycle Controller.

Figure 11. Systems management server lifecycle

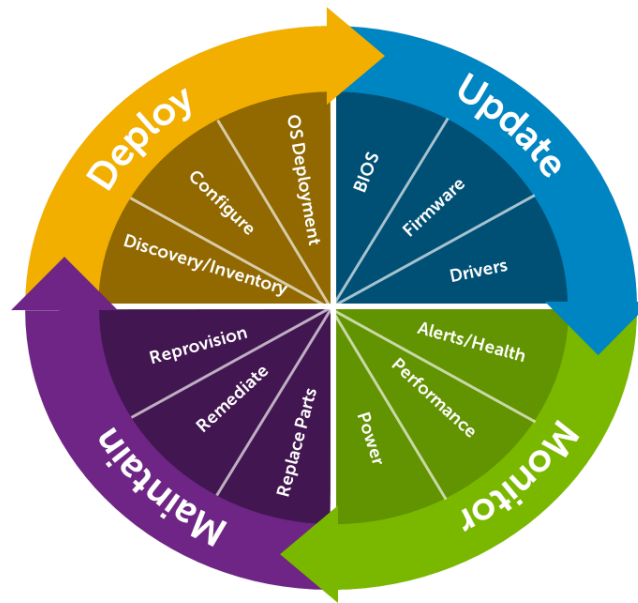

Table 24 lists the products that are available for one-to-one and one-to-many operations, and when they are used in the server’s lifecycle.



Table 24. One-to-one and one-to-many operations

Operation	One-to-one	One-to-many	
Deploy	<ul style="list-style-type: none"> • iDRAC7 with Lifecycle Controller GUI • DTK • SBUU 	<ul style="list-style-type: none"> • Symantec Deployment Server • OpenManage Integration for VMware vCenter • KACE K1000 Appliance • Lifecycle Controller Remote Services • BMC BladeLogic integration with Lifecycle Controller 	<ul style="list-style-type: none"> • Dell Server Deployment Pack (DSDP) for Microsoft System Center Configuration Manager and Dell Lifecycle Controller Integration (DLCI) for Microsoft System Center Configuration Manager
Update	<ul style="list-style-type: none"> • iDRAC7 with LifeCycle Controller • Repository Manager • DUP • SUU • SBUU • OpenManage Integration for VMware vCenter 	<ul style="list-style-type: none"> • Dell OpenManage Essentials • Lifecycle Controller Remote Services 	<ul style="list-style-type: none"> • Dell Update Catalogs for Microsoft System Center Configuration Manager • Dell Lifecycle Controller Integration (DLCI) for Microsoft System Center Configuration Manager
Monitor	<ul style="list-style-type: none"> • iDRAC7 with Lifecycle Controller • OMSA 	<ul style="list-style-type: none"> • Dell OpenManage Essentials • BMC ProactiveNet Performance Management integration with Lifecycle Controller • Dell OpenManage Power Center 	<ul style="list-style-type: none"> • OpenManage Integration for VMware vCenter • BMC ProactiveNet Performance Management integration with Lifecycle Controller • Dell Server Management Pack Suite for Microsoft System Center
Maintain	<ul style="list-style-type: none"> • IPMI • iDRAC7 with Lifecycle Controller GUI 	<ul style="list-style-type: none"> • Lifecycle Controller Remote Services 	<p>Remediate:</p> <ul style="list-style-type: none"> • Dell Server PRO Management Pack for Microsoft System Center Virtual Machine Manager (SCVMM) <p>Replace parts:</p> <ul style="list-style-type: none"> • Dell Lifecycle Controller Integration (DLCI) for Microsoft System Center Configuration Manager

For additional detailed information on Dell's systems management portfolio, see the *Dell OpenManage Systems Management Overview Guide* on Dell.com/Support/Manuals.



Appendix A. Additional specifications

Chassis dimensions and weight

Figure 12 details the dimensions of the Dell PowerEdge R320 chassis.

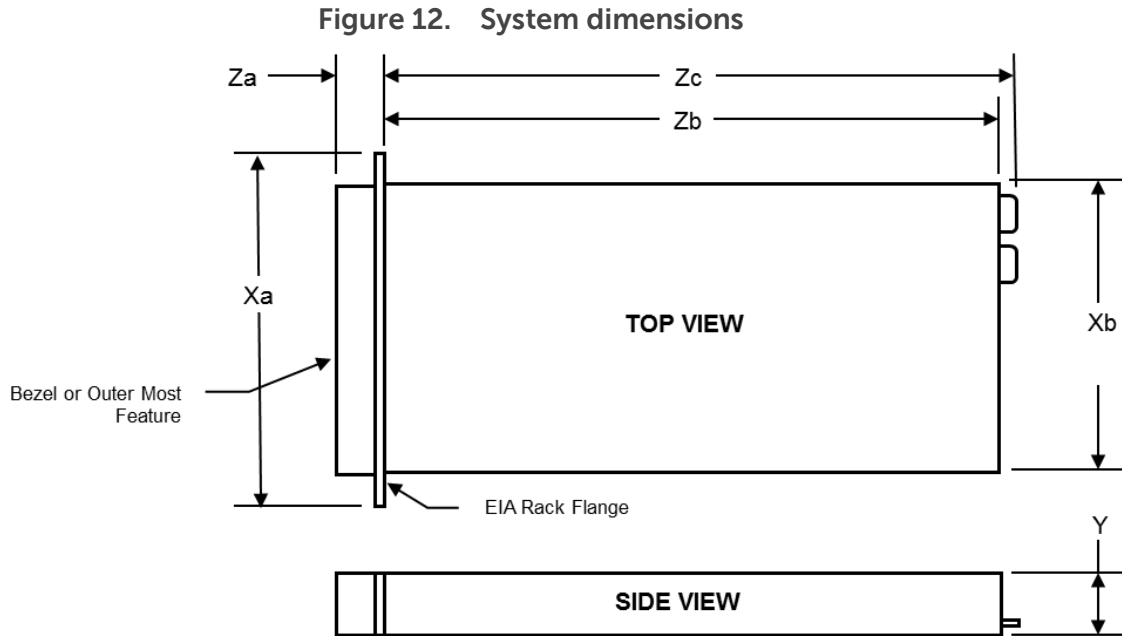

Xa	Xb	Y	Za with bezel	Za without bezel	Zb ¹	Zc
482.4mm	434.0mm	42.8mm	35.0mm	21.0mm	607.0mm	625.2mm with cabled PSU 642.3mm with redundant PSU

¹Zb goes to the nominal back wall external surface where the system board I/O connectors are located.

The R320 chassis at maximum configuration is 19.3 kg (42.55 lb).

Video specifications

The Dell PowerEdge R320 iDRAC incorporates an integrated video subsystem. The graphics controller is the 2D Matrox® G200. The video frame buffer (16MB) is contained within the iDRAC RAM (256MB) device.

The R320 system supports the 2D graphics video modes listed in Table 25.

Table 25. Supported video modes

Resolution	Refresh rate (Hz)	Color depth (bit)
640 x 480	60, 70	8, 16, 32
800 x 600	60, 75, 85	8, 16, 32
1024 x 768	60, 75, 85	8, 16, 32
1152 x 864	60, 75, 85	8, 16, 32



Resolution	Refresh rate (Hz)	Color depth (bit)
1280 x 1024	60, 75	8, 16, 32

Environmental specifications

Table 26 details the environmental specifications for the R320. For additional information about environmental measurements for specific system configurations, see Dell.com/environmental_datasheets.

Table 26. Environmental specifications

Fresh Air: temperature, humidity, altitude de-rating	
Continuous operation	10°C to 35°C (50°F to 95°F) at 10% to 80% relative humidity with 26°C (78.8°F) maximum dew point (maximum wet bulb temperature). De-rate maximum allowable dry bulb temperature at 1°C per 300m above 950m (1°F per 547 ft above 3117 ft).
Expanded operation	<p>When operating in the expanded temperature range, system performance may be impacted, and ambient temperature warnings may be reported on the LCD and in the System Event Log.</p> <p>≤ 10% of annual operating hours: 5°C to 10°C and 35°C to 40°C (with no direct sunlight on the equipment) at 5% to 85% relative humidity with 26°C dew point (maximum wet bulb temperature). Outside the standard operating temperature (10°C to 35°C), the system can operate down to 5°C or up to 40°C for a maximum of 10% of its annual operating hours. For temperatures between 35°C and 40°C (95°F to 104°F), de-rate maximum allowable dry bulb temperature by 1°C per 175m above 950m (1°F per 319 ft above 3117 ft).</p> <p>≤ 1% of annual operating hours: -5°C to 5°C and 40°C to 45°C (with no direct sunlight on the equipment) at 5% to 90% relative humidity with 26°C dew point (maximum wet bulb temperature). Outside the standard operating temperature (10°C to 35°C), the system can operate down to -5°C or up to 45°C for a maximum of 1% of its annual operating hours. For temperatures between 40°C and 45°C (104°F to 113°F), de-rate maximum allowable dry bulb temperature by 1°C per 125m above 950m (1°F per 228 ft above 3117 ft).</p> <p>Expanded operation restrictions:</p> <ul style="list-style-type: none"> • No cold startup below 5°C • Maximum altitude for the operating temperature must be 3050m (10,000ft) • Not supported: <ul style="list-style-type: none"> — Peripheral cards not qualified by Dell — Peripheral cards greater than 25W — PCIe SSD drives — GPU cards — Express flash — LRDIMM — Non-redundant PSU configurations
Temperature	
Operating	See Fresh Air for temperature information
Storage	-40°C to 65°C (-40°F to 149°F) with a maximum temperature gradation of 20°C per hour
Relative humidity	
Operating	See Dell Fresh Air for relative humidity information
Storage	5% to 95% at a maximum wet bulb temperature of 33°C (91°F); atmosphere must be non-condensing at all times
Maximum vibration	
Operating	0.26 Grms at 5Hz to 350Hz in all orientations



Storage 1.87 Grms at 10Hz to 500Hz for 15 minutes (all six sides tested)

Maximum shock

Operating Half sine shock in all operational orientations of 31G +/- 5% with a pulse duration of 2.6ms +/- 10%

Storage Half sine shock on all six sides of 71G +/- 5% with a pulse duration of 2ms +/-10%; square wave shock on all six sides of 27G with velocity change at 235 in/sec or greater

Altitude

Operating -15.2m to 3048m (-50 ft to 10,000 ft)

Storage -15.2m to 12,000m (-50 ft to 39,370 ft)

Airborne contaminant level

Class G1 or lower as defined by ISA-S71.04-1985

Power supply specifications

Table 27 lists power supply specifications for the PowerEdge R320.

Table 27. Power supply specifications

Specification	Redundant 550W	Redundant 350W	Non-redundant 350W
Current consumption	7.4–3.7A	4.8–2.4A	4.8–2.4A
Supply voltage	100–240VAC ¹	100–240VAC ¹	100–240VAC ¹
Frequency	50/60Hz	50/60Hz	50/60Hz
Heat dissipation (BTU/hr max)	2133	1356	1531
Maximum inrush current²	55A	55A	55A

¹Auto-ranging

²Under typical line conditions and over the entire system ambient operating range, the inrush current may reach 55A per power supply for 10ms or less.

Rack rail specifications

Table 28 lists the spacing dimensions for the R320 sliding and static rails.

Table 28. Rail adjustability range

Product	Rail identifier	Rail type	Rail adjustability range (mm)						Rail depth (mm)	
			Square		Round		Threaded		without CMA	with CMA
			Min	Max	Min	Max	Min	Max		
R320	A7	Sliding	681	868	667	861	681	883	720	845
	A8	Static	608	879	594	872	604	890	622	–

The adjustment range of the rails is a function of the type of rack in which they are being mounted. The min-max values listed above represent the allowable distance between the front and rear mounting flanges in the rack. Rail depth without the CMA represents the minimum depth of the rails with the outer CMA brackets removed (if applicable) as measured from the front mounting flanges of the rack.



USB peripherals

USB peripherals are supported through the front and back USB ports on the R320. These ports are USB 2.0 compliant.



Appendix B. Standards compliance

The Dell PowerEdge R320 conforms to the industry standards listed in Table 29.

Table 29. Industry standards documentation

Standard	URL for information and specifications
ACPI Advance Configuration and Power Interface Specification, v2.0c	acpi.info
Ethernet IEEE 802.3-2005	standards.ieee.org/getieee802/802.3.html
HDG Hardware Design Guide Version 3.0 for Microsoft Windows Server	microsoft.com/whdc/system/platform/pcdesign/desguide/serverdg.msp
IPMI Intelligent Platform Management Interface, v2.0	intel.com/design/servers/ipmi
DDR3 Memory DDR3 SDRAM Specification, Rev. 3A	jedec.org/download/search/JESD79-3C.pdf
LPC Low Pin Count Interface Specification, Rev. 1.1	developer.intel.com/design/chipsets/industry/lpc.htm
PCI Express PCI Express Base Specification Rev. 2.0 and 3.0	pcsig.com/specifications/pciexpress
PMBus Power System Management Protocol Specification, v1.2	pmbus.info/specs.html
SAS Serial Attached SCSI, v1.1	t10.org
SATA Serial ATA Rev. 2.6; SATA II, SATA 1.0a Extensions, Rev. 1.2	sata-io.org
SMBIOS System Management BIOS Reference Specification, v2.7	dmtf.org/standards/smbios
TPM Trusted Platform Module Specification, v1.2	trustedcomputinggroup.org
UEFI Unified Extensible Firmware Interface Specification, v2.1	uefi.org/specs
USB Universal Serial Bus Specification, Rev. 2.0	usb.org/developers/docs
Windows Logo Windows Logo Program System and Device Requirements, v3.10	microsoft.com/whdc/winlogo/hwrequirements.msp



Appendix C. Additional resources

Table 30 provides a list of documents and websites that provide for more information on the Dell PowerEdge R320.

Table 30. Additional resources

Resource	Description of contents	Location
Dell PowerEdge R320 Systems Owner's Manual	This manual, available in PDF format, provides the following information: <ul style="list-style-type: none">• Chassis features• System Setup program• System messages• System codes and indicators• System BIOS• Remove and replace procedures• Troubleshooting• Diagnostics• Jumpers and connectors	Dell.com/Support/Manuals
Dell PowerEdge R320 Getting Started Guide	This guide is printed and shipped with the system, and is also available in PDF format on the Dell support site. This guide provides information on the following: <ul style="list-style-type: none">• Initial setup steps• Key system features• Technical specifications	Dell.com/Support/Manuals
Rack Installation Instructions	This printed document is provided with the rack kits. The document provides the instructions for installing the server in a rack.	Dell.com/Support/Manuals
Cable Management Arm Installation Instructions	This printed document is provided with the CMA kits. The document provides the instructions for installing the cable management arm on the rails.	Dell.com/Support/Manuals
Information Update	This document is printed and shipped with the system, and is also available in PDF format on the Dell support site. This document provides information on system updates.	Dell.com/Support/Manuals
System Information Label	The system information label documents the system board layout and system jumper settings. Text is minimized due to space limitations and translation considerations. The label size is standardized across platforms.	Inside the system chassis cover
Quick Resource Locator (QRL)	This code on the chassis can be scanned by a phone application to access additional information and resources for the server, including videos, reference materials, service tag information and Dell contact	Inside the system chassis cover



Resource	Description of contents	Location
	information.	
Energy Smart Solution Advisor	The Dell Energy Smart Solution Advisor (ESSA) enables easier and more meaningful estimates to help you determine the most efficient configuration possible. Use ESSA to calculate the power consumption of your hardware, power infrastructure and storage.	Dell.com/ESSA
Power and cooling technologies	Provides details for improving energy efficiency in the data center.	Dell.com/PNC
Energy management	Provides information on Dell's Fresh Air cooling solutions.	Dell.com/FreshAir
Operating system matrix for Dell PowerEdge systems	Provides updated information on which operating systems are available on which PowerEdge systems.	Dell.com/OSsupport
Processor and chipset	Provides more information about the R320 processors and chipset.	Intel.com
Dell PowerEdge RAID controllers	Provides more information about Dell PERCs.	Dell.com/PERC
Power distribution unit	Provides help selecting a rack-based power distribution unit.	DellPDU.com
Uninterruptible power supply	Provides help selecting an uninterruptible power supply model.	DellUPS.com
Volatility information	Contact your Dell sales representative.	Dell.com/PowerEdge
Dell Enterprise Acoustics	White paper that explores the mechanisms of, people's reaction to, language of, and Dell's work to control noise from Enterprise products.	dell.com/downloads/global/products/pedge/en/acoustical-education-dell-enterprise-white-paper.pdf



Appendix D. System board block diagram

Figure 13. R320 system board block diagram

