

HP ProLiant BL465c Gen8 Server Blade Maintenance and Service Guide

Abstract

This guide describes identification and maintenance procedures, diagnostic tools, specifications and requirements for hardware components and software. This guide is for an experienced service technician. HP assumes you are qualified in the servicing of computer equipment, trained in recognizing hazards in products, and are familiar with weight and stability precautions.



Part Number: 661813-002
December 2012
Edition: 2

© Copyright 2012 Hewlett-Packard Development Company, L.P.

The information contained herein is subject to change without notice. The only warranties for HP products and services are set forth in the express warranty statements accompanying such products and services. Nothing herein should be construed as constituting an additional warranty. HP shall not be liable for technical or editorial errors or omissions contained herein.

Microsoft® and Windows® are U.S. registered trademarks of Microsoft Corporation.

AMD is a trademark of Advanced Micro Devices, Inc.

Contents

Customer self repair	5
Parts only warranty service	5
Illustrated parts catalog	15
Server blade components	15
Removal and replacement procedures	21
Required tools	21
Safety considerations	21
Preventing electrostatic discharge	21
Server blade warnings and cautions	21
Symbols on equipment	22
Server blade preparation	22
Power down the server blade	22
Remove the server blade	23
Access panel	24
Drive blank	25
Drive	25
Enclosure connector cover	26
DIMM baffle	27
DIMMs	28
Mezzanine assembly	29
Mezzanine card	31
FlexibleLOM	32
SAS controller	34
NAND flash module for the Smart Array P220i Controller	35
FBWC procedures	36
Removing the SAS controller capacitor pack	36
Removing the mezzanine option capacitor pack	37
Recovering data from the FBWC	38
Front panel/drive cage assembly	39
Heatsink blank	40
Serial label pull tab	41
Heatsink	42
Processor	44
System battery	48
System board	49
Server blade release lever assembly	56
HP Trusted Platform Module	59
Diagnostic tools	60
HP product QuickSpecs	60
HP ROM-Based Setup Utility	60
Using RBSU	60
HP Insight Diagnostics	61
HP Insight Diagnostics survey functionality	61
Active Health System	61

Integrated Management Log	62
USB support	62
Internal USB functionality	63
External USB functionality	63
Cabling	64
Cabling resources	64
Capacitor pack cabling	64
Drive cabling	65
Using the HP c-Class Blade SUV Cable	65
Connecting locally to a server blade with video and USB devices	65
Accessing a server blade with local KVM	65
Accessing local media devices	66
Troubleshooting	68
Troubleshooting resources	68
Component identification	69
Front panel components	69
Front panel LEDs and buttons	70
Drive LED definitions	71
System board components	71
System maintenance switch	72
Mezzanine connector definitions	73
DIMM slot locations	73
DIMM identification	74
Tool location	75
HP c-Class Blade SUV Cable	75
Specifications	76
Environmental specifications	76
Server blade specifications	76
Acronyms and abbreviations	77
Documentation feedback	79
Index	80

Customer self repair

HP products are designed with many Customer Self Repair (CSR) parts to minimize repair time and allow for greater flexibility in performing defective parts replacement. If during the diagnosis period HP (or HP service providers or service partners) identifies that the repair can be accomplished by the use of a CSR part, HP will ship that part directly to you for replacement. There are two categories of CSR parts:

- **Mandatory**—Parts for which customer self repair is mandatory. If you request HP to replace these parts, you will be charged for the travel and labor costs of this service.
- **Optional**—Parts for which customer self repair is optional. These parts are also designed for customer self repair. If, however, you require that HP replace them for you, there may or may not be additional charges, depending on the type of warranty service designated for your product.

NOTE: Some HP parts are not designed for customer self repair. In order to satisfy the customer warranty, HP requires that an authorized service provider replace the part. These parts are identified as "No" in the Illustrated Parts Catalog.

Based on availability and where geography permits, CSR parts will be shipped for next business day delivery. Same day or four-hour delivery may be offered at an additional charge where geography permits. If assistance is required, you can call the HP Technical Support Center and a technician will help you over the telephone. HP specifies in the materials shipped with a replacement CSR part whether a defective part must be returned to HP. In cases where it is required to return the defective part to HP, you must ship the defective part back to HP within a defined period of time, normally five (5) business days. The defective part must be returned with the associated documentation in the provided shipping material. Failure to return the defective part may result in HP billing you for the replacement. With a customer self repair, HP will pay all shipping and part return costs and determine the courier/carrier to be used.

For more information about HP's Customer Self Repair program, contact your local service provider. For the North American program, refer to the HP website (<http://www.hp.com/go/selfrepair>).

Parts only warranty service

Your HP Limited Warranty may include a parts only warranty service. Under the terms of parts only warranty service, HP will provide replacement parts free of charge.

For parts only warranty service, CSR part replacement is mandatory. If you request HP to replace these parts, you will be charged for the travel and labor costs of this service.

Réparation par le client (CSR)

Les produits HP comportent de nombreuses pièces CSR (Customer Self Repair = réparation par le client) afin de minimiser les délais de réparation et faciliter le remplacement des pièces défectueuses. Si pendant la période de diagnostic, HP (ou ses partenaires ou mainteneurs agréés) détermine que la réparation peut être effectuée à l'aide d'une pièce CSR, HP vous l'envoie directement. Il existe deux catégories de pièces CSR:

Obligatoire - Pièces pour lesquelles la réparation par le client est obligatoire. Si vous demandez à HP de remplacer ces pièces, les coûts de déplacement et main d'œuvre du service vous seront facturés.

Facultatif - Pièces pour lesquelles la réparation par le client est facultative. Ces pièces sont également conçues pour permettre au client d'effectuer lui-même la réparation. Toutefois, si vous demandez à HP de remplacer ces pièces, l'intervention peut ou non vous être facturée, selon le type de garantie applicable à votre produit.

REMARQUE: Certaines pièces HP ne sont pas conçues pour permettre au client d'effectuer lui-même la réparation. Pour que la garantie puisse s'appliquer, HP exige que le remplacement de la pièce soit effectué par un Mainteneur Agréé. Ces pièces sont identifiées par la mention "Non" dans le Catalogue illustré.

Les pièces CSR sont livrées le jour ouvré suivant, dans la limite des stocks disponibles et selon votre situation géographique. Si votre situation géographique le permet et que vous demandez une livraison le jour même ou dans les 4 heures, celle-ci vous sera facturée. Pour bénéficier d'une assistance téléphonique, appelez le Centre d'assistance technique HP. Dans les documents envoyés avec la pièce de rechange CSR, HP précise s'il est nécessaire de lui retourner la pièce défectueuse. Si c'est le cas, vous devez le faire dans le délai indiqué, généralement cinq (5) jours ouvrés. La pièce et sa documentation doivent être retournées dans l'emballage fourni. Si vous ne retournez pas la pièce défectueuse, HP se réserve le droit de vous facturer les coûts de remplacement. Dans le cas d'une pièce CSR, HP supporte l'ensemble des frais d'expédition et de retour, et détermine la société de courses ou le transporteur à utiliser.

Pour plus d'informations sur le programme CSR de HP, contactez votre Mainteneur Agréé local. Pour plus d'informations sur ce programme en Amérique du Nord, consultez le site Web HP (<http://www.hp.com/go/selfrepair>).

Service de garantie "pièces seules"

Votre garantie limitée HP peut inclure un service de garantie "pièces seules". Dans ce cas, les pièces de rechange fournies par HP ne sont pas facturées.

Dans le cadre de ce service, la réparation des pièces CSR par le client est obligatoire. Si vous demandez à HP de remplacer ces pièces, les coûts de déplacement et main d'œuvre du service vous seront facturés.

Riparazione da parte del cliente

Per abbreviare i tempi di riparazione e garantire una maggiore flessibilità nella sostituzione di parti difettose, i prodotti HP sono realizzati con numerosi componenti che possono essere riparati direttamente dal cliente (CSR, Customer Self Repair). Se in fase di diagnostica HP (o un centro di servizi o di assistenza HP) identifica il guasto come riparabile mediante un ricambio CSR, HP lo spedisirà direttamente al cliente per la sostituzione. Vi sono due categorie di parti CSR:

Obbligatorie – Parti che devono essere necessariamente riparate dal cliente. Se il cliente ne affida la riparazione ad HP, deve sostenere le spese di spedizione e di manodopera per il servizio.

Opzionali – Parti la cui riparazione da parte del cliente è facultativa. Si tratta comunque di componenti progettati per questo scopo. Se tuttavia il cliente ne richiede la sostituzione ad HP, potrebbe dover sostenere spese aggiuntive a seconda del tipo di garanzia previsto per il prodotto.

NOTA: alcuni componenti HP non sono progettati per la riparazione da parte del cliente. Per rispettare la garanzia, HP richiede che queste parti siano sostituite da un centro di assistenza autorizzato. Tali parti sono identificate da un "No" nel Catalogo illustrato dei componenti.

In base alla disponibilità e alla località geografica, le parti CSR vengono spedite con consegna entro il giorno lavorativo seguente. La consegna nel giorno stesso o entro quattro ore è offerta con un supplemento di costo solo in alcune zone. In caso di necessità si può richiedere l'assistenza telefonica di un addetto del centro di supporto tecnico HP. Nel materiale fornito con una parte di ricambio CSR, HP specifica se il cliente deve restituire dei componenti. Qualora sia richiesta la resa ad HP del componente difettoso, lo si deve spedire ad HP entro un determinato periodo di tempo, generalmente cinque (5) giorni lavorativi. Il componente difettoso deve essere restituito con la documentazione associata nell'imballo di spedizione fornito. La mancata restituzione del componente può comportare la fatturazione del ricambio da parte di HP. Nel caso di riparazione da parte del cliente, HP sostiene tutte le spese di spedizione e resa e sceglie il corriere/vettore da utilizzare.

Per ulteriori informazioni sul programma CSR di HP contattare il centro di assistenza di zona. Per il programma in Nord America fare riferimento al sito Web HP (<http://www.hp.com/go/selfrepair>).

Servizio di garanzia per i soli componenti

La garanzia limitata HP può includere un servizio di garanzia per i soli componenti. Nei termini di garanzia del servizio per i soli componenti, HP fornirà gratuitamente le parti di ricambio.

Per il servizio di garanzia per i soli componenti è obbligatoria la formula CSR che prevede la riparazione da parte del cliente. Se il cliente invece richiede la sostituzione ad HP, dovrà sostenere le spese di spedizione e di manodopera per il servizio.

Customer Self Repair

HP Produkte enthalten viele CSR-Teile (Customer Self Repair), um Reparaturzeiten zu minimieren und höhere Flexibilität beim Austausch defekter Bauteile zu ermöglichen. Wenn HP (oder ein HP Servicepartner) bei der Diagnose feststellt, dass das Produkt mithilfe eines CSR-Teils repariert werden kann, sendet Ihnen HP dieses Bauteil zum Austausch direkt zu. CSR-Teile werden in zwei Kategorien unterteilt:

Zwingend – Teile, für die das Customer Self Repair-Verfahren zwingend vorgegeben ist. Wenn Sie den Austausch dieser Teile von HP vornehmen lassen, werden Ihnen die Anfahrt- und Arbeitskosten für diesen Service berechnet.

Optional – Teile, für die das Customer Self Repair-Verfahren optional ist. Diese Teile sind auch für Customer Self Repair ausgelegt. Wenn Sie jedoch den Austausch dieser Teile von HP vornehmen lassen möchten, können bei diesem Service je nach den für Ihr Produkt vorgesehenen Garantiebedingungen zusätzliche Kosten anfallen.

HINWEIS: Einige Teile sind nicht für Customer Self Repair ausgelegt. Um den Garantieanspruch des Kunden zu erfüllen, muss das Teil von einem HP Servicepartner ersetzt werden. Im illustrierten Teilekatalog sind diese Teile mit „No“ bzw. „Nein“ gekennzeichnet.

CSR-Teile werden abhängig von der Verfügbarkeit und vom Lieferziel am folgenden Geschäftstag geliefert. Für bestimmte Standorte ist eine Lieferung am selben Tag oder innerhalb von vier Stunden gegen einen Aufpreis verfügbar. Wenn Sie Hilfe benötigen, können Sie das HP technische Support Center anrufen und sich von einem Mitarbeiter per Telefon helfen lassen. Den Materialien, die mit einem CSR-Ersatzteil geliefert werden, können Sie entnehmen, ob das defekte Teil an HP zurückgeschickt werden muss. Wenn es erforderlich ist, das defekte Teil an HP zurückzuschicken, müssen Sie dies innerhalb eines vorgegebenen Zeitraums tun, in der Regel innerhalb von fünf (5) Geschäftstagen. Das defekte Teil muss mit der zugehörigen Dokumentation in der Verpackung zurückgeschickt werden, die im Lieferumfang enthalten ist. Wenn Sie das

defekte Teil nicht zurückschicken, kann HP Ihnen das Ersatzteil in Rechnung stellen. Im Falle von Customer Self Repair kommt HP für alle Kosten für die Lieferung und Rücksendung auf und bestimmt den Kurier-/Frachtdienst.

Weitere Informationen über das HP Customer Self Repair Programm erhalten Sie von Ihrem Servicepartner vor Ort. Informationen über das CSR-Programm in Nordamerika finden Sie auf der HP Website unter (<http://www.hp.com/go/selfrepair>).

Parts-only Warranty Service (Garantieservice ausschließlich für Teile)

Ihre HP Garantie umfasst möglicherweise einen Parts-only Warranty Service (Garantieservice ausschließlich für Teile). Gemäß den Bestimmungen des Parts-only Warranty Service stellt HP Ersatzteile kostenlos zur Verfügung.

Für den Parts-only Warranty Service ist das CSR-Verfahren zwingend vorgegeben. Wenn Sie den Austausch dieser Teile von HP vornehmen lassen, werden Ihnen die Anfahrt- und Arbeitskosten für diesen Service berechnet.

Reparaciones del propio cliente

Los productos de HP incluyen muchos componentes que el propio usuario puede reemplazar (*Customer Self Repair*, CSR) para minimizar el tiempo de reparación y ofrecer una mayor flexibilidad a la hora de realizar sustituciones de componentes defectuosos. Si, durante la fase de diagnóstico, HP (o los proveedores o socios de servicio de HP) identifica que una reparación puede llevarse a cabo mediante el uso de un componente CSR, HP le enviará dicho componente directamente para que realice su sustitución. Los componentes CSR se clasifican en dos categorías:

- **Obligatorio:** componentes para los que la reparación por parte del usuario es obligatoria. Si solicita a HP que realice la sustitución de estos componentes, tendrá que hacerse cargo de los gastos de desplazamiento y de mano de obra de dicho servicio.
- **Opcional:** componentes para los que la reparación por parte del usuario es opcional. Estos componentes también están diseñados para que puedan ser reparados por el usuario. Sin embargo, si precisa que HP realice su sustitución, puede o no conllevar costes adicionales, dependiendo del tipo de servicio de garantía correspondiente al producto.

NOTA: Algunos componentes no están diseñados para que puedan ser reparados por el usuario. Para que el usuario haga valer su garantía, HP pone como condición que un proveedor de servicios autorizado realice la sustitución de estos componentes. Dichos componentes se identifican con la palabra "No" en el catálogo ilustrado de componentes.

Según la disponibilidad y la situación geográfica, los componentes CSR se enviarán para que lleguen a su destino al siguiente día laborable. Si la situación geográfica lo permite, se puede solicitar la entrega en el mismo día o en cuatro horas con un coste adicional. Si precisa asistencia técnica, puede llamar al Centro de asistencia técnica de HP y recibirá ayuda telefónica por parte de un técnico. Con el envío de materiales para la sustitución de componentes CSR, HP especificará si los componentes defectuosos deberán devolverse a HP. En aquellos casos en los que sea necesario devolver algún componente a HP, deberá hacerlo en el periodo de tiempo especificado, normalmente cinco días laborables. Los componentes defectuosos deberán devolverse con toda la documentación relacionada y con el embalaje de envío. Si no

enviara el componente defectuoso requerido, HP podrá cobrarle por el de sustitución. En el caso de todas sustituciones que lleve a cabo el cliente, HP se hará cargo de todos los gastos de envío y devolución de componentes y escogerá la empresa de transporte que se utilice para dicho servicio.

Para obtener más información acerca del programa de Reparaciones del propio cliente de HP, póngase en contacto con su proveedor de servicios local. Si está interesado en el programa para Norteamérica, visite la página web de HP siguiente (<http://www.hp.com/go/selfrepair>).

Servicio de garantía exclusivo de componentes

La garantía limitada de HP puede que incluya un servicio de garantía exclusivo de componentes. Según las condiciones de este servicio exclusivo de componentes, HP le facilitará los componentes de repuesto sin cargo adicional alguno.

Para este servicio de garantía exclusivo de componentes, es obligatoria la sustitución de componentes por parte del usuario (CSR). Si solicita a HP que realice la sustitución de estos componentes, tendrá que hacerse cargo de los gastos de desplazamiento y de mano de obra de dicho servicio.

Customer Self Repair

Veel onderdelen in HP producten zijn door de klant zelf te repareren, waardoor de reparatieduur tot een minimum beperkt kan blijven en de flexibiliteit in het vervangen van defecte onderdelen groter is. Deze onderdelen worden CSR-onderdelen (Customer Self Repair) genoemd. Als HP (of een HP Service Partner) bij de diagnose vaststelt dat de reparatie kan worden uitgevoerd met een CSR-onderdeel, verzendt HP dat onderdeel rechtstreeks naar u, zodat u het defecte onderdeel daarmee kunt vervangen. Er zijn twee categorieën CSR-onderdelen:

Verplicht: Onderdelen waarvoor reparatie door de klant verplicht is. Als u HP verzoekt deze onderdelen voor u te vervangen, worden u voor deze service reiskosten en arbeidsloon in rekening gebracht.

Optioneel: Onderdelen waarvoor reparatie door de klant optioneel is. Ook deze onderdelen zijn ontworpen voor reparatie door de klant. Als u echter HP verzoekt deze onderdelen voor u te vervangen, kunnen daarvoor extra kosten in rekening worden gebracht, afhankelijk van het type garantieservice voor het product.

OPMERKING: Sommige HP onderdelen zijn niet ontwikkeld voor reparatie door de klant. In verband met de garantievoorwaarden moet het onderdeel door een geautoriseerde Service Partner worden vervangen. Deze onderdelen worden in de geïllustreerde onderdelencatalogus aangemerkt met "Nee".

Afhankelijk van de leverbaarheid en de locatie worden CSR-onderdelen verzonden voor levering op de eerstvolgende werkdag. Levering op dezelfde dag of binnen vier uur kan tegen meerkosten worden aangeboden, indien dit mogelijk is gezien de locatie. Indien assistentie gewenst is, belt u een HP Service Partner om via de telefoon technische ondersteuning te ontvangen. HP vermeldt in de documentatie bij het vervangende CSR-onderdeel of het defecte onderdeel aan HP moet worden geretourneerd. Als het defecte onderdeel aan HP moet worden teruggezonden, moet u het defecte onderdeel binnen een bepaalde periode, gewoonlijk vijf (5) werkdagen, retourneren aan HP. Het defecte onderdeel moet met de bijbehorende documentatie worden geretourneerd in het meegeleverde verpakkingsmateriaal. Als u het defecte onderdeel niet terugzendt, kan HP u voor het vervangende onderdeel kosten in rekening brengen. Bij reparatie door de klant betaalt HP alle verzendkosten voor het vervangende en geretourneerde onderdeel en kiest HP zelf welke koerier/transportonderneming hiervoor wordt gebruikt.

Neem contact op met een Service Partner voor meer informatie over het Customer Self Repair programma van HP. Informatie over Service Partners vindt u op de HP website (<http://www.hp.com/go/selfrepair>).

Garantieservice "Parts Only"

Het is mogelijk dat de HP garantie alleen de garantieservice "Parts Only" omvat. Volgens de bepalingen van de Parts Only garantieservice zal HP kosteloos vervangende onderdelen ter beschikking stellen.

Voor de Parts Only garantieservice is vervanging door CSR-onderdelen verplicht. Als u HP verzoekt deze onderdelen voor u te vervangen, worden u voor deze service reiskosten en arbeidsloon in rekening gebracht.

Reparo feito pelo cliente

Os produtos da HP são projetados com muitas peças para reparo feito pelo cliente (CSR) de modo a minimizar o tempo de reparo e permitir maior flexibilidade na substituição de peças com defeito. Se, durante o período de diagnóstico, a HP (ou fornecedores/parceiros de serviço da HP) concluir que o reparo pode ser efetuado pelo uso de uma peça CSR, a peça de reposição será enviada diretamente ao cliente. Existem duas categorias de peças CSR:

Obrigatória – Peças cujo reparo feito pelo cliente é obrigatório. Se desejar que a HP substitua essas peças, serão cobradas as despesas de transporte e mão-de-obra do serviço.

Opcional – Peças cujo reparo feito pelo cliente é opcional. Essas peças também são projetadas para o reparo feito pelo cliente. No entanto, se desejar que a HP as substitua, pode haver ou não a cobrança de taxa adicional, dependendo do tipo de serviço de garantia destinado ao produto.

OBSERVAÇÃO: Algumas peças da HP não são projetadas para o reparo feito pelo cliente. A fim de cumprir a garantia do cliente, a HP exige que um técnico autorizado substitua a peça. Essas peças estão identificadas com a marca "No" (Não), no catálogo de peças ilustrado.

Conforme a disponibilidade e o local geográfico, as peças CSR serão enviadas no primeiro dia útil após o pedido. Onde as condições geográficas permitirem, a entrega no mesmo dia ou em quatro horas pode ser feita mediante uma taxa adicional. Se precisar de auxílio, entre em contato com o Centro de suporte técnico da HP para que um técnico o ajude por telefone. A HP especifica nos materiais fornecidos com a peça CSR de reposição se a peça com defeito deve ser devolvida à HP. Nos casos em que isso for necessário, é preciso enviar a peça com defeito à HP dentro do período determinado, normalmente cinco (5) dias úteis. A peça com defeito deve ser enviada com a documentação correspondente no material de transporte fornecido. Caso não o faça, a HP poderá cobrar a reposição. Para as peças de reparo feito pelo cliente, a HP paga todas as despesas de transporte e de devolução da peça e determina a transportadora/serviço postal a ser utilizado.

Para obter mais informações sobre o programa de reparo feito pelo cliente da HP, entre em contato com o fornecedor de serviços local. Para o programa norte-americano, visite o site da HP (<http://www.hp.com/go/selfrepair>).

Serviço de garantia apenas para peças

A garantia limitada da HP pode incluir um serviço de garantia apenas para peças. Segundo os termos do serviço de garantia apenas para peças, a HP fornece as peças de reposição sem cobrar nenhuma taxa.

No caso desse serviço, a substituição de peças CSR é obrigatória. Se desejar que a HP substitua essas peças, serão cobradas as despesas de transporte e mão-de-obra do serviço.

カスタマーセルフリペア

修理時間を短縮し、故障部品の交換における高い柔軟性を確保するために、HP製品には多数のCSR部品があります。診断の際に、CSR部品を使用すれば修理ができるとHP（HPまたはHP正規保守代理店）が判断した場合、HPはその部品を直接、お客様に発送し、お客様に交換していただきます。CSR部品には以下の2通りがあります。

- **必須** - カスタマーセルフリペアが必須の部品。当該部品について、もしもお客様がHPに交換作業を依頼される場合には、その修理サービスに関する交通費および人件費がお客様に請求されます。
- **任意** - カスタマーセルフリペアが任意である部品。この部品もカスタマーセルフリペア用です。当該部品について、もしもお客様がHPに交換作業を依頼される場合には、お買い上げの製品に適用される保証サービス内容の範囲内においては、別途費用を負担していただくことなく保証サービスを受けることができます。

注： HP製品の一部の部品は、カスタマーセルフリペア用ではありません。製品の保証を継続するためには、HPまたはHP正規保守代理店による交換作業が必須となります。部品カタログには、当該部品がカスタマーセルフリペア除外品である旨が記載されています。

部品供給が可能な場合、地域によっては、CSR部品を翌営業日に届くように発送します。また、地域によっては、追加費用を負担いただくことにより同日または4時間以内に届くように発送することも可能な場合があります。サポートが必要なときは、HPの修理受付窓口にご連絡いただければ、技術者が電話でアドバイスします。交換用のCSR部品または同梱物には、故障部品をHPに返送する必要があるかどうかが表示されています。故障部品をHPに返送する必要がある場合は、指定期限内（通常は5営業日以内）に故障部品をHPに返送してください。故障部品を返送する場合は、届いた時の梱包箱に関連書類とともに入れてください。故障部品を返送しない場合、HPから部品費用が請求されます。カスタマーセルフリペアの際には、HPは送料および部品返送費を全額負担し、使用する宅配便会社や運送会社を指定します。

部品のみ保証サービス

HP保証サービスには、部品のみ保証サービスが適用される場合があります。このサービスでは、交換部品は無償で提供されます。

部品のみ保証サービスにおいては、CSR部品をお客様により交換作業していただくことが必須となります。当該部品について、もしもお客様がHPに交換作業を依頼される場合には、その修理サービスに関する交通費および人件費はお客様の負担となります。

客户自行维修

HP 产品提供许多客户自行维修 (CSR) 部件，以尽可能缩短维修时间和在更换缺陷部件方面提供更大的灵活性。如果在诊断期间 HP（或 HP 服务提供商或服务合作伙伴）确定可以通过使用 CSR 部件完成维修，HP 将直接把该部件发送给您进行更换。有两类 CSR 部件：

- **强制性的** — 要求客户必须自行维修的部件。如果您请求 HP 更换这些部件，则必须为该服务支付差旅费和人工费用。
- **可选的** — 客户可以选择是否自行维修的部件。这些部件也是为客户自行维修设计的。不过，如果您要求 HP 为您更换这些部件，则根据为您的产品指定的保修服务类型，HP 可能收取或不再收取任何附加费用。

注：某些 HP 部件的设计并未考虑客户自行维修。为了满足客户保修的需要，HP 要求授权服务提供商更换相关部件。这些部件在部件图解目录中标记为“否”。

CSR 部件将在下一个工作日发运（取决于备货情况和允许的地理范围）。在允许的地理范围内，可在当天或四小时内发运，但要收取额外费用。如果需要帮助，您可以致电 HP 技术支持中心，将会有技术人员通过电话为您提供帮助。HP 会在随更换的 CSR 部件发运的材料中指明是否必须将有缺陷的部件返还给 HP。如果要求您将有缺陷的部件返还给 HP，那么您必须在规定期限内（通常是五 (5) 个工作日）将缺陷部件发给 HP。有缺陷的部件必须随所提供的发运材料中的相关文件一起返还。如果未能送还有缺陷的部件，HP 可能会要求您支付更换费用。客户自行维修时，HP 将承担所有相关运输和部件返回费用，并指定快递商/承运商。

有关 HP 客户自行维修计划的详细信息，请与您当地的服务提供商联系。有关北美地区的计划，请访问 HP 网站 (<http://www.hp.com/go/selfrepair>)。

仅部件保修服务

您的 HP 有限保修服务可能涉及仅部件保修服务。根据仅部件保修服务条款的规定，HP 将免费提供更换的部件。

仅部件保修服务要求进行 CSR 部件更换。如果您请求 HP 更换这些部件，则必须为该服务支付差旅费和人工费用。

客戶自行維修

HP 產品設計了許多「客戶自行維修」(CSR) 的零件以減少維修時間，並且使得更換瑕疵零件時能有更大的彈性。如果在診斷期間 HP (或 HP 服務供應商或維修夥伴) 辨認出此項維修工作可以藉由使用 CSR 零件來完成，則 HP 將直接寄送該零件給您作更換。CSR 零件分為兩種類別：

- **強制的** — 客戶自行維修所使用的零件是強制性的。如果您要求 HP 更換這些零件，HP 將會向您收取此服務所需的外出費用與勞動成本。
- **選購的** — 客戶自行維修所使用的零件是選購的。這些零件也設計用於客戶自行維修之用。不過，如果您要求 HP 為您更換，則可能需要也可能不需要負擔額外的費用，端視針對此產品指定的保固服務類型而定。

備註：某些 HP 零件沒有消費者可自行維修的設計。為符合客戶保固，HP 需要授權的服務供應商更換零件。這些零件在圖示的零件目錄中，被標示為「否」。

基於材料取得及環境允許的情況下，CSR 零件將於下一個工作日以快遞寄送。在環境的允許下當天或四小時內送達，則可能需要額外的費用。若您需要協助，可致電「HP 技術支援中心」，會有一位技術人員透過電話來協助您。不論損壞的零件是否必須退回，HP 皆會在與 CSR 替換零件一起運送的材料中註明。若要將損壞的零件退回 HP，您必須在指定的一段時間內（通常為五 (5) 個工作天），將損壞的零件寄回 HP。損壞的零件必須與寄送資料中隨附的相關技術文件一併退還。如果無法退還損壞的零件，HP 可能要向您收取替換費用。針對客戶自行維修情形，HP 將負責所有運費及零件退還費用並指定使用何家快遞/貨運公司。

如需 HP 的「客戶自行維修」方案詳細資訊，請連絡您當地的服務供應商。至於北美方案，請參閱 HP 網站 (<http://www.hp.com/go/selfrepair>)。

僅限零件的保固服務

您的「HP 有限保固」可能包含僅限零件的保固服務。在僅限零件的保固服務情況下，HP 將免費提供替換零件。

針對僅限零件的保固服務，CSR 零件替換是強制性的。如果您要求 HP 更換這些零件，HP 將會向您收取此服務所需的外出費用與勞動成本。

고객 셀프 수리

HP 제품은 수리 시간을 최소화하고 결함이 있는 부품 교체 시 더욱 융통성을 발휘할 수 있도록 하기 위해 고객 셀프 수리(CSR) 부품을 다량 사용하여 설계되었습니다. 진단 기간 동안 HP(또는 HP 서비스 공급업체 또는 서비스 협력업체)에서 CSR 부품을 사용하여 수리가 가능하다고 판단되면 HP는 해당 부품을 바로 사용자에게 보내어 사용자가 교체할 수 있도록 합니다. CSR 부품에는 두 가지 종류가 있습니다.

- **고객 셀프 수리가 의무 사항인 필수 부품.** 사용자가 HP에 이 부품의 교체를 요청할 경우 이 서비스에 대한 출장비 및 작업비가 청구됩니다.
- **고객 셀프 수리가 선택 사항인 부품.** 이 부품들도 고객 셀프 수리가 가능하도록 설계되었습니다. 하지만 사용자가 HP에 이 부품의 교체를 요청할 경우 사용자가 구입한 제품에 해당하는 보증 서비스 유형에 따라 추가 비용 없이 교체가 가능할 수 있습니다.

참고: 일부 HP 부품은 고객 셀프 수리가 불가능하도록 설계되었습니다. HP는 만족스러운 고객 보증을 위해 공인 서비스 제공업체를 통해 부품을 교체하도록 하고 있습니다. 이러한 부품들은 Illustrated Parts Catalog에 "No"라고 표시되어 있습니다.

CSR 부품은 재고 상태와 지리적 조건이 허용하는 경우 다음 영업일 납품이 가능하도록 배송이 이루어집니다. 지리적 조건이 허용하는 경우 추가 비용이 청구되는 조건으로 당일 또는 4시간 배송이 가능할 수도 있습니다. 도움이 필요하시면 HP 기술 지원 센터로 전화하십시오. 전문 기술자가 전화로 도움을 줄 것입니다. HP는 결함이 발생한 부품을 HP로 반환해야 하는지 여부를 CSR 교체 부품과 함께 배송된 자료에 지정합니다. 결함이 발생한 부품을 HP로 반환해야 하는 경우에는 지정된 기간 내(통상 영업일 기준 5일)에 HP로 반환해야 합니다. 이 때 결함이 발생한 부품은 제공된 포장 재료에 넣어 관련 설명서와 함께 반환해야 합니다. 결함이 발생한 부품을 반환하지 않는 경우 HP가 교체 부품에 대해 비용을 청구할 수 있습니다. 고객 셀프 수리의 경우, HP는 모든 운송 및 부품 반환 비용을 부담하며 이용할 운송업체 및 택배 서비스를 결정합니다.

HP 고객 셀프 수리 프로그램에 대한 자세한 내용은 가까운 서비스 제공업체에 문의하십시오. 북미 지역의 프로그램에 대해서는 HP 웹 사이트(<http://www.hp.com/go/selfrepair>)를 참조하십시오.

부품 제공 보증 서비스

HP 제한 보증에는 부품 제공 보증 서비스가 포함될 수 있습니다. 이러한 경우 HP는 부품 제공 보증 서비스의 조건에 따라 교체 부품만을 무료로 제공합니다.

부품 제공 보증 서비스 제공 시 CSR 부품 교체는 의무 사항입니다. 사용자가 HP에 이 부품의 교체를 요청할 경우 이 서비스에 대한 출장비 및 작업비가 청구됩니다.

Illustrated parts catalog

Server blade components

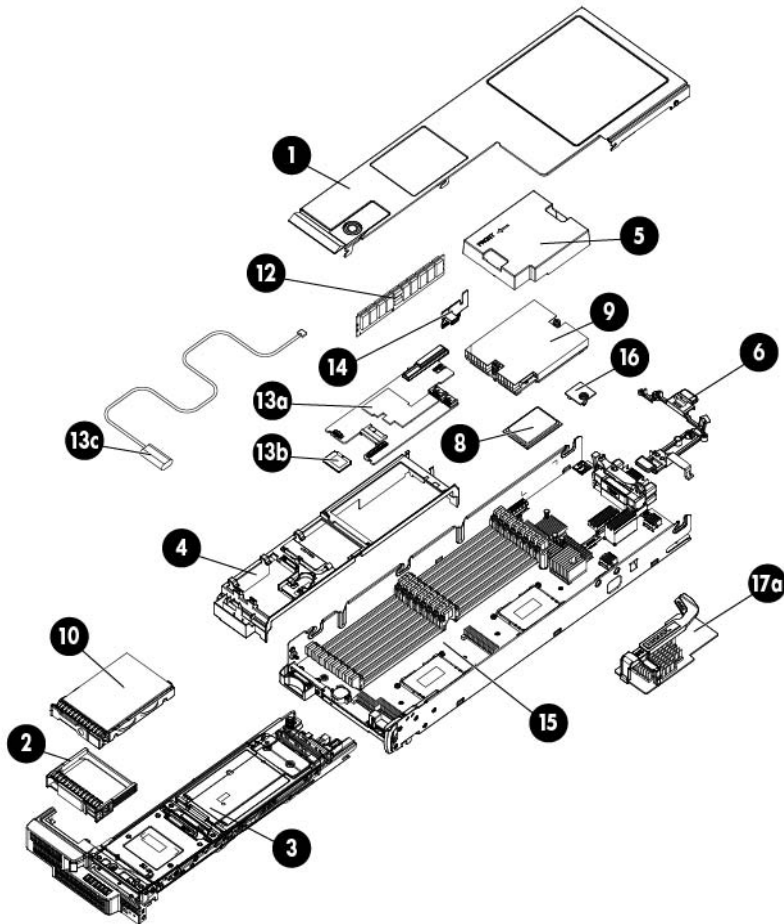

Item	Description	Spare part number	Customer self repair (on page 5)
	Mechanical components		
1	Access panel	686063-001	Mandatory ¹
2	Drive blank	670033-001	Mandatory ¹
3	Front panel/drive cage assembly	683820-001	Mandatory ¹
4	DIMM baffle	686062-001	Mandatory ¹
5	Heatsink blank	683819-001	Mandatory ¹
6	Mezzanine assembly	683822-001	Mandatory ¹
7	Hardware and plastics kit*	697743-001	Mandatory ¹
	a) Enclosure connector cover	—	—

Item	Description	Spare part number	Customer self repair (on page 5)
	b) Mezzanine assembly retainer assembly	—	—
	c) Mezzanine assembly guide pins (2)	—	—
	d) T-15 system board screws (2)	—	—
	e) Serial label pull tab	—	—
	System components		
8	Processors	—	—
	a) 2.5-GHz, AMD Opteron Model 6380**	705217-001	Optional ²
	b) 2.4-GHz, AMD Opteron Model 6378* **	705218-001	Optional ²
	c) 2.3-GHz, AMD Opteron Model 6376* **	705219-001	Optional ²
	d) 1.8-GHz, AMD Opteron Model 6366 HE* **	705225-001	Optional ²
	e) 2.8-GHz, AMD Opteron Model 6348* **	705220-001	Optional ²
	f) 2.6-GHz, AMD Opteron Model 6344* **	705221-001	Optional ²
	g) 3.2-GHz, AMD Opteron Model 6328* **	705222-001	Optional ²
	h) 2.8-GHz, AMD Opteron Model 6320* **	705223-001	Optional ²
	i) 3.5-GHz, AMD Opteron Model 6308* **	705224-001	Optional ²
	j) 2.4-GHz, AMD Opteron Model 6278* **	689494-001	Optional ²
	k) 2.3-GHz, AMD Opteron Model 6276* **	662834-001	Optional ²
	l) 2.2-GHz, AMD Opteron Model 6274* **	662835-001	Optional ²
	m) 2.2-GHz, AMD Opteron Model 6272* **	662836-001	Optional ²
	n) 1.6-GHz, AMD Opteron Model 6262 HE* **	662841-001	Optional ²
	o) 2.6-GHz, AMD Opteron Model 6238* **	662837-001	Optional ²
	p) 2.4-GHz, AMD Opteron Model 6234* **	662838-001	Optional ²
	q) 3.0-GHz, AMD Opteron Model 6220* **	662839-001	Optional ²
	r) 2.6-GHz, AMD Opteron Model 6212* **	662840-001	Optional ²
	s) 3.3-GHz, AMD Opteron Model 6204* **	672234-001	Optional ²
9	Heatsink		
	a) Processor 1 heatsink	672721-001	Optional ²
	b) Processor 2 heatsink*	672720-001	Optional ²
10	Hard drives, SFF	—	—
	a) 72-GB, SAS, 15,000-rpm, 6G	953949-001	Mandatory ¹
	b) 146-GB, SAS, 15,000-rpm, 6G*	653950-001	Mandatory ¹
	c) 300-GB, SAS, 15,000-rpm, 6G*	653960-001	Mandatory ¹
	d) 300-GB, SAS, 10,000-rpm, 6G*	653955-001	Mandatory ¹
	e) 450-GB, SAS, 10,000-rpm, 6G*	653956-001	Mandatory ¹
	f) 500-GB, SAS, 7,200-rpm, 6G*	653953-001	Mandatory ¹

Item	Description	Spare part number	Customer self repair (on page 5)
	g) 600-GB, SAS, 10,000-rpm, 6G*	653957-001	Mandatory ¹
	h) 900-GB, SAS, 10,000-rpm, 6G*	653971-001	Mandatory ¹
	i) 1-TB, SAS, 7,200-rpm, 6G*	653954-001	Mandatory ¹
	j) 500-GB, SATA, 7,200-rpm, 6G*	656107-001	Mandatory ¹
	k) 1-TB, SATA, 7,200-rpm, 6G*	656108-001	Mandatory ¹
11	Solid state drives, SFF*	—	—
	a) 200-GB, SAS, SLC, 6G	653961-001	Mandatory ¹
	b) 200-GB, SAS, MLC, 6G	658580-001	Mandatory ¹
	c) 400-GB, SAS, SLC, 6G	653962-001	Mandatory ¹
	d) 400-GB, SAS, MLC, 6G	653963-001	Mandatory ¹
	e) 800-GB, SAS, MLC, 6G	653964-001	Mandatory ¹
	f) 100-GB, SATA, MLC, 3G	653965-001	Mandatory ¹
	g) 200-GB, SATA, MLC, 3G	653966-001	Mandatory ¹
	h) 400-GB, SATA, MLC, 3G	653967-001	Mandatory ¹
	Boards		
12	DIMMs	—	—
	a) 32-GB, PC3L-10600L	687466-001	Mandatory ¹
	b) 16-GB, PC3-12800R*	688963-001	Mandatory ¹
	c) 16-GB, PC3L-10600R*	687464-001	Mandatory ¹
	d) 16-GB, PC3U-10600R*	687463-001	Mandatory ¹
	e) 8-GB, PC3-12800R*	687462-001	Mandatory ¹
	f) 8-GB, PC3L-10600R*	687461-001	Mandatory ¹
	g) 8-GB, PC3U-10600R*	687460-001	Mandatory ¹
	h) 4-GB, PC3-12800R*	687459-001	Mandatory ¹
	i) 4-GB, PC3L-10600R*	687458-001	Mandatory ¹
	j) 4-GB, PC3U-10600R*	687457-001	Mandatory ¹
13	Controller	—	—
	a) HP Smart Array P220i Controller with 512 MB FBWC	659331-001	Mandatory ¹
	b) NAND flash module for the HP Smart Array P220i Controller	686066-001	Mandatory ¹
	c) Capacitor pack with 61-cm (24-in) cable	686065-001	Mandatory ¹
	d) Capacitor pack cable, 61-cm (24-in)*	660092-001	Mandatory ¹
14	HP Smart Array P220i Pass Thru board	686067-001	Optional ²
15	System board with base pan	—	—
	a) System board assembly (supports 6200-series processors)	683821-001	Optional ²
	b) System board assembly (supports 6200/6300-series processors)	706568-001	Optional ²

Item	Description	Spare part number	Customer self repair (on page 5)
16	Trusted Platform Module	505836-001	No ³
17	FlexibleLOMs	—	—
	a) HP Ethernet 10Gb 2-port 560FLB FlexibleLOM	656243-001	Mandatory ¹
	b) HP Flex-10 10Gb 2-port 530FLB FlexibleLOM*	657132-001	Mandatory ¹
	c) HP FlexFabric 10Gb 2-port 554FLB FlexibleLOM*	649940-001	Mandatory ¹
18	Ethernet Mezzanine*	—	—
	a) HP Flex-10 10Gb 2-port 530M Adapter	657131-001	Mandatory ¹
	b) HP Flex-10 10Gb 2-port 552M Adapter	675484-001	Mandatory ¹
	c) HP FlexFabric 10Gb 2-port 554M Adapter	649870-001	Mandatory ¹
	d) HP Ethernet 1Gb 4P 366M Adapter	616010-001	Mandatory ¹
19	Fibre Channel mezzanine*	—	—
	a) HP LPe1 205A-HP 8Gb Fibre Channel Host Bus Adapter for BladeSystem c-Class	662538-001	Mandatory ¹
	b) HP QMH2572 8Gb Fibre Channel Host Bus Adapter	656452-001	Mandatory ¹
20	InfiniBand mezzanine*	—	—
	a) HP QDR/EN InfiniBand 10Gb Dual Port 544M Adapter	656087-001	Mandatory ¹
	b) HP FDR/EN InfiniBand 10/40Gb Dual Port 544M Adapter	656088-001	Mandatory ¹
	Miscellaneous		
21	System battery*	234556-001	Optional ²
22	Server blade release lever kit*	688895-001	Optional ²
	a) Server blade release lever assembly	—	—
	b) Server blade release lever bracket	—	—
	c) T-10 screws (2)	—	—
	Cables		
23	HP c-Class Blade SUV Cable*	416003-001	Mandatory ¹
24	Hard drive cable*	685775-001	Mandatory ¹

*Not shown

**Do not mix processors with different speeds or cache sizes.

¹Mandatory—Parts for which customer self repair is mandatory. If you request HP to replace these parts, you will be charged for the travel and labor costs of this service.

²Optional—Parts for which customer self repair is optional. These parts are also designed for customer self repair. If, however, you require that HP replace them for you, there may or may not be additional charges, depending on the type of warranty service designated for your product.

³No—Some HP parts are not designed for customer self repair. In order to satisfy the customer warranty, HP requires that an authorized service provider replace the part. These parts are identified as "No" in the Illustrated Parts Catalog.

¹Mandatory: Obligatoire—Pièces pour lesquelles la réparation par le client est obligatoire. Si vous demandez à HP de remplacer ces pièces, les coûts de déplacement et main d'œuvre du service vous seront facturés.

²Optional: Facultatif—Pièces pour lesquelles la réparation par le client est facultative. Ces pièces sont également conçues pour permettre au client d'effectuer lui-même la réparation. Toutefois, si vous demandez à HP de remplacer ces pièces, l'intervention peut ou non vous être facturée, selon le type de garantie applicable à votre produit.

³No: Non—Certaines pièces HP ne sont pas conçues pour permettre au client d'effectuer lui-même la réparation. Pour que la garantie puisse s'appliquer, HP exige que le remplacement de la pièce soit effectué par un Mainteneur Agréé. Ces pièces sont identifiées par la mention "Non" dans le Catalogue illustré.

¹Mandatory: Obbligatorie—Parti che devono essere necessariamente riparate dal cliente. Se il cliente ne affida la riparazione ad HP, deve sostenere le spese di spedizione e di manodopera per il servizio.

²Optional: Opzionali—Parti la cui riparazione da parte del cliente è facoltativa. Si tratta comunque di componenti progettati per questo scopo. Se tuttavia il cliente ne richiede la sostituzione ad HP, potrebbe dover sostenere spese addizionali a seconda del tipo di garanzia previsto per il prodotto.

³No: Non CSR—Alcuni componenti HP non sono progettati per la riparazione da parte del cliente. Per rispettare la garanzia, HP richiede che queste parti siano sostituite da un centro di assistenza autorizzato. Tali parti sono identificate da un "No" nel Catalogo illustrato dei componenti.

¹Mandatory: Zwingend—Teile, die im Rahmen des Customer Self Repair Programms ersetzt werden müssen. Wenn Sie diese Teile von HP ersetzen lassen, werden Ihnen die Versand- und Arbeitskosten für diesen Service berechnet.

²Optional: Optional—Teile, für die das Customer Self Repair-Verfahren optional ist. Diese Teile sind auch für Customer Self Repair ausgelegt. Wenn Sie jedoch den Austausch dieser Teile von HP vornehmen lassen möchten, können bei diesem Service je nach den für Ihr Produkt vorgesehenen Garantiebedingungen zusätzliche Kosten anfallen.

³No: Kein—Einige Teile sind nicht für Customer Self Repair ausgelegt. Um den Garantieanspruch des Kunden zu erfüllen, muss das Teil von einem HP Servicepartner ersetzt werden. Im illustrierten Teilekatalog sind diese Teile mit „No“ bzw. „Nein“ gekennzeichnet.

¹Mandatory: Obligatorio—componentes para los que la reparación por parte del usuario es obligatoria. Si solicita a HP que realice la sustitución de estos componentes, tendrá que hacerse cargo de los gastos de desplazamiento y de mano de obra de dicho servicio.

²Optional: Opcional— componentes para los que la reparación por parte del usuario es opcional. Estos componentes también están diseñados para que puedan ser reparados por el usuario. Sin embargo, si precisa que HP realice su sustitución, puede o no conllevar costes adicionales, dependiendo del tipo de servicio de garantía correspondiente al producto.

³No: No—Algunos componentes no están diseñados para que puedan ser reparados por el usuario. Para que el usuario haga valer su garantía, HP pone como condición que un proveedor de servicios autorizado realice la sustitución de estos componentes. Dichos componentes se identifican con la palabra "No" en el catálogo ilustrado de componentes.

¹Mandatory: Verplicht—Onderdelen waarvoor Customer Self Repair verplicht is. Als u HP verzoekt deze onderdelen te vervangen, komen de reiskosten en het arbeidsloon voor uw rekening.

²Optional: Optioneel—Onderdelen waarvoor reparatie door de klant optioneel is. Ook deze onderdelen zijn ontworpen voor reparatie door de klant. Als u echter HP verzoekt deze onderdelen voor u te vervangen, kunnen daarvoor extra kosten in rekening worden gebracht, afhankelijk van het type garantieservice voor het product.

³No: Nee—Sommige HP onderdelen zijn niet ontwikkeld voor reparatie door de klant. In verband met de garantievoorwaarden moet het onderdeel door een geautoriseerde Service Partner worden vervangen. Deze onderdelen worden in de geïllustreerde onderdelencatalogus aangemerkt met "Nee".

¹Mandatory: Obrigatória—Peças cujo reparo feito pelo cliente é obrigatório. Se desejar que a HP substitua essas peças, serão cobradas as despesas de transporte e mão-de-obra do serviço.

²Optional: Opcional—Peças cujo reparo feito pelo cliente é opcional. Essas peças também são projetadas para o reparo feito pelo cliente. No entanto, se desejar que a HP as substitua, pode haver ou não a cobrança de taxa adicional, dependendo do tipo de serviço de garantia destinado ao produto.

³No: Nenhuma—Algumas peças da HP não são projetadas para o reparo feito pelo cliente. A fim de cumprir a garantia do cliente, a HP exige que um técnico autorizado substitua a peça. Essas peças estão identificadas com a marca "No" (Não), no catálogo de peças ilustrado.

¹Mandatory : 必須 - 顧客自己修理が必須の部品。当該部品について、もしもお客様がHPに交換作業を依頼される場合には、その修理サービスに関する交通費および人件費がお客様に請求されます。

²Optional : 任意 - 顧客自己修理が任意である部品。この部品も顧客自己修理用です。当該部品について、もしもお客様がHPに交換作業を依頼される場合には、お買い上げの製品に適用される保証サービス内容の範囲内においては、費用を負担していただくことなく保証サービスを受けることができます。

³No : 除外 - HP製品の一部の部品は、顧客自己修理用ではありません。製品の保証を継続するためには、HPまたはHP正規保守代理店による交換作業が必須となります。部品カタログには、当該部品が顧客自己修理除外品である旨が記載されています。

¹Mandatory: 强制性的 — 要求客户必须自行维修的部件。如果您请求 HP 更换这些部件，则必须为该服务支付差旅费和人工费用。

²Optional: 可选的 — 客户可以选择是否自行维修的部件。这些部件也是为客户自行维修设计的。不过，如果您要求 HP 为您更换这些部件，则根据您的产品指定的保修服务类型，HP 可能收取或不再收取任何附加费用。

³No: 否 — 某些 HP 部件的设计并未考虑客户自行维修。为了满足客户保修的需要，HP 要求授权服务提供商更换相关部件。这些部件在部件图解目录中标记为“否”。

¹Mandatory: 強制的 — 客戶自行維修所使用的零件是強制性的。如果您要求 HP 更換這些零件，HP 將會向您收取此服務所需的外出費用與勞動成本。

²Optional: 選購的 — 客戶自行維修所使用的零件是選購的。這些零件也設計用於客戶自行維修之用。不過，如果您要求 HP 為您更換，則可能需要也可能不需要負擔額外的費用，端視針對此產品指定的保固服務類型而定。

³No: 否 — 某些 HP 零件沒有消費者可自行維修的設計。為符合客戶保固，HP 需要授權的服務供應商更換零件。這些零件在圖示的零件目錄中，被標示為「否」。

¹ Mandatory: 필수 — 고객 셀프 수리가 의무 사항인 필수 부품. 사용자가 HP에 이 부품의 교체를 요청할 경우 이 서비스에 대한 출장비 및 작업비가 청구됩니다.

² Optional: 옵션 — 고객 셀프 수리가 선택 사항인 부품. 이 부품들도 고객 셀프 수리가 가능하도록 설계되었습니다. 하지만 사용자가 HP에 이 부품의 교체를 요청할 경우 사용자가 구입한 제품에 해당하는 보증 서비스 유형에 따라 추가 비용 없이 교체가 가능할 수 있습니다.

³ No: No — 고객 셀프 수리가 불가능하도록 설계된 HP 부품. 이 부품들은 고객 셀프 수리가 불가능하도록 설계되었습니다. HP는 고객 보증을 만족시키기 위해 공인 서비스 제공업체를 통해 부품을 교체하도록 하고 있습니다.

Removal and replacement procedures

Required tools

You need the following items for some procedures:

- T-15 Torx screwdriver (provided on the DIMM baffle)
- T-10 Torx screwdriver (not provided with the server blade)
- HP Insight Diagnostics software ("[HP Insight Diagnostics](#)" on page 61)

Safety considerations

Before performing service procedures, review all the safety information.

Preventing electrostatic discharge

To prevent damaging the system, be aware of the precautions you need to follow when setting up the system or handling parts. A discharge of static electricity from a finger or other conductor may damage system boards or other static-sensitive devices. This type of damage may reduce the life expectancy of the device.

To prevent electrostatic damage:

- Avoid hand contact by transporting and storing products in static-safe containers.
- Keep electrostatic-sensitive parts in their containers until they arrive at static-free workstations.
- Place parts on a grounded surface before removing them from their containers.
- Avoid touching pins, leads, or circuitry.
- Always be properly grounded when touching a static-sensitive component or assembly.

Server blade warnings and cautions



WARNING: To reduce the risk of shock or injury from high-current electrical energy, do not remove the server blade access panel and then install the server blade into the enclosure.



WARNING: To reduce the risk of personal injury from hot surfaces, allow the drives and the internal system components to cool before touching them.



CAUTION: Do not operate the server blade with the access panel removed. Operating the server blade in this manner results in improper airflow and improper cooling that can lead to thermal damage.



CAUTION: When performing non-hot-plug operations, you must power down the server blade and/or the system. However, it may be necessary to leave the server blade powered up when performing other operations, such as hot-plug installations or troubleshooting.

Symbols on equipment

The following symbols may be placed on equipment to indicate the presence of potentially hazardous conditions.



This symbol indicates the presence of hazardous energy circuits or electric shock hazards. Refer all servicing to qualified personnel.

WARNING: To reduce the risk of injury from electric shock hazards, do not open this enclosure. Refer all maintenance, upgrades, and servicing to qualified personnel.



This symbol indicates the presence of electric shock hazards. The area contains no user or field serviceable parts. Do not open for any reason.

WARNING: To reduce the risk of injury from electric shock hazards, do not open this enclosure.



This symbol on an RJ-45 receptacle indicates a network interface connection.

WARNING: To reduce the risk of electric shock, fire, or damage to the equipment, do not plug telephone or telecommunications connectors into this receptacle.



This symbol indicates the presence of a hot surface or hot component. If this surface is contacted, the potential for injury exists.

WARNING: To reduce the risk of injury from a hot component, allow the surface to cool before touching.



6.3 kg
13.9 lb

This symbol indicates that the component exceeds the recommended weight for one individual to handle safely.

WARNING: To reduce the risk of personal injury or damage to the equipment, observe local occupational health and safety requirements and guidelines for manual material handling.



These symbols, on power supplies or systems, indicate that the equipment is supplied by multiple sources of power.

WARNING: To reduce the risk of injury from electric shock, remove all power cords to completely disconnect power from the system.

Server blade preparation

To service any internal server blade component, power down the server blade and remove it from the enclosure.

Power down the server blade

Before powering down the server blade for any upgrade or maintenance procedures, perform a backup of critical server data and programs.



IMPORTANT: When the server blade is in standby mode, auxiliary power is still being provided to the system.

Depending on the OA configuration, use one of the following methods to power down the server blade:

- Press and release the Power On/Standby button.

This method initiates a controlled shutdown of applications and the OS before the server blade enters standby mode.

- Press and hold the Power On/Standby button for more than 4 seconds to force the server blade to enter standby mode.

This method forces the server blade to enter standby mode without properly exiting applications and the OS. If an application stops responding, you can use this method to force a shutdown.

- Use a virtual power button selection through HP iLO.

This method initiates a controlled remote shutdown of applications and the OS before the server blade enters standby mode.

- Use the OA CLI to execute one of the following commands:

- `poweroff server [bay number]`

This command initiates a controlled shutdown of applications and the OS before the server blade enters standby mode.

- `poweroff server [bay number] force`

This form of the command forces the server blade to enter standby mode without properly exiting applications and the OS. If an application stops responding, this method forces a shutdown.

- Use the OA GUI to initiate a shutdown:

- a. Select the **Enclosure Information** tab.

- b. In the Device Bays item, select the **Overall** checkbox.

- c. From the Virtual Power menu, initiate a shutdown of applications and the OS:

- For a controlled shutdown, select **Momentary Press**.

- For an emergency shutdown, select **Press and Hold**.

Before proceeding, verify the server blade is in standby mode by observing that the system power LED is amber.

Remove the server blade

To remove the component:

1. Identify the proper server blade.
2. Power down the server blade (on page 22).

3. Remove the server blade.

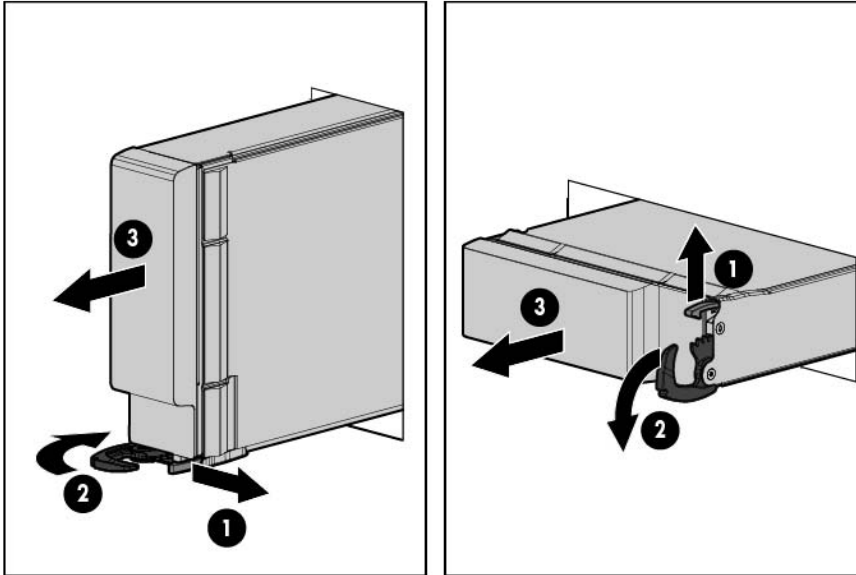

4. Place the server blade on a flat, level work surface.



WARNING: To reduce the risk of personal injury from hot surfaces, allow the drives and the internal system components to cool before touching them.



CAUTION: To prevent damage to electrical components, properly ground the server blade before beginning any installation procedure. Improper grounding can cause ESD.

Access panel

To remove the component:

1. Power down the server blade (on page 22).
2. Remove the server blade (on page 23).
3. Press the access panel release button.
4. Slide the access panel towards the rear of the server blade, and then lift to remove the panel.

To replace the component:

1. Place the access panel on top of the server blade.
2. Slide the access panel forward until it clicks into place.

Drive blank

Remove the component as indicated.

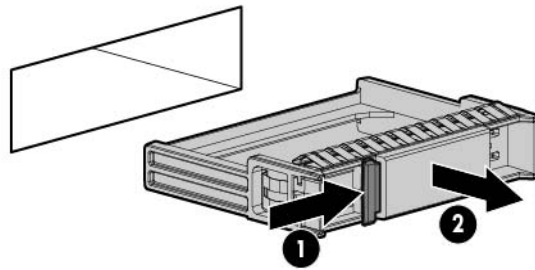

To replace the component, squeeze the release latch and slide the drive blank into the bay until it clicks into place.

Drive

To remove the component:

1. Determine the status of the drive from the drive LED definitions (on page 71).
2. Back up all server blade data on the drive.
3. Remove the drive.

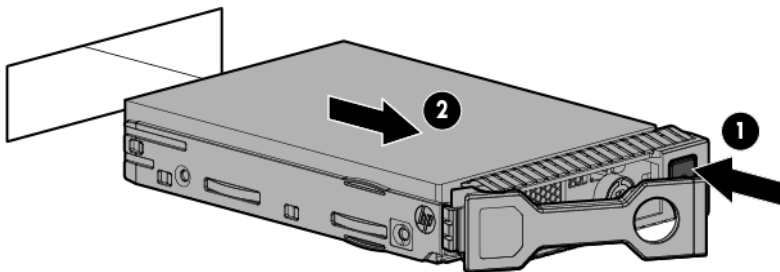

To replace the component:



CAUTION: To prevent improper cooling and thermal damage, do not operate the server blade or the enclosure unless all drive and device bays are populated with either a component or a blank.

1. Prepare the drive.

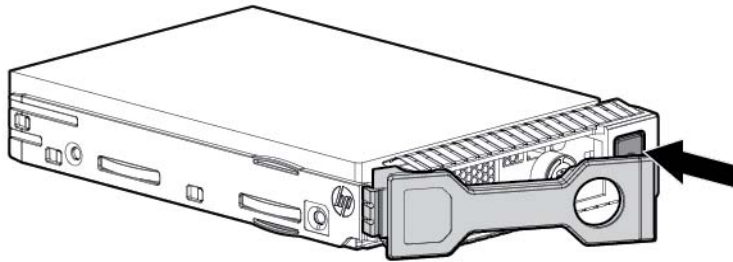

2. Install the drive.

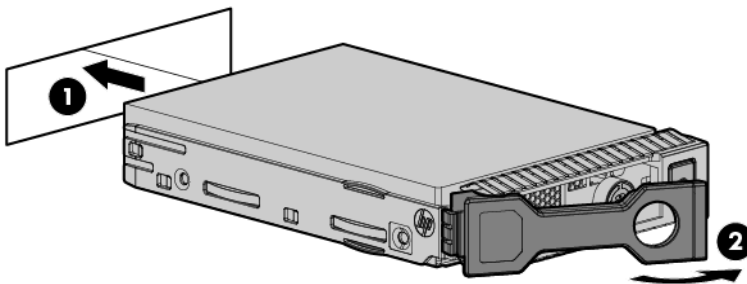

3. Determine the status of the drive from the drive LED definitions (on page 71).

Enclosure connector cover

To remove the component:

1. Place the server blade on a flat, level work surface.
2. Remove the enclosure connector cover.

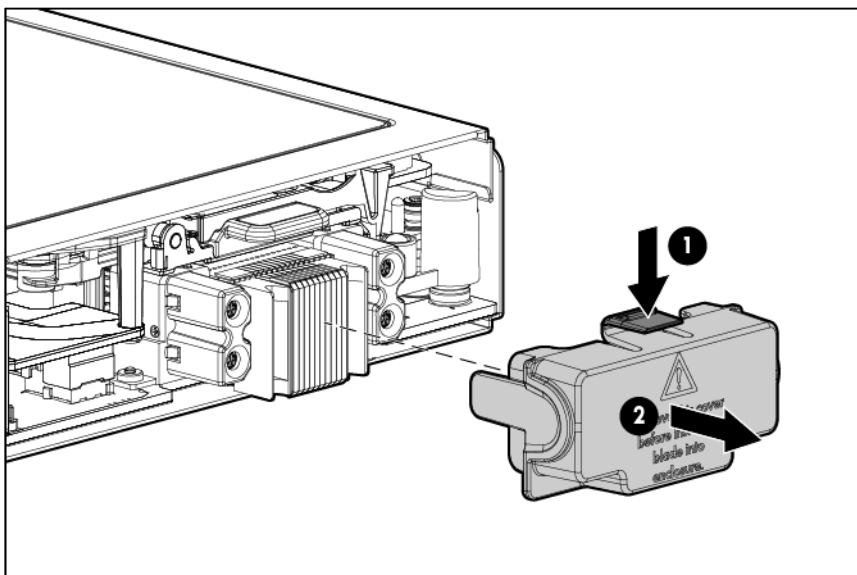

To replace the component, reverse the removal procedure.

DIMM baffle

To remove the component:

1. Power down the server blade (on page 22).
2. Remove the server blade (on page 23).
3. Remove the access panel ("Access panel" on page 24).

CAUTION: Always disconnect the drive cables from the SAS controller before removing the DIMM baffle. Failure to do so may result in damage to the SAS controller.

4. Disconnect the drive cables from the SAS controller.

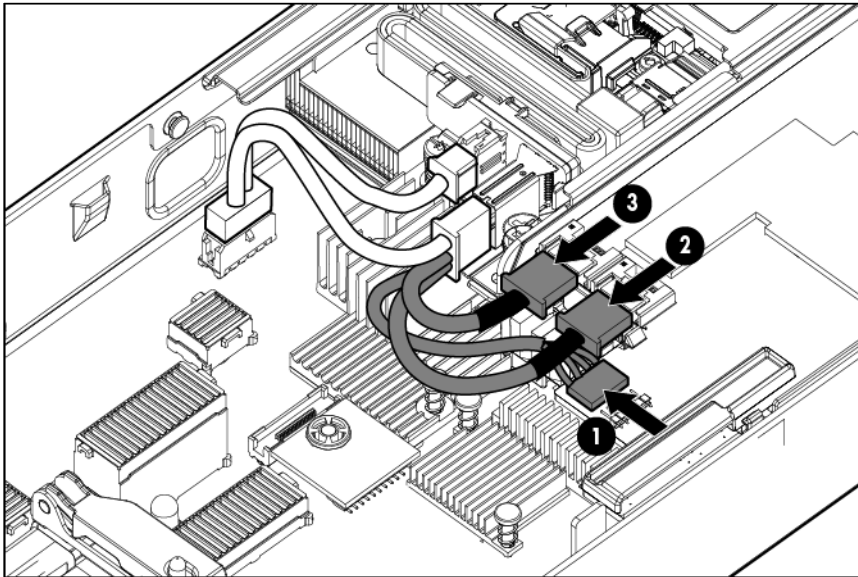

5. Remove the DIMM baffle.

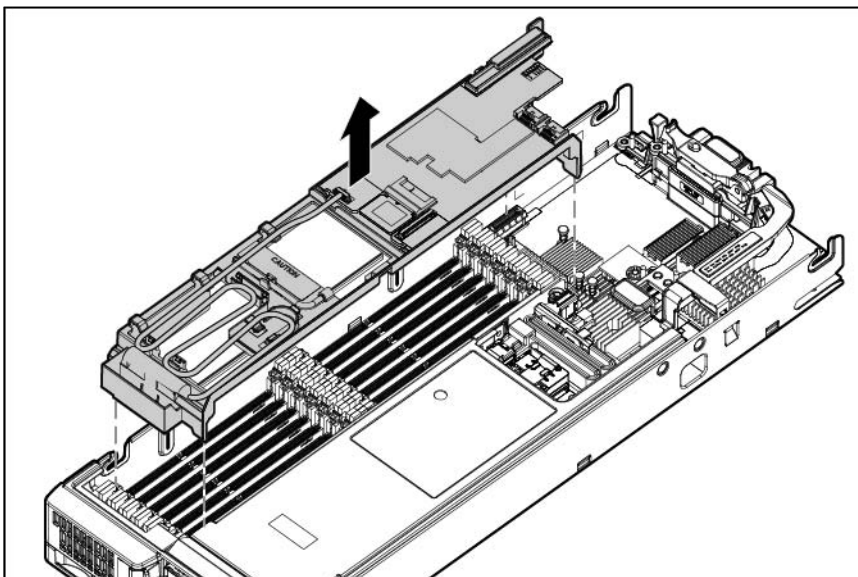

To replace the component:

1. Install the DIMM baffle.

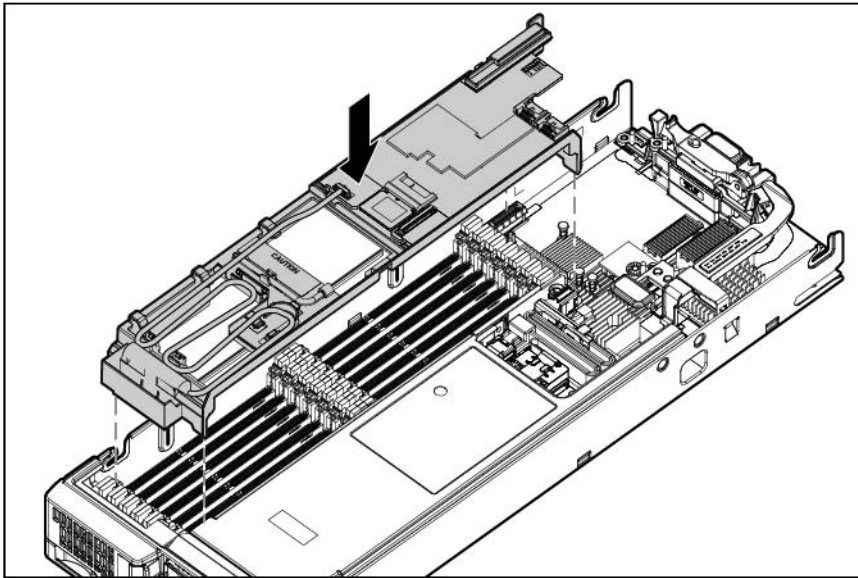

2. Connect the drive cable connectors to the SAS controller.

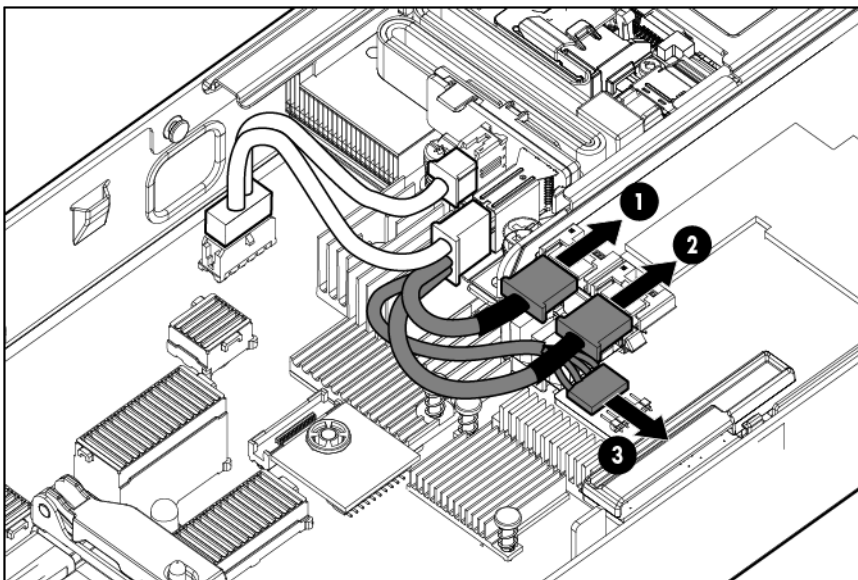

3. Install the access panel ("[Access panel](#)" on page [24](#)).

DIMMs



CAUTION: Use only HP DIMMs. DIMMs from other sources may adversely affect data integrity.

To identify the DIMMs installed in the server blade, see "[DIMM identification](#) (on page [74](#))."

To remove the component:

1. Power down the server blade (on page [22](#)).
2. Remove the server blade (on page [23](#)).

3. Remove the access panel ("[Access panel](#)" on page [24](#)).



CAUTION: Always disconnect the drive cables from the SAS controller before removing the DIMM baffle. Failure to do so may result in damage to the SAS controller.

4. Disconnect the drive cables from the SAS controller and remove the DIMM baffle ("[DIMM baffle](#)" on page [27](#)).
5. Remove the DIMM.

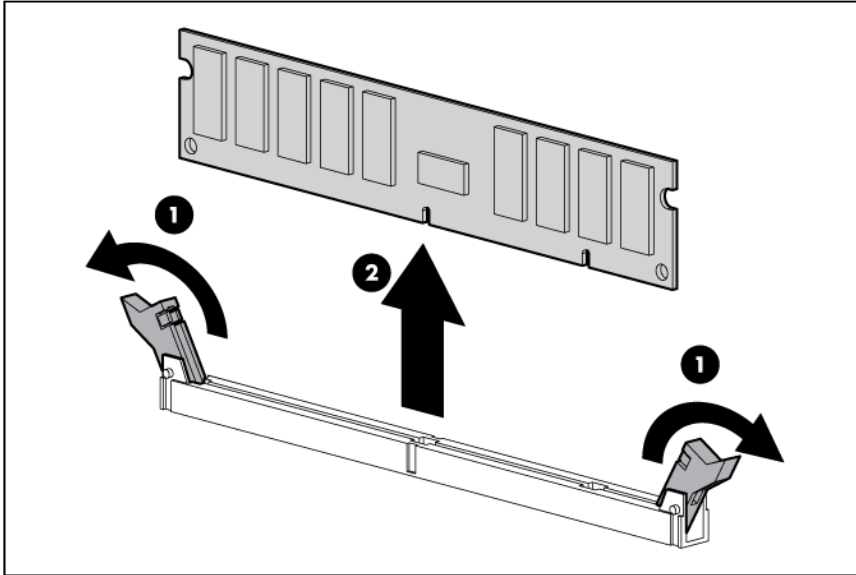

To replace the component, reverse the removal procedure.

Mezzanine assembly

To remove the component:

1. Power down the server blade (on page [22](#)).
2. Remove the server blade (on page [23](#)).
3. Remove the access panel ("[Access panel](#)" on page [24](#)).

4. Remove the mezzanine assembly from the server blade.

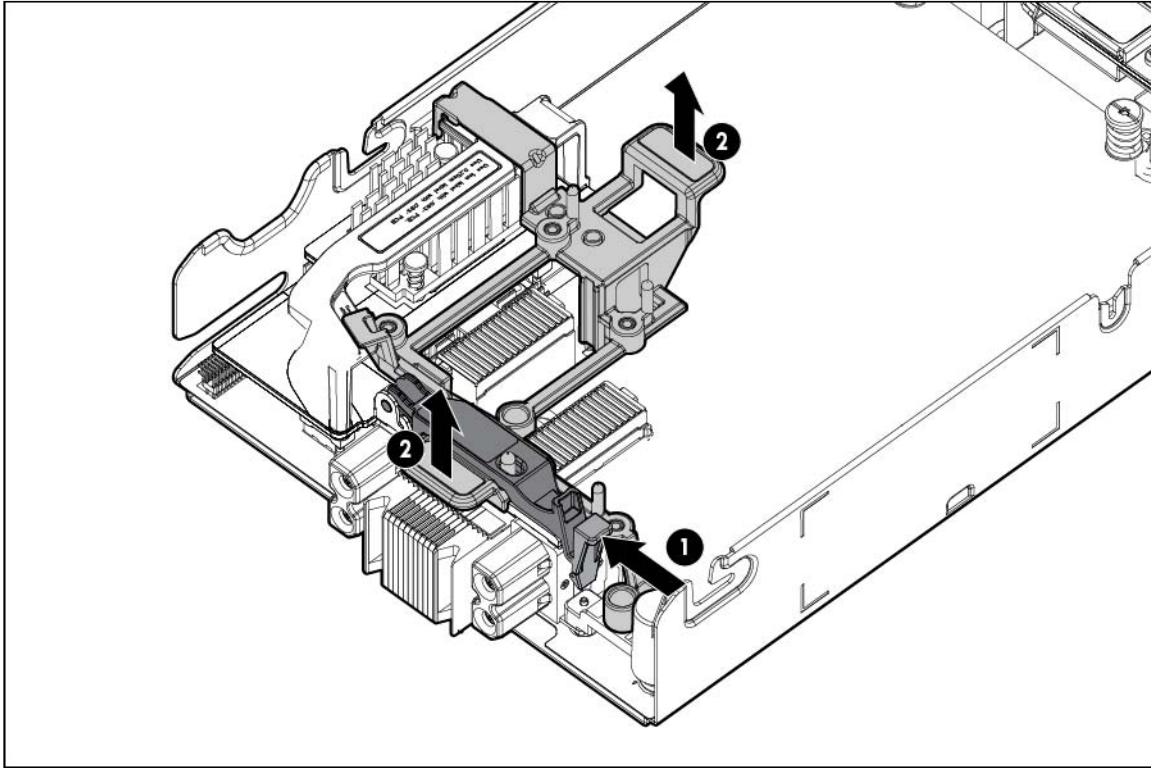

To replace the component:

1. Align the mezzanine assembly with the guide pins on the system board, and then install the mezzanine assembly on the system board.
2. Press down firmly on the mezzanine assembly handles, and then close the mezzanine assembly latch.

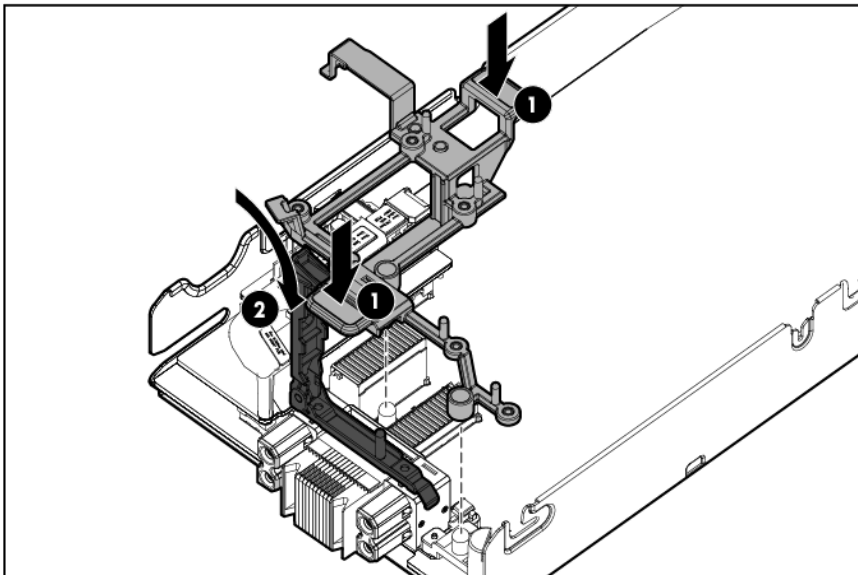

3. Install the access panel ("[Access panel](#)" on page 24).

Mezzanine card

To remove the component:

1. Power down the server blade (on page 22).
2. Remove the server blade (on page 23).
3. Remove the access panel ("Access panel" on page 24).
4. Remove the mezzanine assembly ("Mezzanine assembly" on page 29).
5. Remove the mezzanine card from the mezzanine assembly.

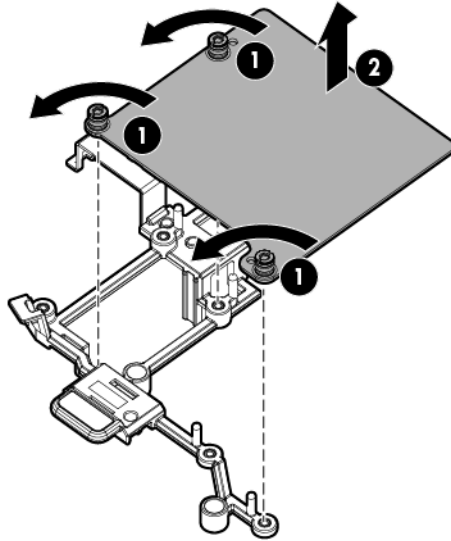

To replace the component:

1. Align the mezzanine card with the guide pins on the mezzanine assembly.

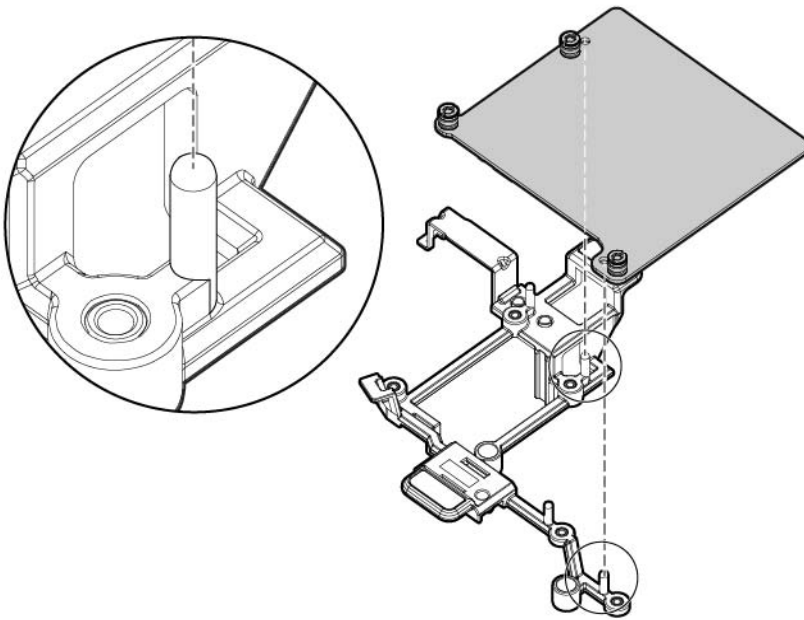

2. Install the mezzanine card in the mezzanine assembly, and then tighten the mezzanine card screws to secure the card to the mezzanine assembly.

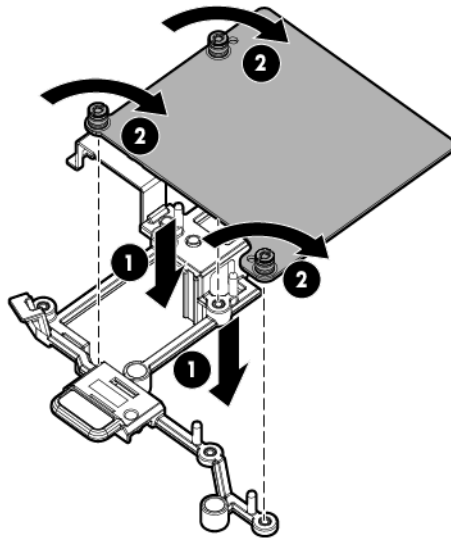

3. Align the mezzanine assembly with the guide pins on the system board, and then install the mezzanine assembly on the system board.
4. Press down firmly on the mezzanine assembly handles, and then close the mezzanine assembly latch.

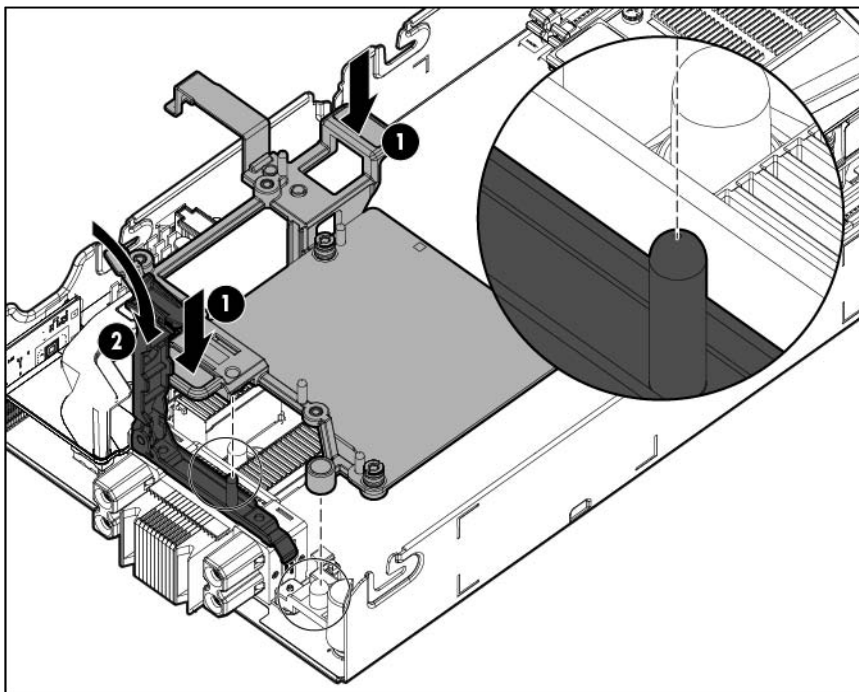

5. Install the access panel ("[Access panel](#)" on page 24).

FlexibleLOM

To remove the component:

1. Power down the server blade (on page 22).

2. Remove the server blade (on page 23).
3. Remove the access panel ("[Access panel](#)" on page 24).
4. Remove the mezzanine assembly ("[Mezzanine assembly](#)" on page 29).
5. Use the FlexibleLOM handle to remove the FlexibleLOM from the system board.

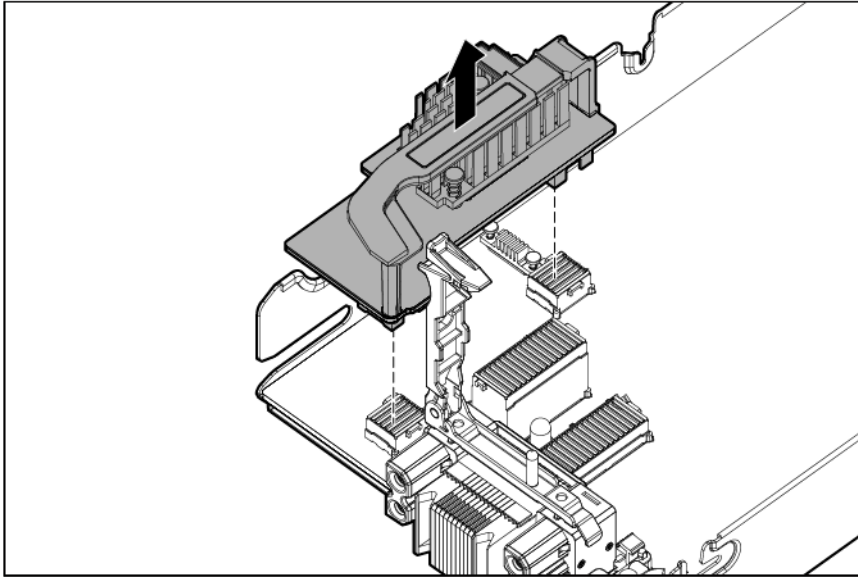

To replace the component:

1. Align and install the FlexibleLOM. Press down on the handle to seat the FlexibleLOM on the system board.

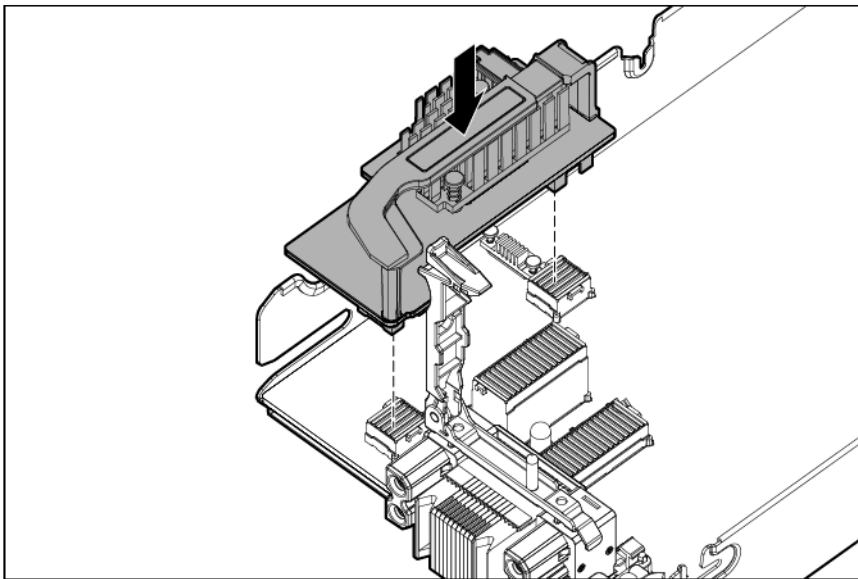

2. Install the mezzanine assembly ("[Mezzanine assembly](#)" on page 29).
3. Install the access panel ("[Access panel](#)" on page 24).

SAS controller

To remove the component:

1. Power down the server blade (on page 22).
2. Remove the server blade (on page 23).
3. Remove the access panel ("Access panel" on page 24).



CAUTION: Always disconnect the drive cables from the SAS controller before removing the DIMM baffle. Failure to do so may result in damage to the SAS controller.

4. Disconnect the drive cables from the SAS controller and remove the DIMM baffle ("DIMM baffle" on page 27).
5. Disconnect the capacitor pack cabling, if connected ("Capacitor pack cabling" on page 64).
6. Remove the SAS controller.

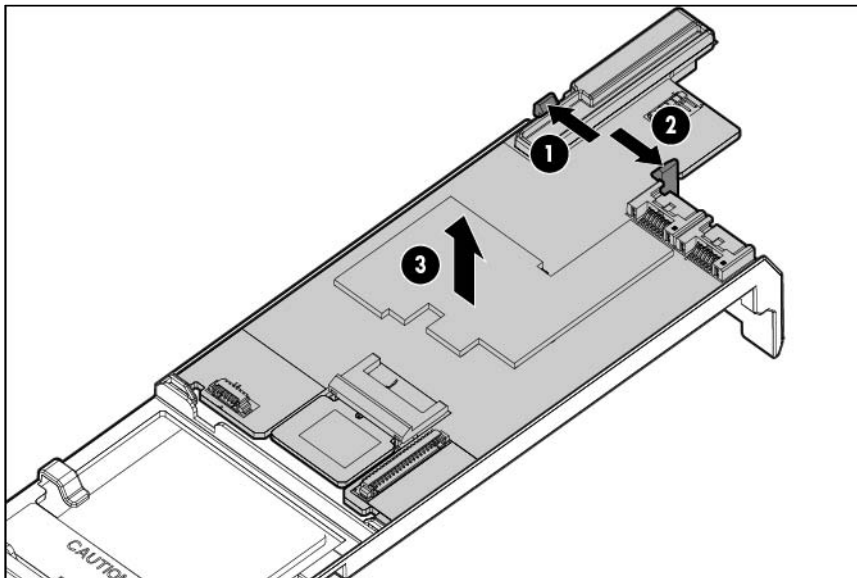

To replace the component:

1. Install the SAS controller.

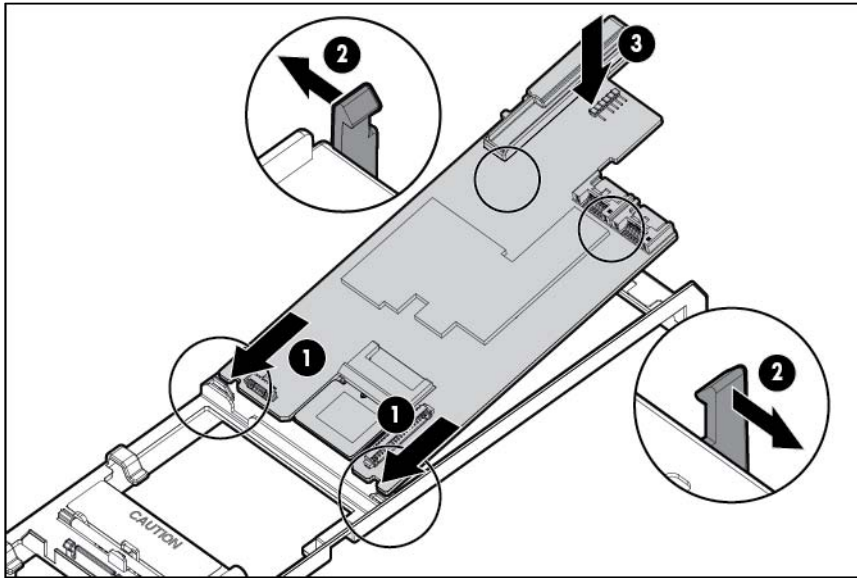

2. Install the DIMM baffle and connect the drive cable to the SAS controller ("[DIMM baffle](#)" on page [27](#)).
3. Install the access panel ("[Access panel](#)" on page [24](#)).

NAND flash module for the Smart Array P220i Controller

To remove the component:

1. Power down the server blade (on page [22](#)).
2. Remove the server blade (on page [23](#)).
3. Remove the access panel ("[Access panel](#)" on page [24](#)).



CAUTION: Always disconnect the drive cables from the SAS controller before removing the DIMM baffle. Failure to do so may result in damage to the SAS controller.

4. Disconnect the drive cables from the SAS controller and remove the DIMM baffle ("[DIMM baffle](#)" on page [27](#)).
5. Remove the SAS controller ("[SAS controller](#)" on page [34](#)).

6. Remove the NAND flash module from the Smart Array P220i Controller.

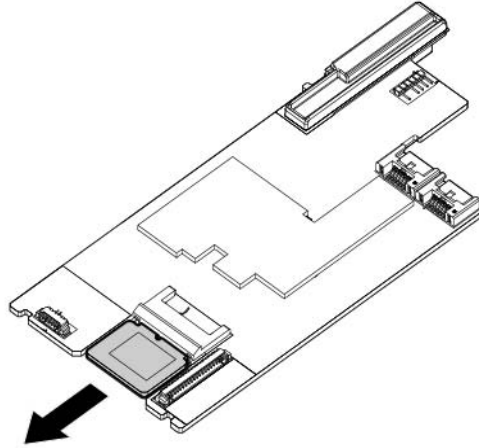

To replace the component, reverse the removal procedure.

FBWC procedures

Three types of procedures are provided for the FBWC option:

- Removing the SAS controller capacitor pack (on page [36](#))
- Removing the mezzanine option capacitor pack (on page [37](#))
- Recovering data from the FBWC (on page [38](#))

Removing the SAS controller capacitor pack

To remove the component:

1. Power down the server blade (on page [22](#)).
2. Remove the server blade (on page [23](#)).
3. Remove the access panel ("Access panel" on page [24](#)).
4. Disconnect the capacitor pack cable from the SAS controller.

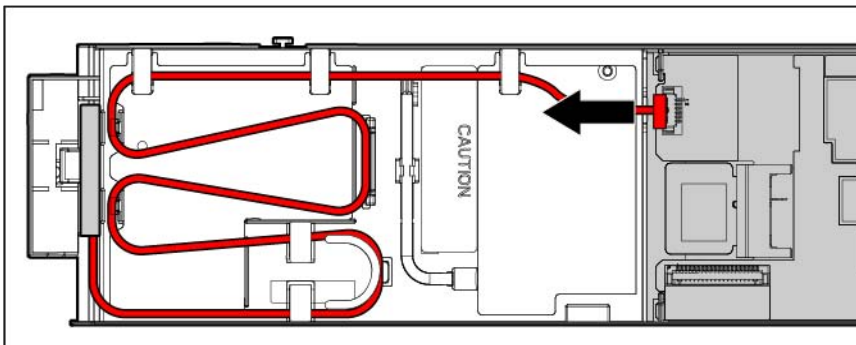

5. Disconnect the drive cables from the SAS controller and remove the DIMM baffle ("DIMM baffle" on page [27](#)).

6. Remove the capacitor pack.

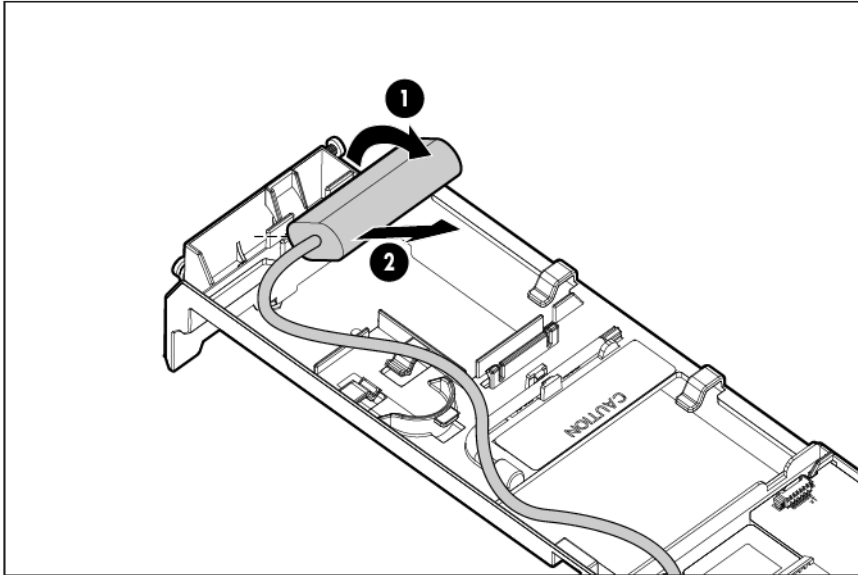

To replace the component, reverse the removal procedure.

Removing the mezzanine option capacitor pack

To remove the component:

1. Power down the server blade (on page 22).
2. Remove the server blade (on page 23).
3. Remove the access panel ("Access panel" on page 24).
4. Disconnect the drive cables from the SAS controller and remove the DIMM baffle ("DIMM baffle" on page 27).
5. Disconnect the capacitor pack cable from the mezzanine option.

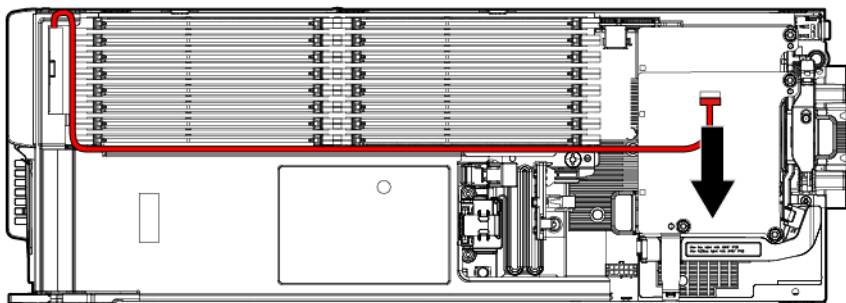

6. Remove the capacitor pack.

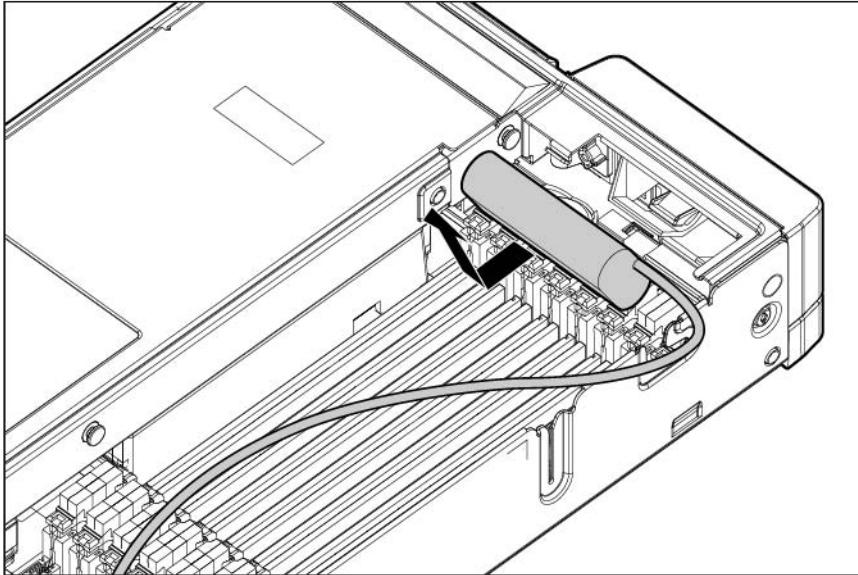

To replace the component, reverse the removal procedure.

Recovering data from the FBWC

If the server blade fails, use the following procedure to recover data temporarily stored in the FBWC.

CAUTION: Before starting this procedure, read the information about protecting against electrostatic discharge ("[Preventing electrostatic discharge](#)" on page 21).

1. Set up a recovery server blade station using an identical server blade model. Do not install any internal drives or FBWC in this server blade. (HP recommends this option.)
2. Power down the failed server blade ("[Power down the server blade](#)" on page 22).
3. Transfer the hard drives from the failed server blade to the recovery server blade station.
4. Remove the SAS controller (on page 34), NAND flash module ("[NAND flash module for the Smart Array P220i Controller](#)" on page 35), and capacitor pack ("[Removing the SAS controller capacitor pack](#)" on page 36) from the failed server blade, and install the controller, NAND flash module, and capacitor pack in the recovery server blade.
5. Power up the recovery server blade.

If data was saved on the NAND flash module, then a 1792 POST message appears, stating that valid data was flushed from the cache. This data is now stored on the drives in the recovery server blade.

If the SAS controller fails, use the following procedure to recover data temporarily stored in the FBWC.

CAUTION: Before starting this procedure, read the information about protecting against electrostatic discharge ("[Preventing electrostatic discharge](#)" on page 21).

1. Set up a recovery server blade station using an identical server blade model. Do not install any internal drives or FBWC in this server blade. (HP recommends this option.)
2. Power down the failed server blade ("[Power down the server blade](#)" on page 22).
3. Transfer the hard drives from the failed server blade to the recovery server blade station.

4. Remove the NAND flash module ("NAND flash module for the Smart Array P220i Controller" on page 35) and capacitor pack ("Removing the SAS controller capacitor pack" on page 36) from the failed server blade, and install the NAND flash module and capacitor pack in the recovery server blade.
5. Power up the recovery server blade.

If data was saved on the NAND flash module, then a 1792 POST message appears, stating that valid data was flushed from the cache. This data is now stored on the drives in the recovery server blade.

Front panel/drive cage assembly

To remove the component:

1. Power down the server blade (on page 22).
 2. Remove the server blade (on page 23).
 3. Remove the access panel ("Access panel" on page 24).
-
4. Disconnect the drive cables from the SAS controller and remove the DIMM baffle ("DIMM baffle" on page 27).
 5. Remove all hard drives ("Drive" on page 25).
 6. Extend the serial label pull tab from the front of the server blade.

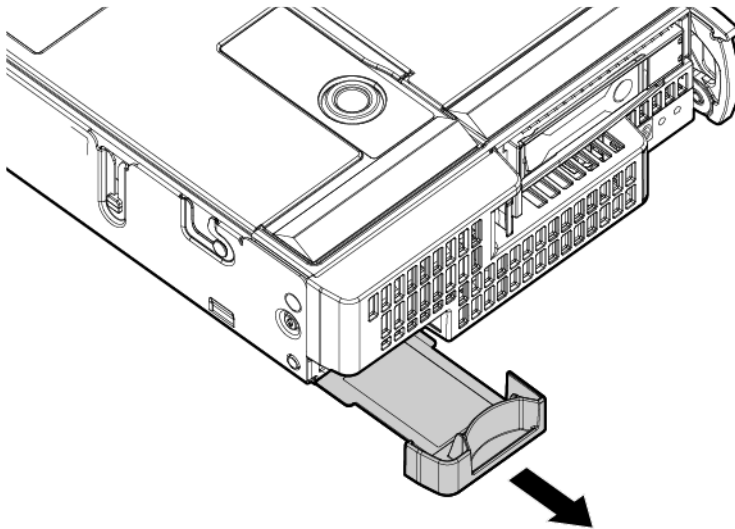

-
- CAUTION:** Always disconnect the drive cable before removing the front panel/drive cage assembly.
-

7. Remove the front panel/drive cage assembly.

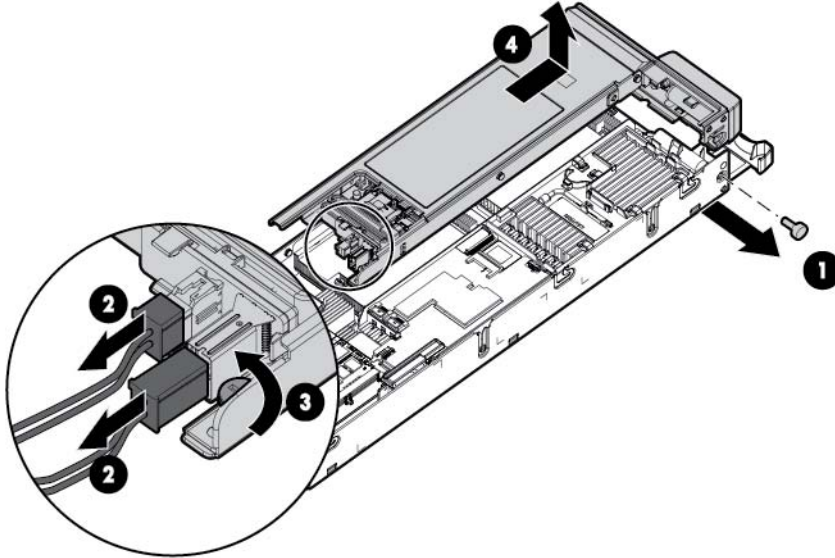

To replace the component, reverse the removal procedure.

Heatsink blank

To remove the component:

1. Power down the server blade (on page 22).
2. Remove the server blade (on page 23).
3. Remove the access panel ("[Access panel](#)" on page 24).



CAUTION: Always disconnect the drive cables from the SAS controller before removing the DIMM baffle. Failure to do so may result in damage to the SAS controller.

4. Disconnect the drive cables from the SAS controller and remove the DIMM baffle ("[DIMM baffle](#)" on page 27).
5. Remove all hard drives ("[Drive](#)" on page 25).
6. Remove the front panel/hard drive cage assembly ("[Front panel/drive cage assembly](#)" on page 39).

7. Remove the heatsink blank.

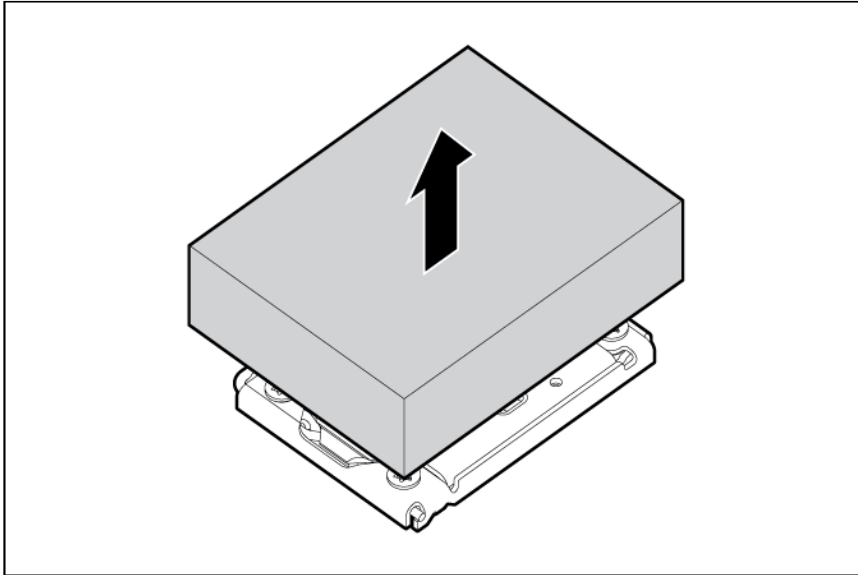

To replace the component, reverse the removal procedure.

Serial label pull tab

To remove the component:

1. Power down the server blade (on page 22).
2. Remove the server blade (on page 23).
3. Remove the access panel ("[Access panel](#)" on page 24).



CAUTION: Always disconnect the drive cables from the SAS controller before removing the DIMM baffle. Failure to do so may result in damage to the SAS controller.

4. Disconnect the drive cables from the SAS controller and remove the DIMM baffle ("[DIMM baffle](#)" on page 27).
5. Remove all hard drives ("[Drive](#)" on page 25).
6. Remove the front panel/drive cage assembly ("[Front panel/drive cage assembly](#)" on page 39).

7. Remove the serial label pull tab.

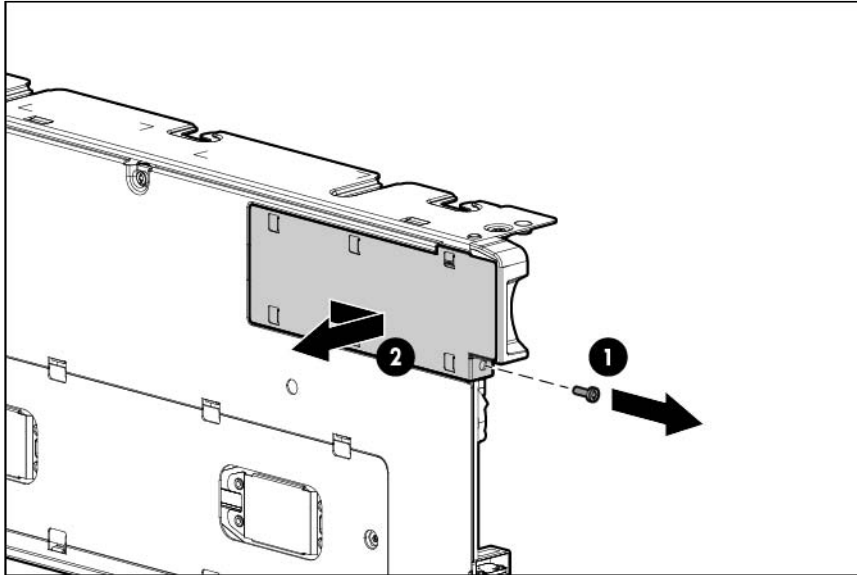

8. Retain the information located on the original serial label pull tab and move it to the replacement serial label pull tab.

To replace the component, reverse the removal procedure.

Heatsink



WARNING: To reduce the risk of personal injury from hot surfaces, allow the drives and the internal system components to cool before touching them.

To remove the component:

1. Power down the server blade (on page 22).
2. Remove the server blade (on page 23).
3. Remove the access panel ("Access panel" on page 24).



CAUTION: Always disconnect the drive cables from the SAS controller before removing the DIMM baffle. Failure to do so may result in damage to the SAS controller.

4. Disconnect the drive cables from the SAS controller and remove the DIMM baffle ("DIMM baffle" on page 27).
5. Remove all hard drives ("Drive" on page 25).
6. Remove the front panel/hard drive cage assembly ("Front panel/drive cage assembly" on page 39).

7. Remove the heatsink.

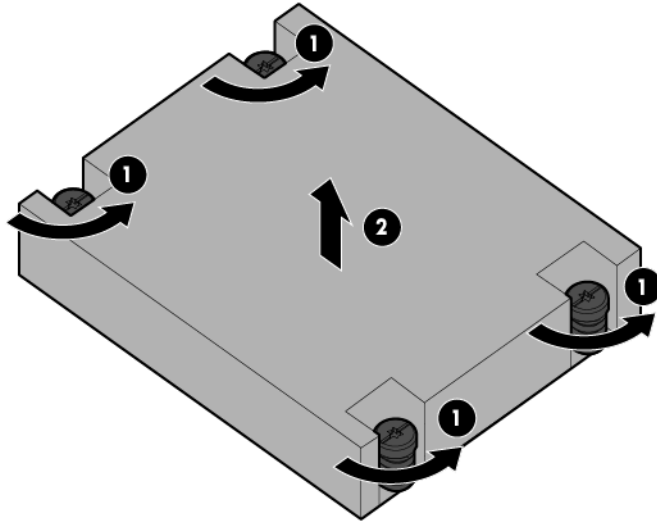

To replace the component:

1. Clean the old thermal grease from the processor with the alcohol swab. Allow the alcohol to evaporate before continuing.
2. Remove the thermal interface protective cover from the heatsink.

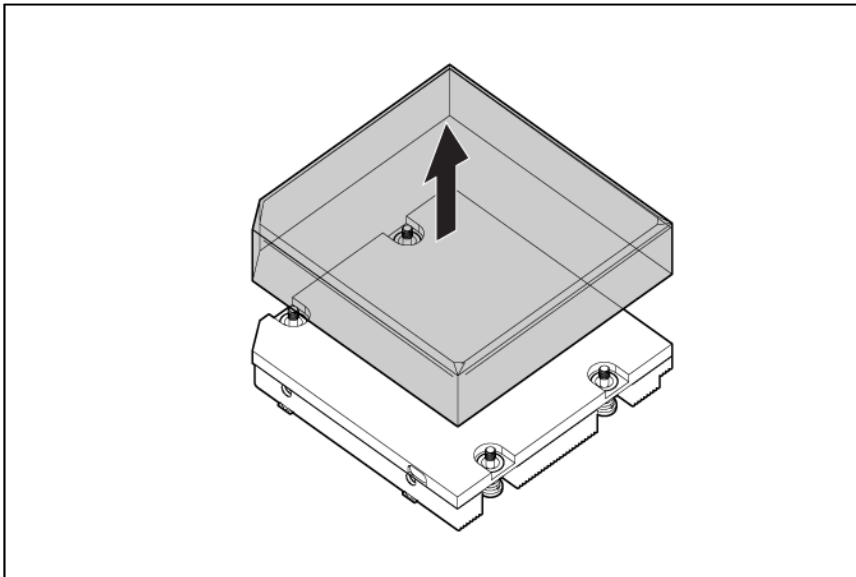

CAUTION: To avoid damage to the system board, processor socket, and screws, do not overtighten the heatsink screws. Use the wrench supplied with the system to reduce the possibility of overtightening the screws.

3. Align and install the heatsink. Alternate tightening the screws until the heatsink is seated properly.

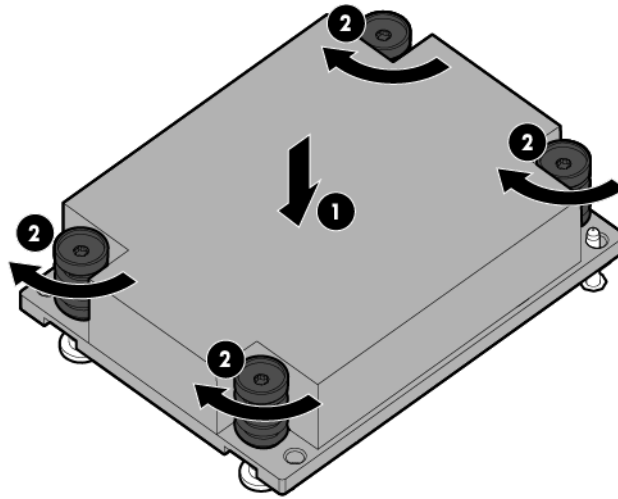

4. Install the DIMM baffle and connect the drive cable to the SAS controller ("[DIMM baffle](#)" on page 27).
5. Install the front panel/drive cage assembly ("[Front panel/drive cage assembly](#)" on page 39).
6. Install all drives ("[Drive](#)" on page 25).
7. Install the access panel ("[Access panel](#)" on page 24).

Processor



WARNING: To reduce the risk of personal injury from hot surfaces, allow the drives and the internal system components to cool before touching them.



CAUTION: To avoid damage to the system board:

- Do not touch the processor socket contacts.
- Always install the processor socket cover after removing the processor from the socket.
- Do not tilt or slide the processor when lowering the processor into the socket.



CAUTION: To avoid damage to the processor:

- Handle the processor only by the edges.
- Do not touch the bottom of the processor, especially the contact area.



CAUTION: To prevent possible server blade overheating, always populate each processor socket with a processor socket cover and a heatsink blank or a processor and a heatsink.



CAUTION: To prevent possible server blade malfunction and damage to the equipment, multiprocessor configurations must contain processors with the same part number.



CAUTION: The heatsink thermal interface media is not reusable and must be replaced if the heatsink is removed from the processor after it has been installed.



IMPORTANT: Processor socket 1 must always be populated. If processor socket 1 is empty, the server blade does not power up.

To remove the component:

1. Power down the server blade (on page 22).
2. Remove the server blade (on page 23).
3. Remove the access panel ("Access panel" on page 24).



CAUTION: Always disconnect the drive cables from the SAS controller before removing the DIMM baffle. Failure to do so may result in damage to the SAS controller.

4. Disconnect the drive cables from the SAS controller and remove the DIMM baffle ("DIMM baffle" on page 27).
5. Remove all hard drives ("Drive" on page 25).
6. Remove the front panel/drive cage assembly ("Front panel/drive cage assembly" on page 39).
7. Remove the heatsink ("Heatsink" on page 42).
8. Open the processor socket retaining bracket and the processor locking lever.

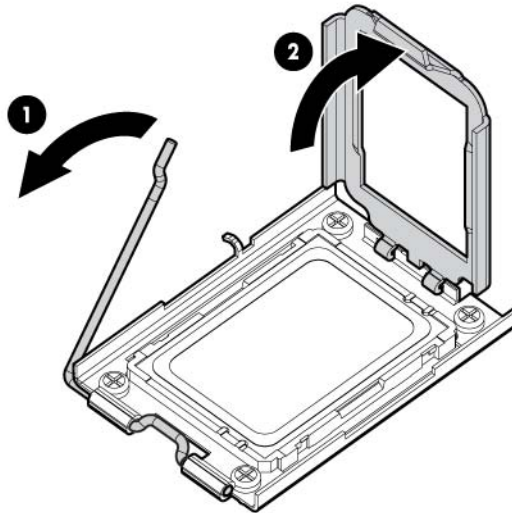

9. Using the processor tool, remove the processor from the system board.

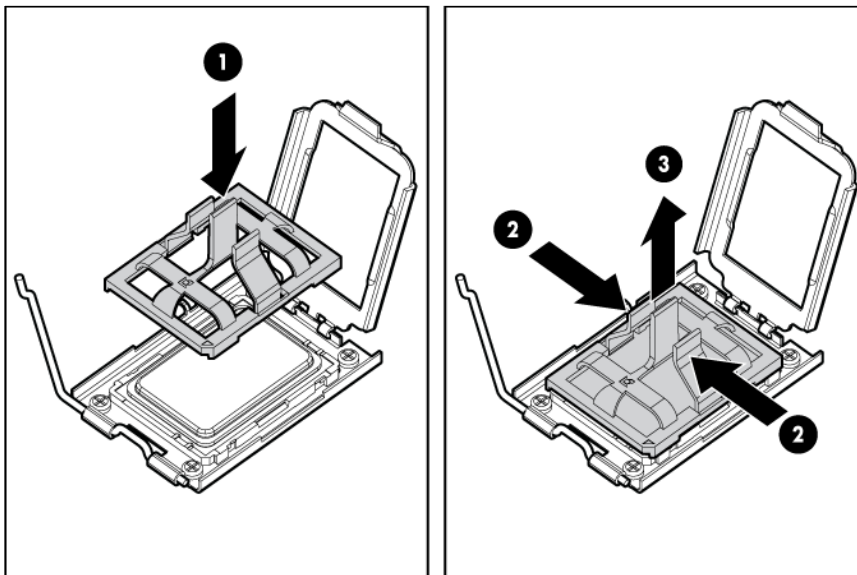



CAUTION: To avoid damage to the processor, do not touch the bottom of the processor, especially the contact area.

To replace the component:



IMPORTANT: Be sure the processor remains inside the processor installation tool.

1. If the processor has separated from the installation tool, carefully re-insert the processor in the tool. Handle the processor by the edges only, and do not touch the bottom of the processor, especially the contact area.

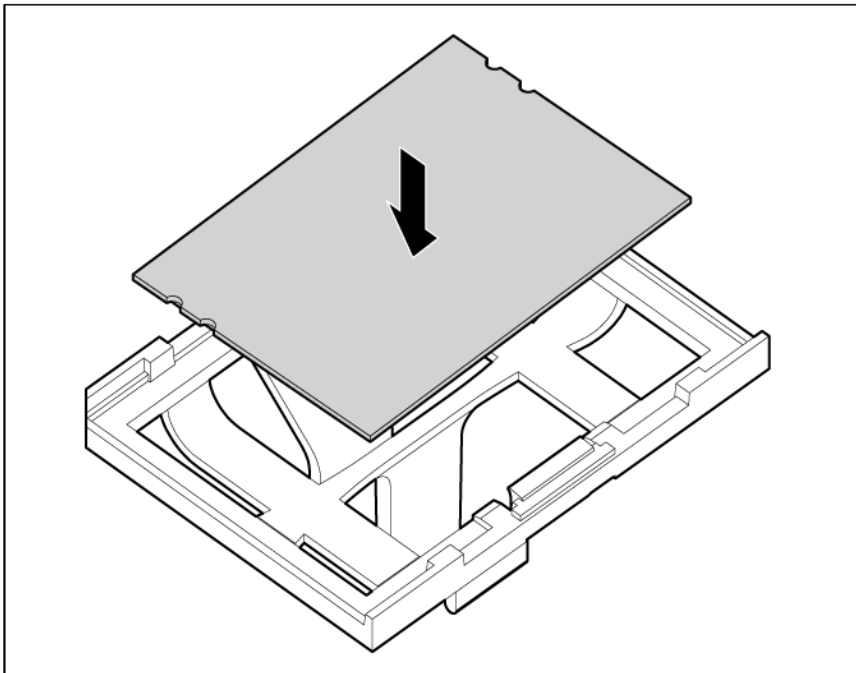

2. The processor fits one way into the socket. Use the alignment guides on the processor and socket to properly align the processor with the socket. Install the spare processor. **THE PINS ON THE SYSTEM BOARD ARE VERY FRAGILE AND EASILY DAMAGED.**

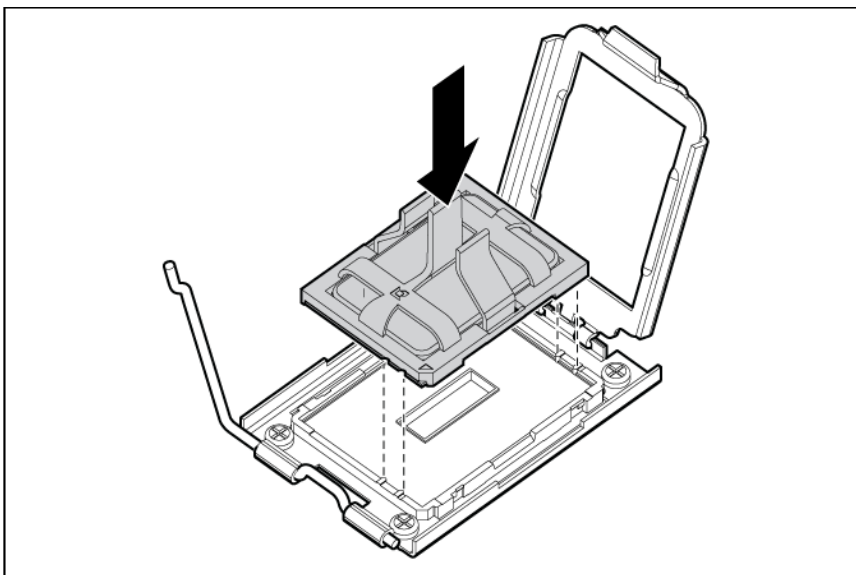



CAUTION: THE PINS ON THE SYSTEM BOARD ARE VERY FRAGILE AND EASILY DAMAGED. To avoid damage to the system board:

- Never install or remove a processor without using the processor installation tool.
- Do not touch the processor socket contacts.
- Do not tilt or slide the processor when lowering the processor into the socket.

3. Press the tabs on the processor tool to release the processor, and then remove the processor tool.

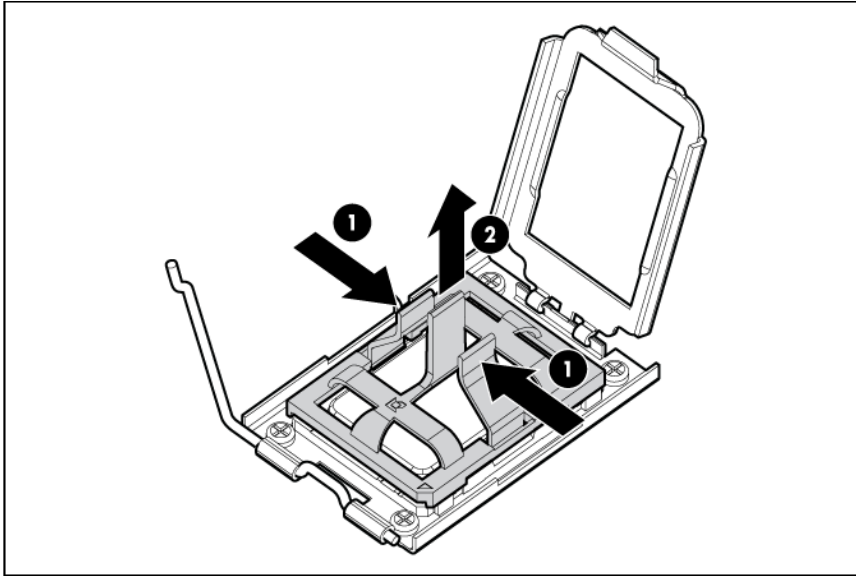

4. Close the processor socket retaining bracket and the processor locking lever.



CAUTION: Be sure to close the processor socket retaining bracket before closing the processor locking lever. The lever should close without resistance. Forcing the lever closed can damage the processor and socket, requiring system board replacement.

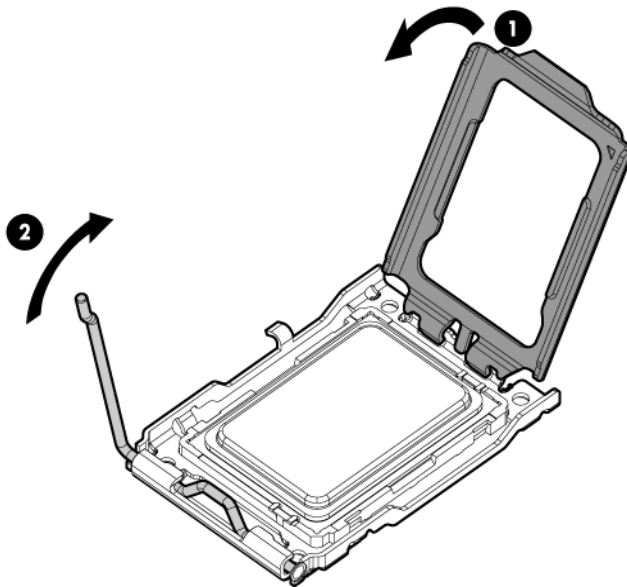

5. Clean the old thermal grease from the heatsink with the alcohol swab. Allow the alcohol to evaporate before continuing.

6. Apply all the grease to the top of the processor in the following pattern to ensure even distribution.

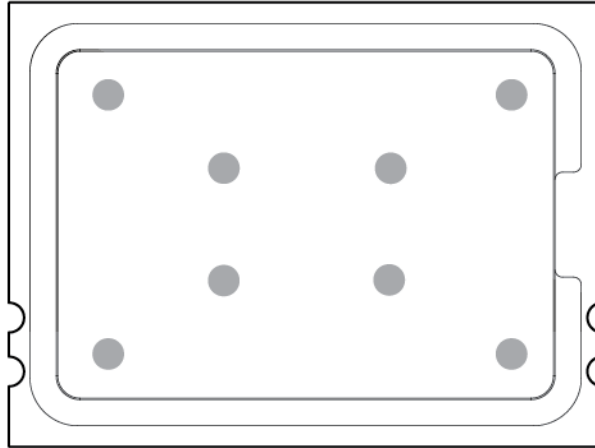

7. Align and install the heatsink. Alternate tightening the screws until the heatsink is seated properly.

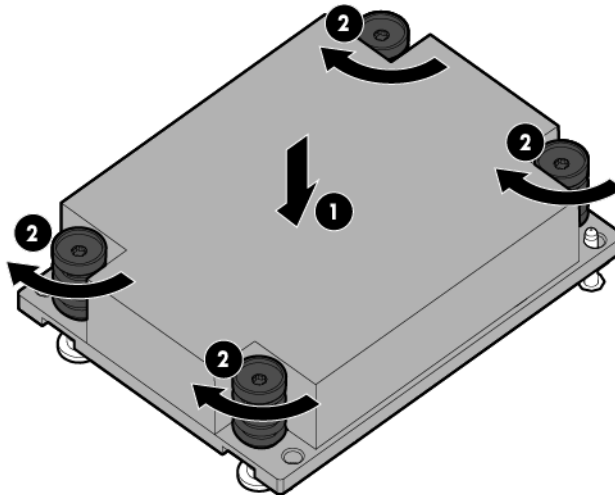

8. Install the front panel/drive cage assembly ("[Front panel/drive cage assembly](#)" on page 39).
9. Install the DIMM baffle and connect the drive cable to the SAS controller ("[DIMM baffle](#)" on page 27).
10. Install all drives ("[Drive](#)" on page 25).
11. Install the access panel ("[Access panel](#)" on page 24).
12. Install the server blade.

System battery

If the server blade no longer automatically displays the correct date and time, you might have to replace the battery that provides power to the real-time clock. Under normal use, battery life is 5 to 10 years.



WARNING: The computer contains an internal lithium manganese dioxide, a vanadium pentoxide, or an alkaline battery pack. A risk of fire and burns exists if the battery pack is not properly handled. To reduce the risk of personal injury:

- Do not attempt to recharge the battery.
 - Do not expose the battery to temperatures higher than 60°C (140°F).
 - Do not disassemble, crush, puncture, short external contacts, or dispose of in fire or water.
 - Replace only with the spare designated for this product.
-

To remove the component:

1. Power down the server blade (on page 22).
2. Remove the server blade (on page 23).
3. Access the internal server components ("Server blade preparation" on page 22).
4. Identify the battery location ("System board components" on page 71).
5. Remove the system battery.

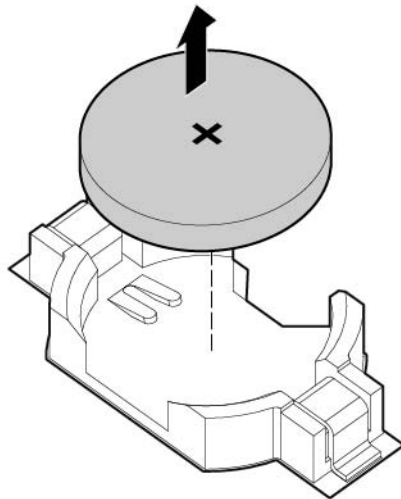

IMPORTANT: Replacing the system board battery resets the system ROM to its default configuration. After replacing the battery, reconfigure the system through RBSU.

To replace the component, reverse the removal procedure.

System board



CAUTION: When returning a damaged system board to HP, always install all processor socket covers to prevent damage to the processor sockets and system board.

To remove the component:

1. Power down the server blade (on page 22).
2. Remove the server blade (on page 23).
3. Remove the access panel ("Access panel" on page 24).
4. Remove all hard drive blanks ("Drive blank" on page 25).

5. Remove all hard drives ("[Drive](#)" on page [25](#)).



CAUTION: Always disconnect the drive cables from the SAS controller before removing the DIMM baffle. Failure to do so may result in damage to the SAS controller.

6. Disconnect the drive cables from the SAS controller and remove the DIMM baffle ("[DIMM baffle](#)" on page [27](#)).
7. Remove all DIMMs ("[DIMMs](#)" on page [28](#)).
8. Disconnect the mezzanine option capacitor pack cable, if installed ("[Capacitor pack cabling](#)" on page [64](#)).
9. Remove the mezzanine option capacitor pack, if installed ("[Removing the mezzanine option capacitor pack](#)" on page [37](#)).
10. Remove the front panel/drive cage assembly ("[Front panel/drive cage assembly](#)" on page [39](#)).
11. Remove the mezzanine assembly ("[Mezzanine assembly](#)" on page [29](#)).
12. Remove the FlexibleLOM ("[FlexibleLOM](#)" on page [32](#)).
13. Remove the heatsink ("[Heatsink](#)" on page [42](#)).
14. Open the processor socket retaining bracket and the processor locking lever.

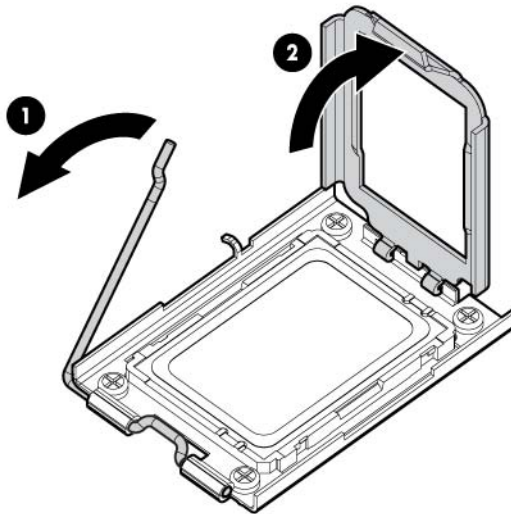

15. Using the processor tool, remove the processor from the system board.

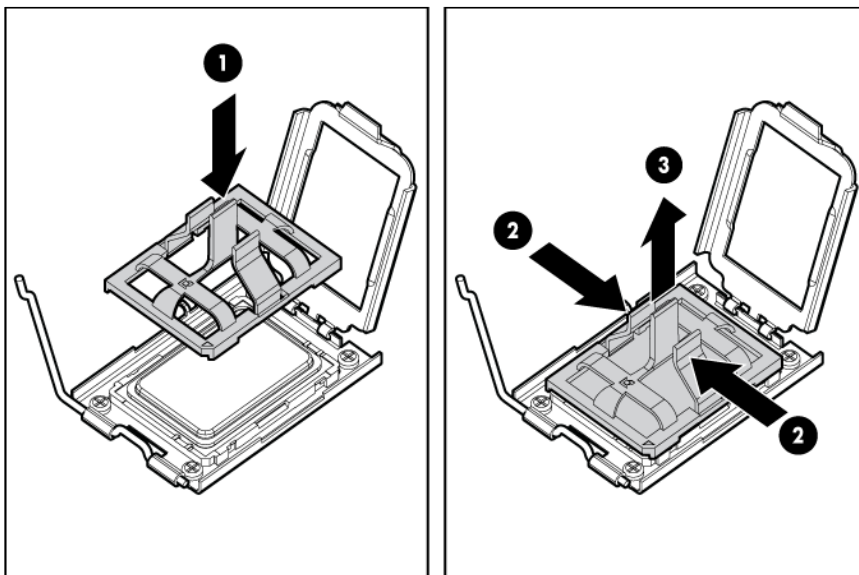

CAUTION: To avoid damage to the processor, do not touch the bottom of the processor, especially the contact area.

16. Install the processor socket protective cover in each processor socket.
17. Remove the serial label pull tab.

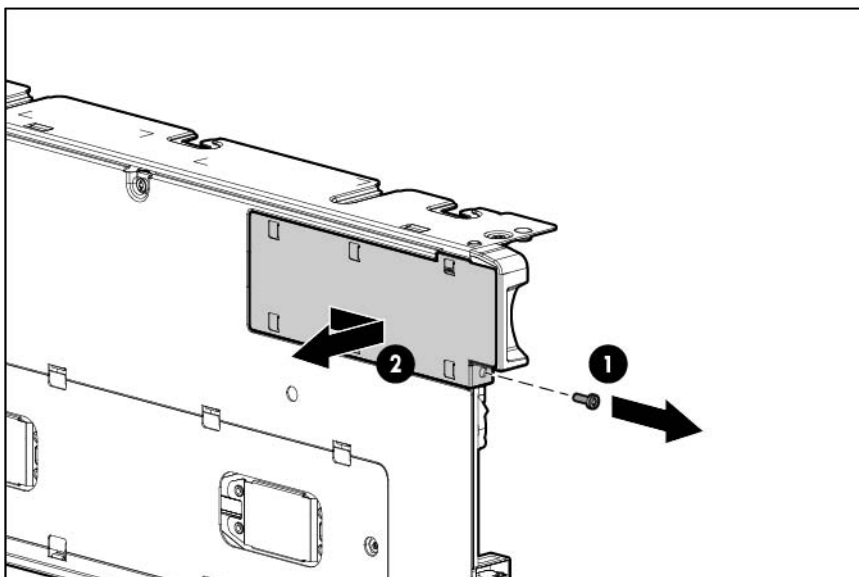

To replace the system board:

1. Install the serial label pull tab.

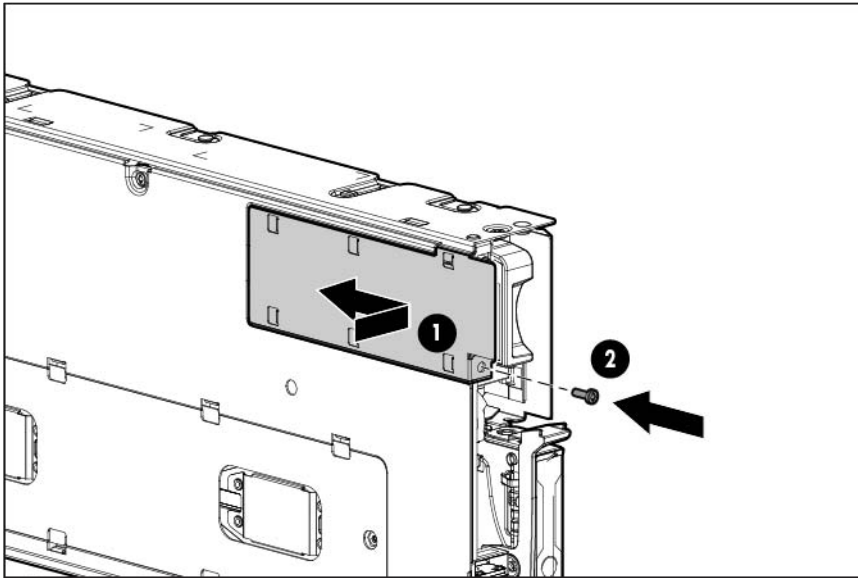

2. Remove the processor socket protective cover.

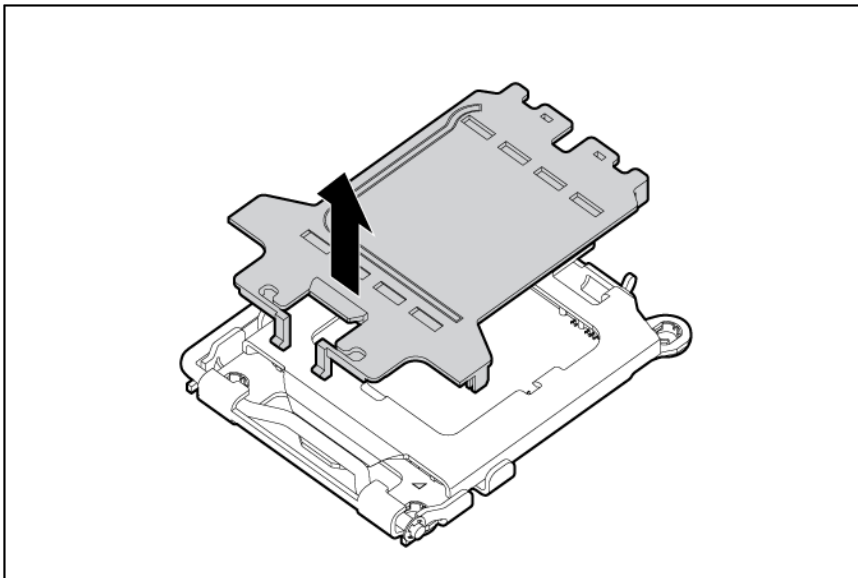

3. Install the processor socket cover onto the processor socket of the failed system board.



IMPORTANT: Be sure the processor remains inside the processor installation tool.

4. If the processor has separated from the installation tool, carefully re-insert the processor in the tool. Handle the processor by the edges only, and do not touch the bottom of the processor, especially the contact area.

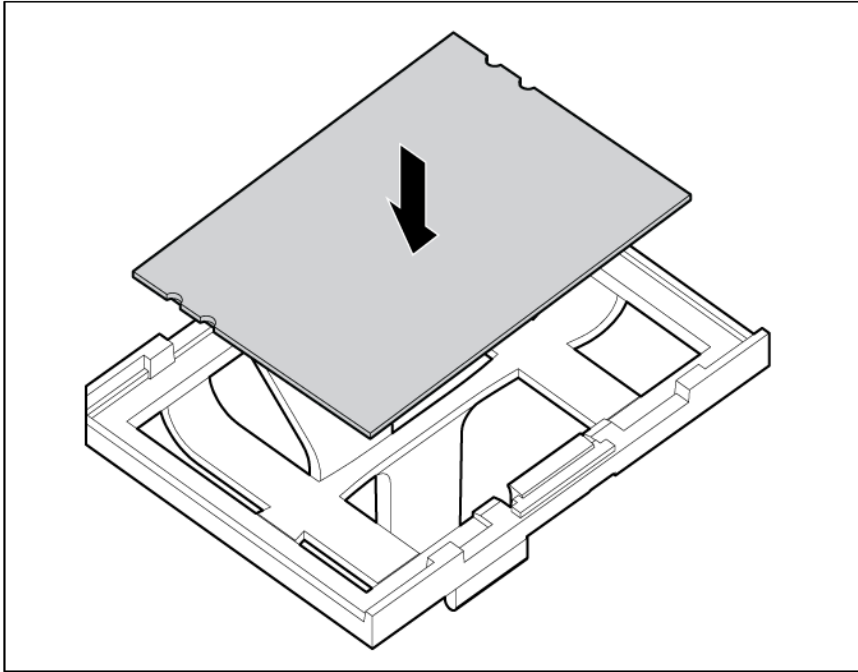

5. The processor fits one way into the socket. Use the alignment guides on the processor and socket to properly align the processor with the socket. Install the processor on the spare system board. **THE PINS ON THE SYSTEM BOARD ARE VERY FRAGILE AND EASILY DAMAGED.**

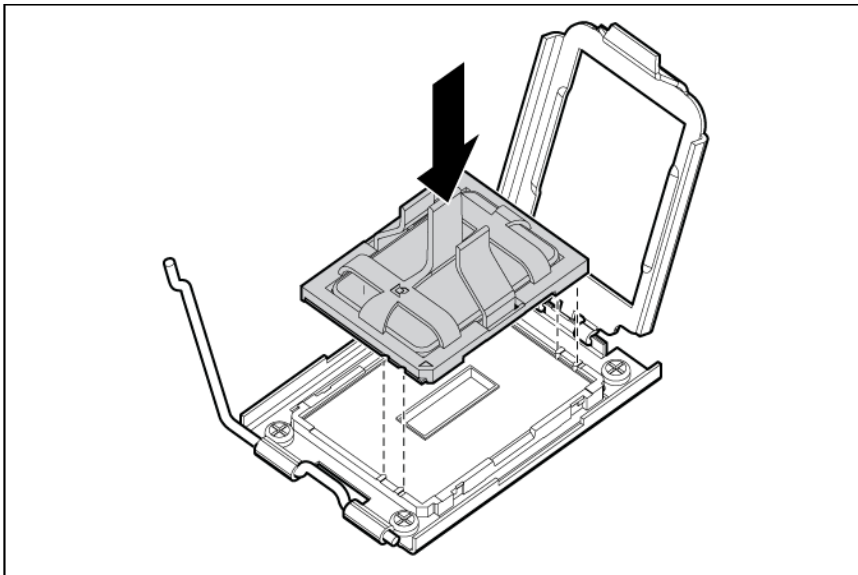

CAUTION: THE PINS ON THE SYSTEM BOARD ARE VERY FRAGILE AND EASILY DAMAGED. To avoid damage to the system board:

- Never install or remove a processor without using the processor installation tool.
- Do not touch the processor socket contacts.
- Do not tilt or slide the processor when lowering the processor into the socket.

6. Press the tabs on the processor tool to release the processor, and then remove the processor tool.

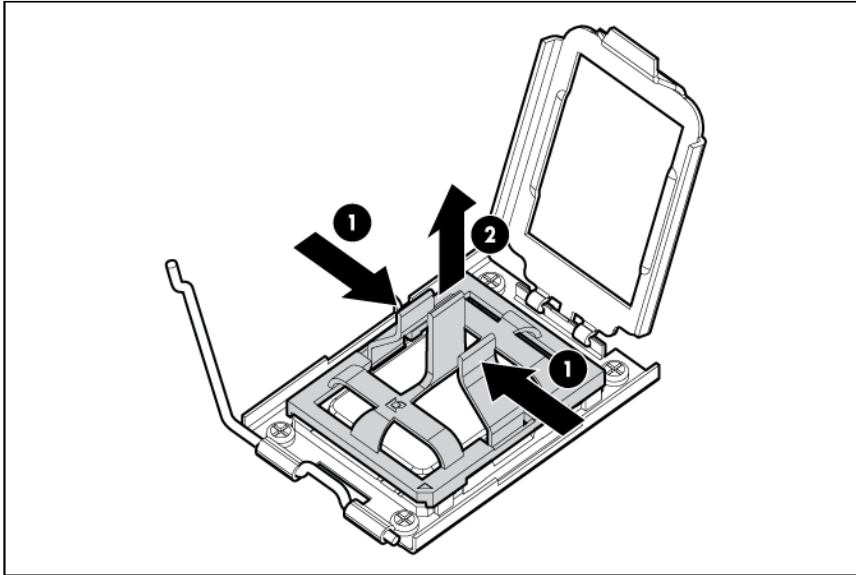

7. Close the processor socket retaining bracket and the processor locking lever.



CAUTION: Be sure to close the processor socket retaining bracket before closing the processor locking lever. The lever should close without resistance. Forcing the lever closed can damage the processor and socket, requiring system board replacement.

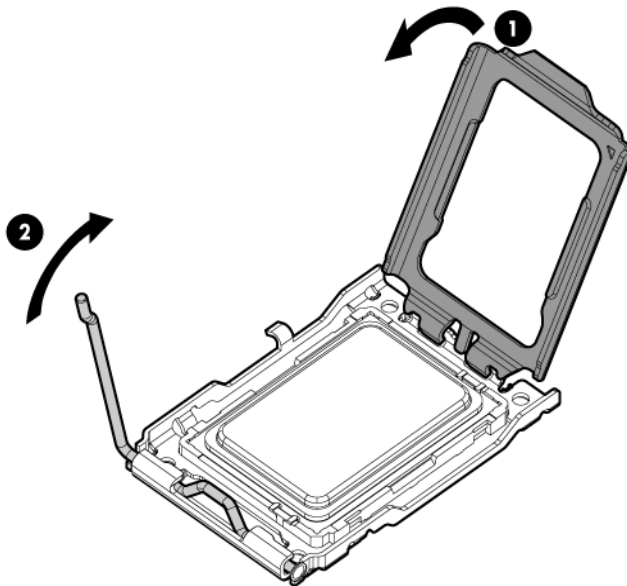

8. Clean the old thermal grease from the heatsink and the top of the processor with the alcohol swab. Allow the alcohol to evaporate before continuing.
9. Apply all the grease to the top of the processor in the following pattern to ensure even distribution.



CAUTION: The heatsink thermal interface media is not reusable and must be replaced if the heatsink is removed from the processor after it has been installed.

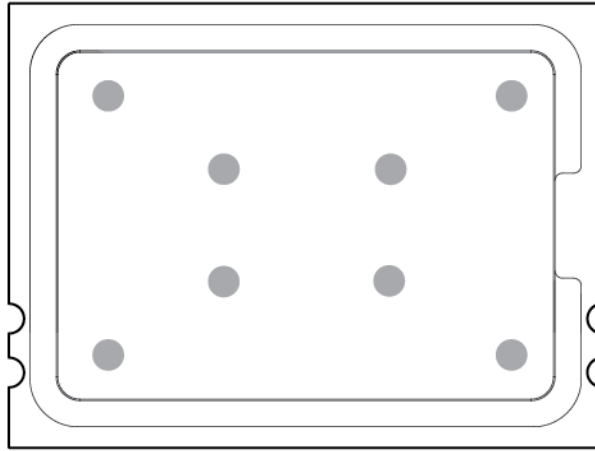

10. Install the heatsink ("[Heatsink](#)" on page 42).



IMPORTANT: Install all components with the same configuration that was used on the failed system board.

11. Install all components removed from the failed system board.
12. Install the front panel/hard drive cage assembly ("[Front panel/drive cage assembly](#)" on page 39).
13. Install all drives ("[Drive](#)" on page 25).



IMPORTANT: To avoid damage to the server blade, support the riser board when installing the TPM board and rivet.

14. If necessary, install the TPM module. For more information, see the *HP ProLiant BL465c Gen8 Server Blade User Guide*.
15. Install the access panel ("[Access panel](#)" on page 24).

After you replace the system board, you must re-enter the server blade serial number and the product ID.

1. During the server blade startup sequence, press the **F9** key to access RBSU.
2. Select the **Advanced Options** menu.
3. Select **Service Options**.
4. Select **Serial Number**. The following warning appears:
Warning: The serial number should ONLY be modified by qualified service personnel. This value should always match the serial number located on the chassis.
5. Press the **Enter** key to clear the warning.
6. Enter the serial number and press the **Enter** key.
7. Select **Product ID**. The following warning appears:
Warning: The Product ID should ONLY be modified by qualified service personnel. This value should always match the Product ID located on the chassis.
8. Enter the product ID and press the **Enter** key.
9. Press the **Esc** key to close the menu.
10. Press the **Esc** key to exit RBSU.

11. Press the **F10** key to confirm exiting RBSU. The server blade automatically reboots.

Server blade release lever assembly

To remove the component:

1. Power down the server blade (on page 22).
2. Remove the server blade (on page 23).
3. Remove the access panel ("[Access panel](#)" on page 24).
4. Remove all hard drives ("[Drive](#)" on page 25).

CAUTION: Always disconnect the drive cables from the SAS controller before removing the DIMM baffle. Failure to do so may result in damage to the SAS controller.

5. Disconnect the drive cables from the SAS controller and remove the DIMM baffle ("[DIMM baffle](#)" on page 27).
6. Remove all DIMMs ("[DIMMs](#)" on page 28).
7. If a capacitor pack is installed and connected to a mezzanine option, disconnect the cable from the mezzanine option and remove the capacitor pack ("[Removing the mezzanine option capacitor pack](#)" on page 37).
8. Remove the heatsink blank, if installed ("[Heatsink blank](#)" on page 40).
9. Remove the front panel/drive cage assembly ("[Front panel/drive cage assembly](#)" on page 39).
10. While holding the system board in place, turn the base pan on its side and remove the four system board screws from the bottom of the base pan.

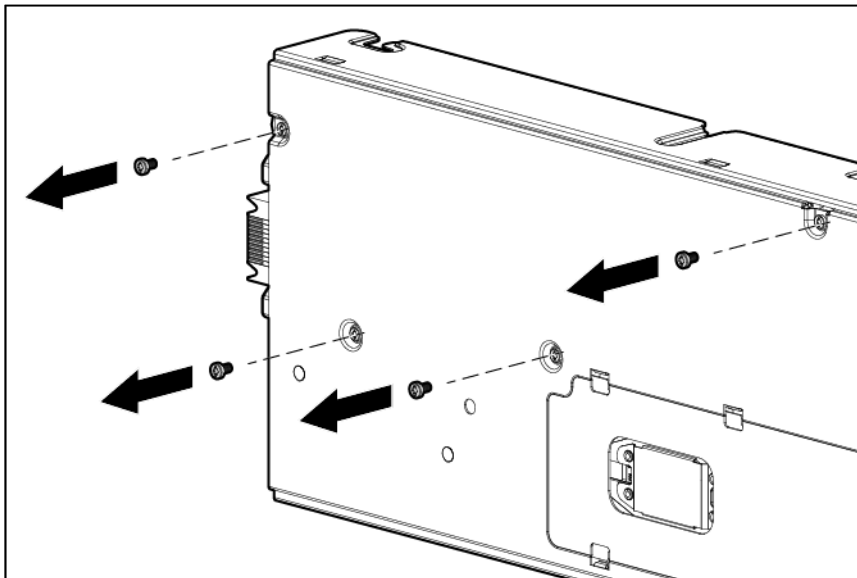

11. Place the server blade on a flat, level work surface.

- Slide the system board approximately 1.27 cm (0.50 inches) towards the rear of the server, and then lift the system board from the base pan.

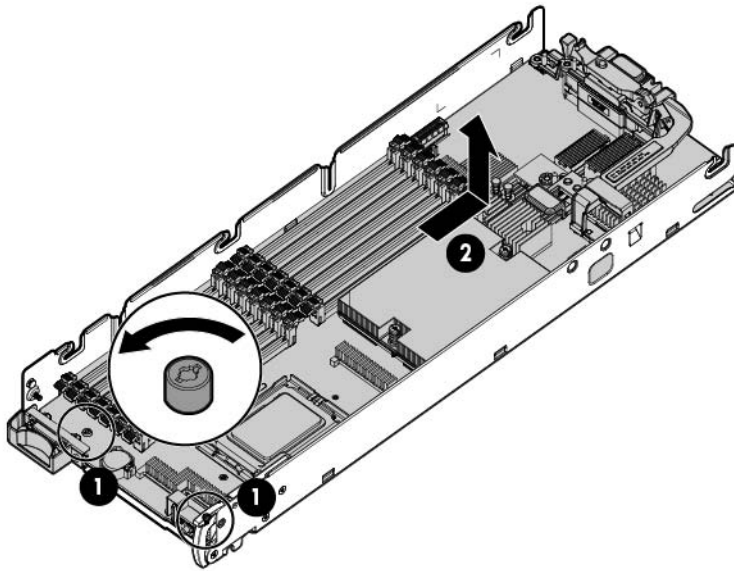

- Remove the three T-10 screws from the outside of the base pan, and then remove the server blade release lever bracket.
- Remove the T-10 screw from the inside of the base pan and then remove the server blade release lever assembly.

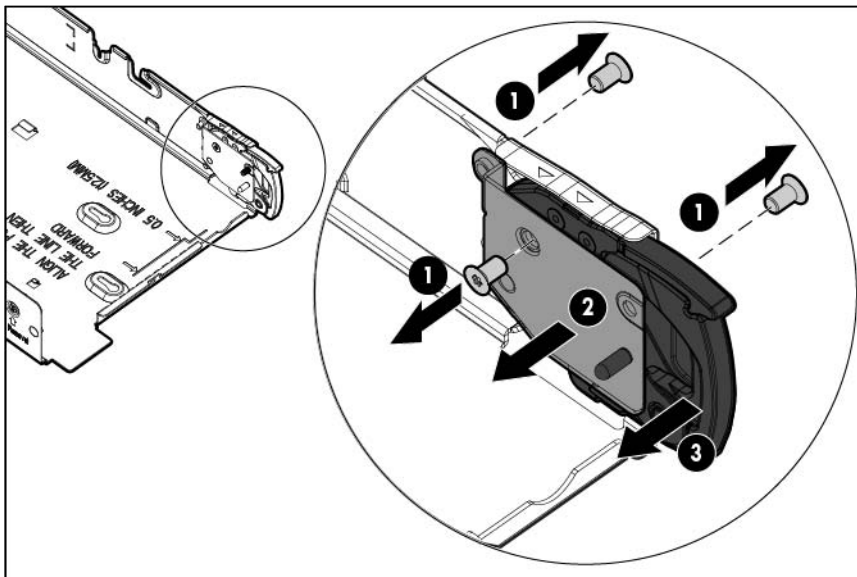

To replace the component:

- Install the server blade release lever assembly, and then install the T-10 screws from the outside of the base pan.

2. Install the server blade release lever bracket, and then install the T-10 screw from the inside of the base pan.

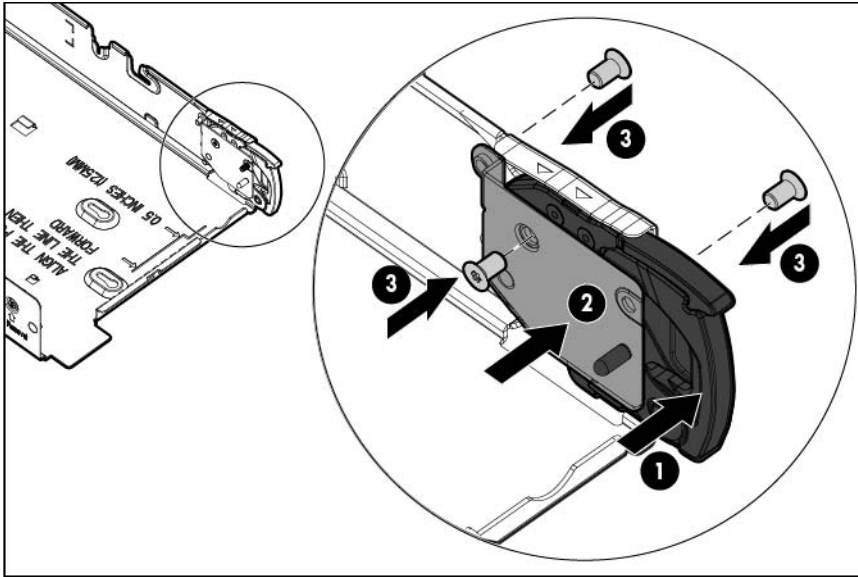

3. Align the system board, and then slide it into place inside the base pan.

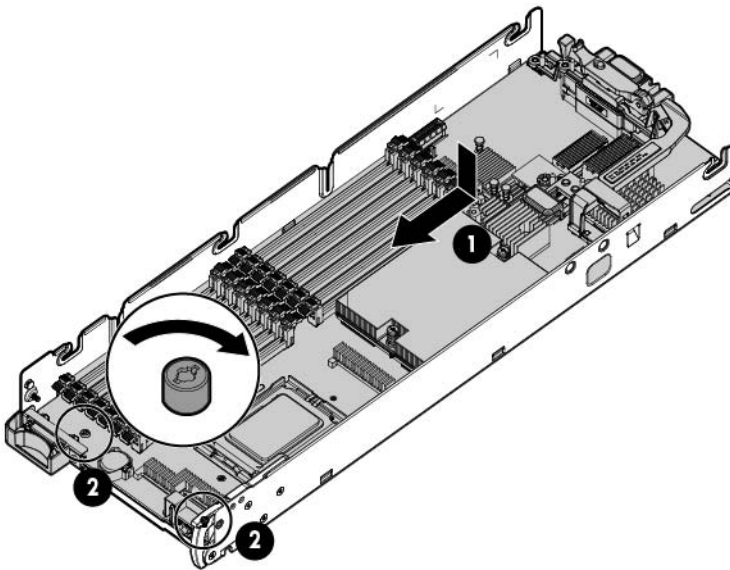

4. While holding the system board in place, turn the base pan on the side and install the four screws on the bottom of the base pan.

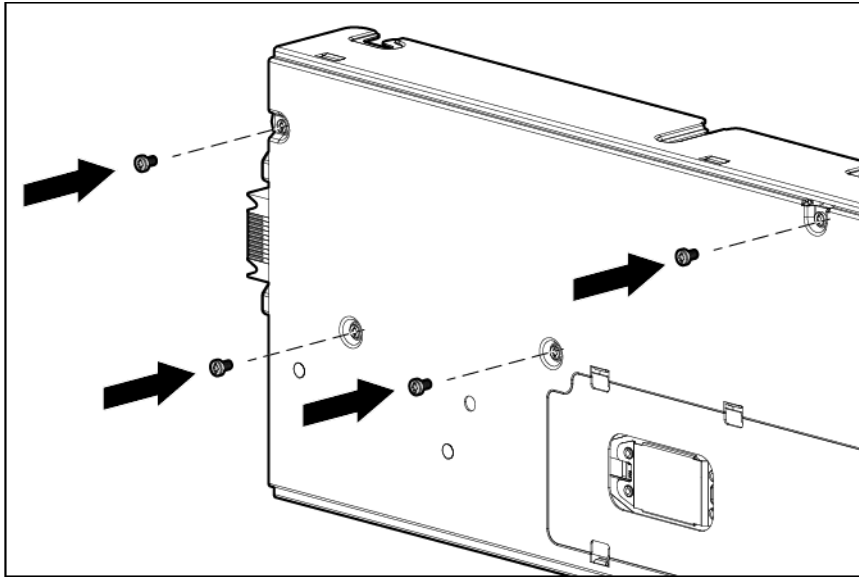

5. Place the server blade on a flat, level work surface.



IMPORTANT: Install all components in the same configuration prior to removing the system board.

6. Install the heatsink blank ("[Heatsink blank](#)" on page 40).
7. If a capacitor pack option is installed and cabled to a mezzanine option, install this capacitor pack and route the cable to the mezzanine option. For more information on routing the cables, see "[FBWC capacitor pack cabling](#)" (["Capacitor pack cabling"](#) on page 64)."
8. Install all DIMMs ("[DIMMs](#)" on page 28).
9. Install the DIMM baffle and connect the drive cable to the SAS controller ("[DIMM baffle](#)" on page 27).
10. Install the front panel/drive cage assembly ("[Front panel/drive cage assembly](#)" on page 39).
11. Install the hard drives ("[Drive](#)" on page 25).
12. Install the hard drive blanks ("[Drive blank](#)" on page 25).
13. Install the access panel ("[Access panel](#)" on page 24).

HP Trusted Platform Module

The TPM is not a customer-removable part.



CAUTION: Any attempt to remove an installed TPM from the system board breaks or disfigures the TPM security rivet. Upon locating a broken or disfigured rivet on an installed TPM, administrators should consider the system compromised and take appropriate measures to ensure the integrity of the system data.

If you suspect a TPM board failure, leave the TPM installed and remove the system board ("[System board](#)" on page 49). Contact an HP authorized service provider for a replacement system board and TPM board.

Diagnostic tools

HP product QuickSpecs

For more information about product features, specifications, options, configurations, and compatibility, see the product QuickSpecs on the HP Product Bulletin website (<http://www.hp.com/go/productbulletin>).

HP ROM-Based Setup Utility

RBSU is a configuration utility embedded in HP ProLiant servers that performs a wide range of configuration activities that can include the following:

- Configuring system devices and installed options
- Enabling and disabling system features
- Displaying system information
- Selecting the primary boot controller
- Configuring memory options
- Language selection

For more information on RBSU, see the *HP ROM-Based Setup Utility User Guide* on the Documentation CD or the HP website (<http://www.hp.com/support/rbsu>).

Using RBSU

To use RBSU, use the following keys:

- To access RBSU, press the **F9** key during power-up when prompted.
- To navigate the menu system, use the arrow keys.
- To make selections, press the **Enter** key.
- To access Help for a highlighted configuration option, press the **F1** key.



IMPORTANT: RBSU automatically saves settings when you press the **Enter** key. The utility does not prompt you for confirmation of settings before you exit the utility. To change a selected setting, you must select a different setting and press the **Enter** key.

Default configuration settings are applied to the server at one of the following times:

- Upon the first system power-up
- After defaults have been restored

Default configuration settings are sufficient for proper typical server operation, but configuration settings can be modified using RBSU. The system will prompt you for access to RBSU with each power-up.

HP Insight Diagnostics

HP Insight Diagnostics is a proactive server blade management tool, available in both offline and online versions, that provides diagnostics and troubleshooting capabilities to assist IT administrators who verify server blade installations, troubleshoot problems, and perform repair validation.

HP Insight Diagnostics Offline Edition performs various in-depth system and component testing while the OS is not running. To run this utility, boot the server blade using Intelligent Provisioning.

HP Insight Diagnostics Online Edition is a web-based application that captures system configuration and other related data needed for effective server blade management. Available in Microsoft Windows and Linux versions, the utility helps to ensure proper system operation.

For more information or to download the utility, see the HP website (<http://www.hp.com/servers/diags>). HP Insight Diagnostics Online Edition is also available in the SPP. For more information, see the HP website (<http://www.hp.com/go/spp/download>).

HP Insight Diagnostics survey functionality

HP Insight Diagnostics (on page 61) provides survey functionality that gathers critical hardware and software information on ProLiant server blades.

This functionality supports operating systems that are supported by the server blade. For operating systems supported by the server blade, see the HP website (<http://www.hp.com/go/supportos>).

If a significant change occurs between data-gathering intervals, the survey function marks the previous information and overwrites the survey data files to reflect the latest changes in the configuration.

Survey functionality is installed with every Intelligent Provisioning-assisted HP Insight Diagnostics installation, or it can be installed through the SPP.

Active Health System

HP Active Health System provides the following features:

- Combined diagnostics tools/scanners
- Always on, continuous monitoring for increased stability and shorter downtimes
- Rich configuration history
- Health and service alerts
- Easy export and upload to Service and Support

The HP Active Health System monitors and records changes in the server hardware and system configuration. The Active Health System assists in diagnosing problems and delivering rapid resolution when server failures occur.

The Active Health System collects the following types of data:

- Server model
- Serial number
- Processor model and speed
- Storage capacity and speed

- Memory capacity and speed
- Firmware/BIOS

HP Active Health System does not collect information about Active Health System users' operations, finances, customers, employees, partners, or data center, such as IP addresses, host names, user names, and passwords. HP Active Health System does not parse or change operating system data from third-party error event log activities, such as content created or passed through by the operating system.

The data that is collected is managed according to the HP Data Privacy policy. For more information see the HP website (<http://www.hp.com/go/privacy>).

The Active Health System log, in conjunction with the system monitoring provided by Agentless Management or SNMP Pass-thru, provides continuous monitoring of hardware and configuration changes, system status, and service alerts for various server components.

The Agentless Management Service is available in the SPP, which is a disk image (.iso) that you can download from the HP website (<http://www.hp.com/go/spp/download>). The Active Health System log can be downloaded manually from HP iLO or HP Intelligent Provisioning and sent to HP. For more information, see the *HP iLO User Guide* or *HP Intelligent Provisioning User Guide* on the HP website (<http://www.hp.com/go/ilo/docs>).

Integrated Management Log

The IML records hundreds of events and stores them in an easy-to-view form. The IML timestamps each event with 1-minute granularity.

You can view recorded events in the IML in several ways, including the following:

- From within HP SIM
- From within operating system-specific IML viewers
 - For Windows: IML Viewer
 - For Linux: IML Viewer Application
- From within the HP iLO user interface
- From within HP Insight Diagnostics (on page 61)

USB support

HP provides both standard USB 2.0 support and legacy USB 2.0 support. Standard support is provided by the OS through the appropriate USB device drivers. Before the OS loads, HP provides support for USB devices through legacy USB support, which is enabled by default in the system ROM.

Legacy USB support provides USB functionality in environments where USB support is not available normally. Specifically, HP provides legacy USB functionality for the following:

- POST
- RBSU
- Diagnostics
- DOS
- Operating environments which do not provide native USB support

Internal USB functionality

An internal USB connector is available for use with security key devices and USB drive keys. This solution provides for use of a permanent USB key installed in the internal connector, avoiding issues of clearance on the front of the rack and physical access to secure data.

External USB functionality

HP provides external USB support to enable local connection of USB devices for server blade administration, configuration, and diagnostic procedures. For more information, see "Using the HP c-Class Blade SUV Cable (on page 65)."

For additional security, external USB functionality can be disabled through RBSU. Disabling external USB support in RBSU disables the USB connectors on the HP c-Class Blade SUV Cable.

Cabling

Cabling resources

Cabling configurations and requirements vary depending on the product and installed options. For more information about product features, specifications, options, configurations, and compatibility, see the product QuickSpecs on the HP Product Bulletin website (<http://www.hp.com/go/productbulletin>).

Capacitor pack cabling

- FBWC capacitor pack cabling for the SAS controller

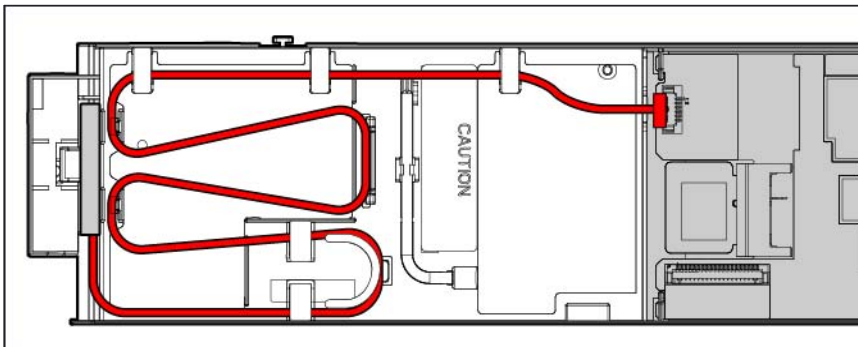

- FBWC capacitor pack cabling for the mezzanine option

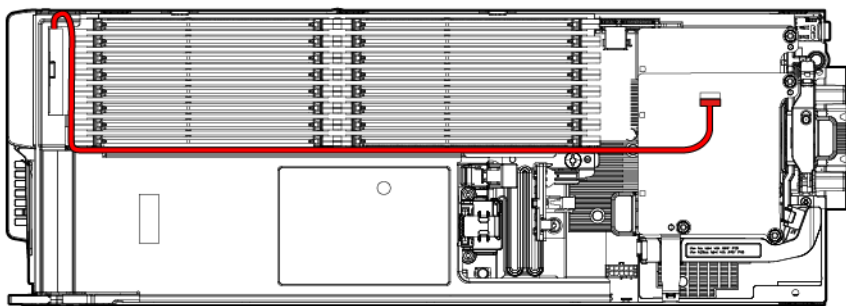

For capacitor pack and cabling instructions, see "FBWC procedures (on page 36)."

Drive cabling

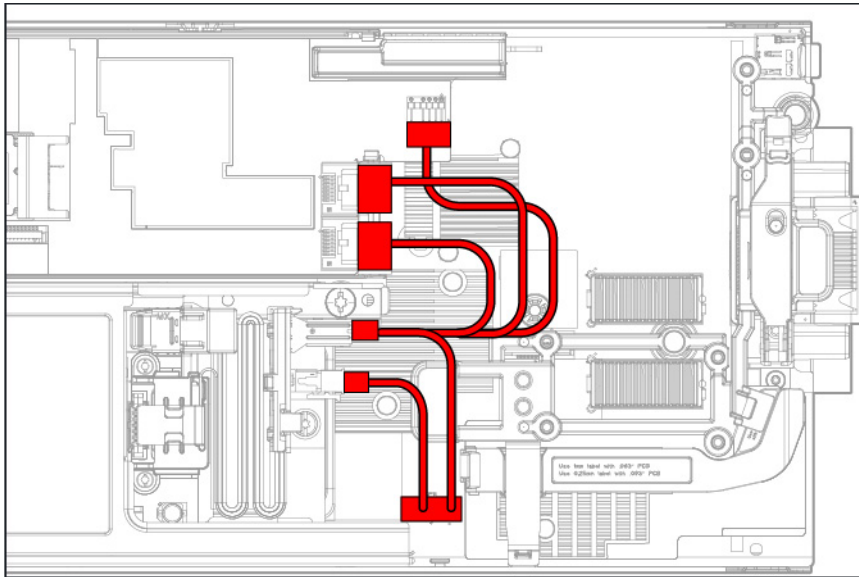

Using the HP c-Class Blade SUV Cable

The HP c-Class Blade SUV Cable enables the user to perform server blade administration, configuration, and diagnostic procedures by connecting video and USB devices directly to the server blade. For SUV cable connectors, see "HP c-Class Blade SUV Cable (on page 75)."

Connecting locally to a server blade with video and USB devices

Use the SUV cable to connect a monitor and any of the following USB devices:

- USB hub
- USB keyboard
- USB mouse
- USB CD/DVD-ROM drive

Numerous configurations are possible. This section offers two possible configurations. For more information, see "USB support (on page 62)."

Accessing a server blade with local KVM

For this configuration, a USB hub is not necessary. To connect additional devices, use a USB hub.

CAUTION: Before disconnecting the SUV cable from the connector, always squeeze the release buttons on the sides of the connector. Failure to do so can result in damage to the equipment.

1. Open the serial label pull tab and connect the HP c-Class Blade SUV Cable to the server blade.
2. Connect the video connector to a monitor.

3. Connect a USB mouse to one USB connector.
4. Connect a USB keyboard to the second USB connector.

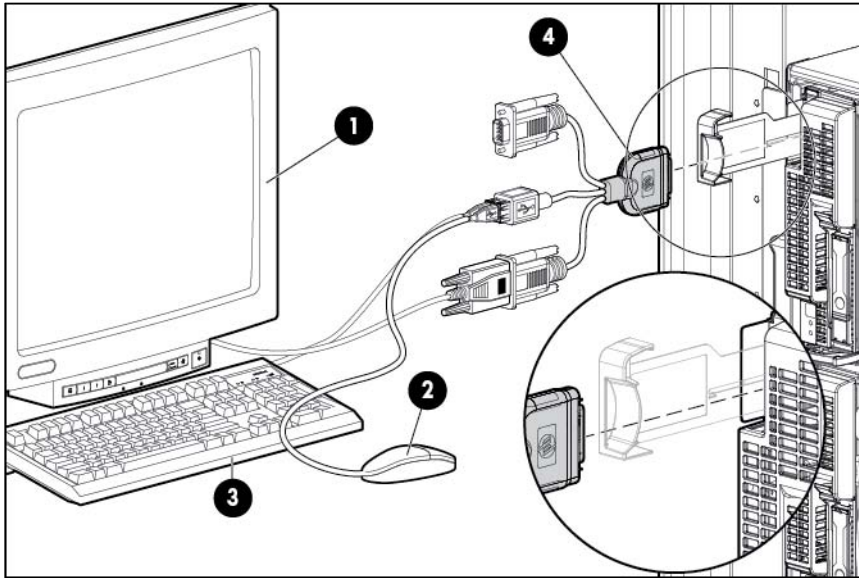

Item	Description
1	Monitor
2	USB mouse
3	USB keyboard
4	HP c-Class Blade SUV Cable

Accessing local media devices

Use the following configuration when configuring a server blade or loading software updates and patches from a USB CD/DVD-ROM.

Use a USB hub when connecting a USB CD-ROM drive to the server blade. The USB hub provides additional connections.

1. Open the serial label pull tab and connect the HP c-Class Blade SUV cable to the server blade.
2. Connect the video connector to a monitor.
3. Connect a USB hub to one USB connector.
4. Connect the following to the USB hub:
 - o USB CD/DVD-ROM drive
 - o USB keyboard

- USB mouse

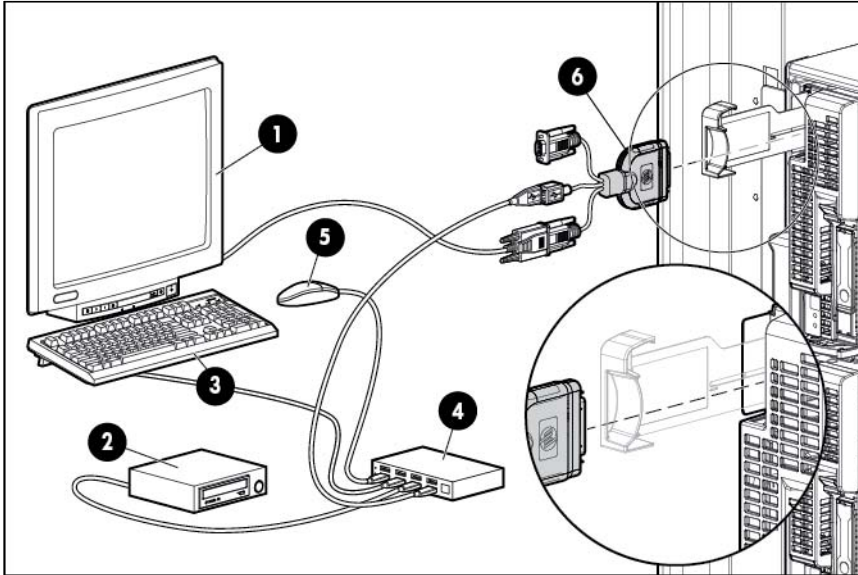

Item	Description
1	Monitor
2	USB CD/DVD-ROM drive
3	USB keyboard
4	USB hub
5	USB mouse
6	HP c-Class Blade SUV Cable

Troubleshooting

Troubleshooting resources

The *HP ProLiant Gen8 Troubleshooting Guide, Volume I: Troubleshooting* provides procedures for resolving common problems and comprehensive courses of action for fault isolation and identification, issue resolution, and software maintenance on ProLiant servers and server blades. To view the guide, select a language:

- English (http://www.hp.com/support/ProLiant_TSG_v1_en)
- French (http://www.hp.com/support/ProLiant_TSG_v1_fr)
- Spanish (http://www.hp.com/support/ProLiant_TSG_v1_sp)
- German (http://www.hp.com/support/ProLiant_TSG_v1_gr)
- Japanese (http://www.hp.com/support/ProLiant_TSG_v1_jp)
- Simplified Chinese (http://www.hp.com/support/ProLiant_TSG_v1_sc)

The *HP ProLiant Gen8 Troubleshooting Guide, Volume II: Error Messages* provides a list of error messages and information to assist with interpreting and resolving error messages on ProLiant servers and server blades. To view the guide, select a language:

- English (http://www.hp.com/support/ProLiant_EMG_v1_en)
- French (http://www.hp.com/support/ProLiant_EMG_v1_fr)
- Spanish (http://www.hp.com/support/ProLiant_EMG_v1_sp)
- German (http://www.hp.com/support/ProLiant_EMG_v1_gr)
- Japanese (http://www.hp.com/support/ProLiant_EMG_v1_jp)
- Simplified Chinese (http://www.hp.com/support/ProLiant_EMG_v1_sc)

Component identification

Front panel components

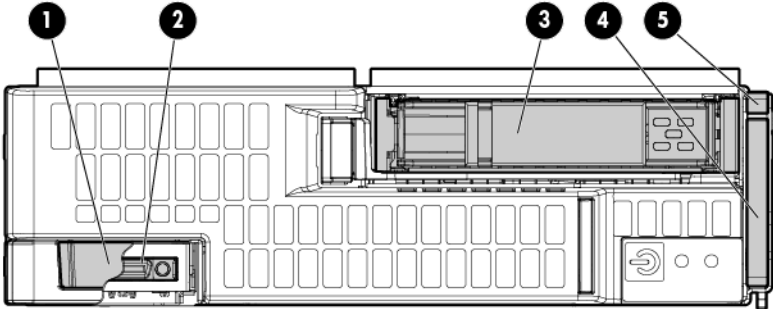

Item	Description
1	Serial label pull tab
2	HP c-Class Blade SUV connector* (behind the serial label pull tab)
3	Drive bay
4	Server blade release lever
5	Server blade release button

*The SUV connector and the HP c-Class Blade SUV Cable are used for some server blade configuration and diagnostic procedures.

Front panel LEDs and buttons

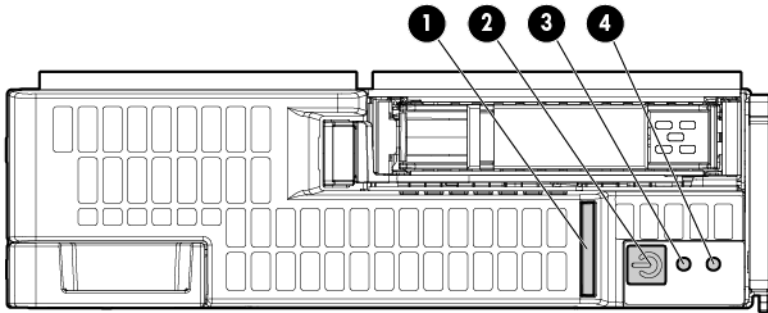

Item	Description	Status
1	Health status LED bar	Solid Green = Normal (System is powered on.) Flashing Green = Power On/Standby Button service is being initialized. Flashing Amber = Degraded condition Flashing Red = Critical condition Off = Normal (System is in standby.)
2	Power On/Standby button and System power LED	Solid Green = System is powered on. Flashing Green = System is waiting to power on; Power On/Standby button is pressed. Solid Amber = System is in standby; Power On/Standby Button service is initialized. Off and the Health Status LED bar is off = The system has no power. Off and the Health Status LED bar is flashing green = The Power On/Standby Button service is being initialized.
3	UID LED	Solid Blue = Identified Flashing Blue = Active remote management Off = No active remote management
4	FlexibleLOM LED	Green = Network linked Flashing Green = Network activity Off = No link or activity



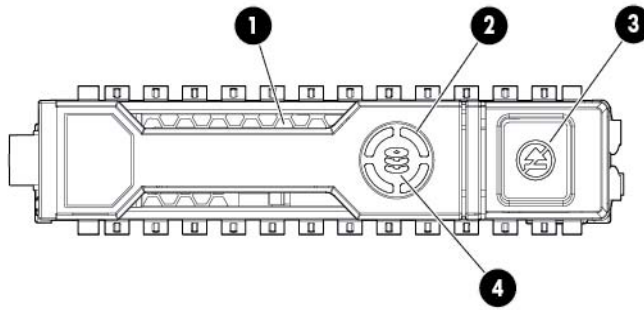

Drive LED definitions



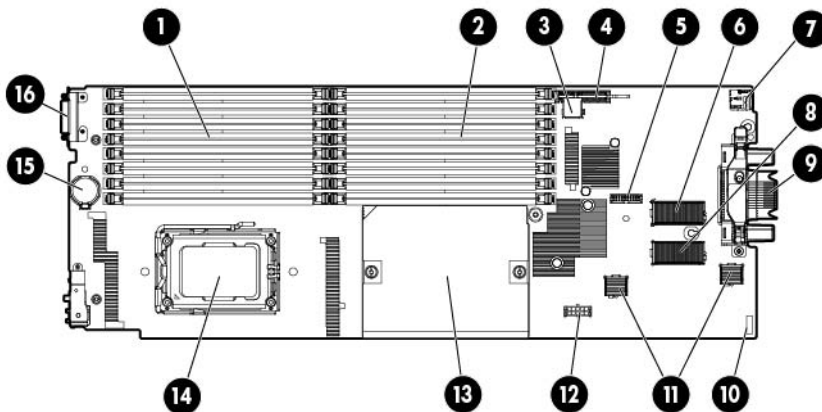



Item	LED	Status	Definition
1	Locate	Solid blue	The drive is being identified by a host application.
		Flashing blue	The drive carrier firmware is being updated or requires an update.
2	Activity ring	Rotating green	Drive activity
		Off	No drive activity
3	Do not remove	Solid white	Do not remove the drive. Removing the drive causes one or more of the logical drives to fail.
		Off	Removing the drive does not cause a logical drive to fail.
4	Drive status	Solid green	The drive is a member of one or more logical drives.
		Flashing green	The drive is rebuilding or performing a RAID migration, stripe size migration, capacity expansion, or logical drive extension, or is erasing.
		Flashing amber/green	The drive is a member of one or more logical drives and predicts the drive will fail.
		Flashing amber	The drive is not configured and predicts the drive will fail.
		Solid amber	The drive has failed.
		Off	The drive is not configured by a RAID controller.

System board components



Item	Description
1	Processor 2 DIMM slots
2	Processor 1 DIMM slots
3	Internal USB connector
4	Pass-thru board
5	TPM connector
6	Mezzanine connector 1 (Type A mezzanine only) 
7	MicroSD card slot
8	Mezzanine connector 2 (Type A or type B mezzanine)  
9	Enclosure connector
10	System maintenance switch
11	FlexibleLOM connectors (2) 
12	Drive power cable connector
13	Processor socket 1 (populated)
14	Processor socket 2
15	System battery
16	HP c-Class Blade SUV cable connector

The symbols     correspond to the symbols located on the interconnect bays. For more information, see the *HP ProLiant BL465c Gen8 Server Blade Installation Instructions* on the HP website (<http://www.hp.com/support>).

System maintenance switch

Position	Default	Function
S1	Off	Off = HP iLO security is enabled. On = HP iLO security is disabled.
S2	Off	Off = System configuration can be changed. On = System configuration is locked.
S3	Off	Reserved
S4	Off	Reserved
S5	Off	Off = Power-on password is enabled. On = Power-on password is disabled.
S6	Off	Off = No function On = ROM reads system configuration as invalid.
S7	—	Reserved
S8	—	Reserved
S9	—	Reserved
S10	—	Reserved
S11	—	Reserved
S12	—	Reserved

To access redundant ROM, set S1, S5, and S6 to on.

When the system maintenance switch position 6 is set to the On position, the system is prepared to erase all system configuration settings from both CMOS and NVRAM.



CAUTION: Clearing CMOS and/or NVRAM deletes configuration information. Be sure to properly configure the server or data loss could occur.

Mezzanine connector definitions

A PCIe x8 mezzanine connector supports x16 cards at up to x8 speeds.

Item	PCIe
Mezzanine connector 1	x8, Type A mezzanine card only
Mezzanine connector 2	x16, Type A or B mezzanine card

DIMM slot locations

DIMM slots are numbered sequentially (1 through 8) for each processor. The supported AMP modes use the alpha assignments for population order, and the slot numbers designate the DIMM slot ID for spare replacement.

The arrow points to the front of the server blade.

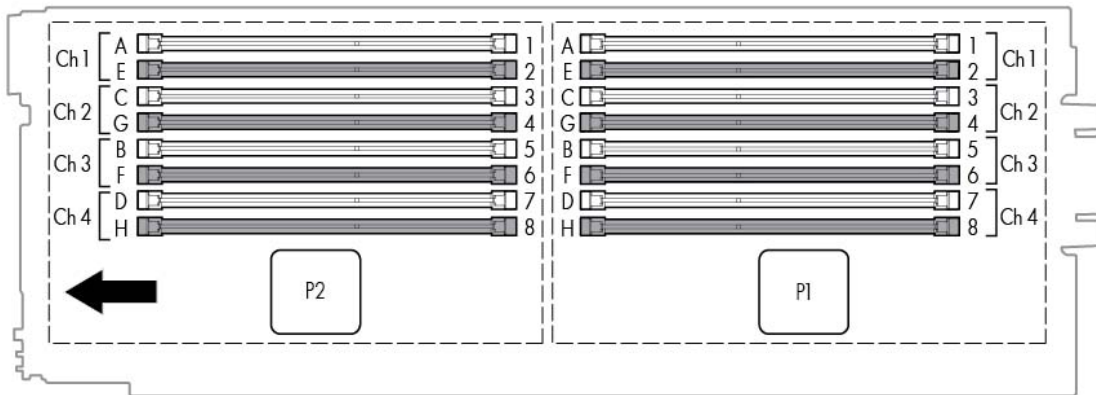

DIMM identification

To determine DIMM characteristics, use the label attached to the DIMM and the following illustration and table.

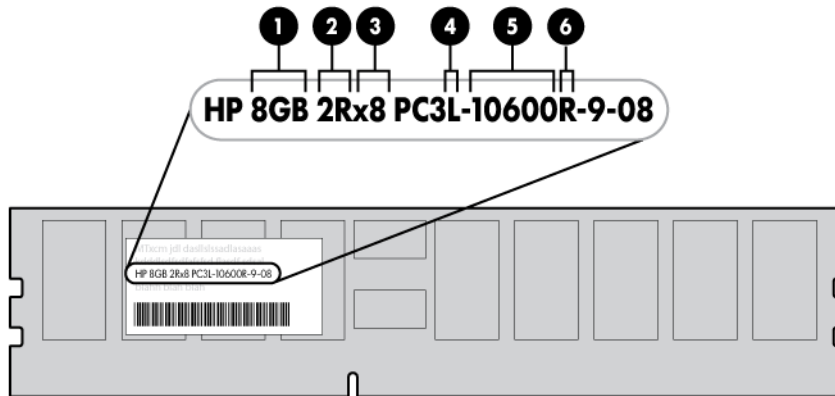

Item	Description	Definition
1	Size	—
2	Rank	1R = Single-rank 2R = Dual-rank 3R = Three-rank 4R = Quad-rank
3	Data width	x4 = 4-bit x8 = 8-bit
4	Voltage rating	L = Low voltage (1.35V) U = Ultra low voltage (1.25V) Blank or omitted = Standard
5	Memory speed	12800 = 1600-MT/s 10600 = 1333-MT/s 8500 = 1066-MT/s
6	DIMM type	R = RDIMM (registered) E = UDIMM (unbuffered with ECC) L = LRDIMM (load reduced)

For the latest supported memory information, see the QuickSpecs on the HP website (<http://h18000.www1.hp.com/products/quickspecs/ProductBulletin.html>). At the website, choose the geographic region, and then locate the product by name or product category.

Tool location

A Torx T-15 screwdriver is located on the DIMM baffle.

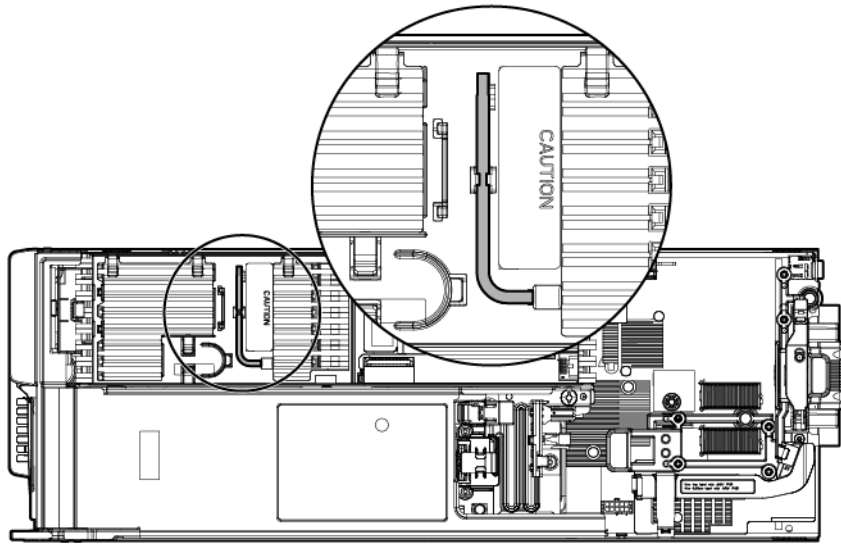

HP c-Class Blade SUV Cable

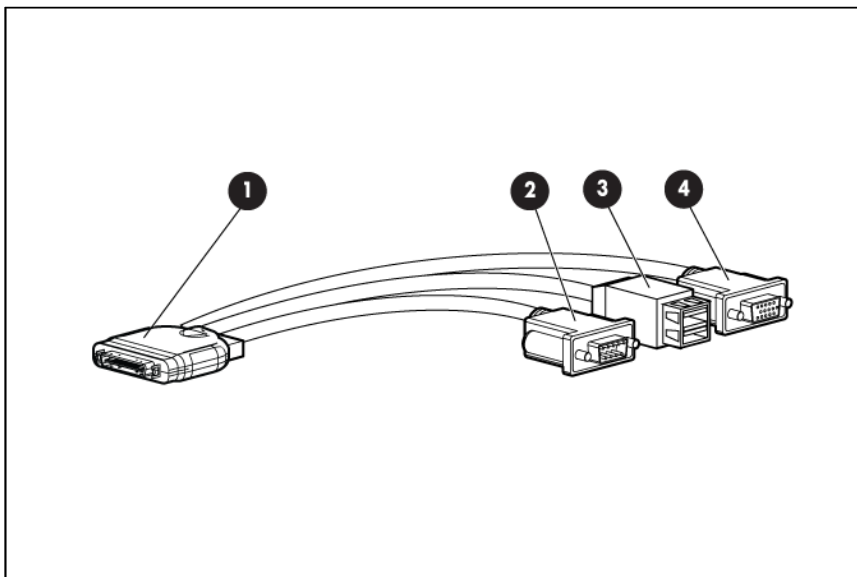

Item	Connector	Description
1	Server blade	For connecting to the SUV connector on the server blade front panel
2	Video	For connecting a video monitor
3	USB	For connecting up to two USB devices
4	Serial	For trained personnel to connect a null modem serial cable and perform advanced diagnostic procedures

Specifications

Environmental specifications

Specification	Value
	—
Temperature range*	
Operating	10°C to 35°C (50°F to 95°F)
Non-operating	-30°C to 60°C (-22°F to 140°F)
Relative humidity (noncondensing)**	—
Operating	10% to 90% @ 28°C (82.4°F)
Non-operating	5% to 95% @ 38.7°C (101.7°F)
Altitude†	—
Operating	3050 m (10,000 ft)
Non-operating	9144 m (30,000 ft)

* The following temperature conditions and limitations apply:

- All temperature ratings shown are for sea level.
- An altitude derating of 1°C per 304.8 m (1.8°F per 1,000 ft) up to 3048 m (10,000 ft) applies.
- No direct sunlight is allowed.
- The maximum permissible rate of change is 10°C/hr (18°F/hr).
- The type and number of options installed may reduce the upper temperature and humidity limits.
- Operating with a fan fault or above 30°C (86°F) may reduce system performance.

** Storage maximum humidity of 95% is based on a maximum temperature of 45°C (113°F).

†Maximum storage altitude corresponds to a minimum pressure of 70 kPa (10.1 psia).

Server blade specifications

Specification	Value
Height	5.56 cm (2.19 in)
Depth	50.95 cm (20.06 in)
Width	18.16 cm (7.15 in)
Weight (maximum)	6.3 kg (13.9 lb)

Acronyms and abbreviations

AMP

Advanced Memory Protection

FBWC

flash-backed write cache

iLO

Integrated Lights-Out

IML

Integrated Management Log

LRDIMM

load reduced dual in-line memory module

MLC

multilevel cell

POST

Power-On Self Test

RBSU

ROM-Based Setup Utility

RDIMM

registered dual in-line memory module

SAS

serial attached SCSI

SATA

serial ATA

SIM

Systems Insight Manager

SLC

single-level cell

UDIMM

unregistered dual in-line memory module

UID

unit identification

USB

universal serial bus

Documentation feedback

HP is committed to providing documentation that meets your needs. To help us improve the documentation, send any errors, suggestions, or comments to Documentation Feedback (<mailto:docsfeedback@hp.com>). Include the document title and part number, version number, or the URL when submitting your feedback.

Index

A

access panel 15, 24
Active Health System 61

B

batteries, replacing 48
battery 15, 48, 71
buttons 69

C

cables 15, 64, 65
cabling 64, 65
cabling, drive 65
cabling, hard drive 65
capacitor pack 36, 37
cautions 21
components 15, 21, 31, 69
components, identification 15, 69
components, mechanical 15
components, system 15
connectors 69
controller 15, 34
CSR (customer self repair) 5
customer self repair (CSR) 5, 15

D

data recovery 38
diagnosing problems 68
diagnostic tools 60, 61
diagnostics utility 61
DIMM baffles 15, 27
DIMM identification 74
DIMM slot locations 71, 73
DIMMs 15, 28, 71, 73
documentation 79
documentation feedback 79
drive backplane 15
drive bays 69
drive blank 15, 25
drive cabling 64, 65
drive, replacing 25

drives 15, 25, 65, 71

E

electrostatic discharge 21
enclosure connector 71
enclosure connector cover 15, 26, 71
environmental specifications 76
error messages 68
external cables 65
external USB functionality 63

F

FBWC capacitor cabling 64
FBWC capacitor pack 15, 64
FBWC procedures 36, 37, 38
FC mezzanine 15
features 69
Fibre Channel mezzanine 15
firmware upgrade utility, troubleshooting 68
flash-backed write cache capacitor pack 64
flash-backed write cache procedures 36, 38
FlexibleLOM 32
FlexibleLOM connectors 71
FlexibleLOM LED 70
front panel buttons 70
front panel components 69
front panel LEDs 70
front panel/drive cage assembly 15, 39
front panel/hard drive cage assembly 15, 39

H

hard drive backplane 15
hard drive backplane connector 71
hard drive bays 69
hard drive blanks 15, 25
hard drive cabling 65
hard drive LEDs 71
hard drive, replacing 25
hard drives, determining status of 71
hardware kit 15, 26, 29
health LEDs 70
health status LED bar 70
heatsink 15, 42

heatsink blank 15, 40, 42
HP c-Class Blade SUV Cable 15, 65, 69, 75
HP Insight Diagnostics 21, 61
HP Insight Diagnostics survey functionality 61

I

illustrated parts catalog 15
iLO (Integrated Lights-Out) 61, 62
IML (Integrated Management Log) 62
InfiniBand mezzanine 15
Insight Diagnostics 21, 61
Integrated Management Log (IML) 62
internal USB functionality 63

L

LED, health 70
LED, power button 70
LED, system power 70
LEDs 71
LEDs, hard drive 71
LEDs, NIC 70
LEDs, SAS hard drive 71
LEDs, troubleshooting 68
LEDs, unit identification (UID) 70
local KVM, accessing a server blade with 65
local media devices, accessing 66

M

management tools 60
mechanical components 15
memory 15, 73, 74
mezzanine assembly 15, 29
mezzanine assembly guide pins 15
mezzanine assembly retainer assembly 15
mezzanine board connectors 71
mezzanine boards 15, 37
mezzanine card 31
mezzanine connectors 71, 73
mezzanine option capacitor pack 37

N

NAND flash module 15, 35
NIC (network interface card) 71

P

part numbers 15
power button LED 70
powering down 22

preparation procedures 22
problem diagnosis 68
processor socket 71
processor tool 44
processors 15, 44, 71

Q

QuickSpecs 60

R

RBSU (ROM-Based Setup Utility) 60
RBSU configuration 60
recovering the data from the cache 38
release button 69
removal and replacement procedures 21
removing the server blade 23
replacement procedures 21
replacing the system board 49
required tools 21
ROM-Based Setup Utility (RBSU) 60

S

safety considerations 21
safety information 21
SAS controller 15, 34, 36
SAS controller capacitor pack 36
SAS drives 15, 71
screwdriver, T-10 Torx 21, 75
screwdriver, T-15 Torx 21, 75
serial connector 75
serial label pull tab 41, 69
server blade release lever 56, 69
server specifications 76
specifications 76
specifications, environmental 76
specifications, server blade 76
static electricity 21
SUV connector 65, 69, 75
symbols on equipment 22
system board 15
system board battery 15, 48, 71
system board components 71
system board replacement 49
system components 69
system maintenance switch 71, 72

T

T-10 Torx screwdriver 21

- T-15 Torx screwdriver 21, 75
- tool locations 75
- tools 21, 75
- Torx screwdriver 21, 75
- TPM (Trusted Platform Module) 59
- troubleshooting 68
- troubleshooting resources 68
- troubleshooting, firmware upgrade utility 68
- Trusted Platform Module (TPM) 15, 59

U

- USB connectors 75
- USB devices 65
- USB support 62
- utilities 60
- utilities, deployment 60

V

- video connector 75
- video connector cabling 75
- video devices 65

W

- warnings 21