

# HP ProLiant BL685c Generation 5 Server Blade Maintenance and Service Guide

## Abstract

This guide describes identification and maintenance procedures, diagnostic tools, specifications and requirements for hardware components and software. This guide is for an experienced service technician. HP assumes you are qualified in the servicing of computer equipment, trained in recognizing hazards in products, and are familiar with weight and stability precautions.



Part Number: 457458-005  
September 2011  
Edition: 5

© Copyright 2008, 2011 Hewlett-Packard Development Company, L.P.

The information contained herein is subject to change without notice. The only warranties for HP products and services are set forth in the express warranty statements accompanying such products and services. Nothing herein should be construed as constituting an additional warranty. HP shall not be liable for technical or editorial errors or omissions contained herein.

Microsoft® and Windows® are U.S. registered trademarks of Microsoft Corporation.

AMD Opteron® is a trademark of Advanced Micro Devices, Inc.

---

# Contents

Customer self repair .....	5
Parts only warranty service.....	5
Illustrated parts catalog .....	16
Server blade components.....	16
Removal and replacement procedures .....	21
Required tools.....	21
Safety considerations.....	21
Preventing electrostatic discharge .....	21
Server blade warnings and cautions .....	21
Symbols on equipment.....	22
Server blade preparation .....	22
Power down the server blade .....	22
Remove the server blade .....	23
Access panel .....	24
Hard drive blank.....	25
Hard drive.....	25
DIMM baffle.....	26
DIMMs.....	26
Mezzanine card .....	27
HP Smart Array E200i Controller cache module .....	28
HP Smart Array E200i Controller cache module battery pack .....	29
SAS cable .....	29
Hard drive backplane.....	30
Front panel/hard drive cage assembly .....	31
Server blade handle .....	32
Release button .....	32
Heatsink.....	33
Processor.....	37
System battery .....	43
System board .....	44
Cabling .....	50
SAS cable routing .....	50
Using the HP c-Class Blade SUV Cable.....	50
Connecting locally to a server blade with video and USB devices .....	50
Diagnostic tools .....	53
Troubleshooting resources .....	53
HP Insight Diagnostics .....	53
Integrated Management Log.....	53
Array Diagnostic Utility .....	54
USB support and functionality.....	54
USB support .....	54
Internal USB functionality .....	54
External USB functionality .....	54

Component identification.....	56
Front panel components.....	56
Front panel LEDs.....	57
SAS and SATA hard drive LEDs.....	58
SAS and SATA hard drive LED combinations.....	58
System board components.....	59
Mezzanine connector definitions.....	60
DIMM slots.....	60
System maintenance switch.....	61
System maintenance switch procedures.....	61
HP c-Class Blade SUV Cable.....	62
Specifications.....	63
Environmental specifications.....	63
Server blade specifications.....	63
Acronyms and abbreviations.....	64
Index.....	66

---

# Customer self repair

HP products are designed with many Customer Self Repair (CSR) parts to minimize repair time and allow for greater flexibility in performing defective parts replacement. If during the diagnosis period HP (or HP service providers or service partners) identifies that the repair can be accomplished by the use of a CSR part, HP will ship that part directly to you for replacement. There are two categories of CSR parts:

- **Mandatory**—Parts for which customer self repair is mandatory. If you request HP to replace these parts, you will be charged for the travel and labor costs of this service.
- **Optional**—Parts for which customer self repair is optional. These parts are also designed for customer self repair. If, however, you require that HP replace them for you, there may or may not be additional charges, depending on the type of warranty service designated for your product.

**NOTE:** Some HP parts are not designed for customer self repair. In order to satisfy the customer warranty, HP requires that an authorized service provider replace the part. These parts are identified as "No" in the Illustrated Parts Catalog.

Based on availability and where geography permits, CSR parts will be shipped for next business day delivery. Same day or four-hour delivery may be offered at an additional charge where geography permits. If assistance is required, you can call the HP Technical Support Center and a technician will help you over the telephone. HP specifies in the materials shipped with a replacement CSR part whether a defective part must be returned to HP. In cases where it is required to return the defective part to HP, you must ship the defective part back to HP within a defined period of time, normally five (5) business days. The defective part must be returned with the associated documentation in the provided shipping material. Failure to return the defective part may result in HP billing you for the replacement. With a customer self repair, HP will pay all shipping and part return costs and determine the courier/carrier to be used.

For more information about HP's Customer Self Repair program, contact your local service provider. For the North American program, refer to the HP website (<http://www.hp.com/go/selfrepair>).

## Parts only warranty service

Your HP Limited Warranty may include a parts only warranty service. Under the terms of parts only warranty service, HP will provide replacement parts free of charge.

For parts only warranty service, CSR part replacement is mandatory. If you request HP to replace these parts, you will be charged for the travel and labor costs of this service.

## Réparation par le client (CSR)

Les produits HP comportent de nombreuses pièces CSR (Customer Self Repair = réparation par le client) afin de minimiser les délais de réparation et faciliter le remplacement des pièces défectueuses. Si pendant la période de diagnostic, HP (ou ses partenaires ou mainteneurs agréés) détermine que la réparation peut être effectuée à l'aide d'une pièce CSR, HP vous l'envoie directement. Il existe deux catégories de pièces CSR:

Obligatoire - Pièces pour lesquelles la réparation par le client est obligatoire. Si vous demandez à HP de remplacer ces pièces, les coûts de déplacement et main d'œuvre du service vous seront facturés.

Facultatif - Pièces pour lesquelles la réparation par le client est facultative. Ces pièces sont également conçues pour permettre au client d'effectuer lui-même la réparation. Toutefois, si vous demandez à HP de remplacer ces pièces, l'intervention peut ou non vous être facturée, selon le type de garantie applicable à votre produit.

**REMARQUE:** Certaines pièces HP ne sont pas conçues pour permettre au client d'effectuer lui-même la réparation. Pour que la garantie puisse s'appliquer, HP exige que le remplacement de la pièce soit effectué par un Mainteneur Agréé. Ces pièces sont identifiées par la mention "Non" dans le Catalogue illustré.

Les pièces CSR sont livrées le jour ouvré suivant, dans la limite des stocks disponibles et selon votre situation géographique. Si votre situation géographique le permet et que vous demandez une livraison le jour même ou dans les 4 heures, celle-ci vous sera facturée. Pour bénéficier d'une assistance téléphonique, appelez le Centre d'assistance technique HP. Dans les documents envoyés avec la pièce de rechange CSR, HP précise s'il est nécessaire de lui retourner la pièce défectueuse. Si c'est le cas, vous devez le faire dans le délai indiqué, généralement cinq (5) jours ouvrés. La pièce et sa documentation doivent être retournées dans l'emballage fourni. Si vous ne retournez pas la pièce défectueuse, HP se réserve le droit de vous facturer les coûts de remplacement. Dans le cas d'une pièce CSR, HP supporte l'ensemble des frais d'expédition et de retour, et détermine la société de courses ou le transporteur à utiliser.

Pour plus d'informations sur le programme CSR de HP, contactez votre Mainteneur Agréé local. Pour plus d'informations sur ce programme en Amérique du Nord, consultez le site Web HP (<http://www.hp.com/go/selfrepair>).

## Service de garantie "pièces seules"

Votre garantie limitée HP peut inclure un service de garantie "pièces seules". Dans ce cas, les pièces de rechange fournies par HP ne sont pas facturées.

Dans le cadre de ce service, la réparation des pièces CSR par le client est obligatoire. Si vous demandez à HP de remplacer ces pièces, les coûts de déplacement et main d'œuvre du service vous seront facturés.

## Riparazione da parte del cliente

Per abbreviare i tempi di riparazione e garantire una maggiore flessibilità nella sostituzione di parti difettose, i prodotti HP sono realizzati con numerosi componenti che possono essere riparati direttamente dal cliente (CSR, Customer Self Repair). Se in fase di diagnostica HP (o un centro di servizi o di assistenza HP) identifica il guasto come riparabile mediante un ricambio CSR, HP lo spedisce direttamente al cliente per la sostituzione. Vi sono due categorie di parti CSR:

**Obbligatorie** – Parti che devono essere necessariamente riparate dal cliente. Se il cliente ne affida la riparazione ad HP, deve sostenere le spese di spedizione e di manodopera per il servizio.

**Opzionali** – Parti la cui riparazione da parte del cliente è facoltativa. Si tratta comunque di componenti progettati per questo scopo. Se tuttavia il cliente ne richiede la sostituzione ad HP, potrebbe dover sostenere spese aggiuntive a seconda del tipo di garanzia previsto per il prodotto.

**NOTA:** alcuni componenti HP non sono progettati per la riparazione da parte del cliente. Per rispettare la garanzia, HP richiede che queste parti siano sostituite da un centro di assistenza autorizzato. Tali parti sono identificate da un "No" nel Catalogo illustrato dei componenti.

In base alla disponibilità e alla località geografica, le parti CSR vengono spedite con consegna entro il giorno lavorativo seguente. La consegna nel giorno stesso o entro quattro ore è offerta con un supplemento di costo solo in alcune zone. In caso di necessità si può richiedere l'assistenza telefonica di un addetto del centro di supporto tecnico HP. Nel materiale fornito con una parte di ricambio CSR, HP specifica se il cliente deve restituire dei componenti. Qualora sia richiesta la resa ad HP del componente difettoso, lo si deve spedire ad HP entro un determinato periodo di tempo, generalmente cinque (5) giorni lavorativi. Il componente difettoso deve essere restituito con la documentazione associata nell'imballo di spedizione fornito. La mancata restituzione del componente può comportare la fatturazione del ricambio da parte di HP. Nel caso di riparazione da parte del cliente, HP sostiene tutte le spese di spedizione e resa e sceglie il corriere/vettore da utilizzare.

Per ulteriori informazioni sul programma CSR di HP contattare il centro di assistenza di zona. Per il programma in Nord America fare riferimento al sito Web HP (<http://www.hp.com/go/selfrepair>).

## Servizio di garanzia per i soli componenti

La garanzia limitata HP può includere un servizio di garanzia per i soli componenti. Nei termini di garanzia del servizio per i soli componenti, HP fornirà gratuitamente le parti di ricambio.

Per il servizio di garanzia per i soli componenti è obbligatoria la formula CSR che prevede la riparazione da parte del cliente. Se il cliente invece richiede la sostituzione ad HP, dovrà sostenere le spese di spedizione e di manodopera per il servizio.

## Customer Self Repair

HP Produkte enthalten viele CSR-Teile (Customer Self Repair), um Reparaturzeiten zu minimieren und höhere Flexibilität beim Austausch defekter Bauteile zu ermöglichen. Wenn HP (oder ein HP Servicepartner) bei der Diagnose feststellt, dass das Produkt mithilfe eines CSR-Teils repariert werden kann, sendet Ihnen HP dieses Bauteil zum Austausch direkt zu. CSR-Teile werden in zwei Kategorien unterteilt:

**Zwingend** – Teile, für die das Customer Self Repair-Verfahren zwingend vorgegeben ist. Wenn Sie den Austausch dieser Teile von HP vornehmen lassen, werden Ihnen die Anfahrt- und Arbeitskosten für diesen Service berechnet.

**Optional** – Teile, für die das Customer Self Repair-Verfahren optional ist. Diese Teile sind auch für Customer Self Repair ausgelegt. Wenn Sie jedoch den Austausch dieser Teile von HP vornehmen lassen möchten, können bei diesem Service je nach den für Ihr Produkt vorgesehenen Garantiebedingungen zusätzliche Kosten anfallen.

**HINWEIS:** Einige Teile sind nicht für Customer Self Repair ausgelegt. Um den Garantieanspruch des Kunden zu erfüllen, muss das Teil von einem HP Servicepartner ersetzt werden. Im illustrierten Teilekatalog sind diese Teile mit „No“ bzw. „Nein“ gekennzeichnet.

CSR-Teile werden abhängig von der Verfügbarkeit und vom Lieferziel am folgenden Geschäftstag geliefert. Für bestimmte Standorte ist eine Lieferung am selben Tag oder innerhalb von vier Stunden gegen einen Aufpreis verfügbar. Wenn Sie Hilfe benötigen, können Sie das HP technische Support Center anrufen und sich von einem Mitarbeiter per Telefon helfen lassen. Den Materialien, die mit einem CSR-Ersatzteil geliefert werden, können Sie entnehmen, ob das defekte Teil an HP zurückgeschickt werden muss. Wenn es erforderlich ist, das defekte Teil an HP zurückzuschicken, müssen Sie dies innerhalb eines vorgegebenen Zeitraums tun, in der Regel innerhalb von fünf (5) Geschäftstagen. Das defekte Teil muss mit der zugehörigen Dokumentation in der Verpackung zurückgeschickt werden, die im Lieferumfang enthalten ist. Wenn Sie das

defekte Teil nicht zurückschicken, kann HP Ihnen das Ersatzteil in Rechnung stellen. Im Falle von Customer Self Repair kommt HP für alle Kosten für die Lieferung und Rücksendung auf und bestimmt den Kurier-/Frachtdienst.

Weitere Informationen über das HP Customer Self Repair Programm erhalten Sie von Ihrem Servicepartner vor Ort. Informationen über das CSR-Programm in Nordamerika finden Sie auf der HP Website unter (<http://www.hp.com/go/selfrepair>).

## Parts-only Warranty Service (Garantieservice ausschließlich für Teile)

Ihre HP Garantie umfasst möglicherweise einen Parts-only Warranty Service (Garantieservice ausschließlich für Teile). Gemäß den Bestimmungen des Parts-only Warranty Service stellt HP Ersatzteile kostenlos zur Verfügung.

Für den Parts-only Warranty Service ist das CSR-Verfahren zwingend vorgegeben. Wenn Sie den Austausch dieser Teile von HP vornehmen lassen, werden Ihnen die Anfahrt- und Arbeitskosten für diesen Service berechnet.

## Reparaciones del propio cliente

Los productos de HP incluyen muchos componentes que el propio usuario puede reemplazar (*Customer Self Repair*, CSR) para minimizar el tiempo de reparación y ofrecer una mayor flexibilidad a la hora de realizar sustituciones de componentes defectuosos. Si, durante la fase de diagnóstico, HP (o los proveedores o socios de servicio de HP) identifica que una reparación puede llevarse a cabo mediante el uso de un componente CSR, HP le enviará dicho componente directamente para que realice su sustitución. Los componentes CSR se clasifican en dos categorías:

- **Obligatorio:** componentes para los que la reparación por parte del usuario es obligatoria. Si solicita a HP que realice la sustitución de estos componentes, tendrá que hacerse cargo de los gastos de desplazamiento y de mano de obra de dicho servicio.
- **Opcional:** componentes para los que la reparación por parte del usuario es opcional. Estos componentes también están diseñados para que puedan ser reparados por el usuario. Sin embargo, si precisa que HP realice su sustitución, puede o no conllevar costes adicionales, dependiendo del tipo de servicio de garantía correspondiente al producto.

**NOTA:** Algunos componentes no están diseñados para que puedan ser reparados por el usuario. Para que el usuario haga valer su garantía, HP pone como condición que un proveedor de servicios autorizado realice la sustitución de estos componentes. Dichos componentes se identifican con la palabra "No" en el catálogo ilustrado de componentes.

Según la disponibilidad y la situación geográfica, los componentes CSR se enviarán para que lleguen a su destino al siguiente día laborable. Si la situación geográfica lo permite, se puede solicitar la entrega en el mismo día o en cuatro horas con un coste adicional. Si precisa asistencia técnica, puede llamar al Centro de asistencia técnica de HP y recibirá ayuda telefónica por parte de un técnico. Con el envío de materiales para la sustitución de componentes CSR, HP especificará si los componentes defectuosos deberán devolverse a HP. En aquellos casos en los que sea necesario devolver algún componente a HP, deberá hacerlo en el periodo de tiempo especificado, normalmente cinco días laborables. Los componentes defectuosos deberán devolverse con toda la documentación relacionada y con el embalaje de envío. Si no



enviara el componente defectuoso requerido, HP podrá cobrarle por el de sustitución. En el caso de todas sustituciones que lleve a cabo el cliente, HP se hará cargo de todos los gastos de envío y devolución de componentes y escogerá la empresa de transporte que se utilice para dicho servicio.

Para obtener más información acerca del programa de Reparaciones del propio cliente de HP, póngase en contacto con su proveedor de servicios local. Si está interesado en el programa para Norteamérica, visite la página web de HP siguiente (<http://www.hp.com/go/selfrepair>).

## Servicio de garantía exclusivo de componentes

La garantía limitada de HP puede que incluya un servicio de garantía exclusivo de componentes. Según las condiciones de este servicio exclusivo de componentes, HP le facilitará los componentes de repuesto sin cargo adicional alguno.

Para este servicio de garantía exclusivo de componentes, es obligatoria la sustitución de componentes por parte del usuario (CSR). Si solicita a HP que realice la sustitución de estos componentes, tendrá que hacerse cargo de los gastos de desplazamiento y de mano de obra de dicho servicio.

## Customer Self Repair

Veel onderdelen in HP producten zijn door de klant zelf te repareren, waardoor de reparatieduur tot een minimum beperkt kan blijven en de flexibiliteit in het vervangen van defecte onderdelen groter is. Deze onderdelen worden CSR-onderdelen (Customer Self Repair) genoemd. Als HP (of een HP Service Partner) bij de diagnose vaststelt dat de reparatie kan worden uitgevoerd met een CSR-onderdeel, verzendt HP dat onderdeel rechtstreeks naar u, zodat u het defecte onderdeel daarmee kunt vervangen. Er zijn twee categorieën CSR-onderdelen:

**Verplicht:** Onderdelen waarvoor reparatie door de klant verplicht is. Als u HP verzoekt deze onderdelen voor u te vervangen, worden u voor deze service reiskosten en arbeidsloon in rekening gebracht.

**Optioneel:** Onderdelen waarvoor reparatie door de klant optioneel is. Ook deze onderdelen zijn ontworpen voor reparatie door de klant. Als u echter HP verzoekt deze onderdelen voor u te vervangen, kunnen daarvoor extra kosten in rekening worden gebracht, afhankelijk van het type garantieservice voor het product.

**OPMERKING:** Sommige HP onderdelen zijn niet ontwikkeld voor reparatie door de klant. In verband met de garantievoorwaarden moet het onderdeel door een geautoriseerde Service Partner worden vervangen. Deze onderdelen worden in de geïllustreerde onderdelencatalogus aangemerkt met "Nee".

Afhankelijk van de leverbaarheid en de locatie worden CSR-onderdelen verzonden voor levering op de eerstvolgende werkdag. Levering op dezelfde dag of binnen vier uur kan tegen meerkosten worden aangeboden, indien dit mogelijk is gezien de locatie. Indien assistentie gewenst is, belt u een HP Service Partner om via de telefoon technische ondersteuning te ontvangen. HP vermeldt in de documentatie bij het vervangende CSR-onderdeel of het defecte onderdeel aan HP moet worden geretourneerd. Als het defecte onderdeel aan HP moet worden teruggezonden, moet u het defecte onderdeel binnen een bepaalde periode, gewoonlijk vijf (5) werkdagen, retourneren aan HP. Het defecte onderdeel moet met de bijbehorende documentatie worden geretourneerd in het meegeleverde verpakkingsmateriaal. Als u het defecte onderdeel niet terugzendt, kan HP u voor het vervangende onderdeel kosten in rekening brengen. Bij reparatie door de klant betaalt HP alle verzendkosten voor het vervangende en geretourneerde onderdeel en kiest HP zelf welke koerier/transportonderneming hiervoor wordt gebruikt.

Neem contact op met een Service Partner voor meer informatie over het Customer Self Repair programma van HP. Informatie over Service Partners vindt u op de HP website (<http://www.hp.com/go/selfrepair>).

## Garantieservice "Parts Only"

Het is mogelijk dat de HP garantie alleen de garantieservice "Parts Only" omvat. Volgens de bepalingen van de Parts Only garantieservice zal HP kosteloos vervangende onderdelen ter beschikking stellen.

Voor de Parts Only garantieservice is vervanging door CSR-onderdelen verplicht. Als u HP verzoekt deze onderdelen voor u te vervangen, worden u voor deze service reiskosten en arbeidsloon in rekening gebracht.

## Reparo feito pelo cliente

Os produtos da HP são projetados com muitas peças para reparo feito pelo cliente (CSR) de modo a minimizar o tempo de reparo e permitir maior flexibilidade na substituição de peças com defeito. Se, durante o período de diagnóstico, a HP (ou fornecedores/parceiros de serviço da HP) concluir que o reparo pode ser efetuado pelo uso de uma peça CSR, a peça de reposição será enviada diretamente ao cliente. Existem duas categorias de peças CSR:

**Obrigatória** – Peças cujo reparo feito pelo cliente é obrigatório. Se desejar que a HP substitua essas peças, serão cobradas as despesas de transporte e mão-de-obra do serviço.

**Opcional** – Peças cujo reparo feito pelo cliente é opcional. Essas peças também são projetadas para o reparo feito pelo cliente. No entanto, se desejar que a HP as substitua, pode haver ou não a cobrança de taxa adicional, dependendo do tipo de serviço de garantia destinado ao produto.

**OBSERVAÇÃO:** Algumas peças da HP não são projetadas para o reparo feito pelo cliente. A fim de cumprir a garantia do cliente, a HP exige que um técnico autorizado substitua a peça. Essas peças estão identificadas com a marca "No" (Não), no catálogo de peças ilustrado.

Conforme a disponibilidade e o local geográfico, as peças CSR serão enviadas no primeiro dia útil após o pedido. Onde as condições geográficas permitirem, a entrega no mesmo dia ou em quatro horas pode ser feita mediante uma taxa adicional. Se precisar de auxílio, entre em contato com o Centro de suporte técnico da HP para que um técnico o ajude por telefone. A HP especifica nos materiais fornecidos com a peça CSR de reposição se a peça com defeito deve ser devolvida à HP. Nos casos em que isso for necessário, é preciso enviar a peça com defeito à HP dentro do período determinado, normalmente cinco (5) dias úteis. A peça com defeito deve ser enviada com a documentação correspondente no material de transporte fornecido. Caso não o faça, a HP poderá cobrar a reposição. Para as peças de reparo feito pelo cliente, a HP paga todas as despesas de transporte e de devolução da peça e determina a transportadora/serviço postal a ser utilizado.

Para obter mais informações sobre o programa de reparo feito pelo cliente da HP, entre em contato com o fornecedor de serviços local. Para o programa norte-americano, visite o site da HP (<http://www.hp.com/go/selfrepair>).

## Serviço de garantia apenas para peças

A garantia limitada da HP pode incluir um serviço de garantia apenas para peças. Segundo os termos do serviço de garantia apenas para peças, a HP fornece as peças de reposição sem cobrar nenhuma taxa.

No caso desse serviço, a substituição de peças CSR é obrigatória. Se desejar que a HP substitua essas peças, serão cobradas as despesas de transporte e mão-de-obra do serviço.

## 顧客自己修理保証サービス

修理時間を短縮し、故障部品の交換における高い柔軟性を確保するために、HP製品には多数の顧客自己修理（CSR）部品があります。診断の際に、CSR部品を使用すれば修理ができるとHP（HPまたはHP正規保守代理店）が判断した場合、HPはその部品を直接、お客様に発送し、お客様に交換していただきます。CSR部品には以下の2通りがあります。

- 必須-顧客自己修理が必須の部品。当該部品について、もしもお客様がHPに交換作業を依頼される場合には、その修理サービスに関する交通費および人件費がお客様に請求されます。
- 任意-顧客自己修理が任意である部品。この部品も顧客自己修理用です。当該部品について、もしもお客様がHPに交換作業を依頼される場合には、お買い上げの製品に適用される保証サービス内容の範囲内においては、別途費用を負担していただくことなく保証サービスを受けることができます。

注：HP製品の一部の部品は、顧客自己修理用ではありません。製品の保証を継続するためには、HPまたはHP正規保守代理店による交換作業が必須となります。部品カタログには、当該部品が顧客自己修理除外品である旨が記載されています。

部品供給が可能な場合、地域によっては、CSR部品を翌営業日に届くように発送します。また、地域によっては、追加費用を負担いただくことにより同日または4時間以内に届くように発送することも可能な場合があります。サポートが必要なときは、HPの修理受付窓口にご電話いただければ、技術者が電話でアドバイスします。交換用のCSR部品または同梱物には、故障部品をHPに返送する必要があるかどうかが表示されています。故障部品をHPに返送する必要がある場合は、指定期限内（通常は5営業日以内）に故障部品をHPに返送してください。故障部品を返送する場合は、届いた時の梱包箱に関連書類とともに入れてください。故障部品を返送しない場合、HPから部品費用が請求されます。顧客自己修理の際には、HPは送料および部品返送費を全額負担し、使用する宅配便会社や運送会社を指定します。

## 部品のみ保証サービス

HP保証サービスには、部品のみ保証サービスが適用される場合があります。このサービスでは、交換部品は無償で提供されます。

部品のみ保証サービスにおいては、CSR部品をお客様により交換作業していただくことが必須となります。当該部品について、もしもお客様がHPに交換作業を依頼される場合には、その修理サービスに関する交通費および人件費はお客様の負担となります。

# 客户自行维修

HP 产品提供许多客户自行维修 (CSR) 部件，以尽可能缩短维修时间和在更换缺陷部件方面提供更大的灵活性。如果在诊断期间 HP（或 HP 服务提供商或服务合作伙伴）确定可以通过使用 CSR 部件完成维修，HP 将直接把该部件发送给您进行更换。有两类 CSR 部件：

- **强制性的** — 要求客户必须自行维修的部件。如果您请求 HP 更换这些部件，则必须为该服务支付差旅费和人工费用。
- **可选的** — 客户可以选择是否自行维修的部件。这些部件也是为客户自行维修设计的。不过，如果您要求 HP 为您更换这些部件，则根据为您的产品指定的保修服务类型，HP 可能收取或不再收取任何附加费用。

**注：**某些 HP 部件的设计并未考虑客户自行维修。为了满足客户保修的需要，HP 要求授权服务提供商更换相关部件。这些部件在部件图解目录中标记为“否”。

CSR 部件将在下一个工作日发运（取决于备货情况和允许的地理范围）。在允许的地理范围内，可在当天或四小时内发运，但要收取额外费用。如果需要帮助，您可以致电 HP 技术支持中心，将会有技术人员通过电话为您提供帮助。HP 会在随更换的 CSR 部件发运的材料中指明是否必须将有缺陷的部件返还给 HP。如果要求您将有缺陷的部件返还给 HP，那么您必须在规定期限内（通常是五 (5) 个工作日）将缺陷部件发给 HP。有缺陷的部件必须随所提供的发运材料中的相关文件一起返还。如果未能送还有缺陷的部件，HP 可能会要求您支付更换费用。客户自行维修时，HP 将承担所有相关运输和部件返回费用，并指定快递商/承运商。

有关 HP 客户自行维修计划的详细信息，请与您当地的服务提供商联系。有关北美地区的计划，请访问 HP 网站 (<http://www.hp.com/go/selfrepair>)。

## 仅部件保修服务

您的 HP 有限保修服务可能涉及仅部件保修服务。根据仅部件保修服务条款的规定，HP 将免费提供更换的部件。

仅部件保修服务要求进行 CSR 部件更换。如果您请求 HP 更换这些部件，则必须为该服务支付差旅费和人工费用。

# 客戶自行維修

HP 產品設計了許多「客戶自行維修」(CSR) 的零件以減少維修時間，並且使得更換瑕疵零件時能有更大的彈性。如果在診斷期間 HP (或 HP 服務供應商或維修夥伴) 辨認出此項維修工作可以藉由使用 CSR 零件來完成，則 HP 將直接寄送該零件給您作更換。CSR 零件分為兩種類別：

- **強制的** — 客戶自行維修所使用的零件是強制性的。如果您要求 HP 更換這些零件，HP 將會向您收取此服務所需的外出費用與勞動成本。
- **選購的** — 客戶自行維修所使用的零件是選購的。這些零件也設計用於客戶自行維修之用。不過，如果您要求 HP 為您更換，則可能需要也可能不需要負擔額外的費用，端視針對此產品指定的保固服務類型而定。

**備註：**某些 HP 零件沒有消費者可自行維修的設計。為符合客戶保固，HP 需要授權的服務供應商更換零件。這些零件在圖示的零件目錄中，被標示為「否」。

基於材料取得及環境允許的情況下，CSR 零件將於下一個工作日以快遞寄送。在環境的允許下當天或四小時內送達，則可能需要額外的費用。若您需要協助，可致電「HP 技術支援中心」，會有一位技術人員透過電話來協助您。不論損壞的零件是否必須退回，HP 皆會在與 CSR 替換零件一起運送的材料中註明。若要將損壞的零件退回 HP，您必須在指定的一段時間內（通常為五 (5) 個工作天），將損壞的零件寄回 HP。損壞的零件必須與寄送資料中隨附的相關技術文件一併退還。如果無法退還損壞的零件，HP 可能要向您收取替換費用。針對客戶自行維修情形，HP 將負責所有運費及零件退還費用並指定使用何家快遞/貨運公司。

如需 HP 的「客戶自行維修」方案詳細資訊，請連絡您當地的服務供應商。至於北美方案，請參閱 HP 網站 (<http://www.hp.com/go/selfrepair>)。

## 僅限零件的保固服務

您的「HP 有限保固」可能包含僅限零件的保固服務。在僅限零件的保固服務情況下，HP 將免費提供替換零件。

針對僅限零件的保固服務，CSR 零件替換是強制性的。如果您要求 HP 更換這些零件，HP 將會向您收取此服務所需的外出費用與勞動成本。

## 고객 셀프 수리

HP 제품은 수리 시간을 최소화하고 결함이 있는 부품 교체 시 더욱 융통성을 발휘할 수 있도록 하기 위해 고객 셀프 수리(CSR) 부품을 다량 사용하여 설계되었습니다. 진단 기간 동안 HP(또는 HP 서비스 공급업체 또는 서비스 협력업체)에서 CSR 부품을 사용하여 수리가 가능하다고 판단되면 HP는 해당 부품을 바로 사용자에게 보내어 사용자가 교체할 수 있도록 합니다. CSR 부품에는 두 가지 종류가 있습니다.

- **고객 셀프 수리가 의무 사항인 필수 부품.** 사용자가 HP에 이 부품의 교체를 요청할 경우 이 서비스에 대한 출장비 및 작업비가 청구됩니다.
- **고객 셀프 수리가 선택 사항인 부품.** 이 부품들도 고객 셀프 수리가 가능하도록 설계되었습니다. 하지만 사용자가 HP에 이 부품의 교체를 요청할 경우 사용자가 구입한 제품에 해당하는 보증 서비스 유형에 따라 추가 비용 없이 교체가 가능할 수 있습니다.

**참고:** 일부 HP 부품은 고객 셀프 수리가 불가능하도록 설계되었습니다. HP는 만족스러운 고객 보증을 위해 공인 서비스 제공업체를 통해 부품을 교체하도록 하고 있습니다. 이러한 부품들은 Illustrated Parts Catalog에 "No"라고 표시되어 있습니다.

CSR 부품은 재고 상태와 지리적 조건이 허용하는 경우 다음 영업일 납품이 가능하도록 배송이 이루어집니다. 지리적 조건이 허용하는 경우 추가 비용이 청구되는 조건으로 당일 또는 4시간 배송이 가능할 수도 있습니다. 도움이 필요하시면 HP 기술 지원 센터로 전화하십시오. 전문 기술자가 전화로 도움을 줄 것입니다. HP는 결함이 발생한 부품을 HP로 반환해야 하는지 여부를 CSR 교체 부품과 함께 배송된 자료에 지정합니다. 결함이 발생한 부품을 HP로 반환해야 하는 경우에는 지정된 기간 내(통상 영업일 기준 5일)에 HP로 반환해야 합니다. 이 때 결함이 발생한 부품은 제공된 포장 재료에 넣어 관련 설명서와 함께 반환해야 합니다. 결함이 발생한 부품을 반환하지 않는 경우 HP가 교체 부품에 대해 비용을 청구할 수 있습니다. 고객 셀프 수리의 경우, HP는 모든 운송 및 부품 반환 비용을 부담하며 이용할 운송업체 및 택배 서비스를 결정합니다.

HP 고객 셀프 수리 프로그램에 대한 자세한 내용은 가까운 서비스 제공업체에 문의하십시오. 북미 지역의 프로그램에 대해서는 HP 웹 사이트(<http://www.hp.com/go/selfrepair>)를 참조하십시오.

## 부품 제공 보증 서비스

HP 제한 보증에는 부품 제공 보증 서비스가 포함될 수 있습니다. 이러한 경우 HP는 부품 제공 보증 서비스의 조건에 따라 교체 부품만을 무료로 제공합니다.

부품 제공 보증 서비스 제공 시 CSR 부품 교체는 의무 사항입니다. 사용자가 HP에 이 부품의 교체를 요청할 경우 이 서비스에 대한 출장비 및 작업비가 청구됩니다.



# Illustrated parts catalog

## Server blade components

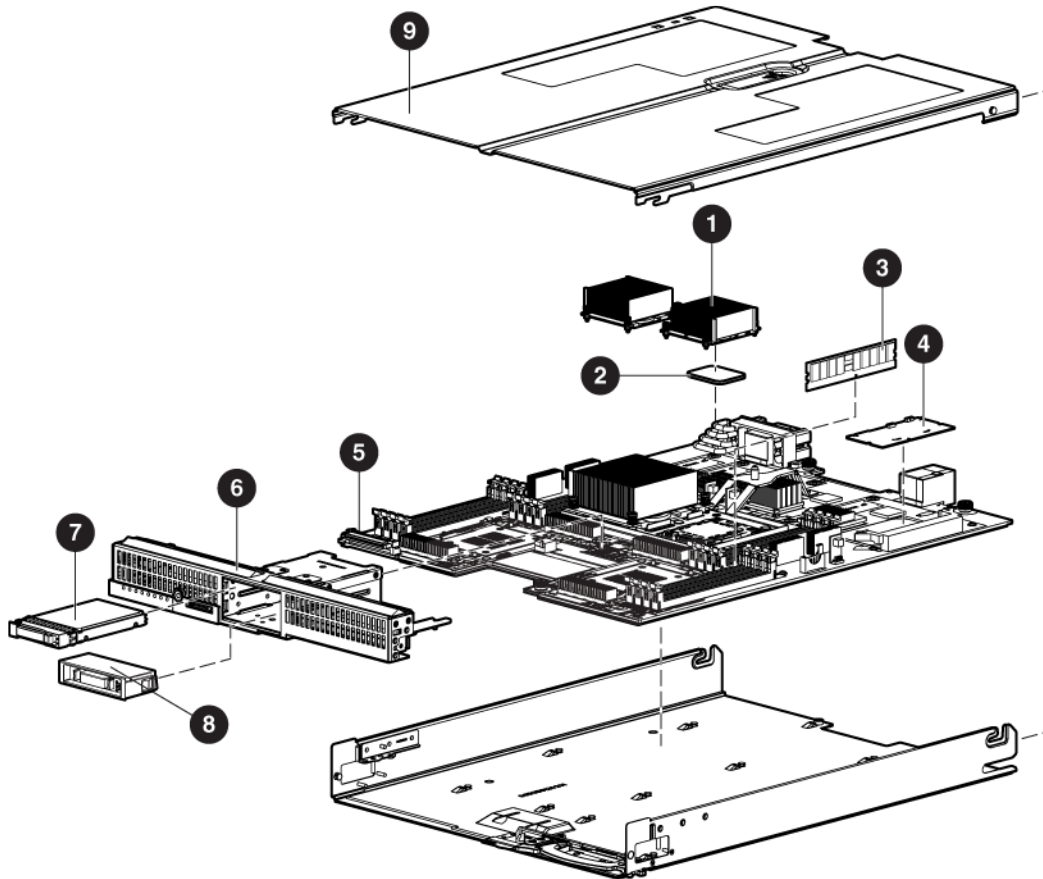

Item	Description	Spare part number	Customer self repair (on page 5)
1	Heatsink	436380-001	Optional <sup>2</sup>
2	Processor	—	—
	a) 1.9-GHz AMD Opteron™ Model 8347 HE* **	457127-001	Optional <sup>2</sup>
	b) 2.2-GHz AMD Opteron™ Model 8354* **	448404-001	Optional <sup>2</sup>
	c) 2.3-GHz AMD Opteron™ Model 8356* **	448405-001	Optional <sup>2</sup>
	d) 2.3-GHz AMD Opteron™ Model 8376 HE* **	518005-001	Optional <sup>2</sup>
	e) 2.6-GHz AMD Opteron™ Model 8382* **	508592-001	Optional <sup>2</sup>
	f) 2.7-GHz AMD Opteron™ Model 8384* **	508593-001	Optional <sup>2</sup>
3	DIMMs	—	—
	a) 512-MB, PC2-5300 DIMM	416355-001	Mandatory <sup>1</sup>



Item	Description	Spare part number	Customer self repair (on page 5)
	b) 1-GB, PC2-5300 DIMM*	416356-001	Mandatory <sup>1</sup>
	c) 2-GB, PC2-5300 DIMM*	432668-001	Mandatory <sup>1</sup>
	d) 2-GB, PC2-5300, low-power, registered DIMM*	416357-001	Mandatory <sup>1</sup>
	e) 2-GB, PC2- 5300, DDR2 2x1GB, low power DIMM, single rank kit*	488608-001	Mandatory <sup>1</sup>
	f) 2-GB, PC2-6400, DDR2 2x1GB DIMM kit*	501156-001	Mandatory <sup>1</sup>
	g) 4-GB, PC2-5300 DIMM*	432670-001	Mandatory <sup>1</sup>
	h) 4-GB, PC2-5300, low-power, registered DIMM (RoHS)*	487945-001	Mandatory <sup>1</sup>
	i) 4-GB, PC2-6400, DDR2 2x2GB DIMM kit*	501157-001	Mandatory <sup>1</sup>
	j) 4-GB, PC2-6400 4x2GB DIMM*	501158-001	Mandatory <sup>1</sup>
	k) 8-GB, PC2-5300 DIMM*	432671-001	Mandatory <sup>1</sup>
	l) 8-GB, PC2-6400, DDR2 2x4GB DIMM, low power kit*	504589-001	Mandatory <sup>1</sup>
4	Battery-backed write cache components	—	—
	a) HP Smart Array E200i Controller cache module, 64-MB	412800-001	Mandatory <sup>1</sup>
	b) HP Smart Array E200i Controller cache module, 128-MB*	351518-001	Mandatory <sup>1</sup>
	c) HP Smart Array E200i Controller battery pack*	307132-001	Mandatory <sup>1</sup>
5	System board	450086-001	Optional <sup>2</sup>
6	Front panel/hard drive cage assembly with front panel LED assembly	481417-001	Mandatory <sup>1</sup>
7	Hard drives	—	—
	a) 36-GB, 3G, SAS, SFF, 10,000-rpm	376596-001	Mandatory <sup>1</sup>
	b) 36-GB, 3G, SAS, SFF, 15,000-rpm*	432322-001	Mandatory <sup>1</sup>
	c) 36-GB, 3G, SAS, SFF, 15,000-rpm, dual-port*	418397-001	Mandatory <sup>1</sup>
	d) 60-GB, 1.5G, SATA, SFF, 5,400-rpm*	405419-001	Mandatory <sup>1</sup>
	e) 72-GB, 3G, SAS, SFF, 10,000-rpm*	434916-001	Mandatory <sup>1</sup>
	f) 72-GB, 3G, SAS, SFF, 10,000-rpm, dual-port*	389346-001	Mandatory <sup>1</sup>
	g) 72-GB, 3G, SAS, SFF, 15,000-rpm*	432321-001	Mandatory <sup>1</sup>
	h) 72-GB, 3G, SAS, SFF, 15,000-rpm, dual-port*	418398-001	Mandatory <sup>1</sup>
	i) 120-GB, 1.5G, SATA, SFF, 5,400-rpm*	431908-001	Mandatory <sup>1</sup>
	j) 146-GB, 3G, SAS, SFF, 10,000-rpm*	432320-001	Mandatory <sup>1</sup>
	k) 146-GB, 3G, SAS, SFF, 10,000-rpm, dual-port*	418399-001	Mandatory <sup>1</sup>
	l) 250-GB, 2.5G, SATA, SFF, 5,400-rpm*	460426-001	Mandatory <sup>1</sup>
	m) 300-GB, 2.5G, SAS, SFF, 10,000-rpm*	493083-001	Mandatory <sup>1</sup>
8	Hard drive blank	392613-001	Mandatory <sup>1</sup>
9	Access panel	483410-001	Mandatory <sup>1</sup>
10	Hard drive backplane*	436377-001	Optional <sup>2</sup>

Item	Description	Spare part number	Customer self repair (on page 5)
11	System battery, lithium, 3V*	234556-001	Mandatory <sup>1</sup>
12	SAS cable*	439329-001	Mandatory <sup>1</sup>
13	HP c-Class Blade SUV Cable*	416003-001	Mandatory <sup>1</sup>
14	Mezzanine card options*	—	—
	a) Emulex LPe1105-HP 4Gb FC HBA for HP c-Class BladeSystem	405921-001	Mandatory <sup>1</sup>
	b) QLogic QMH2462 4Gb FC HBA for HP c-Class BladeSystem	405920-001	Mandatory <sup>1</sup>
	c) HP NC325m PCI Express Quad Port Gigabit Server Adapter for c-Class BladeSystem	436011-001	Mandatory <sup>1</sup>
	d) HP NC326m PCI Express Dual Port 1Gb Server Adapter for c-Class BladeSystem	419330-001	Mandatory <sup>1</sup>
	e) HP NC360m HBA for c-Class BladeSystem	448068-001	Mandatory <sup>1</sup>
	f) HP NC364m Quad Port 1GbE BL-c Adapter	448066-001	Mandatory <sup>1</sup>
	g) HP NC373m PCI Express Dual Port Multifunction Gigabit Server Adapter for c-Class BladeSystem	430548-001	Mandatory <sup>1</sup>
	h) HP PCIe Mezzanine Pass-thru card*	436010-011	Mandatory <sup>1</sup>
	i) HP NC512m Dual Port 10GbE Multifunction BL-c Adapter	448515-001	Mandatory <sup>1</sup>
	j) HP NC382m PCI Express Dual-Port Multifunction Gigabit Server Adapter	462748-001	Mandatory <sup>1</sup>
	k) HP NC532m Dual-Port 10GbE Multifunction BL-c Adapter	466308-001	Mandatory <sup>1</sup>
	l) QLogic QMH4062 1GbE iSCSI Adapter for HP c-Class BladeSystem	488081-001	Mandatory <sup>1</sup>
15	Handle kit*	434104-001	Mandatory <sup>1</sup>
	a) Server blade handle	—	—
	b) Release button	—	—
	c) Server blade handle screw, Phillips head	—	—
	d) Release button screws, T-15 (2)	—	—
	e) Server blade handle nut	—	—
16	Hardware and plastics kit*	436381-001	Mandatory <sup>1</sup>
	a) Processor blank	—	—
	b) Device bay blank coupler	—	—
	c) Connector cover, enclosure connector 1	—	—
	d) Connector cover, enclosure connector 2	—	—
	e) Rear access panel support	—	—
	f) DIMM baffle, front	—	—
	g) DIMM baffle, rear	—	—

\* Not shown

\*\*Do not mix processors with different model numbers, speeds, cache sizes, or power consumption.

<sup>1</sup>Mandatory—Parts for which customer self repair is mandatory. If you request HP to replace these parts, you will be charged for the travel and labor costs of this service.

<sup>2</sup>Optional—Parts for which customer self repair is optional. These parts are also designed for customer self repair. If, however, you require that HP replace them for you, there may or may not be additional charges, depending on the type of warranty service designated for your product.

<sup>3</sup>No—Some HP parts are not designed for customer self repair. In order to satisfy the customer warranty, HP requires that an authorized service provider replace the part. These parts are identified as "No" in the Illustrated Parts Catalog.

<sup>1</sup>Mandatory: Obligatoire—Pièces pour lesquelles la réparation par le client est obligatoire. Si vous demandez à HP de remplacer ces pièces, les coûts de déplacement et main d'œuvre du service vous seront facturés.

<sup>2</sup>Optional: Facultatif—Pièces pour lesquelles la réparation par le client est facultative. Ces pièces sont également conçues pour permettre au client d'effectuer lui-même la réparation. Toutefois, si vous demandez à HP de remplacer ces pièces, l'intervention peut ou non vous être facturée, selon le type de garantie applicable à votre produit.

<sup>3</sup>No: Non—Certaines pièces HP ne sont pas conçues pour permettre au client d'effectuer lui-même la réparation. Pour que la garantie puisse s'appliquer, HP exige que le remplacement de la pièce soit effectué par un Mainteneur Agréé. Ces pièces sont identifiées par la mention "Non" dans le Catalogue illustré.

<sup>1</sup>Mandatory: Obbligatorie—Parti che devono essere necessariamente riparate dal cliente. Se il cliente ne affida la riparazione ad HP, deve sostenere le spese di spedizione e di manodopera per il servizio.

<sup>2</sup>Optional: Opzionali—Parti la cui riparazione da parte del cliente è facoltativa. Si tratta comunque di componenti progettati per questo scopo. Se tuttavia il cliente ne richiede la sostituzione ad HP, potrebbe dover sostenere spese aggiuntive a seconda del tipo di garanzia previsto per il prodotto.

<sup>3</sup>No: Non CSR—Alcuni componenti HP non sono progettati per la riparazione da parte del cliente. Per rispettare la garanzia, HP richiede che queste parti siano sostituite da un centro di assistenza autorizzato. Tali parti sono identificate da un "No" nel Catalogo illustrato dei componenti.

<sup>1</sup>Mandatory: Zwingend—Teile, die im Rahmen des Customer Self Repair Programms ersetzt werden müssen. Wenn Sie diese Teile von HP ersetzen lassen, werden Ihnen die Versand- und Arbeitskosten für diesen Service berechnet.

<sup>2</sup>Optional: Optional—Teile, für die das Customer Self Repair-Verfahren optional ist. Diese Teile sind auch für Customer Self Repair ausgelegt. Wenn Sie jedoch den Austausch dieser Teile von HP vornehmen lassen möchten, können bei diesem Service je nach den für Ihr Produkt vorgesehenen Garantiebedingungen zusätzliche Kosten anfallen.

<sup>3</sup>No: Kein—Einige Teile sind nicht für Customer Self Repair ausgelegt. Um den Garantieanspruch des Kunden zu erfüllen, muss das Teil von einem HP Servicepartner ersetzt werden. Im illustrierten Teilekatalog sind diese Teile mit „No“ bzw. „Nein“ gekennzeichnet.

<sup>1</sup>Mandatory: Obligatorio—componentes para los que la reparación por parte del usuario es obligatoria. Si solicita a HP que realice la sustitución de estos componentes, tendrá que hacerse cargo de los gastos de desplazamiento y de mano de obra de dicho servicio.

<sup>2</sup>Optional: Opcional— componentes para los que la reparación por parte del usuario es opcional. Estos componentes también están diseñados para que puedan ser reparados por el usuario. Sin embargo, si precisa que HP realice su sustitución, puede o no conllevar costes adicionales, dependiendo del tipo de servicio de garantía correspondiente al producto.

<sup>3</sup>No: No—Algunos componentes no están diseñados para que puedan ser reparados por el usuario. Para que el usuario haga valer su garantía, HP pone como condición que un proveedor de servicios autorizado realice la sustitución de estos componentes. Dichos componentes se identifican con la palabra "No" en el catálogo ilustrado de componentes.

<sup>1</sup>Mandatory: Verplicht—Onderdelen waarvoor Customer Self Repair verplicht is. Als u HP verzoekt deze onderdelen te vervangen, komen de reiskosten en het arbeidsloon voor uw rekening.

<sup>2</sup>Optional: Optioneel—Onderdelen waarvoor reparatie door de klant optioneel is. Ook deze onderdelen zijn ontworpen voor reparatie door de klant. Als u echter HP verzoekt deze onderdelen voor u te vervangen, kunnen daarvoor extra kosten in rekening worden gebracht, afhankelijk van het type garantieservice voor het product.

<sup>3</sup>No: Nee—Sommige HP onderdelen zijn niet ontwikkeld voor reparatie door de klant. In verband met de garantievoorwaarden moet het onderdeel door een geautoriseerde Service Partner worden vervangen. Deze onderdelen worden in de geïllustreerde onderdelencatalogus aangemerkt met "Nee".

<sup>1</sup>Mandatory: Obrigatória—Peças cujo reparo feito pelo cliente é obrigatório. Se desejar que a HP substitua essas peças, serão cobradas as despesas de transporte e mão-de-obra do serviço.

<sup>2</sup>Optional: Opcional—Peças cujo reparo feito pelo cliente é opcional. Essas peças também são projetadas para o reparo feito pelo cliente. No entanto, se desejar que a HP as substitua, pode haver ou não a cobrança de taxa adicional, dependendo do tipo de serviço de garantia destinado ao produto.

<sup>3</sup>No: Nenhuma—Algumas peças da HP não são projetadas para o reparo feito pelo cliente. A fim de cumprir a garantia do cliente, a HP exige que um técnico autorizado substitua a peça. Essas peças estão identificadas com a marca “No” (Não), no catálogo de peças ilustrado.

<sup>1</sup>Mandatory: 必須・顧客自己修理が必須の部品。当該部品について、もしもお客様がHPに交換作業を依頼される場合には、その修理サービスに関する交通費および人件費がお客様に請求されます。

<sup>2</sup>Optional: 任意・顧客自己修理が任意である部品。この部品も顧客自己修理用です。当該部品について、もしもお客様がHPに交換作業を依頼される場合には、お買い上げの製品に適用される保証サービス内容の範囲内においては、費用を負担していただくことなく保証サービスを受けることができます。

<sup>3</sup>No: 除外・HP製品の一部の部品は、顧客自己修理用ではありません。製品の保証を継続するためには、HPまたはHP正規保守代理店による交換作業が必須となります。部品カタログには、当該部品が顧客自己修理除外品である旨が記載されています。

<sup>1</sup>Mandatory: 强制性的 — 要求客户必须自行维修的部件。如果您请求 HP 更换这些部件，则必须为该服务支付差旅费和人工费用。

<sup>2</sup>Optional: 可选的 — 客户可以选择是否自行维修的部件。这些部件也是为客户自行维修设计的。不过，如果您要求 HP 为您更换这些部件，则根据为您的产品指定的保修服务类型，HP 可能收取或不再收取任何附加费用。

<sup>3</sup>No: 否 — 某些 HP 部件的设计并未考虑客户自行维修。为了满足客户保修的需要，HP 要求授权服务提供商更换相关部件。这些部件在部件图解目录中标记为“否”。

<sup>1</sup>Mandatory: 強制的 — 客戶自行維修所使用的零件是強制的。如果您要求 HP 更換這些零件，HP 將會向您收取此服務所需的外出費用與勞動成本。

<sup>2</sup>Optional: 選購的 — 客戶自行維修所使用的零件是選購的。這些零件也設計用於客戶自行維修之用。不過，如果您要求 HP 為您更換，則可能需要也可能不需要負擔額外的費用，端視針對此產品指定的保固服務類型而定。

<sup>3</sup>No: 否 — 某些 HP 零件沒有消費者可自行維修的設計。為符合客戶保固，HP 需要授權的服務供應商更換零件。這些零件在圖示的零件目錄中，被標示為「否」。

<sup>1</sup> Mandatory: 필수 — 고객 셀프 수리가 의무 사항인 필수 부품. 사용자가 HP에 이 부품의 교체를 요청할 경우 이 서비스에 대한 출장비 및 작업비가 청구됩니다.

<sup>2</sup> Optional: 옵션 — 고객 셀프 수리가 선택 사항인 부품. 이 부품들도 고객 셀프 수리가 가능하도록 설계되었습니다. 하지만 사용자가 HP에 이 부품의 교체를 요청할 경우 사용자가 구입한 제품에 해당하는 보증 서비스 유형에 따라 추가 비용 없이 교체가 가능할 수 있습니다.

<sup>3</sup> No: No — 고객 셀프 수리가 불가능하도록 설계된 HP 부품. 이 부품들은 고객 셀프 수리가 불가능하도록 설계되었습니다. HP는 고객 보증을 만족시키기 위해 공인 서비스 제공업체를 통해 부품을 교체하도록 하고 있습니다.

---

# Removal and replacement procedures

## Required tools

You need the following items for some procedures:

- T-15 Torx screwdriver
- Diagnostics Utility ("[Array Diagnostic Utility](#)" on page 54)

## Safety considerations

Before performing service procedures, review all the safety information.

### Preventing electrostatic discharge

To prevent damaging the system, be aware of the precautions you need to follow when setting up the system or handling parts. A discharge of static electricity from a finger or other conductor may damage system boards or other static-sensitive devices. This type of damage may reduce the life expectancy of the device.

To prevent electrostatic damage:

- Avoid hand contact by transporting and storing products in static-safe containers.
- Keep electrostatic-sensitive parts in their containers until they arrive at static-free workstations.
- Place parts on a grounded surface before removing them from their containers.
- Avoid touching pins, leads, or circuitry.
- Always be properly grounded when touching a static-sensitive component or assembly.

### Server blade warnings and cautions

- 
- ⚠ **WARNING:** To reduce the risk of shock or injury from high-current electrical energy, do not remove the server blade access panel and then install the server blade into the enclosure.

---

  - ⚠ **WARNING:** To reduce the risk of personal injury from hot surfaces, allow the drives and the internal system components to cool before touching them.

---

  - ⚠ **CAUTION:** Do not operate the server blade with the access panel removed. Operating the server blade in this manner results in improper airflow and improper cooling that can lead to thermal damage.

---

  - ⚠ **CAUTION:** When performing non-hot-plug operations, you must power down the server blade and/or the system. However, it may be necessary to leave the server blade powered up when performing other operations, such as hot-plug installations or troubleshooting.
-

## Symbols on equipment

The following symbols may be placed on equipment to indicate the presence of potentially hazardous conditions.

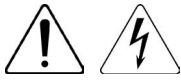

This symbol indicates the presence of hazardous energy circuits or electric shock hazards. Refer all servicing to qualified personnel.

**WARNING:** To reduce the risk of injury from electric shock hazards, do not open this enclosure. Refer all maintenance, upgrades, and servicing to qualified personnel.



This symbol indicates the presence of electric shock hazards. The area contains no user or field serviceable parts. Do not open for any reason.

**WARNING:** To reduce the risk of injury from electric shock hazards, do not open this enclosure.



This symbol on an RJ-45 receptacle indicates a network interface connection.

**WARNING:** To reduce the risk of electric shock, fire, or damage to the equipment, do not plug telephone or telecommunications connectors into this receptacle.

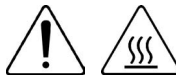

This symbol indicates the presence of a hot surface or hot component. If this surface is contacted, the potential for injury exists.

**WARNING:** To reduce the risk of injury from a hot component, allow the surface to cool before touching.



9.53 kg  
21.02 lb

This symbol indicates that the component exceeds the recommended weight for one individual to handle safely.

**WARNING:** To reduce the risk of personal injury or damage to the equipment, observe local occupational health and safety requirements and guidelines for manual material handling.



These symbols, on power supplies or systems, indicate that the equipment is supplied by multiple sources of power.

**WARNING:** To reduce the risk of injury from electric shock, remove all power cords to completely disconnect power from the system.

## Server blade preparation

To service any internal server blade component, power down the server blade and remove it from the enclosure.

### Power down the server blade

Before powering down the server blade for any upgrade or maintenance procedures, perform a backup of critical server data and programs.

Depending on the Onboard Administrator configuration, use one of the following methods to power down the server blade:

- Use a virtual power button selection through iLO 2.

This method initiates a controlled remote shutdown of applications and the OS before the server blade enters standby mode.

- Press and release the Power On/Standby button.  
This method initiates a controlled shutdown of applications and the OS before the server blade enters standby mode.
- Press and hold the Power On/Standby button for more than 4 seconds to force the server blade to enter standby mode.  
This method forces the server blade to enter standby mode without properly exiting applications and the OS. It provides an emergency shutdown method if an application stops responding.
- Execute one of the following commands using the Onboard Administrator CLI:  

```
poweroff server [bay number]
```

or

```
poweroff server [bay number] force
```

The first command initiates a controlled shutdown of applications and the OS before the server blade enters standby mode. The second form of the command forces the server blade to enter standby mode without exiting applications and the OS. This emergency method forces a shutdown if an application stops responding.
- Use the Onboard Administrator GUI to initiate a shutdown:
  - a. Select the **Enclosure Information** tab, and then select the **Overall** checkbox in the Device Bays item.
  - b. Initiate a shutdown from the Virtual Power menu:
    - Select **Momentary Press** to initiate a controlled shutdown of applications and the OS.
    - Select **Press and Hold** to initiate an emergency shutdown of applications and the OS.



---

**IMPORTANT:** When the server blade is in standby mode, auxiliary power is still being provided. To remove all power from the server blade, remove the server blade from the enclosure.

---

After initiating a virtual power down command, be sure that the server blade is in standby mode by observing that the system power LED is amber.

## Remove the server blade

1. Identify the proper server blade.
2. Power down the server blade (on page 22).

3. Remove the server blade.

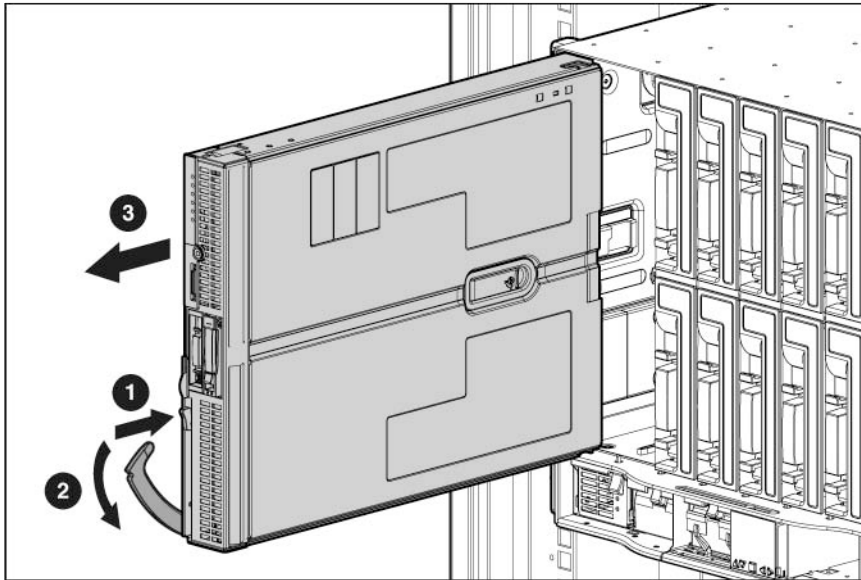

4. Place the server blade on a flat, level work surface.

- WARNING:** To reduce the risk of personal injury from hot surfaces, allow the drives and the internal system components to cool before touching them.
- CAUTION:** To prevent damage to electrical components, properly ground the server blade before beginning any installation procedure. Improper grounding can cause ESD.

## Access panel

To remove the component:

1. Power down the server blade (on page 22).
2. Remove the server blade (on page 23).
3. Lift the access panel latch and slide the access panel to the rear.
4. Remove the access panel.

- WARNING:** To reduce the risk of personal injury from hot surfaces, allow the drives and the internal system components to cool before touching them.
- CAUTION:** To prevent damage to electrical components, properly ground the server blade before beginning any installation procedure. Improper grounding can cause ESD.

To replace the component:

1. Place the access panel on top of the server blade with the hood latch open. Allow the panel to extend past the rear of the server blade approximately 0.8 cm (0.2 in).
2. Engage the anchoring pin with the corresponding hole in the latch.
3. Push down on the hood latch. The access panel slides to a closed position.



# Hard drive blank

Remove the component as indicated.

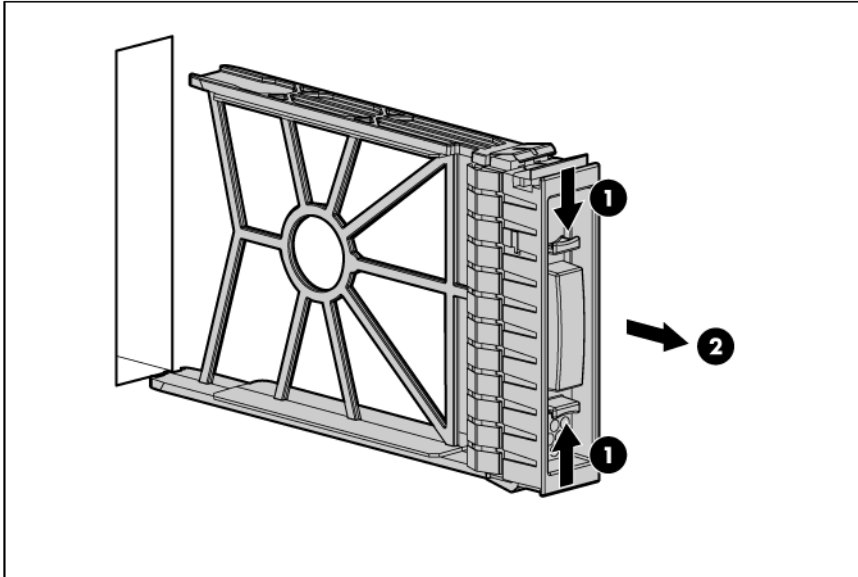

To replace the component, reverse the removal procedure.

# Hard drive

1. Determine the status of the hard drive from the hot-plug SAS hard drive LED combinations ("[SAS and SATA hard drive LED combinations](#)" on page 58).
2. Back up all server data.
3. Remove the hard drive.

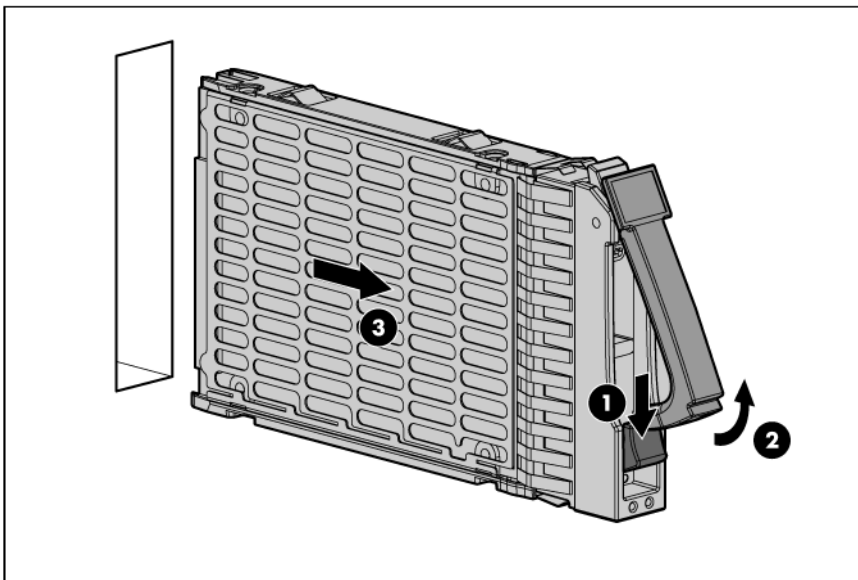

To replace the component, reverse the removal procedure.

# DIMM baffle

- △ **CAUTION:** To avoid damage to the server blade and the enclosure, install all DIMM baffles in the proper location after adding or replacing DIMMs. DIMM baffles that are missing or installed incorrectly can compromise server blade and enclosure cooling.

To remove the component:

1. Power down the server blade (on page 22).
2. Remove the server blade (on page 23).
3. Remove the access panel ("Access panel" on page 24).
4. Remove the DIMM baffle.

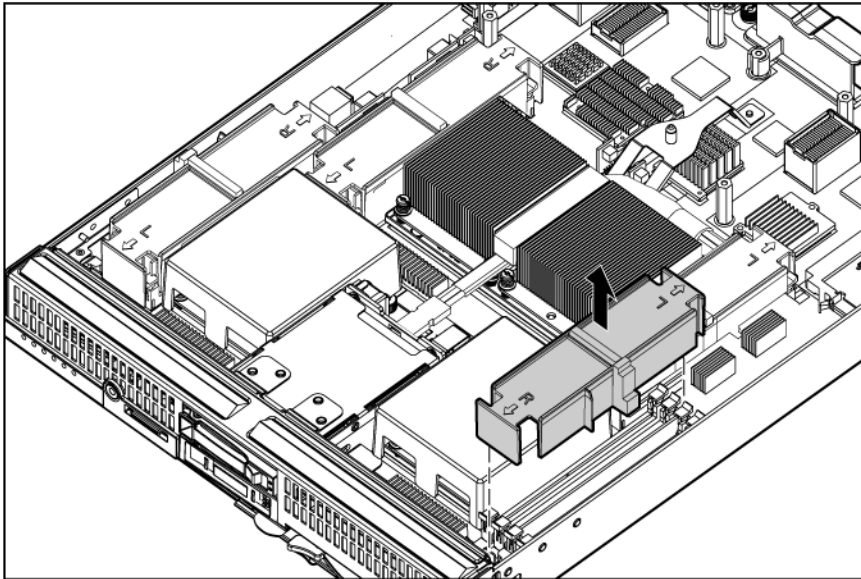

- △ **CAUTION:** To avoid damage to the server blade and the enclosure, install all DIMM baffles in the proper location after adding or replacing DIMMs. DIMM baffles that are missing or installed incorrectly can compromise server blade and enclosure cooling.

DIMM baffles for processor 1 and 2 memory banks have a single top gasket. DIMM baffles for processors 3 and 4 memory banks have a top and a side gasket.

To replace the component:

1. Install the DIMM baffles:
  - Install DIMM baffles for processor 1 and 3 memory banks with the R toward the front of the server blade.
  - Install DIMM baffles for processor 2 and 4 memory banks with the L toward the front of the server blade.
2. Install the access panel ("Access panel" on page 24).
3. Install the server blade.

## DIMMs

 **CAUTION:** Use only HP DIMMs. DIMMs from other sources may adversely affect data integrity.

To remove the component:

1. Power down the server blade (on page 22).
2. Remove the server blade (on page 23).
3. Remove the access panel ("Access panel" on page 24).
4. Remove all DIMM baffles ("DIMM baffle" on page 26).
5. Remove the DIMM.

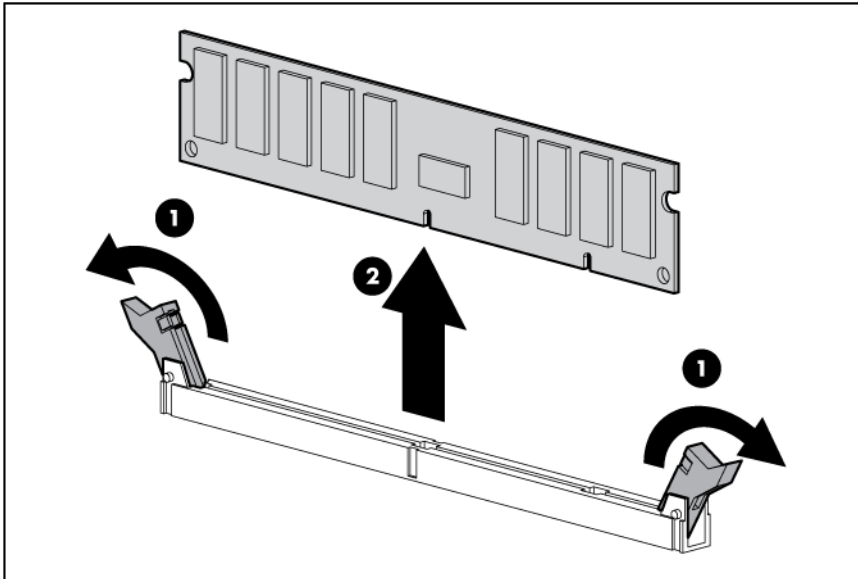

To replace the component:

1. Install the DIMM.
2. Install the DIMM baffle ("DIMM baffle" on page 26).
3. Install the access panel ("Access panel" on page 24).
4. Install the server blade.
5. Use RBSU to verify the configuration.

## Mezzanine card

Optional mezzanine cards enable network connectivity and provide Fibre Channel support. For mezzanine card locations, see the system board components (on page 59).

To remove the component:

1. Power down the server blade (on page 22).
2. Remove the server blade (on page 23).
3. Remove the access panel ("Access panel" on page 24).

4. Remove the mezzanine card.

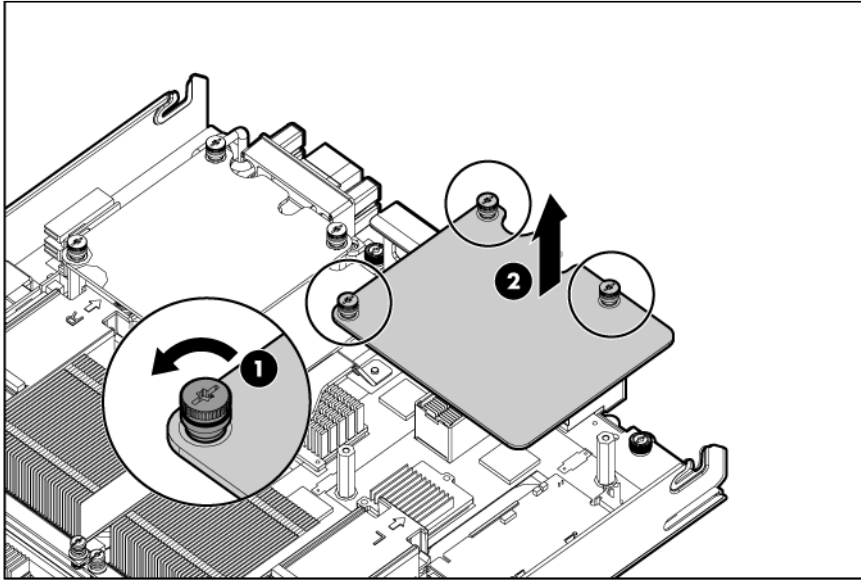

**CAUTION:** To prevent damage to the server blade, apply pressure over the mezzanine connector when installing the mezzanine card. Do not apply pressure to the edges of the card.

To replace the component, reverse the removal procedure.

## HP Smart Array E200i Controller cache module

To remove the component:

1. Power down the server blade (on page 22).
2. Remove the server blade (on page 23).
3. Remove the access panel ("Access panel" on page 24).
4. Remove the cache module.

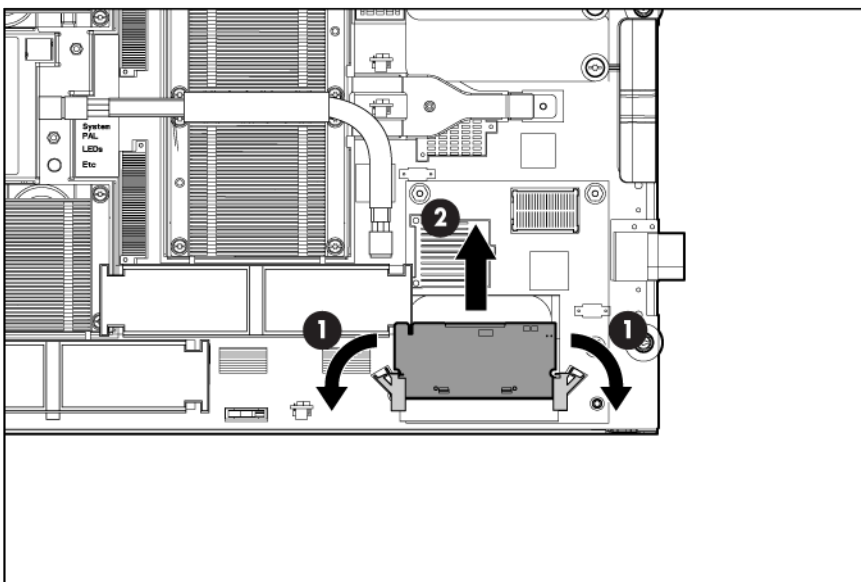

To replace the component, reverse the removal procedure.

## HP Smart Array E200i Controller cache module battery pack

To remove the component:

1. Power down the server blade (on page 22).
2. Remove the server blade (on page 23).
3. Remove the access panel ("Access panel" on page 24).
4. Remove the cache module ("HP Smart Array E200i Controller cache module" on page 28).
5. Remove the battery pack.

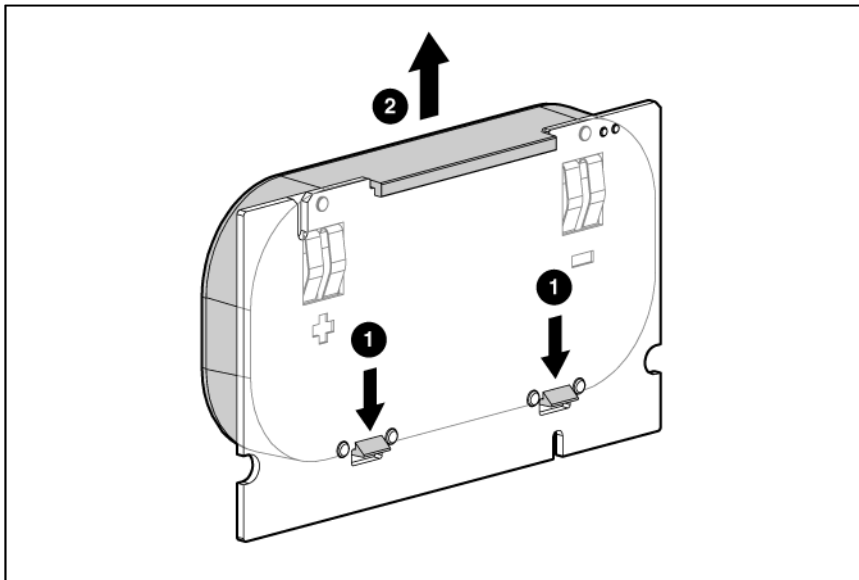

To replace the component, reverse the removal procedure.

## SAS cable

To remove the component:

1. Power down the server blade (on page 22).
2. Remove the server blade (on page 23).
3. Remove the access panel ("Access panel" on page 24).

4. Remove the SAS cable.

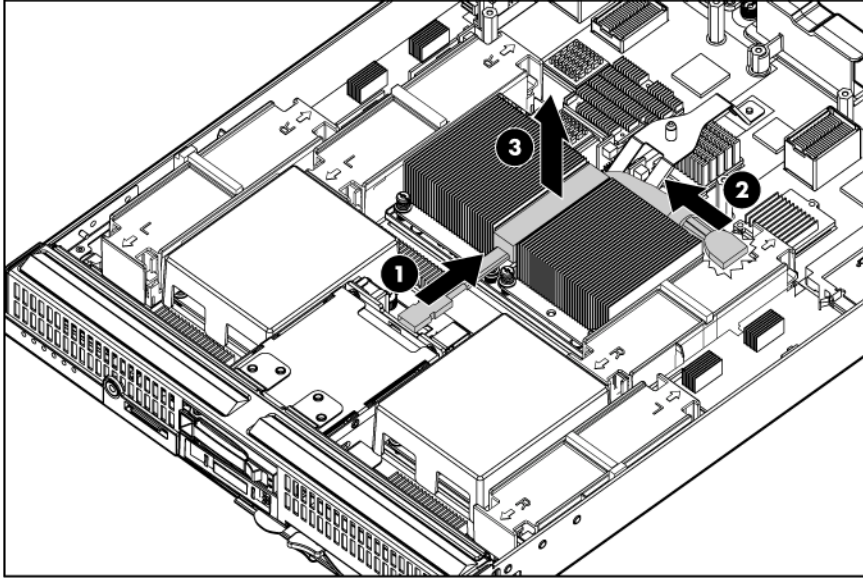

To replace the component, reverse the removal procedure.

## Hard drive backplane

To remove the component:

1. Power down the server blade (on page 22).
2. Remove the server blade (on page 23).

---

△ **CAUTION:** Remove all hard drives and hard drive blanks before removing the hard drive backplane.

---

3. Remove all hard drives ("Hard drive" on page 25).
4. Remove all hard drive blanks ("Hard drive blank" on page 25).
5. Remove the access panel ("Access panel" on page 24).
6. Disconnect the SAS cable.



7. Remove the hard drive backplane.

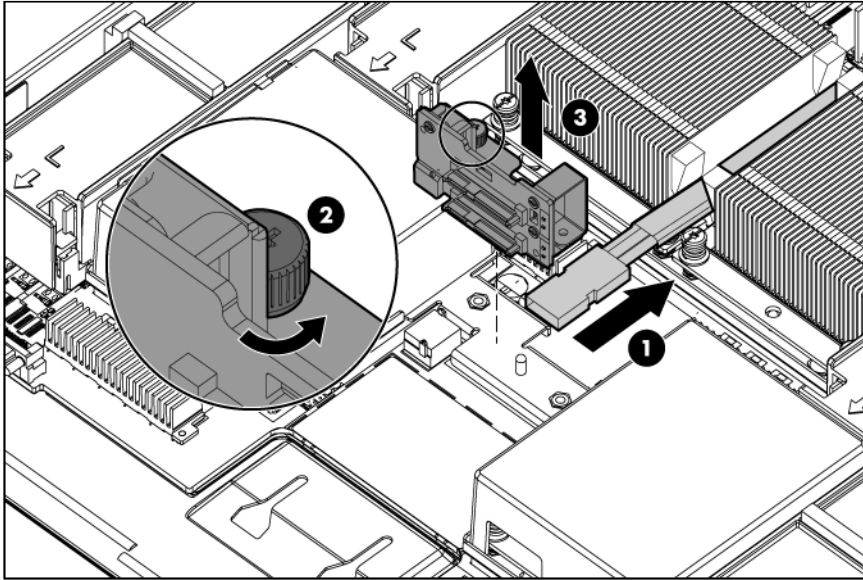

To replace the component, reverse the removal procedure.

## Front panel/hard drive cage assembly

To remove the component:

1. Power down the server blade (on page 22).
2. Remove the server blade (on page 23).
3. Remove the access panel ("Access panel" on page 24).
4. Remove all hard drives ("Hard drive" on page 25).
5. Remove all hard drive blanks ("Hard drive blank" on page 25).
6. Remove the front panel/hard drive cage assembly.

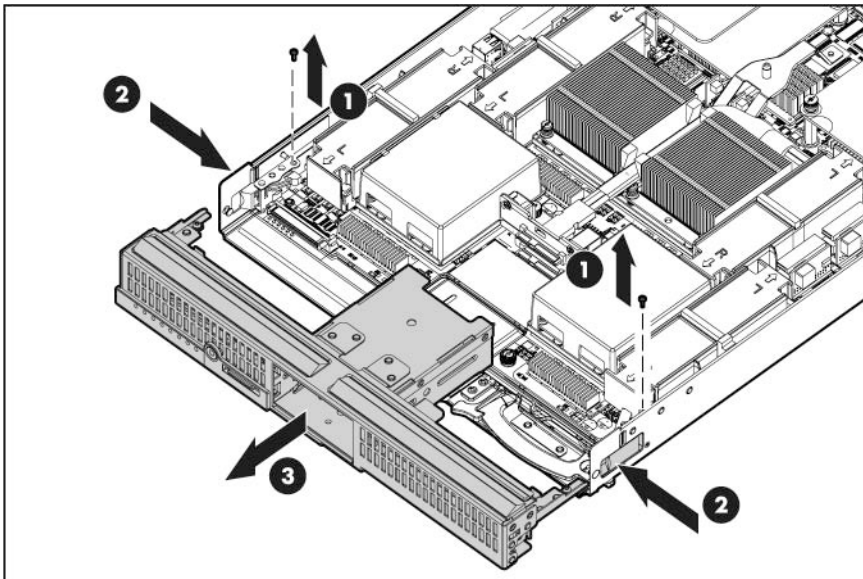

To replace the component, reverse the removal procedure.

# Server blade handle

To remove the component:

1. Power down the server blade (on page 22).
2. Remove the server blade (on page 23).
3. Remove the access panel ("Access panel" on page 24).
4. Remove all hard drives ("Hard drive" on page 25).
5. Remove all hard drive blanks ("Hard drive blank" on page 25).
6. Remove the front panel/hard drive cage assembly ("Front panel/hard drive cage assembly" on page 31).
7. Remove the server blade handle.

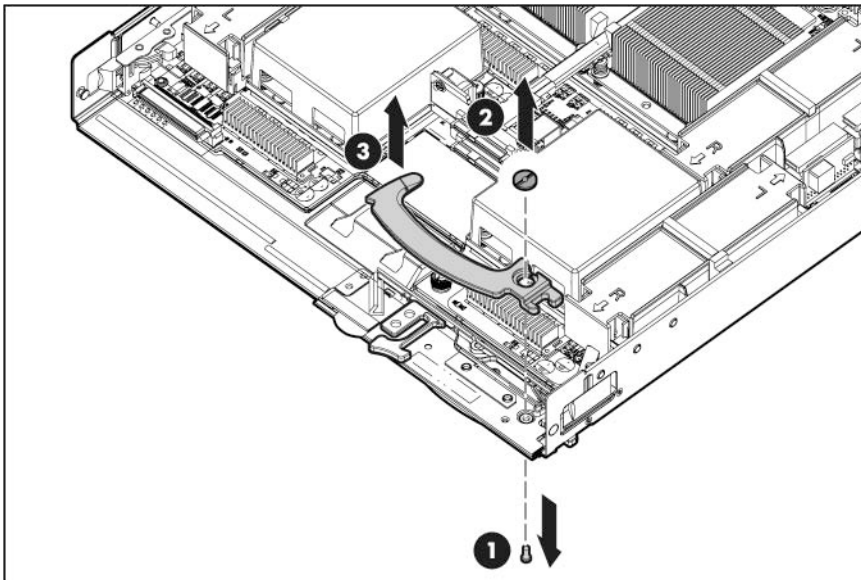

To replace the component, reverse the removal procedure.

# Release button

To remove the component:

1. Power down the server blade (on page 22).
2. Remove the server blade (on page 23).
3. Remove the access panel ("Access panel" on page 24).
4. Remove all hard drives ("Hard drive" on page 25).
5. Remove all hard drive blanks ("Hard drive blank" on page 25).
6. Remove the front panel/hard drive cage assembly ("Front panel/hard drive cage assembly" on page 31).



7. Remove the release button.

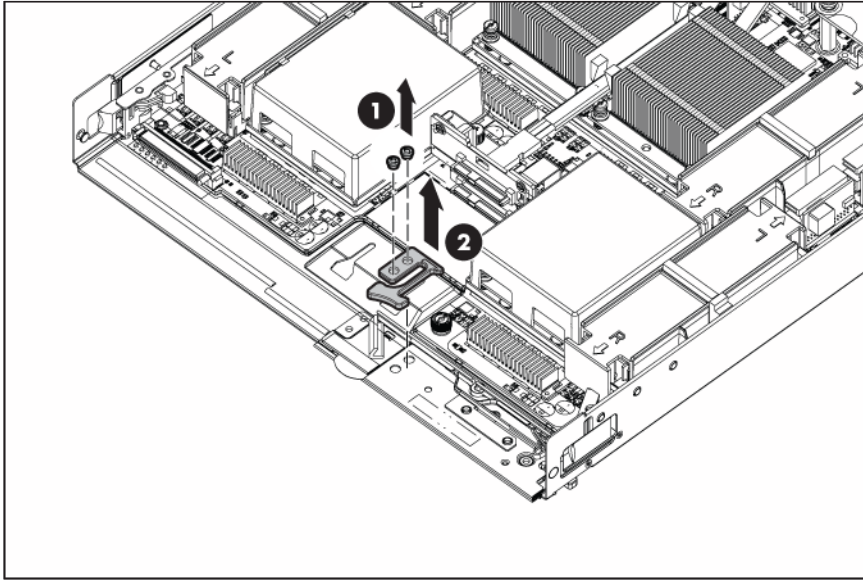

To replace the component, reverse the removal procedure.

## Heatsink



**IMPORTANT:** Do not install the air baffles on heatsinks for processors 3 and 4.

To remove the component:

1. Power down the server blade (on page 22).
2. Remove the server blade (on page 23).
3. Remove the access panel ("Access panel" on page 24).
4. Remove the SAS cable, if installed ("SAS cable" on page 29).
5. Remove the failed heatsink:

- Processor 3 or 4

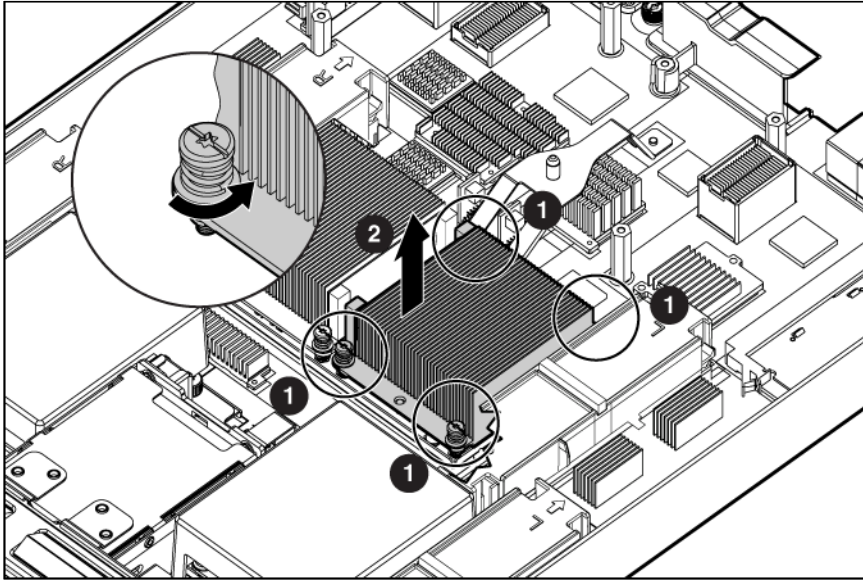

- Processor 1 or 2

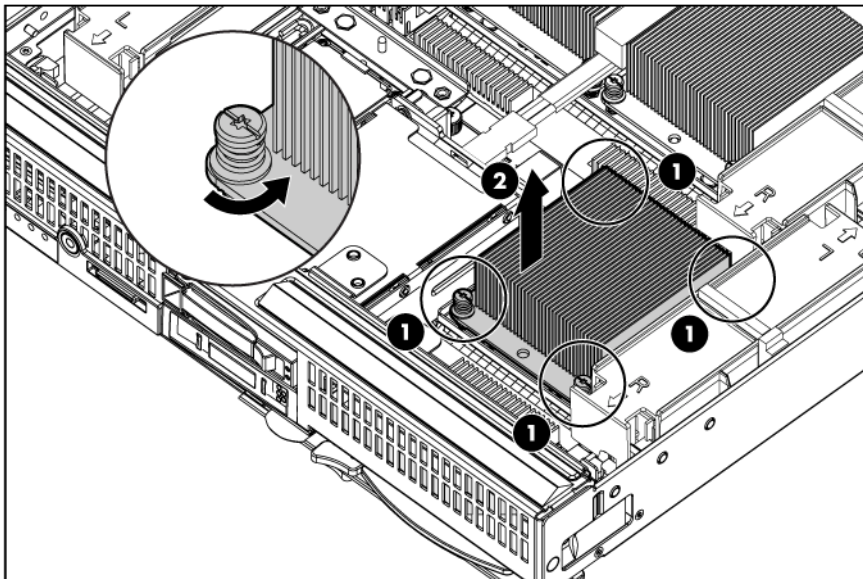

To replace the component:

1. Clean the old thermal grease from the processor with the alcohol swab. Allow the alcohol to evaporate before continuing.

2. Remove the thermal interface protective cover from the heatsink.

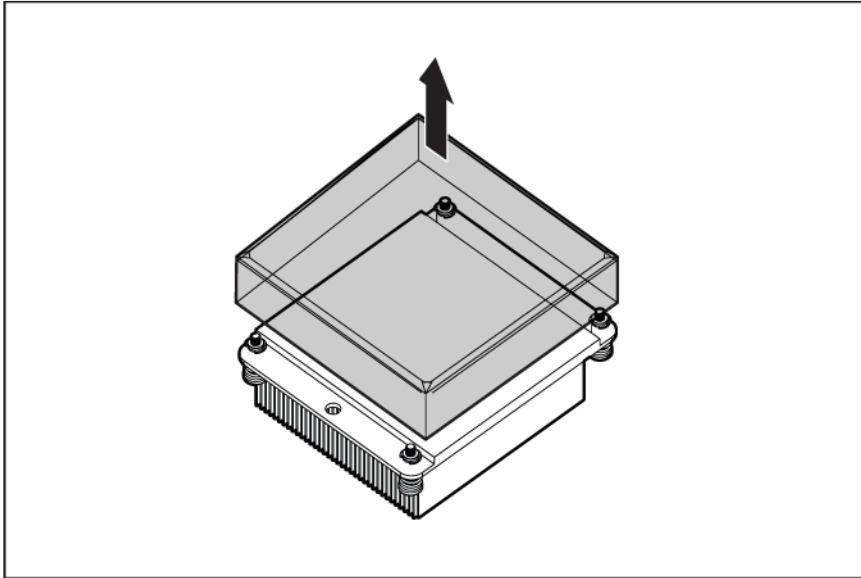

**IMPORTANT:** Do not install the air baffles on heatsinks for processors 3 and 4.

3. If the heatsink will be installed on processor 1 or 2, expose the adhesive and apply the air baffles to the side of the heatsink that will face the center of the server.

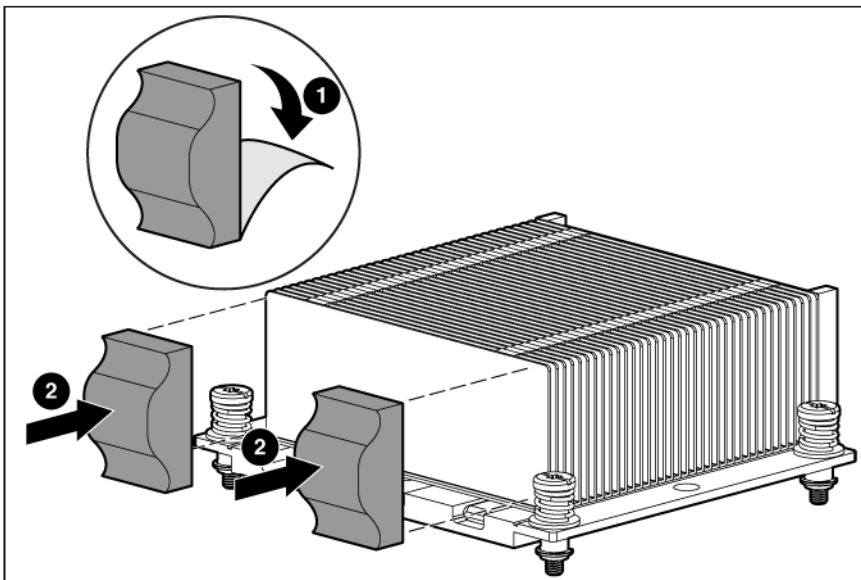

4. Align the holes in the heatsink with the guide pins on the processor cage.

- Processor 3 or 4

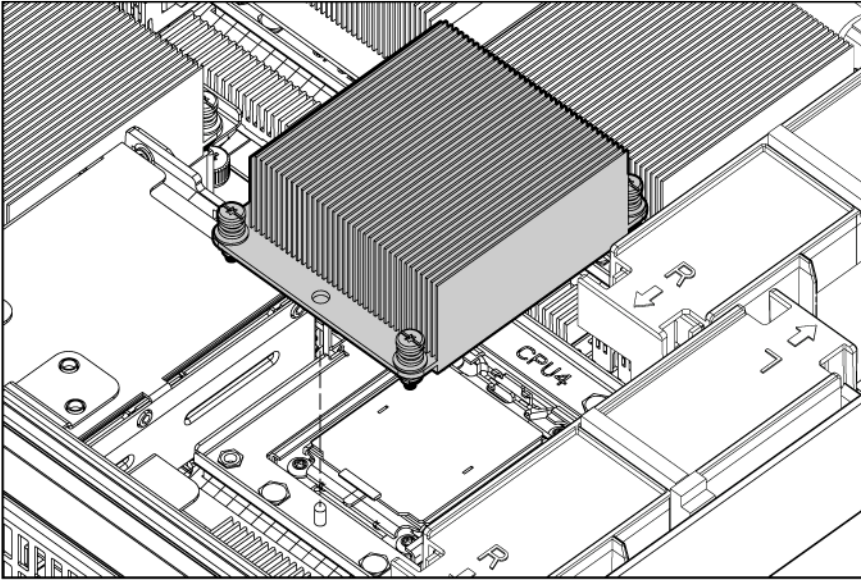

- Processor 1 or 2

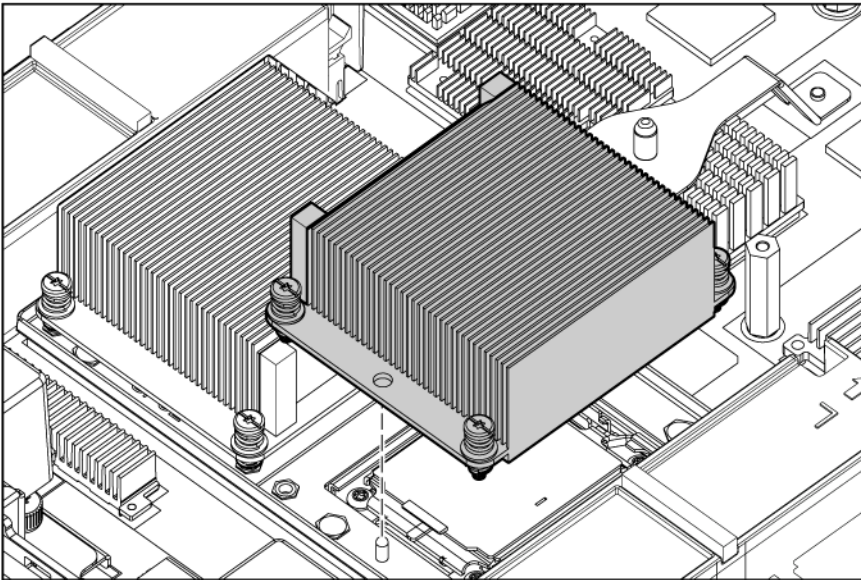

△ **CAUTION:** Heatsink retaining screws should be tightened in diagonally opposite pairs (in an "X" pattern).

5. Install the heatsink:



- Processor 3 or 4

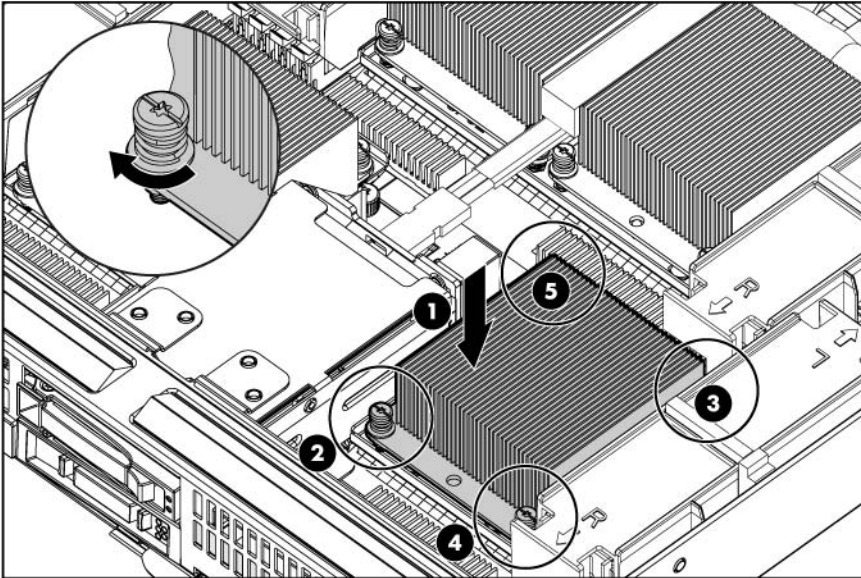

- Processor 1 or 2

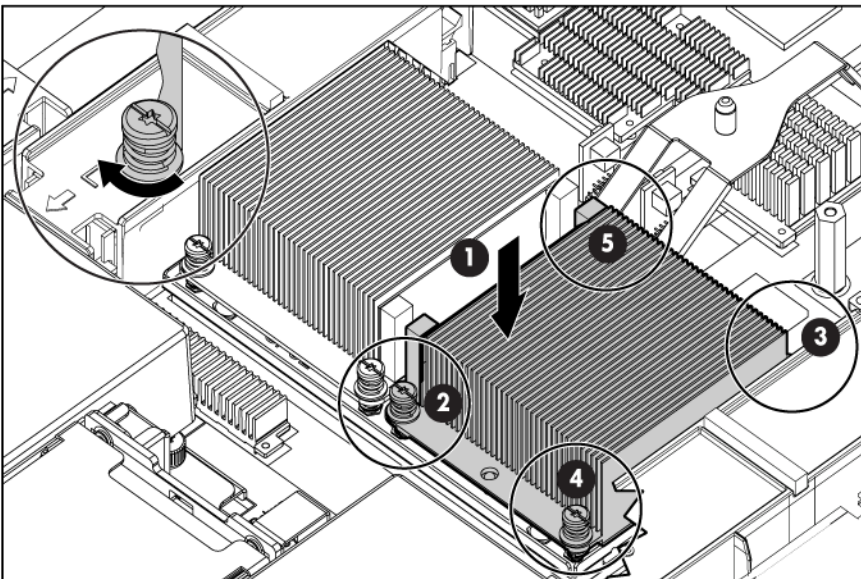

6. Install the SAS cable, if removed ("[SAS cable](#)" on page 29).
7. Install the access panel ("[Access panel](#)" on page 24).

## Processor

- 
- ⚠ **WARNING:** To reduce the risk of personal injury from hot surfaces, allow the drives and the internal system components to cool before touching them.
- 
- ⚠ **CAUTION:** To prevent possible server malfunction, do not mix processors of different speeds or cache sizes. Refer to the label on the processor heatsink for a description of the processor.
-

- △ **CAUTION:** The server blade supports only two- or four-processor configurations. Always populate processor sockets 1 and 2 with processors and heatsinks. To prevent overheating, always populate processor sockets 3 and 4 with processors and heatsinks or processor socket covers and heatsink blanks.

To remove the component:

1. Power down the server blade (on page 22).
2. Remove the server blade (on page 23).
3. Remove the access panel ("Access panel" on page 24).
4. Remove the SAS cable, if installed ("SAS cable" on page 29).
5. Remove the heatsink ("Heatsink" on page 33).
6. Open the processor retaining latch and the processor socket retaining bracket.

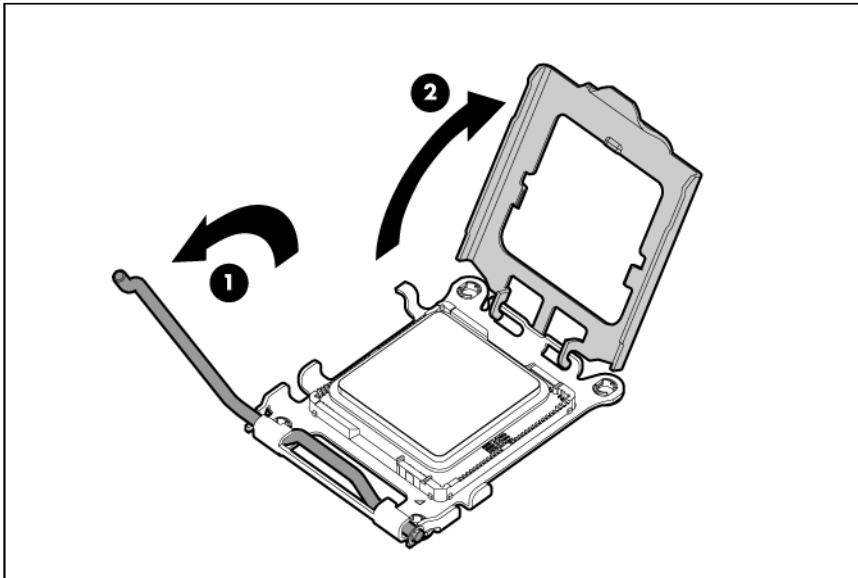

7. Using your fingers, remove the failed processor.

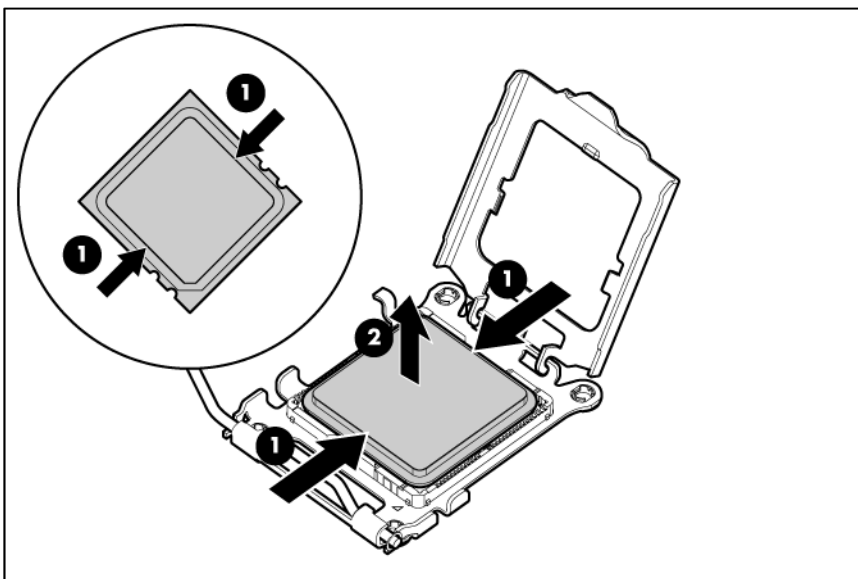

To replace the component:

△ **CAUTION:** The pins on the processor socket are very fragile. Any damage to them may require replacing the system board.

△ **CAUTION:** Failure to completely open the processor locking lever prevents the processor from seating during installation, leading to hardware damage.

📝 **IMPORTANT:** Be sure the processor remains inside the processor installation tool.

1. If the processor has separated from the installation tool, carefully re-insert the processor in the tool.

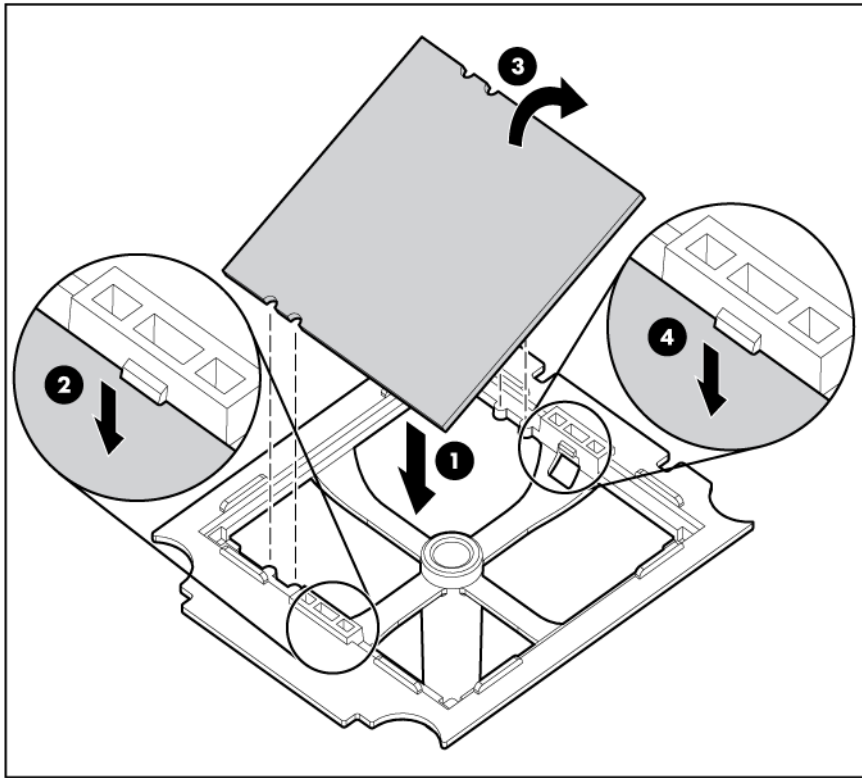

2. Align the processor installation tool with the socket and install the processor.

△ **CAUTION:** The processor is designed to fit one way into the socket. Use the alignment guides on the processor and socket to properly align the processor with the socket.

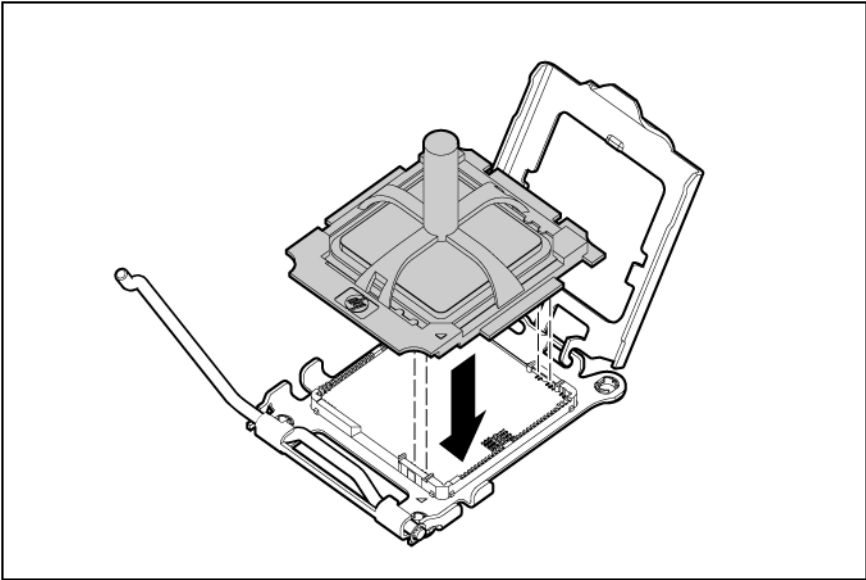

3. Press down firmly until the processor installation tool clicks and separates from the processor, and then remove the processor installation tool.

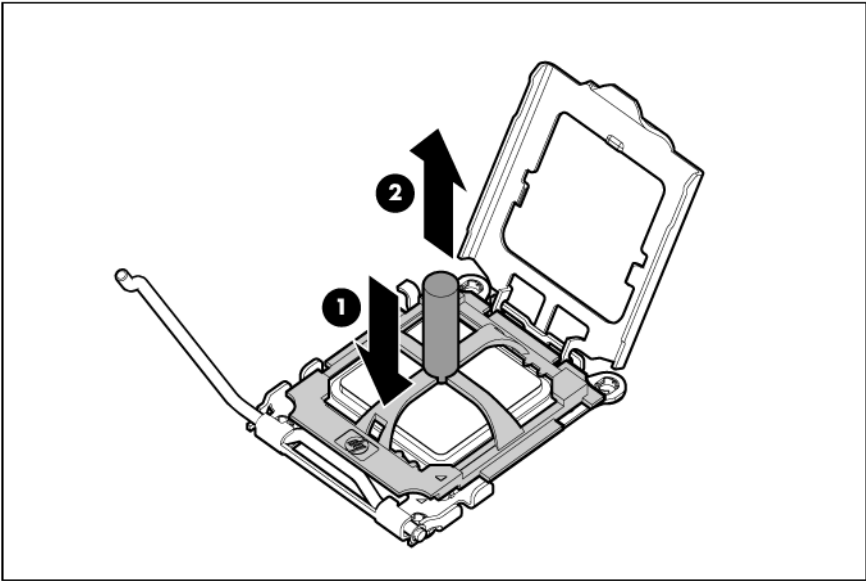



4. Close the processor retaining bracket and the processor retaining latch.

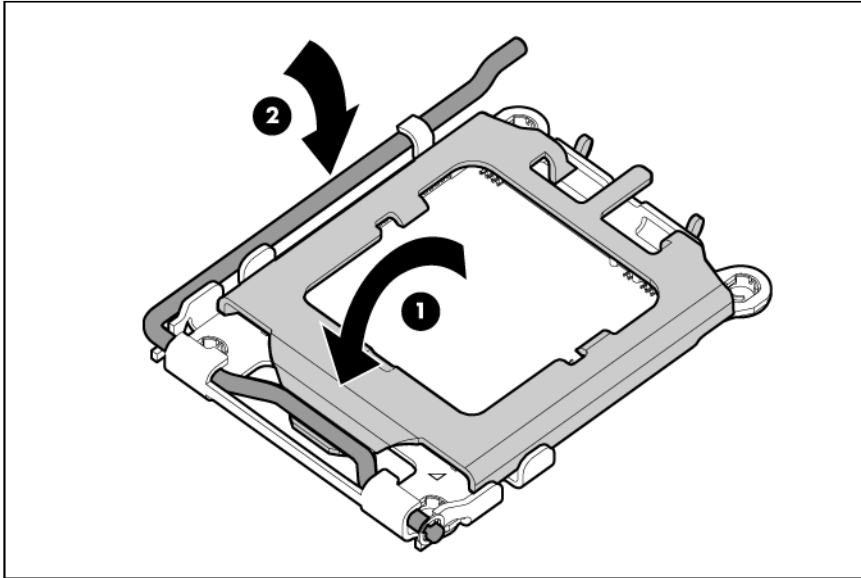

5. Clean the old thermal grease from the heatsink with the alcohol swab. Allow the alcohol to evaporate before continuing.
6. Apply all the grease to the top of the processor in the following pattern to ensure even distribution.

**CAUTION:** The heatsink thermal interface media is not reusable and must be replaced if the heatsink is removed from the processor after it has been installed.

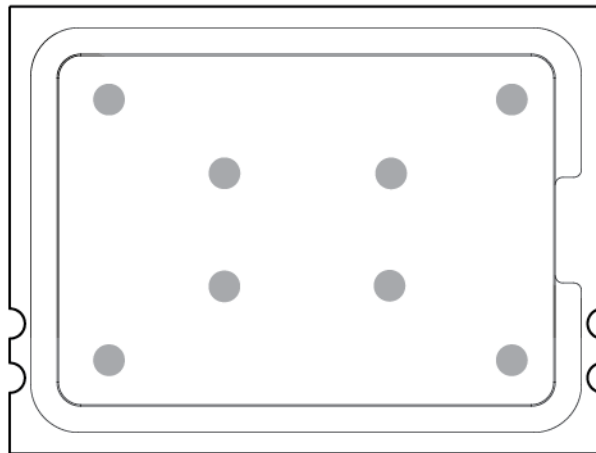

**IMPORTANT:** When replacing multiple processors, install heatsinks with attached air baffles on processors 1 and 2 only.

7. Align the heatsink:

- Processor 3 or 4

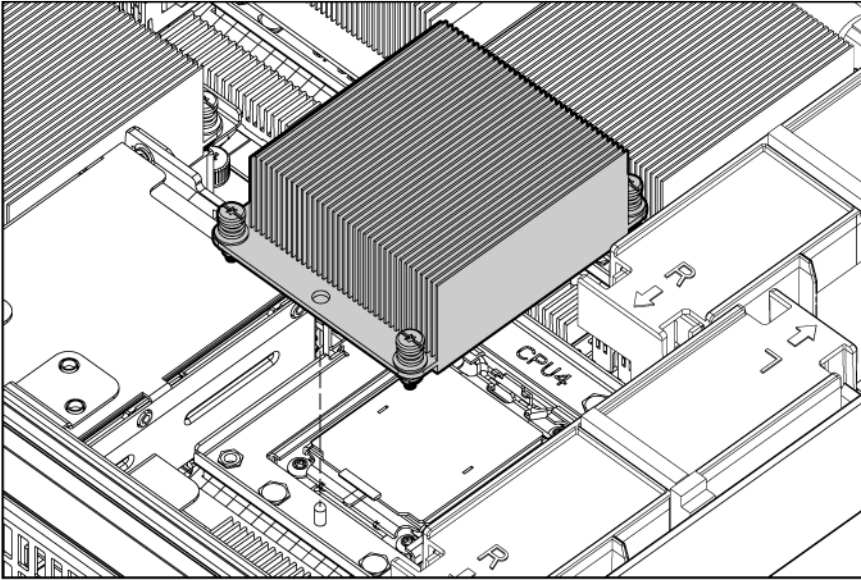

- Processor 1 or 2

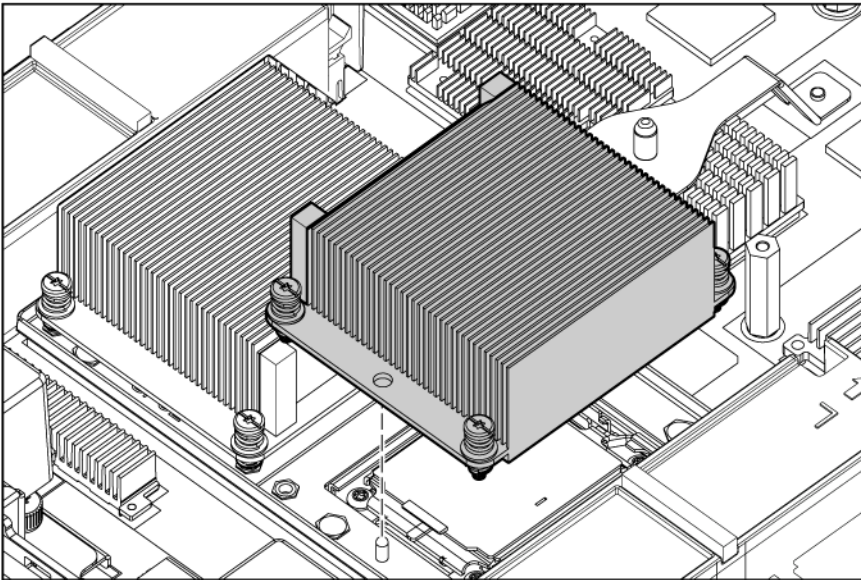

△ **CAUTION:** Heatsink retaining screws should be tightened in diagonally opposite pairs (in an "X" pattern).

8. Install the heatsink:

- Processor 3 or 4

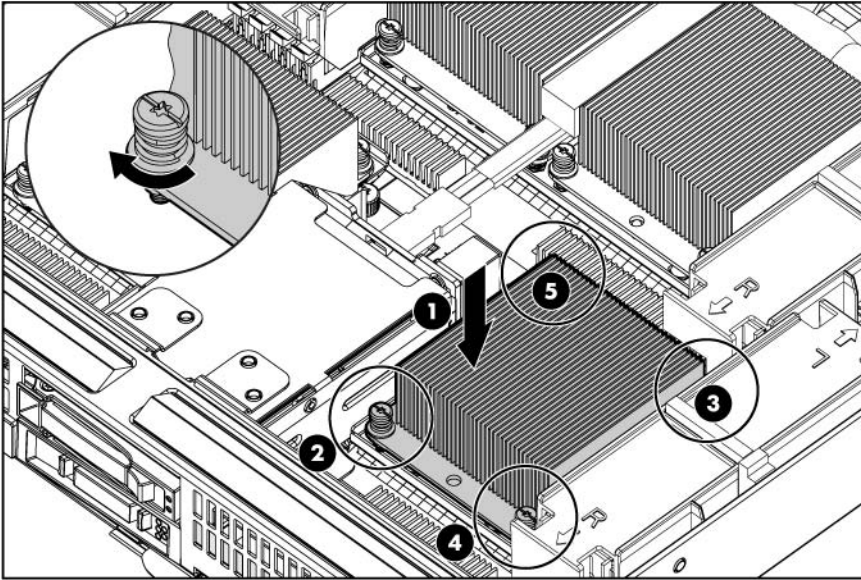

- Processor 1 or 2

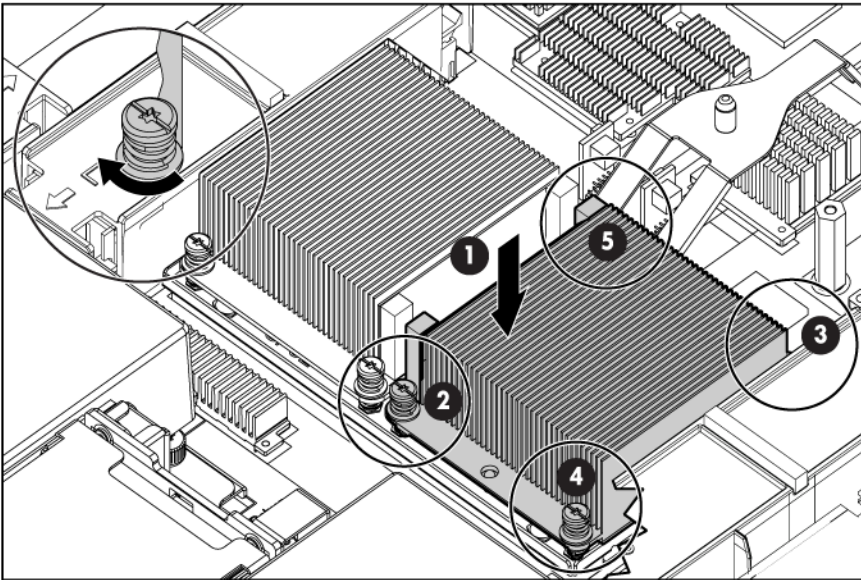

9. Install the SAS cable, if removed ("[SAS cable](#)" on page 29).
10. Install the access panel ("[Access panel](#)" on page 24).
11. Install the server blade.

## System battery

If the server blade no longer automatically displays the correct date and time, you may need to replace the battery that provides power to the real-time clock. Under normal use, battery life is 5 to 10 years.



**WARNING:** The computer contains an internal lithium manganese dioxide, a vanadium pentoxide, or an alkaline battery pack. A risk of fire and burns exists if the battery pack is not properly handled. To reduce the risk of personal injury:

- Do not attempt to recharge the battery.
- Do not expose the battery to temperatures higher than 60°C (140°F).
- Do not disassemble, crush, puncture, short external contacts, or dispose of in fire or water.
- Replace only with the spare designated for this product.

To remove the component:

1. Power down the server blade (on page 22).
2. Remove the server blade (on page 23).
3. Remove the access panel ("Access panel" on page 24).
4. Identify the battery location ("System board components" on page 59).
5. Remove the battery.

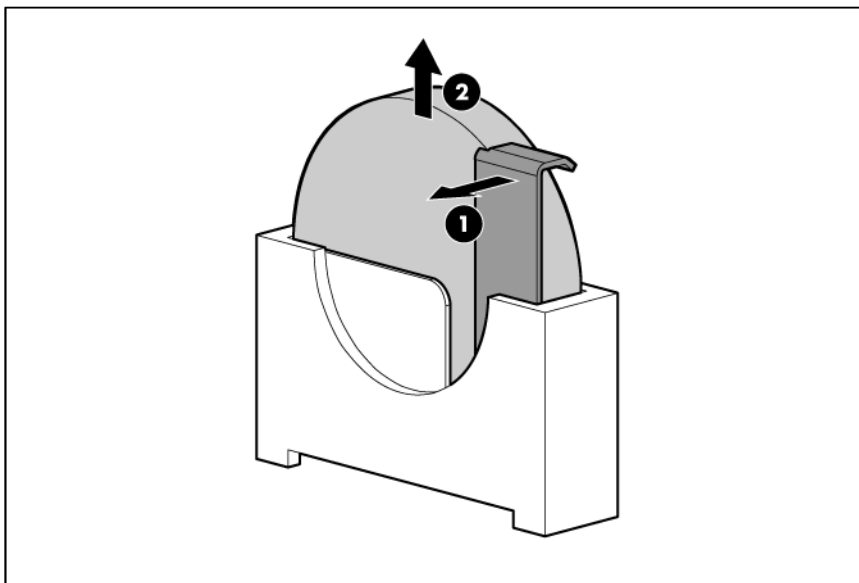

**IMPORTANT:** Replacing the system board battery resets the system ROM to its default configuration. After replacing the battery, reconfigure the system through RBSU.

To replace the component, reverse the removal procedure.

## System board

To remove the component:

1. Power down the server blade (on page 22).
2. Remove the server blade (on page 23).
3. Remove the access panel ("Access panel" on page 24).
4. Remove all hard drive blanks ("Hard drive blank" on page 25).
5. Remove all hard drives ("Hard drive" on page 25).
6. Remove the SAS cable ("SAS cable" on page 29).

7. Remove the hard drive backplane ("[Hard drive backplane](#)" on page 30).
8. Remove the front panel/hard drive cage assembly ("[Front panel/hard drive cage assembly](#)" on page 31).
9. Remove all DIMM baffles ("[DIMM baffle](#)" on page 26).
10. Remove the cache module ("[HP Smart Array E200i Controller cache module](#)" on page 28).
11. Remove all DIMMs ("[DIMMs](#)" on page 26).
12. Remove any installed mezzanine cards ("[Mezzanine card](#)" on page 27).
13. Remove the heatsink ("[Heatsink](#)" on page 33).
14. Open the processor retaining latch and the processor socket retaining bracket.

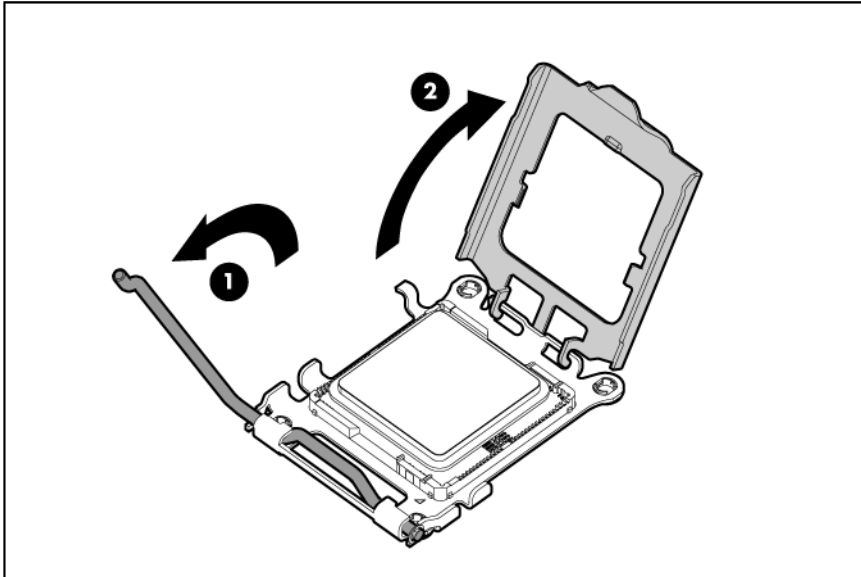

15. Using your fingers, remove the processor from the failed system board.

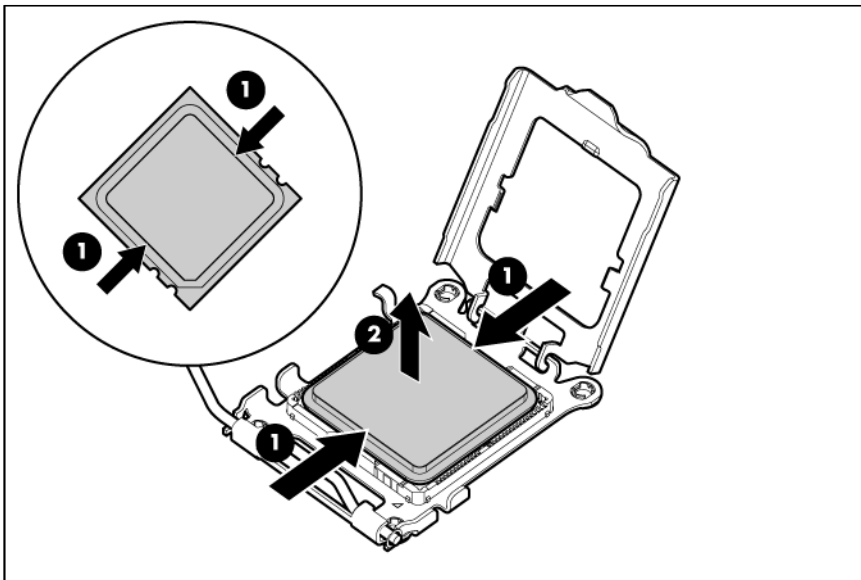



- 
- △ **CAUTION:** To avoid damage to the system board:
- Do not touch the processor socket contacts.
  - Always install the processor socket cover after removing the processor from the socket.
  - Do not tilt or slide the processor when lowering the processor into the socket.
- 
- △ **CAUTION:** To avoid damage to the processor:
- Handle the processor only by the edges.
  - Do not touch the bottom of the processor, especially the contact area.
- 

16. Remove the failed system board.

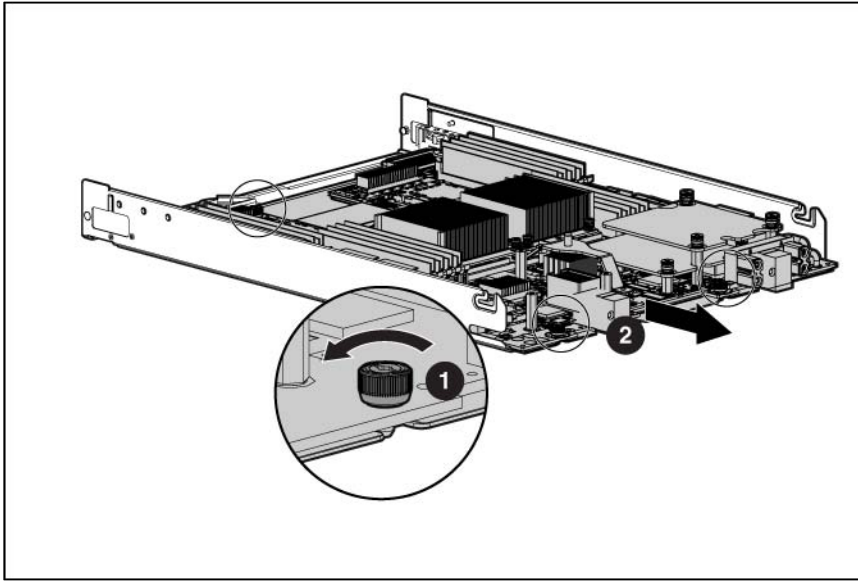

To replace the system board:

1. Install the spare system board.

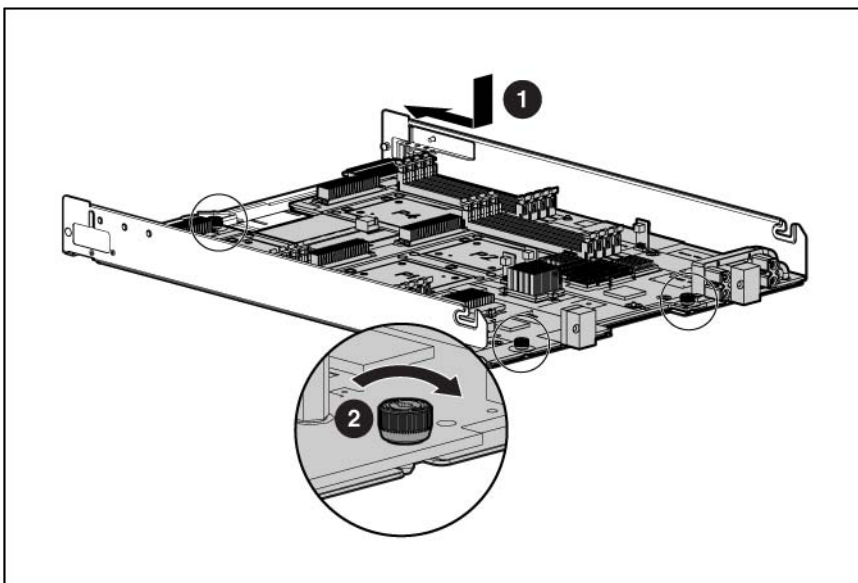

2. Prepare the processor socket on the spare system board:

- a. Remove the processor socket protective cover.

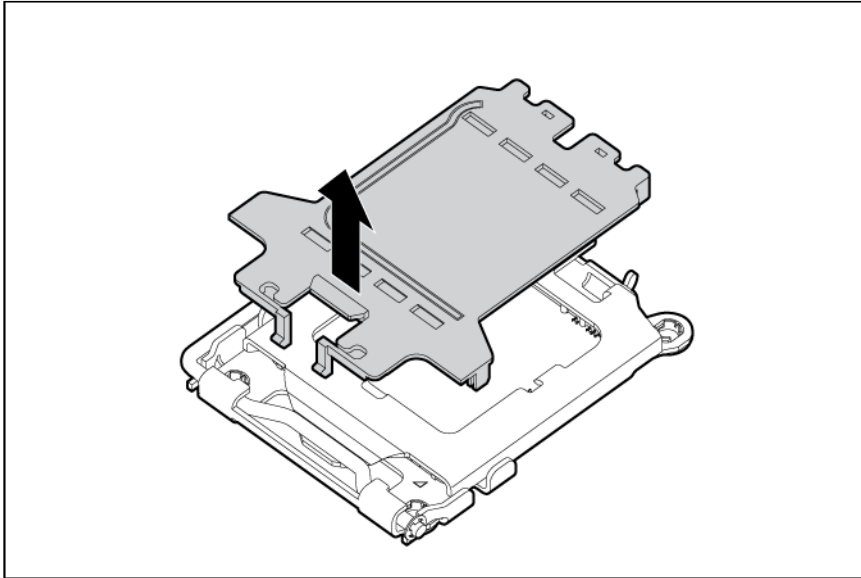

- b. Open the processor retaining latch and the processor socket retaining bracket.

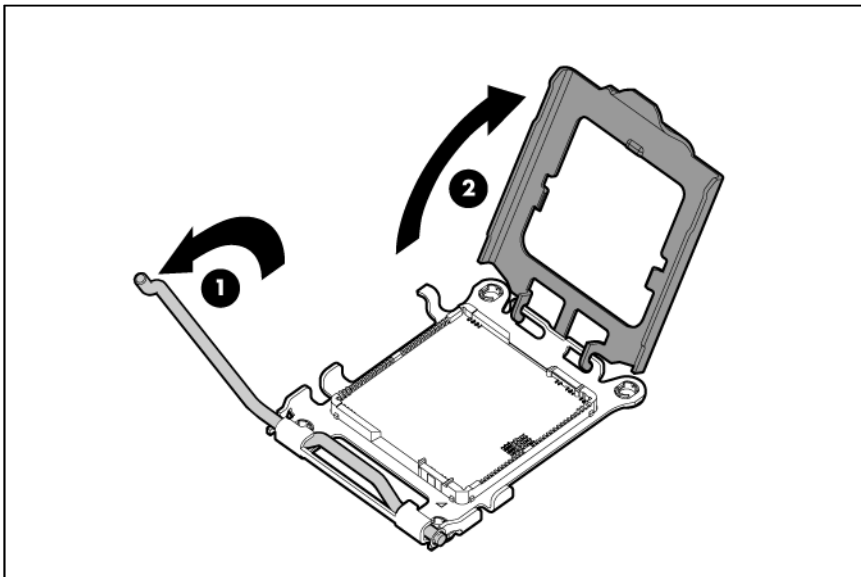

3. Install the processor socket cover onto the processor socket of the failed system board.
4. Install the processor on the spare system board.

---

△ **CAUTION:** The processor is designed to fit one way into the socket. Use the alignment guides on the processor and socket to properly align the processor with the socket. Refer to the server blade hood label for specific instructions.

---

△ **CAUTION:** Always install the processor parallel to the system board to avoid damage to the pins.

---

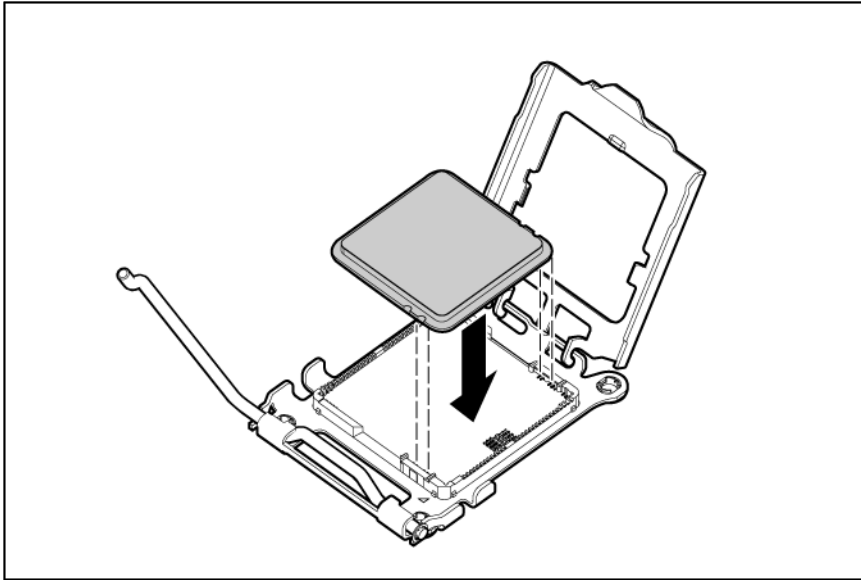

5. Close the processor retaining latch and the processor socket retaining bracket.

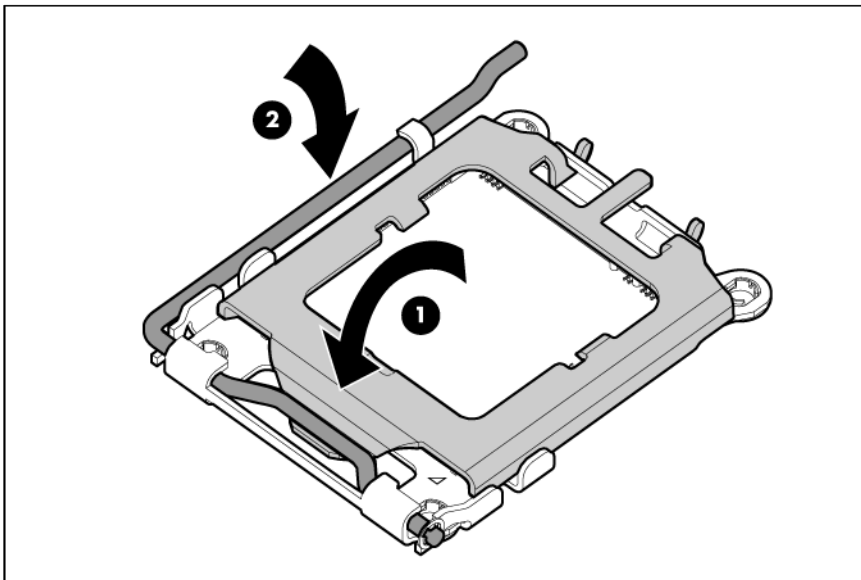

6. Clean the old thermal grease from the heatsink and the top of the processor with the alcohol swab. Allow the alcohol to evaporate before continuing.
7. Apply all the grease to the top of the processor in the following pattern to ensure even distribution.



**CAUTION:** The heatsink thermal interface media is not reusable and must be replaced if the heatsink is removed from the processor after it has been installed.



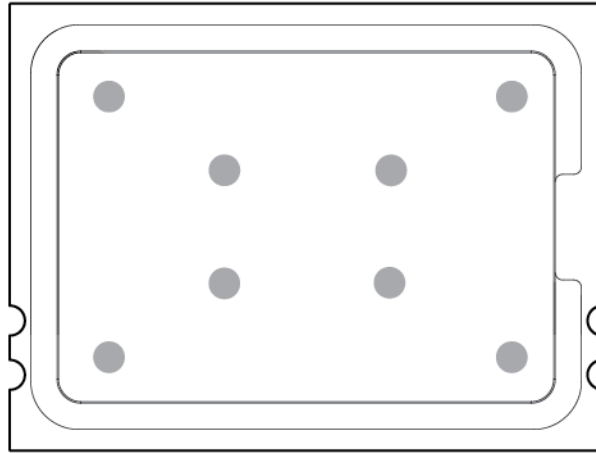

---

**IMPORTANT:** When replacing multiple processors, install heatsinks with attached air baffles on processors 1 and 2 only.

---

8. Install the heatsink.



---

**IMPORTANT:** Install all components with the same configuration that was used on the failed system board.

---

9. Install all components removed from the failed system board.
10. Install hard drives or hard drive blanks into each bay.
11. Install the access panel ("[Access panel](#)" on page 24).
12. Install the server blade.

After you replace the system board, you must re-enter the server serial number and the product ID.

1. During the server startup sequence, press the **F9** key to access RBSU.
2. Select the **System Options** menu.
3. Select **Serial Number**. The following warning is displayed:  
`WARNING! WARNING! WARNING! The serial number is loaded into the system during the manufacturing process and should NOT be modified. This option should only be used by qualified service personnel. This value should always match the serial number sticker located on the chassis.`
4. Press the **Enter** key to clear the warning.
5. Enter the serial number and press the **Enter** key.
6. Select **Product ID**.
7. Enter the product ID and press the **Enter** key.
8. Press the **Esc** key to close the menu.
9. Press the **Esc** key to exit RBSU.
10. Press the **F10** key to confirm exiting RBSU. The server will automatically reboot.

---

# Cabling

## SAS cable routing

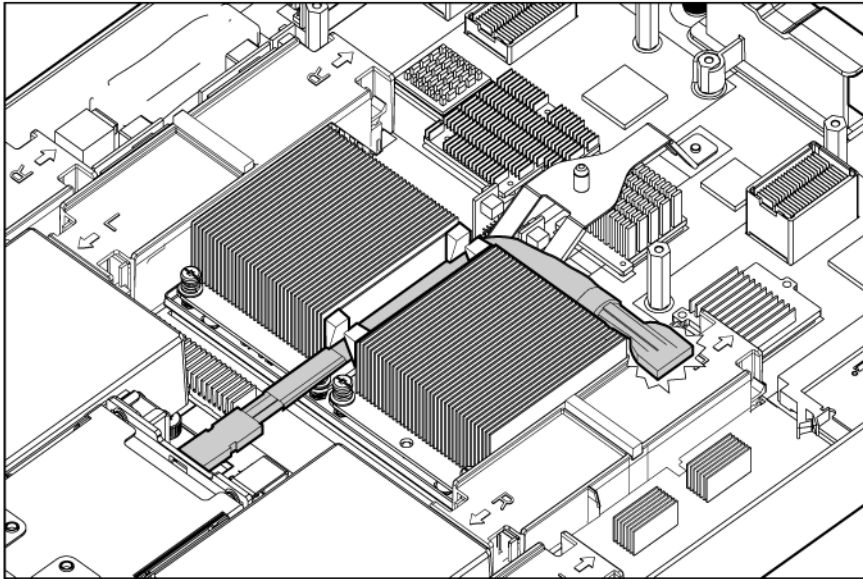

## Using the HP c-Class Blade SUV Cable

The HP c-Class Blade SUV Cable enables the user to perform server blade administration, configuration, and diagnostic procedures by connecting video and USB devices directly to the server blade. For SUV cable connectors, see "HP c-Class Blade SUV Cable (on page 62)."

## Connecting locally to a server blade with video and USB devices

Use the SUV cable to connect a monitor and any of the following USB devices:

- USB hub
- USB keyboard
- USB mouse
- USB CD/DVD-ROM drive
- USB diskette drive

Numerous configurations are possible. This section offers two possible configurations. For more information, see "USB support and functionality (on page 54)."

## Accessing a server blade with local KVM

**CAUTION:** Before disconnecting the SUV cable from the connector, always squeeze the release buttons on the sides of the connector. Failure to do so can result in damage to the equipment.

**NOTE:** For this configuration, a USB hub is not necessary. To connect additional devices, use a USB hub.

1. Connect the SUV cable to the server blade.
2. Connect the video connector to a monitor.
3. Connect a USB mouse to one USB connector.
4. Connect a USB keyboard to the second USB connector.

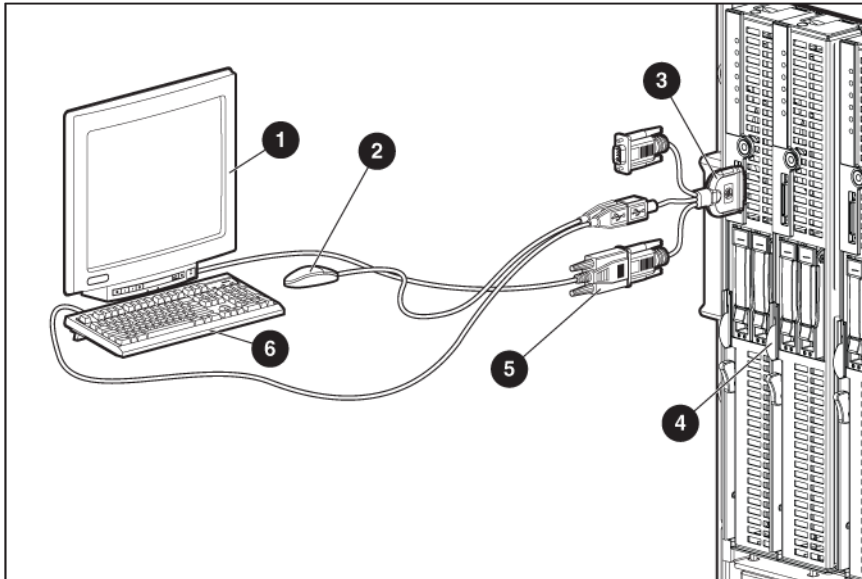

Item	Description
1	Monitor
2	USB mouse
3	HP c-Class Blade SUV cable
4	Server blade
5	Video connector
6	USB keyboard

## Accessing local media devices

Use the following configuration when configuring a server blade or loading software updates and patches from a USB CD/DVD-ROM or a USB diskette.

1. Connect the HP c-Class Blade SUV cable to the server blade.
2. Connect the video connector to a monitor.
3. Connect a USB hub to one USB connector.
4. Connect the following to the USB hub:
  - o USB CD/DVD-ROM drive
  - o USB keyboard
  - o USB mouse

- USB diskette drive

**NOTE:** Use a USB hub when connecting a USB diskette drive and/or USB CD-ROM drive to the server blade. The USB hub provides additional connections.

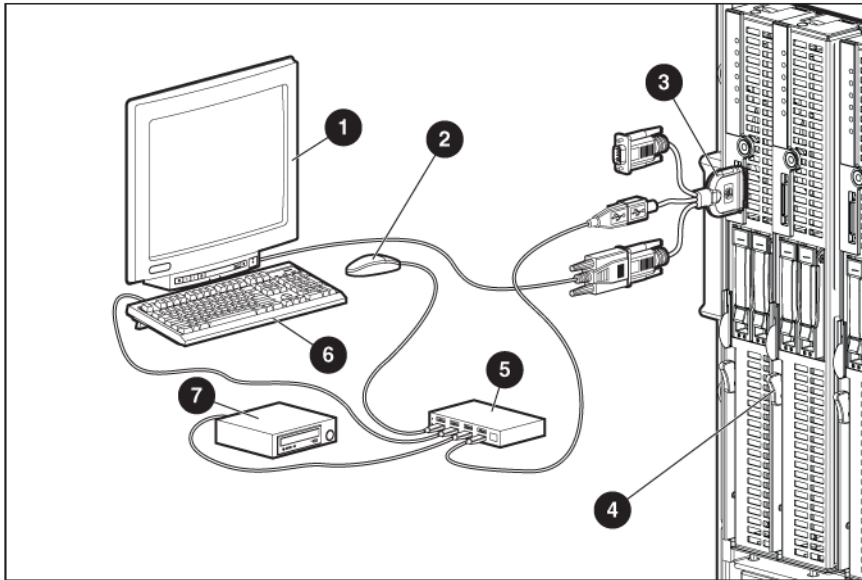

Item	Description
1	Monitor
2	USB mouse
3	HP c-Class Blade SUV cable
4	Server blade
5	USB hub
6	USB keyboard
7	USB CD/DVD-ROM drive or diskette drive

---

# Diagnostic tools

## Troubleshooting resources

The *HP ProLiant Servers Troubleshooting Guide* provides procedures for resolving common problems and comprehensive courses of action for fault isolation and identification, error message interpretation, issue resolution, and software maintenance on ProLiant servers and server blades. This guide includes problem-specific flowcharts to help you navigate complex troubleshooting processes. To view the guide, select a language:

- English ([http://www.hp.com/support/ProLiant\\_TSG\\_en](http://www.hp.com/support/ProLiant_TSG_en))
- French ([http://www.hp.com/support/ProLiant\\_TSG\\_fr](http://www.hp.com/support/ProLiant_TSG_fr))
- Italian ([http://www.hp.com/support/ProLiant\\_TSG\\_it](http://www.hp.com/support/ProLiant_TSG_it))
- Spanish ([http://www.hp.com/support/ProLiant\\_TSG\\_sp](http://www.hp.com/support/ProLiant_TSG_sp))
- German ([http://www.hp.com/support/ProLiant\\_TSG\\_gr](http://www.hp.com/support/ProLiant_TSG_gr))
- Dutch ([http://www.hp.com/support/ProLiant\\_TSG\\_nl](http://www.hp.com/support/ProLiant_TSG_nl))
- Japanese ([http://www.hp.com/support/ProLiant\\_TSG\\_jp](http://www.hp.com/support/ProLiant_TSG_jp))

The *HP BladeSystem c-Class Enclosure Troubleshooting Guide* provides procedures and solutions for troubleshooting HP BladeSystem c-Class enclosures. This guide explains how to use the Insight Display to troubleshoot enclosures, and it includes a flowchart to help you navigate the troubleshooting process. To view the guide, see the HP website ([http://www.hp.com/support/BladeSystem\\_Enclosure\\_TSG\\_en](http://www.hp.com/support/BladeSystem_Enclosure_TSG_en)).

## HP Insight Diagnostics

HP Insight Diagnostics is a proactive server blade management tool, available in both offline and online versions, that provides diagnostics and troubleshooting capabilities to assist IT administrators who verify server blade installations, troubleshoot problems, and perform repair validation.

HP Insight Diagnostics Offline Edition performs various in-depth system and component testing while the OS is not running. To run this utility, launch the SmartStart CD.

HP Insight Diagnostics Online Edition is a web-based application that captures system configuration and other related data needed for effective server blade management. Available in Microsoft® Windows® and Linux versions, the utility helps to ensure proper system operation.

For more information or to download the utility, refer to the HP website (<http://www.hp.com/servers/diags>).

## Integrated Management Log

The IML records hundreds of events and stores them in an easy-to-view form. The IML timestamps each event with 1-minute granularity.

You can view recorded events in the IML in several ways, including the following:

- From within HP SIM

- From within Survey Utility
- From within operating system-specific IML viewers
  - For NetWare: IML Viewer (does not apply to HP ProLiant DL980 Servers)
  - For Windows®: IML Viewer
  - For Linux: IML Viewer Application
- From within the iLO 2 user interface
- From within HP Insight Diagnostics (on page 53)

For more information, see the Management CD or DVD in the HP Insight Foundation suite for ProLiant.

## Array Diagnostic Utility

The HP Array Diagnostics Utility is a web-based application that creates a report of all HP storage controllers and disk drives. This report provides vital information to assist in identifying faults or conditions that may require attention. ADU can be accessed from the SmartStart CD or downloaded from the HP website (<http://www.hp.com>).

## USB support and functionality

### USB support

HP provides both standard USB 2.0 support and legacy USB 2.0 support. Standard support is provided by the OS through the appropriate USB device drivers. Before the OS loads, HP provides support for USB devices through legacy USB support, which is enabled by default in the system ROM.

Legacy USB support provides USB functionality in environments where USB support is not available normally. Specifically, HP provides legacy USB functionality for the following:

- POST
- RBSU
- Diagnostics
- DOS
- Operating environments which do not provide native USB support

### Internal USB functionality

An internal USB connector is available for use with security key devices and USB drive keys. This solution provides for use of a permanent USB key installed in the internal connector, avoiding issues of clearance on the front of the rack and physical access to secure data.

### External USB functionality

HP provides external USB support to enable local connection of USB devices for server blade administration, configuration, and diagnostic procedures. For more information, see "Using the HP c-Class Blade SUV Cable (on page 50)."

For additional security, external USB functionality can be disabled through RBSU. Disabling external USB support in RBSU disables the USB connectors on the HP c-Class Blade SUV Cable.

# Component identification

## Front panel components

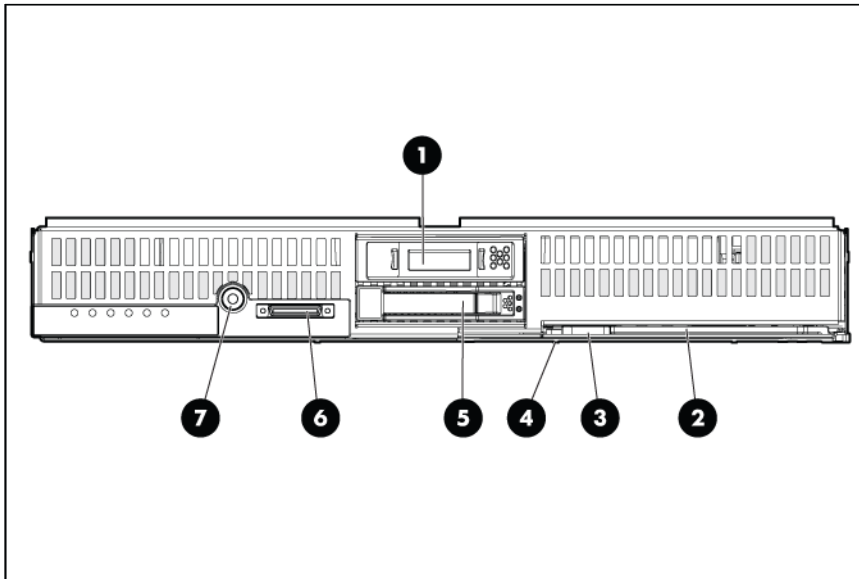

Item	Description
1	Hard drive bay 2
2	Server blade handle
3	Server blade handle release button
4	Serial pull tab
5	Hard drive bay 1
6	HP c-Class Blade SUV cable connector*
7	Power On/Standby button

\* The SUV connector and the HP c-Class Blade SUV Cable are for some server blade configuration and diagnostic procedures.



# Front panel LEDs

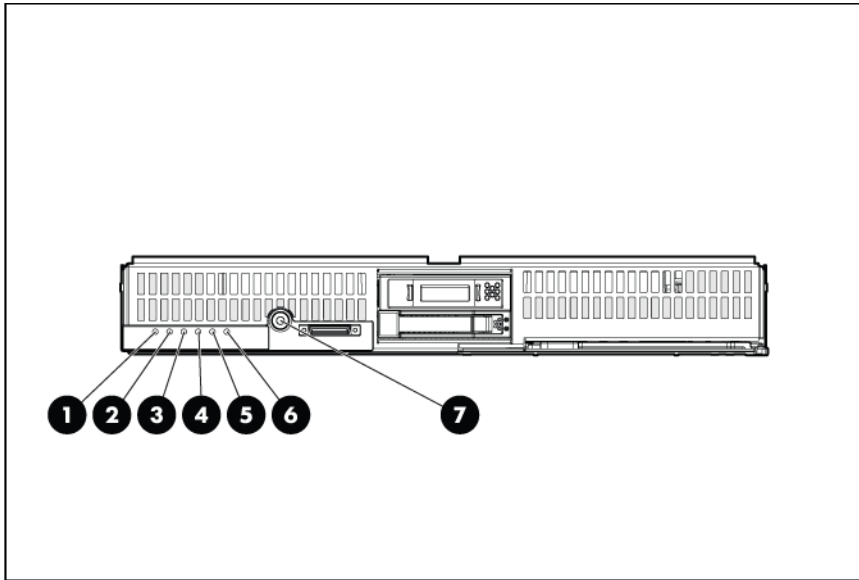

Item	Description	Status
1	UID LED	Blue = Identified Blue flashing = Active remote management Off = No active remote management
2	Health LED	Green = Normal operation Amber flashing = Degraded condition Red flashing = Critical condition
3	NIC 1 LED*	Green = Network linked Green flashing = Network activity Off = No link or activity
4	NIC 2 LED*	Green = Network linked Green flashing = Network activity Off = No link or activity
5	NIC 3 LED*	Green = Network linked Green flashing = Network activity Off = No link or activity
6	NIC 4 LED*	Green = Network linked Green flashing = Network activity Off = No link or activity
7	System power LED	Green = On Amber = Standby (auxiliary power available) Off = Off

\* Actual NIC numbers depend on several factors, including the operating system installed on the server blade.

## SAS and SATA hard drive LEDs

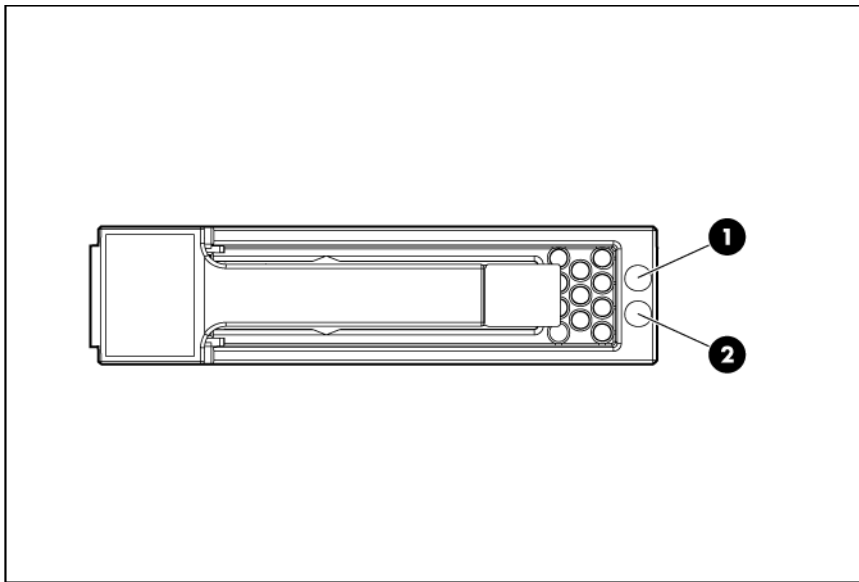

Item	Description
1	Fault/UID LED (amber/blue)
2	Online LED (green)







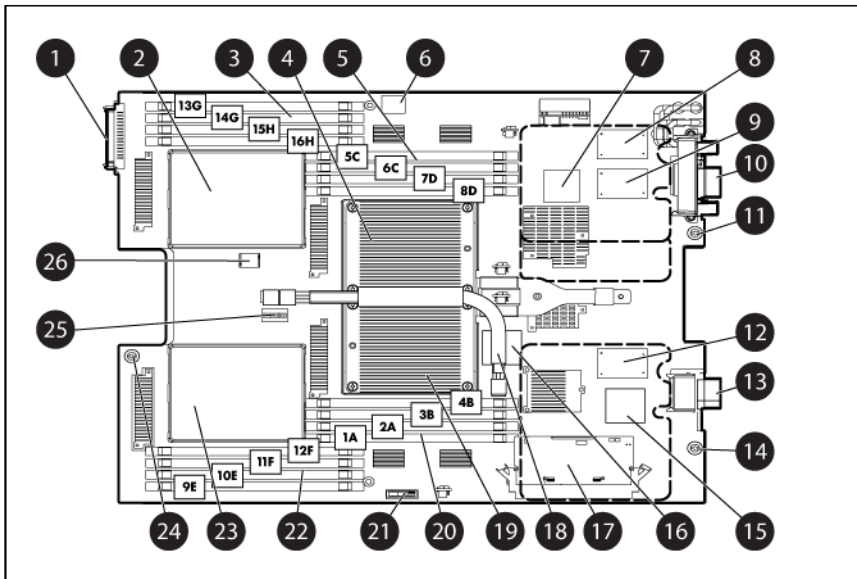

## SAS and SATA hard drive LED combinations

Online/activity LED (green)	Fault/UID LED (amber/blue)	Interpretation
On, off, or flashing	Alternating amber and blue	The drive has failed, or a predictive failure alert has been received for this drive; it also has been selected by a management application.
On, off, or flashing	Steadily blue	The drive is operating normally, and it has been selected by a management application.
On	Amber, flashing regularly (1 Hz)	A predictive failure alert has been received for this drive. Replace the drive as soon as possible.
On	Off	The drive is online, but it is not active currently.
Flashing regularly (1 Hz)	Amber, flashing regularly (1 Hz)	<b>Do not remove the drive. Removing a drive may terminate the current operation and cause data loss.</b> The drive is part of an array that is undergoing capacity expansion or stripe migration, but a predictive failure alert has been received for this drive. To minimize the risk of data loss, do not replace the drive until the expansion or migration is complete.
Flashing regularly (1 Hz)	Off	<b>Do not remove the drive. Removing a drive may terminate the current operation and cause data loss.</b> The drive is rebuilding, erasing, or it is part of an array that is undergoing capacity expansion or stripe migration.
Flashing irregularly	Amber, flashing regularly (1 Hz)	The drive is active, but a predictive failure alert has been received for this drive. Replace the drive as soon as possible.
Flashing irregularly	Off	The drive is active, and it is operating normally.





Online/activity LED (green)	Fault/UID LED (amber/blue)	Interpretation
Off	Steadily amber	A critical fault condition has been identified for this drive, and the controller has placed it offline. Replace the drive as soon as possible.
Off	Amber, flashing regularly (1 Hz)	A predictive failure alert has been received for this drive. Replace the drive as soon as possible.
Off	Off	The drive is offline, a spare, or not configured as part of an array.

## System board components



Item	Description
1	Bezel LED connector
2	Processor socket 4
3	DIMM slots (Processor 4 memory banks G and H)
4	Processor socket 2 (populated)
5	DIMM slots (Processor 2 memory banks C and D)
6	Internal USB connector
7	Embedded dual-port NIC 
8	Mezzanine connector 2 (Type I or Type II mezzanine)  
9	Mezzanine connector 1 (Type I mezzanine only) 
10	Enclosure connector 1
11	System board thumbscrew
12	Mezzanine connector 3 (Type I or Type II mezzanine)  
13	Enclosure connector 2
14	System board thumbscrew
15	Embedded NIC 
16	Embedded NIC 
17	Smart Array E200i cache module (under mezzanine card 3)

Item	Description
18	SAS cable
19	Processor socket 1 (populated)
20	DIMM slots (Processor 1 memory banks A and B)
21	System battery
22	DIMM slots (Processor 3 memory banks E and F)
23	Processor socket 3
24	System board thumbscrew
25	System maintenance switch (SW2)
26	Hard drive backplane connector

The symbols     correspond to the symbols located on the interconnect bays. For more information, see the *HP ProLiant BL685c Generation 5 Server Blade Installation Instructions* that ship with the server blade.

## Mezzanine connector definitions

PCIe x8 mezzanine connectors support x16 cards at up to x8 speeds.

Item	Connector	Card support
Mezzanine connector 1	PCIe x8	Type I mezzanine card only
Mezzanine connector 2	PCIe x8	Type I or II mezzanine card
Mezzanine connector 3	PCIe x8	Type I or II mezzanine card

## DIMM slots

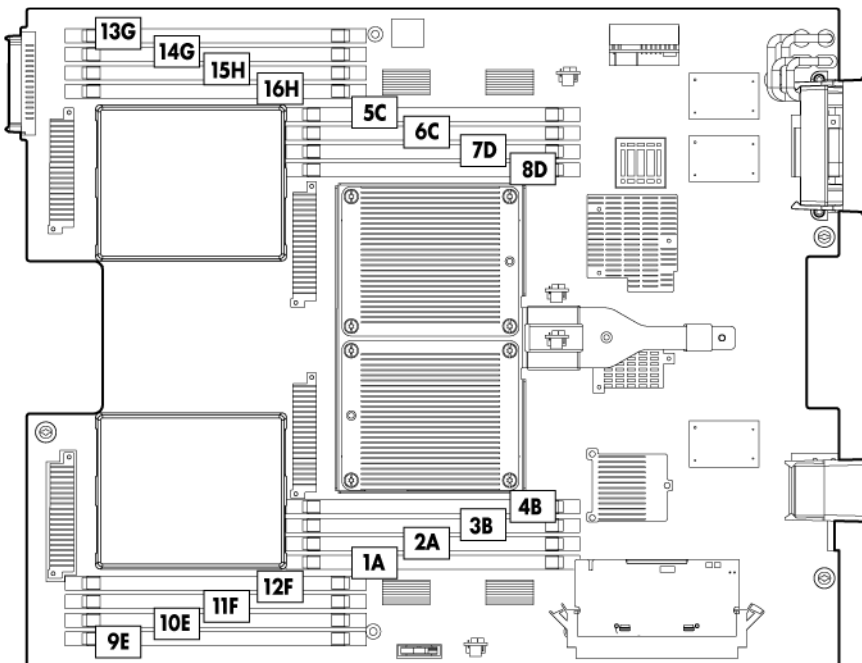

## System maintenance switch

Position	Function	Default
1*	iLO 2 security override	Off
2	Configuration lock	Off
3	Reserved	Off
4	Reserved	Off
5*	Password disabled	Off
6*	Reset configuration	Off
7	Reserved	Off
8	Reserved	Off

\*To access redundant ROM, set S1, S5, and S6 to ON.

## System maintenance switch procedures

When you perform troubleshooting steps, this guide may instruct you to perform the following procedures:

- Clear the system configuration ("[Clearing the system configuration](#)" on page 61).
- Access the redundant ROM ("[Accessing the redundant ROM](#)" on page 61).

To complete these procedures, you must change physical settings on the system maintenance switch.

### Clearing the system configuration

To clear the system configuration:

1. Power down the server blade (on page 22).
2. Remove the server blade (on page 23).
3. Remove the access panel ("[Access panel](#)" on page 24).
4. Change position 6 of the system maintenance switch to on.
5. Install the access panel ("[Access panel](#)" on page 24).
6. Install the server blade in the enclosure and power up the server blade.
7. Wait for the POST message that prompts you to change the switch setting:  
Maintenance switch detected in the "On" position.  
Power off the server and turn switch to the "Off" position.
8. Repeat steps 1 through 3.
9. Change position 6 of the system maintenance switch to off.
10. Repeat steps 5 through 7.



**IMPORTANT:** When the server blade boots after NVRAM is cleared, a delay of up to 2 minutes is normal. During this delay, the system appears non-functional. Do not attempt any procedures during the delay.

### Accessing the redundant ROM

If the system ROM is not corrupted, use RBSU to switch to the redundant ROM.

If the system ROM is corrupted, the system automatically switches to the redundant ROM in most cases. If the system does not automatically switch to the redundant ROM, perform the following steps:

1. Power down the server blade (on page 22).
2. Remove the server blade (on page 23).
3. Remove the access panel ("Access panel" on page 24).
4. Change positions 1, 5, and 6 of the system maintenance switch to on.
5. Install the access panel ("Access panel" on page 24).
6. Install the server blade in the enclosure and power up the server blade.
7. After the system beeps, repeat steps 1 through 3.
8. Change positions 1, 5, and 6 of system maintenance switch to off.
9. Repeat steps 5 and 6.

If both the current and redundant ROM are corrupted, return the system board for a service replacement.

## HP c-Class Blade SUV Cable

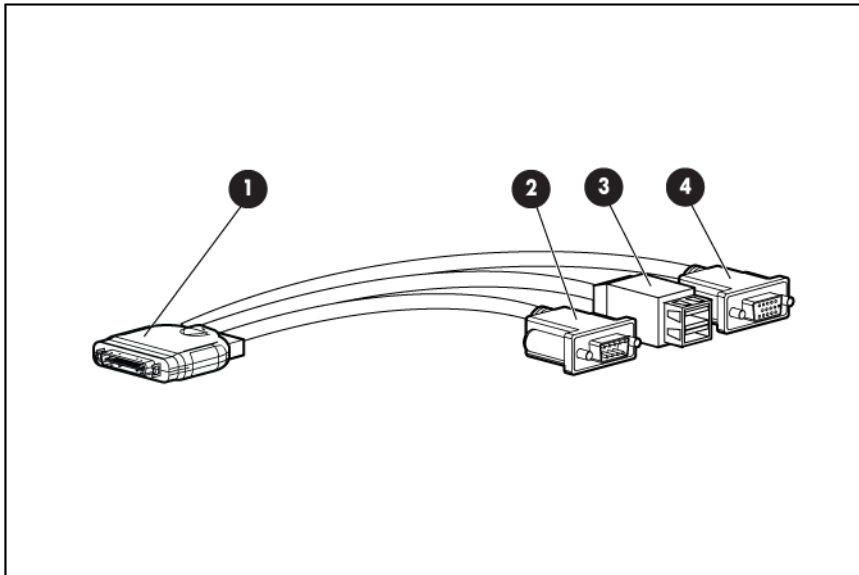

Item	Connector	Description
1	Server blade	For connecting to the SUV connector on the server blade front panel
2	Video	For connecting a video monitor
3	USB	For connecting up to two USB devices
4	Serial	For trained personnel to connect a null modem serial cable and perform advanced diagnostic procedures

# Specifications

## Environmental specifications

Specification	Value
	—
<b>Temperature range*</b>	
Operating	10°C to 35°C (50°F to 95°F)
Non-operating	-30°C to 60°C (-22°F to 140°F)
<b>Relative humidity (noncondensing)**</b>	—
Operating	10% to 90% @ 28°C (82.4°F)
Non-operating	5% to 95% @ 38.7°C (101.7°F)
<b>Altitude†</b>	—
Operating	3050 m (10,000 ft)
Non-operating	9144 m (30,000 ft)

\* The following temperature conditions and limitations apply:

- All temperature ratings shown are for sea level.
- An altitude derating of 1°C per 304.8 m (1.8°F per 1,000 ft) up to 3048 m (10,000 ft) applies.
- No direct sunlight is allowed.
- The maximum permissible rate of change is 10°C/hr (18°F/hr).
- The type and number of options installed may reduce the upper temperature and humidity limits.
- Operating with a fan fault or above 30°C (86°F) may reduce system performance.

\*\* Storage maximum humidity of 95% is based on a maximum temperature of 45°C (113°F).

† Maximum storage altitude corresponds to a minimum pressure of 70 kPa (10.1 psia).

## Server blade specifications

Specification	Value
Height	36.60 cm (14.42 in)
Depth	50.90 cm (20.06 in)
Width	5.14 cm (2.03 in)
Weight (maximum)	9.53 kg (21.02 lb)

---

# Acronyms and abbreviations

## ADU

Array Diagnostics Utility

## CSR

Customer Self Repair

## DIMM

dual inline memory module

## ESD

electrostatic discharge

## FC

Fibre Channel

## HBA

host bus adapter

## I/O

input/output

## iLO 2

Integrated Lights-Out 2

## IML

Integrated Management Log

## NIC

network interface controller

## PCIe

peripheral component interconnect express

## RBSU

ROM-Based Setup Utility



## SAS

serial attached SCSI

## SATA

serial ATA

## SFF

small form-factor

## SIM

Systems Insight Manager

## UID

unit identification

## USB

universal serial bus

---

# Index

## A

access panel 24  
ADU (Array Diagnostic Utility) 54

## B

battery 43  
battery pack, removing 29  
battery-backed write cache battery pack 29  
buttons 56

## C

cables 29, 50  
cabling 50  
cache module 28  
cautions 21  
components 16, 21, 24, 56, 59  
components, identification 56, 59  
connectors 56, 60  
CSR (customer self repair) 5

## D

diagnostic tools 53  
diagnostics utility 53  
DIMM baffles 26  
DIMM slots 60  
DIMMs 26

## E

electrostatic discharge 21

## F

features 56  
front panel components 56  
front panel LEDs 57  
front panel/hard drive cage assembly 31

## H

hard drive backplane 30  
hard drive blanks 25

hard drive LEDs 58  
hard drives 37, 58  
hard drives, determining status of 58  
hard drives, installing 25  
heatsink 33  
HP Insight Diagnostics 53

## I

Insight Diagnostics 53  
internal USB connector 60, 61

## L

LED, health 57  
LED, power button 57  
LED, power on 57  
LED, system power 57  
LED, UID 57  
LEDs 56, 58  
LEDs, front panel 57  
LEDs, hard drive 58  
LEDs, NIC 57

## M

management tools 53  
memory 26  
mezzanine connectors 60

## P

part numbers 16  
powering down 22  
preparation procedures 22  
processor 37

## R

redundant ROM 61  
release button 32  
removal and replacement procedures 21  
removing the access panel 24  
removing the server blade 23  
resources 53  
resources, troubleshooting 53

ROM redundancy 61

## **S**

safety considerations 21

safety information 21

SAS drives 25, 58

SAS hard drive LEDs 58

SAS/SATA LED combinations 58

SATA hard drive 58

SATA hard drive LEDs 58

server blade components 56

server blade handle 32

specifications 63

specifications, environmental 63

static electricity 21

symbols on equipment 22

system battery 43

system board 44

system board battery 43

system board components 59, 61

system maintenance switch 61

## **T**

tools 21, 53

troubleshooting 53

## **U**

USB connectors 62

USB support 54

utilities 53

## **V**

video connector 62

## **W**

warnings 21

warranty 5