

# HP ProLiant DL385 G7 Server Maintenance and Service Guide

## Abstract

This guide describes identification and maintenance procedures, diagnostic tools, specifications and requirements for hardware components and software. This guide is for an experienced service technician. HP assumes you are qualified in the servicing of computer equipment, trained in recognizing hazards in products, and are familiar with weight and stability precautions.



Part Number: 588707-004  
November 2011  
Edition: 4

© Copyright 2010, 2011 Hewlett-Packard Development Company, L.P.

The information contained herein is subject to change without notice. The only warranties for HP products and services are set forth in the express warranty statements accompanying such products and services. Nothing herein should be construed as constituting an additional warranty. HP shall not be liable for technical or editorial errors or omissions contained herein.

Microsoft®, Windows®, Windows NT®, and Windows Server® are U.S. registered trademarks of Microsoft Corporation.

AMD Opteron™ is a trademark of Advanced Micro Devices, Inc.

---

# Contents

Customer self repair .....	6
Parts only warranty service.....	6
Illustrated parts catalog .....	17
Mechanical components .....	17
System components .....	20
Removal and replacement procedures .....	26
Required tools.....	26
Safety considerations.....	26
Preventing electrostatic discharge .....	26
Server warnings and cautions.....	26
Preparation procedures.....	27
Power down the server .....	27
Extend the server from the rack.....	28
Remove the server from the rack .....	28
Access the product rear panel .....	29
SAS hard drive blank .....	30
Hot-plug SAS hard drive .....	31
Power supply blank .....	31
Hot-plug power supply.....	32
Front right bezel.....	33
Access panel .....	34
Optical drive .....	34
Optical drive cage .....	35
Hot-plug fan.....	36
Power supply backplane .....	38
SFF hard drive backplane .....	39
SFF hard drive cage .....	40
LFF hard drive backplane.....	41
LFF hard drive cage.....	42
Full-length expansion board shipping bracket.....	43
PCI riser cage .....	44
Expansion slot covers .....	45
Expansion boards .....	47
Half-length expansion board .....	47
Full-length expansion board.....	48
Air baffle.....	49
Battery-backed write cache procedures.....	49
Removing the cache module.....	50
Removing the battery pack.....	50
Recovering data from the battery-backed write cache .....	51
Flash-backed write cache procedures .....	52
Flash-backed write cache module.....	52
Flash-backed write cache capacitor pack.....	53
Fan cage.....	54
Heatsink.....	55

Processor.....	57
Memory configurations .....	62
Advanced ECC memory.....	62
Population order .....	62
Population rules .....	63
Population guidelines.....	63
Memory bus speed.....	64
DIMMs.....	65
Battery replacement.....	65
Systems Insight Display .....	66
Front left bezel .....	67
Power supply cage assembly.....	68
System board .....	69
HP Trusted Platform Module.....	76
<b>Cabling .....</b>	<b>77</b>
SAS hard drive cabling.....	77
BBWC battery cabling.....	78
FBWC capacitor pack cabling.....	78
<b>Diagnostic tools .....</b>	<b>79</b>
Troubleshooting resources .....	79
HP Insight Diagnostics .....	79
HP Insight Diagnostics survey functionality .....	79
Integrated Management Log.....	80
HP Insight Remote Support software .....	80
USB support .....	81
<b>Component identification.....</b>	<b>82</b>
Front panel components .....	82
Front panel LEDs and buttons.....	82
Rear panel components .....	83
Rear panel LEDs and buttons .....	84
System board components .....	85
System board switches.....	86
NMI functionality .....	86
DIMM slots .....	87
Systems Insight Display LEDs .....	88
Systems Insight Display LEDs and health LED combinations .....	88
Hard drive numbering .....	89
SAS and SATA hard drive LEDs .....	90
SAS and SATA hard drive LED combinations .....	90
PCI riser cage LEDs .....	91
Non-hot-plug PCI riser board slot definitions.....	92
Battery pack LEDs.....	93
FBWC module LEDs.....	94
Hot-plug fans .....	95
<b>Specifications.....</b>	<b>96</b>
Environmental specifications.....	96
Server specifications.....	96
Power supply specifications.....	97
Hot-plug power supply calculations .....	99
CD-ROM drive specifications.....	99
DVD-ROM drive specifications.....	100

SAS and SATA hard drive specifications .....	100
Acronyms and abbreviations.....	102
Index.....	104

---

# Customer self repair

HP products are designed with many Customer Self Repair (CSR) parts to minimize repair time and allow for greater flexibility in performing defective parts replacement. If during the diagnosis period HP (or HP service providers or service partners) identifies that the repair can be accomplished by the use of a CSR part, HP will ship that part directly to you for replacement. There are two categories of CSR parts:

- **Mandatory**—Parts for which customer self repair is mandatory. If you request HP to replace these parts, you will be charged for the travel and labor costs of this service.
- **Optional**—Parts for which customer self repair is optional. These parts are also designed for customer self repair. If, however, you require that HP replace them for you, there may or may not be additional charges, depending on the type of warranty service designated for your product.

**NOTE:** Some HP parts are not designed for customer self repair. In order to satisfy the customer warranty, HP requires that an authorized service provider replace the part. These parts are identified as "No" in the Illustrated Parts Catalog.

Based on availability and where geography permits, CSR parts will be shipped for next business day delivery. Same day or four-hour delivery may be offered at an additional charge where geography permits. If assistance is required, you can call the HP Technical Support Center and a technician will help you over the telephone. HP specifies in the materials shipped with a replacement CSR part whether a defective part must be returned to HP. In cases where it is required to return the defective part to HP, you must ship the defective part back to HP within a defined period of time, normally five (5) business days. The defective part must be returned with the associated documentation in the provided shipping material. Failure to return the defective part may result in HP billing you for the replacement. With a customer self repair, HP will pay all shipping and part return costs and determine the courier/carrier to be used.

For more information about HP's Customer Self Repair program, contact your local service provider. For the North American program, refer to the HP website (<http://www.hp.com/go/selfrepair>).

## Parts only warranty service

Your HP Limited Warranty may include a parts only warranty service. Under the terms of parts only warranty service, HP will provide replacement parts free of charge.

For parts only warranty service, CSR part replacement is mandatory. If you request HP to replace these parts, you will be charged for the travel and labor costs of this service.

## Réparation par le client (CSR)

Les produits HP comportent de nombreuses pièces CSR (Customer Self Repair = réparation par le client) afin de minimiser les délais de réparation et faciliter le remplacement des pièces défectueuses. Si pendant la période de diagnostic, HP (ou ses partenaires ou mainteneurs agréés) détermine que la réparation peut être effectuée à l'aide d'une pièce CSR, HP vous l'envoie directement. Il existe deux catégories de pièces CSR:

Obligatoire - Pièces pour lesquelles la réparation par le client est obligatoire. Si vous demandez à HP de remplacer ces pièces, les coûts de déplacement et main d'œuvre du service vous seront facturés.

Facultatif - Pièces pour lesquelles la réparation par le client est facultative. Ces pièces sont également conçues pour permettre au client d'effectuer lui-même la réparation. Toutefois, si vous demandez à HP de remplacer ces pièces, l'intervention peut ou non vous être facturée, selon le type de garantie applicable à votre produit.

**REMARQUE:** Certaines pièces HP ne sont pas conçues pour permettre au client d'effectuer lui-même la réparation. Pour que la garantie puisse s'appliquer, HP exige que le remplacement de la pièce soit effectué par un Mainteneur Agréé. Ces pièces sont identifiées par la mention "Non" dans le Catalogue illustré.

Les pièces CSR sont livrées le jour ouvré suivant, dans la limite des stocks disponibles et selon votre situation géographique. Si votre situation géographique le permet et que vous demandez une livraison le jour même ou dans les 4 heures, celle-ci vous sera facturée. Pour bénéficier d'une assistance téléphonique, appelez le Centre d'assistance technique HP. Dans les documents envoyés avec la pièce de rechange CSR, HP précise s'il est nécessaire de lui retourner la pièce défectueuse. Si c'est le cas, vous devez le faire dans le délai indiqué, généralement cinq (5) jours ouvrés. La pièce et sa documentation doivent être retournées dans l'emballage fourni. Si vous ne retournez pas la pièce défectueuse, HP se réserve le droit de vous facturer les coûts de remplacement. Dans le cas d'une pièce CSR, HP supporte l'ensemble des frais d'expédition et de retour, et détermine la société de courses ou le transporteur à utiliser.

Pour plus d'informations sur le programme CSR de HP, contactez votre Mainteneur Agréé local. Pour plus d'informations sur ce programme en Amérique du Nord, consultez le site Web HP (<http://www.hp.com/go/selfrepair>).

## Service de garantie "pièces seules"

Votre garantie limitée HP peut inclure un service de garantie "pièces seules". Dans ce cas, les pièces de rechange fournies par HP ne sont pas facturées.

Dans le cadre de ce service, la réparation des pièces CSR par le client est obligatoire. Si vous demandez à HP de remplacer ces pièces, les coûts de déplacement et main d'œuvre du service vous seront facturés.

## Riparazione da parte del cliente

Per abbreviare i tempi di riparazione e garantire una maggiore flessibilità nella sostituzione di parti difettose, i prodotti HP sono realizzati con numerosi componenti che possono essere riparati direttamente dal cliente (CSR, Customer Self Repair). Se in fase di diagnostica HP (o un centro di servizi o di assistenza HP) identifica il guasto come riparabile mediante un ricambio CSR, HP lo spedisirà direttamente al cliente per la sostituzione. Vi sono due categorie di parti CSR:

**Obbligatorie** – Parti che devono essere necessariamente riparate dal cliente. Se il cliente ne affida la riparazione ad HP, deve sostenere le spese di spedizione e di manodopera per il servizio.

**Opzionali** – Parti la cui riparazione da parte del cliente è facoltativa. Si tratta comunque di componenti progettati per questo scopo. Se tuttavia il cliente ne richiede la sostituzione ad HP, potrebbe dover sostenere spese aggiuntive a seconda del tipo di garanzia previsto per il prodotto.

**NOTA:** alcuni componenti HP non sono progettati per la riparazione da parte del cliente. Per rispettare la garanzia, HP richiede che queste parti siano sostituite da un centro di assistenza autorizzato. Tali parti sono identificate da un "No" nel Catalogo illustrato dei componenti.

In base alla disponibilità e alla località geografica, le parti CSR vengono spedite con consegna entro il giorno lavorativo seguente. La consegna nel giorno stesso o entro quattro ore è offerta con un supplemento di costo solo in alcune zone. In caso di necessità si può richiedere l'assistenza telefonica di un addetto del centro di supporto tecnico HP. Nel materiale fornito con una parte di ricambio CSR, HP specifica se il cliente deve restituire dei componenti. Qualora sia richiesta la resa ad HP del componente difettoso, lo si deve spedire ad HP entro un determinato periodo di tempo, generalmente cinque (5) giorni lavorativi. Il componente difettoso deve essere restituito con la documentazione associata nell'imballo di spedizione fornito. La mancata restituzione del componente può comportare la fatturazione del ricambio da parte di HP. Nel caso di riparazione da parte del cliente, HP sostiene tutte le spese di spedizione e resa e sceglie il corriere/vettore da utilizzare.

Per ulteriori informazioni sul programma CSR di HP contattare il centro di assistenza di zona. Per il programma in Nord America fare riferimento al sito Web HP (<http://www.hp.com/go/selfrepair>).

## Servizio di garanzia per i soli componenti

La garanzia limitata HP può includere un servizio di garanzia per i soli componenti. Nei termini di garanzia del servizio per i soli componenti, HP fornirà gratuitamente le parti di ricambio.

Per il servizio di garanzia per i soli componenti è obbligatoria la formula CSR che prevede la riparazione da parte del cliente. Se il cliente invece richiede la sostituzione ad HP, dovrà sostenere le spese di spedizione e di manodopera per il servizio.

## Customer Self Repair

HP Produkte enthalten viele CSR-Teile (Customer Self Repair), um Reparaturzeiten zu minimieren und höhere Flexibilität beim Austausch defekter Bauteile zu ermöglichen. Wenn HP (oder ein HP Servicepartner) bei der Diagnose feststellt, dass das Produkt mithilfe eines CSR-Teils repariert werden kann, sendet Ihnen HP dieses Bauteil zum Austausch direkt zu. CSR-Teile werden in zwei Kategorien unterteilt:

Zwingend – Teile, für die das Customer Self Repair-Verfahren zwingend vorgegeben ist. Wenn Sie den Austausch dieser Teile von HP vornehmen lassen, werden Ihnen die Anfahrt- und Arbeitskosten für diesen Service berechnet.

Optional – Teile, für die das Customer Self Repair-Verfahren optional ist. Diese Teile sind auch für Customer Self Repair ausgelegt. Wenn Sie jedoch den Austausch dieser Teile von HP vornehmen lassen möchten, können bei diesem Service je nach den für Ihr Produkt vorgesehenen Garantiebedingungen zusätzliche Kosten anfallen.

**HINWEIS:** Einige Teile sind nicht für Customer Self Repair ausgelegt. Um den Garantieanspruch des Kunden zu erfüllen, muss das Teil von einem HP Servicepartner ersetzt werden. Im illustrierten Teilekatalog sind diese Teile mit „No“ bzw. „Nein“ gekennzeichnet.

CSR-Teile werden abhängig von der Verfügbarkeit und vom Lieferziel am folgenden Geschäftstag geliefert. Für bestimmte Standorte ist eine Lieferung am selben Tag oder innerhalb von vier Stunden gegen einen Aufpreis verfügbar. Wenn Sie Hilfe benötigen, können Sie das HP technische Support Center anrufen und sich von einem Mitarbeiter per Telefon helfen lassen. Den Materialien, die mit einem CSR-Ersatzteil geliefert werden, können Sie entnehmen, ob das defekte Teil an HP zurückgeschickt werden muss. Wenn es erforderlich ist, das defekte Teil an HP zurückzuschicken, müssen Sie dies innerhalb eines vorgegebenen Zeitraums tun, in der Regel innerhalb von fünf (5) Geschäftstagen. Das defekte Teil muss mit der zugehörigen Dokumentation in der Verpackung zurückgeschickt werden, die im Lieferumfang enthalten ist. Wenn Sie das



defekte Teil nicht zurückschicken, kann HP Ihnen das Ersatzteil in Rechnung stellen. Im Falle von Customer Self Repair kommt HP für alle Kosten für die Lieferung und Rücksendung auf und bestimmt den Kurier-/Frachtdienst.

Weitere Informationen über das HP Customer Self Repair Programm erhalten Sie von Ihrem Servicepartner vor Ort. Informationen über das CSR-Programm in Nordamerika finden Sie auf der HP Website unter (<http://www.hp.com/go/selfrepair>).

## Parts-only Warranty Service (Garantieservice ausschließlich für Teile)

Ihre HP Garantie umfasst möglicherweise einen Parts-only Warranty Service (Garantieservice ausschließlich für Teile). Gemäß den Bestimmungen des Parts-only Warranty Service stellt HP Ersatzteile kostenlos zur Verfügung.

Für den Parts-only Warranty Service ist das CSR-Verfahren zwingend vorgegeben. Wenn Sie den Austausch dieser Teile von HP vornehmen lassen, werden Ihnen die Anfahrt- und Arbeitskosten für diesen Service berechnet.

## Reparaciones del propio cliente

Los productos de HP incluyen muchos componentes que el propio usuario puede reemplazar (*Customer Self Repair*, CSR) para minimizar el tiempo de reparación y ofrecer una mayor flexibilidad a la hora de realizar sustituciones de componentes defectuosos. Si, durante la fase de diagnóstico, HP (o los proveedores o socios de servicio de HP) identifica que una reparación puede llevarse a cabo mediante el uso de un componente CSR, HP le enviará dicho componente directamente para que realice su sustitución. Los componentes CSR se clasifican en dos categorías:

- **Obligatorio:** componentes para los que la reparación por parte del usuario es obligatoria. Si solicita a HP que realice la sustitución de estos componentes, tendrá que hacerse cargo de los gastos de desplazamiento y de mano de obra de dicho servicio.
- **Opcional:** componentes para los que la reparación por parte del usuario es opcional. Estos componentes también están diseñados para que puedan ser reparados por el usuario. Sin embargo, si precisa que HP realice su sustitución, puede o no conllevar costes adicionales, dependiendo del tipo de servicio de garantía correspondiente al producto.

**NOTA:** Algunos componentes no están diseñados para que puedan ser reparados por el usuario. Para que el usuario haga valer su garantía, HP pone como condición que un proveedor de servicios autorizado realice la sustitución de estos componentes. Dichos componentes se identifican con la palabra "No" en el catálogo ilustrado de componentes.

Según la disponibilidad y la situación geográfica, los componentes CSR se enviarán para que lleguen a su destino al siguiente día laborable. Si la situación geográfica lo permite, se puede solicitar la entrega en el mismo día o en cuatro horas con un coste adicional. Si precisa asistencia técnica, puede llamar al Centro de asistencia técnica de HP y recibirá ayuda telefónica por parte de un técnico. Con el envío de materiales para la sustitución de componentes CSR, HP especificará si los componentes defectuosos deberán devolverse a HP. En aquellos casos en los que sea necesario devolver algún componente a HP, deberá hacerlo en el periodo de tiempo especificado, normalmente cinco días laborables. Los componentes defectuosos deberán devolverse con toda la documentación relacionada y con el embalaje de envío. Si no

enviara el componente defectuoso requerido, HP podrá cobrarle por el de sustitución. En el caso de todas sustituciones que lleve a cabo el cliente, HP se hará cargo de todos los gastos de envío y devolución de componentes y escogerá la empresa de transporte que se utilice para dicho servicio.

Para obtener más información acerca del programa de Reparaciones del propio cliente de HP, póngase en contacto con su proveedor de servicios local. Si está interesado en el programa para Norteamérica, visite la página web de HP siguiente (<http://www.hp.com/go/selfrepair>).

## Servicio de garantía exclusivo de componentes

La garantía limitada de HP puede que incluya un servicio de garantía exclusivo de componentes. Según las condiciones de este servicio exclusivo de componentes, HP le facilitará los componentes de repuesto sin cargo adicional alguno.

Para este servicio de garantía exclusivo de componentes, es obligatoria la sustitución de componentes por parte del usuario (CSR). Si solicita a HP que realice la sustitución de estos componentes, tendrá que hacerse cargo de los gastos de desplazamiento y de mano de obra de dicho servicio.

## Customer Self Repair

Veel onderdelen in HP producten zijn door de klant zelf te repareren, waardoor de reparatieduur tot een minimum beperkt kan blijven en de flexibiliteit in het vervangen van defecte onderdelen groter is. Deze onderdelen worden CSR-onderdelen (Customer Self Repair) genoemd. Als HP (of een HP Service Partner) bij de diagnose vaststelt dat de reparatie kan worden uitgevoerd met een CSR-onderdeel, verzendt HP dat onderdeel rechtstreeks naar u, zodat u het defecte onderdeel daarmee kunt vervangen. Er zijn twee categorieën CSR-onderdelen:

**Verplicht:** Onderdelen waarvoor reparatie door de klant verplicht is. Als u HP verzoekt deze onderdelen voor u te vervangen, worden u voor deze service reiskosten en arbeidsloon in rekening gebracht.

**Optioneel:** Onderdelen waarvoor reparatie door de klant optioneel is. Ook deze onderdelen zijn ontworpen voor reparatie door de klant. Als u echter HP verzoekt deze onderdelen voor u te vervangen, kunnen daarvoor extra kosten in rekening worden gebracht, afhankelijk van het type garantieservice voor het product.

**OPMERKING:** Sommige HP onderdelen zijn niet ontwikkeld voor reparatie door de klant. In verband met de garantievoorwaarden moet het onderdeel door een geautoriseerde Service Partner worden vervangen. Deze onderdelen worden in de geïllustreerde onderdelencatalogus aangemerkt met "Nee".

Afhankelijk van de leverbaarheid en de locatie worden CSR-onderdelen verzonden voor levering op de eerstvolgende werkdag. Levering op dezelfde dag of binnen vier uur kan tegen meerkosten worden aangeboden, indien dit mogelijk is gezien de locatie. Indien assistentie gewenst is, belt u een HP Service Partner om via de telefoon technische ondersteuning te ontvangen. HP vermeldt in de documentatie bij het vervangende CSR-onderdeel of het defecte onderdeel aan HP moet worden geretourneerd. Als het defecte onderdeel aan HP moet worden teruggezonden, moet u het defecte onderdeel binnen een bepaalde periode, gewoonlijk vijf (5) werkdagen, retourneren aan HP. Het defecte onderdeel moet met de bijbehorende documentatie worden geretourneerd in het meegeleverde verpakkingsmateriaal. Als u het defecte onderdeel niet terugzendt, kan HP u voor het vervangende onderdeel kosten in rekening brengen. Bij reparatie door de klant betaalt HP alle verzendkosten voor het vervangende en geretourneerde onderdeel en kiest HP zelf welke koerier/transportonderneming hiervoor wordt gebruikt.

Neem contact op met een Service Partner voor meer informatie over het Customer Self Repair programma van HP. Informatie over Service Partners vindt u op de HP website (<http://www.hp.com/go/selfrepair>).

## Garantieservice "Parts Only"

Het is mogelijk dat de HP garantie alleen de garantieservice "Parts Only" omvat. Volgens de bepalingen van de Parts Only garantieservice zal HP kosteloos vervangende onderdelen ter beschikking stellen.

Voor de Parts Only garantieservice is vervanging door CSR-onderdelen verplicht. Als u HP verzoekt deze onderdelen voor u te vervangen, worden u voor deze service reiskosten en arbeidsloon in rekening gebracht.

## Reparo feito pelo cliente

Os produtos da HP são projetados com muitas peças para reparo feito pelo cliente (CSR) de modo a minimizar o tempo de reparo e permitir maior flexibilidade na substituição de peças com defeito. Se, durante o período de diagnóstico, a HP (ou fornecedores/parceiros de serviço da HP) concluir que o reparo pode ser efetuado pelo uso de uma peça CSR, a peça de reposição será enviada diretamente ao cliente. Existem duas categorias de peças CSR:

**Obrigatória** – Peças cujo reparo feito pelo cliente é obrigatório. Se desejar que a HP substitua essas peças, serão cobradas as despesas de transporte e mão-de-obra do serviço.

**Opcional** – Peças cujo reparo feito pelo cliente é opcional. Essas peças também são projetadas para o reparo feito pelo cliente. No entanto, se desejar que a HP as substitua, pode haver ou não a cobrança de taxa adicional, dependendo do tipo de serviço de garantia destinado ao produto.

**OBSERVAÇÃO:** Algumas peças da HP não são projetadas para o reparo feito pelo cliente. A fim de cumprir a garantia do cliente, a HP exige que um técnico autorizado substitua a peça. Essas peças estão identificadas com a marca "No" (Não), no catálogo de peças ilustrado.

Conforme a disponibilidade e o local geográfico, as peças CSR serão enviadas no primeiro dia útil após o pedido. Onde as condições geográficas permitirem, a entrega no mesmo dia ou em quatro horas pode ser feita mediante uma taxa adicional. Se precisar de auxílio, entre em contato com o Centro de suporte técnico da HP para que um técnico o ajude por telefone. A HP especifica nos materiais fornecidos com a peça CSR de reposição se a peça com defeito deve ser devolvida à HP. Nos casos em que isso for necessário, é preciso enviar a peça com defeito à HP dentro do período determinado, normalmente cinco (5) dias úteis. A peça com defeito deve ser enviada com a documentação correspondente no material de transporte fornecido. Caso não o faça, a HP poderá cobrar a reposição. Para as peças de reparo feito pelo cliente, a HP paga todas as despesas de transporte e de devolução da peça e determina a transportadora/serviço postal a ser utilizado.

Para obter mais informações sobre o programa de reparo feito pelo cliente da HP, entre em contato com o fornecedor de serviços local. Para o programa norte-americano, visite o site da HP (<http://www.hp.com/go/selfrepair>).

## Serviço de garantia apenas para peças

A garantia limitada da HP pode incluir um serviço de garantia apenas para peças. Segundo os termos do serviço de garantia apenas para peças, a HP fornece as peças de reposição sem cobrar nenhuma taxa.

No caso desse serviço, a substituição de peças CSR é obrigatória. Se desejar que a HP substitua essas peças, serão cobradas as despesas de transporte e mão-de-obra do serviço.

## 顧客自己修理保証サービス

修理時間を短縮し、故障部品の交換における高い柔軟性を確保するために、HP製品には多数の顧客自己修理（CSR）部品があります。診断の際に、CSR部品を使用すれば修理ができるとHP（HPまたはHP正規保守代理店）が判断した場合、HPはその部品を直接、お客様に発送し、お客様に交換していただきます。CSR部品には以下の2通りがあります。

- 必須-顧客自己修理が必須の部品。当該部品について、もしもお客様がHPに交換作業を依頼される場合には、その修理サービスに関する交通費および人件費がお客様に請求されます。
- 任意-顧客自己修理が任意である部品。この部品も顧客自己修理用です。当該部品について、もしもお客様がHPに交換作業を依頼される場合には、お買い上げの製品に適用される保証サービス内容の範囲内においては、別途費用を負担していただくことなく保証サービスを受けることができます。

注：HP製品の一部の部品は、顧客自己修理用ではありません。製品の保証を継続するためには、HPまたはHP正規保守代理店による交換作業が必須となります。部品カタログには、当該部品が顧客自己修理除外品である旨が記載されています。

部品供給が可能な場合、地域によっては、CSR部品を翌営業日に届くように発送します。また、地域によっては、追加費用を負担いただくことにより同日または4時間以内に届くように発送することも可能な場合があります。サポートが必要なときは、HPの修理受付窓口にご連絡いただければ、技術者が電話でアドバイスします。交換用のCSR部品または同梱物には、故障部品をHPに返送する必要があるかどうかが表示されています。故障部品をHPに返送する必要がある場合は、指定期限内（通常は5営業日以内）に故障部品をHPに返送してください。故障部品を返送する場合は、届いた時の梱包箱に関連書類とともに入れてください。故障部品を返送しない場合、HPから部品費用が請求されます。顧客自己修理の際には、HPは送料および部品返送費を全額負担し、使用する宅配便会社や運送会社を指定します。

## 部品のみ保証サービス

HP保証サービスには、部品のみ保証サービスが適用される場合があります。このサービスでは、交換部品は無償で提供されます。

部品のみ保証サービスにおいては、CSR部品をお客様により交換作業していただくことが必須となります。当該部品について、もしもお客様がHPに交換作業を依頼される場合には、その修理サービスに関する交通費および人件費はお客様の負担となります。

# 客户自行维修

HP 产品提供许多客户自行维修 (CSR) 部件，以尽可能缩短维修时间和在更换缺陷部件方面提供更大的灵活性。如果在诊断期间 HP（或 HP 服务提供商或服务合作伙伴）确定可以通过使用 CSR 部件完成维修，HP 将直接把该部件发送给您进行更换。有两类 CSR 部件：

- **强制性的** — 要求客户必须自行维修的部件。如果您请求 HP 更换这些部件，则必须为该服务支付差旅费和人工费用。
- **可选的** — 客户可以选择是否自行维修的部件。这些部件也是为客户自行维修设计的。不过，如果您要求 HP 为您更换这些部件，则根据为您的产品指定的保修服务类型，HP 可能收取或不再收取任何附加费用。

**注：**某些 HP 部件的设计并未考虑客户自行维修。为了满足客户保修的需要，HP 要求授权服务提供商更换相关部件。这些部件在部件图解目录中标记为“否”。

CSR 部件将在下一个工作日发运（取决于备货情况和允许的地理范围）。在允许的地理范围内，可在当天或四小时内发运，但要收取额外费用。如果需要帮助，您可以致电 HP 技术支持中心，将会有技术人员通过电话为您提供帮助。HP 会在随更换的 CSR 部件发运的材料中指明是否必须将有缺陷的部件返还给 HP。如果要求您将有缺陷的部件返还给 HP，那么您必须在规定期限内（通常是五 (5) 个工作日）将缺陷部件发给 HP。有缺陷的部件必须随所提供的发运材料中的相关文件一起返还。如果未能送还有缺陷的部件，HP 可能会要求您支付更换费用。客户自行维修时，HP 将承担所有相关运输和部件返回费用，并指定快递商/承运商。

有关 HP 客户自行维修计划的详细信息，请与您当地的服务提供商联系。有关北美地区的计划，请访问 HP 网站 (<http://www.hp.com/go/selfrepair>)。

## 仅部件保修服务

您的 HP 有限保修服务可能涉及仅部件保修服务。根据仅部件保修服务条款的规定，HP 将免费提供更换的部件。

仅部件保修服务要求进行 CSR 部件更换。如果您请求 HP 更换这些部件，则必须为该服务支付差旅费和人工费用。

# 客戶自行維修

HP 產品設計了許多「客戶自行維修」(CSR) 的零件以減少維修時間，並且使得更換瑕疵零件時能有更大的彈性。如果在診斷期間 HP (或 HP 服務供應商或維修夥伴) 辨認出此項維修工作可以藉由使用 CSR 零件來完成，則 HP 將直接寄送該零件給您作更換。CSR 零件分為兩種類別：

- **強制的** — 客戶自行維修所使用的零件是強制性的。如果您要求 HP 更換這些零件，HP 將會向您收取此服務所需的外出費用與勞動成本。
- **選購的** — 客戶自行維修所使用的零件是選購的。這些零件也設計用於客戶自行維修之用。不過，如果您要求 HP 為您更換，則可能需要也可能不需要負擔額外的費用，端視針對此產品指定的保固服務類型而定。

**備註：**某些 HP 零件沒有消費者可自行維修的設計。為符合客戶保固，HP 需要授權的服務供應商更換零件。這些零件在圖示的零件目錄中，被標示為「否」。

基於材料取得及環境允許的情況下，CSR 零件將於下一個工作日以快遞寄送。在環境的允許下當天或四小時內送達，則可能需要額外的費用。若您需要協助，可致電「HP 技術支援中心」，會有一位技術人員透過電話來協助您。不論損壞的零件是否必須退回，HP 皆會在與 CSR 替換零件一起運送的材料中註明。若要將損壞的零件退回 HP，您必須在指定的一段時間內（通常為五 (5) 個工作天），將損壞的零件寄回 HP。損壞的零件必須與寄送資料中隨附的相關技術文件一併退還。如果無法退還損壞的零件，HP 可能要向您收取替換費用。針對客戶自行維修情形，HP 將負責所有運費及零件退還費用並指定使用何家快遞/貨運公司。

如需 HP 的「客戶自行維修」方案詳細資訊，請連絡您當地的服務供應商。至於北美方案，請參閱 HP 網站 (<http://www.hp.com/go/selfrepair>)。

## 僅限零件的保固服務

您的「HP 有限保固」可能包含僅限零件的保固服務。在僅限零件的保固服務情況下，HP 將免費提供替換零件。

針對僅限零件的保固服務，CSR 零件替換是強制性的。如果您要求 HP 更換這些零件，HP 將會向您收取此服務所需的外出費用與勞動成本。

## 고객 셀프 수리

HP 제품은 수리 시간을 최소화하고 결함이 있는 부품 교체 시 더욱 융통성을 발휘할 수 있도록 하기 위해 고객 셀프 수리(CSR) 부품을 다량 사용하여 설계되었습니다. 진단 기간 동안 HP(또는 HP 서비스 공급업체 또는 서비스 협력업체)에서 CSR 부품을 사용하여 수리가 가능하다고 판단되면 HP는 해당 부품을 바로 사용자에게 보내어 사용자가 교체할 수 있도록 합니다. CSR 부품에는 두 가지 종류가 있습니다.

- **고객 셀프 수리가 의무 사항인 필수 부품.** 사용자가 HP에 이 부품의 교체를 요청할 경우 이 서비스에 대한 출장비 및 작업비가 청구됩니다.
- **고객 셀프 수리가 선택 사항인 부품.** 이 부품들도 고객 셀프 수리가 가능하도록 설계되었습니다. 하지만 사용자가 HP에 이 부품의 교체를 요청할 경우 사용자가 구입한 제품에 해당하는 보증 서비스 유형에 따라 추가 비용 없이 교체가 가능할 수 있습니다.

**참고:** 일부 HP 부품은 고객 셀프 수리가 불가능하도록 설계되었습니다. HP는 만족스러운 고객 보증을 위해 공인 서비스 제공업체를 통해 부품을 교체하도록 하고 있습니다. 이러한 부품들은 Illustrated Parts Catalog에 "No"라고 표시되어 있습니다.

CSR 부품은 재고 상태와 지리적 조건이 허용하는 경우 다음 영업일 납품이 가능하도록 배송이 이루어집니다. 지리적 조건이 허용하는 경우 추가 비용이 청구되는 조건으로 당일 또는 4시간 배송이 가능할 수도 있습니다. 도움이 필요하시면 HP 기술 지원 센터로 전화하십시오. 전문 기술자가 전화로 도움을 줄 것입니다. HP는 결함이 발생한 부품을 HP로 반환해야 하는지 여부를 CSR 교체 부품과 함께 배송된 자료에 지정합니다. 결함이 발생한 부품을 HP로 반환해야 하는 경우에는 지정된 기간 내(통상 영업일 기준 5일)에 HP로 반환해야 합니다. 이 때 결함이 발생한 부품은 제공된 포장 재료에 넣어 관련 설명서와 함께 반환해야 합니다. 결함이 발생한 부품을 반환하지 않는 경우 HP가 교체 부품에 대해 비용을 청구할 수 있습니다. 고객 셀프 수리의 경우, HP는 모든 운송 및 부품 반환 비용을 부담하며 이용할 운송업체 및 택배 서비스를 결정합니다.

HP 고객 셀프 수리 프로그램에 대한 자세한 내용은 가까운 서비스 제공업체에 문의하십시오. 북미 지역의 프로그램에 대해서는 HP 웹 사이트(<http://www.hp.com/go/selfrepair>)를 참조하십시오.

## 부품 제공 보증 서비스

HP 제한 보증에는 부품 제공 보증 서비스가 포함될 수 있습니다. 이러한 경우 HP는 부품 제공 보증 서비스의 조건에 따라 교체 부품만을 무료로 제공합니다.

부품 제공 보증 서비스 제공 시 CSR 부품 교체는 의무 사항입니다. 사용자가 HP에 이 부품의 교체를 요청할 경우 이 서비스에 대한 출장비 및 작업비가 청구됩니다.



# Illustrated parts catalog

## Mechanical components

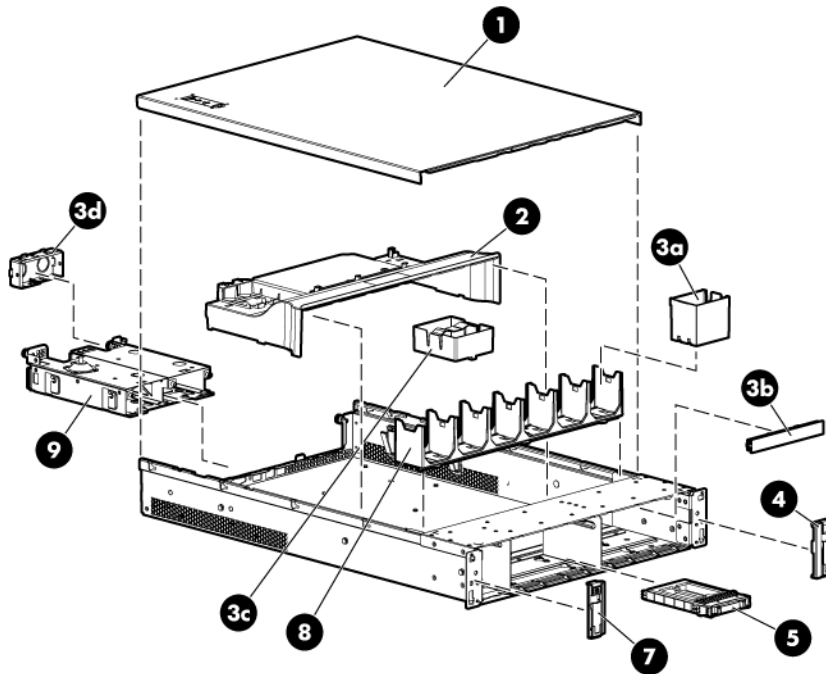

Item	Description	Assembly part number	Spare part number	Customer self repair (on page 6)
1	Access panel	463177-002	602505-001	Mandatory <sup>1</sup>
2	Air baffle	579551-001	602508-001	Mandatory <sup>1</sup>
3	Hardware kit	—	602506-001	Mandatory <sup>1</sup>
	a) Fan blank	507009-001	—	—
	b) Optical blank	505953-001	—	—
	c) Power supply blank	499244-002	602506-001	—
	d) PCI expansion slot blank, full-length*	507011-001	—	—
	e) PCI expansion slot blank, short, low-profile*	507012-001	—	—
	f) PCI retainer*	509084-001	—	—
	g) PCI retainer, top*	509085-001	—	—
	h) PCI retainer, end*	509086-001	—	—
	i) PCI retainer, removable*	509087-001	—	—
	j) T-10/T-15 Torx screwdriver holder*	373134-001	—	—
	k) Power cord retainer clip*	352993-001	—	—

Item	Description	Assembly part number	Spare part number	Customer self repair (on page 6)
	l) T-10/T-15 Torx screwdriver*	377511-001	—	—
4	Front right bezel	507415-001	602511-001	Mandatory <sup>1</sup>
5	Hard drive blank, SFF	376383-002	392613-001	Mandatory <sup>1</sup>
6	Hard drive blank, slimline interlock LFF*	336461-001	389015-001	Mandatory <sup>1</sup>
7	Front left bezel	493297-001	496080-001	Mandatory <sup>1</sup>
8	Fan cage	463180-001	496067-001	Mandatory <sup>1</sup>
9	Power supply cage assembly	463179-001	496063-001	Optional <sup>2</sup>
10	Return kit, pack box, and cushions*	—	289545-001	Mandatory <sup>1</sup>

\*Not shown

<sup>1</sup>Mandatory—Parts for which customer self repair is mandatory. If you request HP to replace these parts, you will be charged for the travel and labor costs of this service.

<sup>2</sup>Optional—Parts for which customer self repair is optional. These parts are also designed for customer self repair. If, however, you require that HP replace them for you, there may or may not be additional charges, depending on the type of warranty service designated for your product.

<sup>3</sup>No—Some HP parts are not designed for customer self repair. In order to satisfy the customer warranty, HP requires that an authorized service provider replace the part. These parts are identified as "No" in the Illustrated Parts Catalog.

<sup>1</sup>Mandatory: Obligatoire—Pièces pour lesquelles la réparation par le client est obligatoire. Si vous demandez à HP de remplacer ces pièces, les coûts de déplacement et main d'œuvre du service vous seront facturés.

<sup>2</sup>Optional: Facultatif—Pièces pour lesquelles la réparation par le client est facultative. Ces pièces sont également conçues pour permettre au client d'effectuer lui-même la réparation. Toutefois, si vous demandez à HP de remplacer ces pièces, l'intervention peut ou non vous être facturée, selon le type de garantie applicable à votre produit.

<sup>3</sup>No: Non—Certaines pièces HP ne sont pas conçues pour permettre au client d'effectuer lui-même la réparation. Pour que la garantie puisse s'appliquer, HP exige que le remplacement de la pièce soit effectué par un Mainteneur Agréé. Ces pièces sont identifiées par la mention "Non" dans le Catalogue illustré.

<sup>1</sup>Mandatory: Obbligatorie—Parti che devono essere necessariamente riparate dal cliente. Se il cliente ne affida la riparazione ad HP, deve sostenere le spese di spedizione e di manodopera per il servizio.

<sup>2</sup>Optional: Opzionali—Parti la cui riparazione da parte del cliente è facoltativa. Si tratta comunque di componenti progettati per questo scopo. Se tuttavia il cliente ne richiede la sostituzione ad HP, potrebbe dover sostenere spese addizionali a seconda del tipo di garanzia previsto per il prodotto.

<sup>3</sup>No: Non CSR—Alcuni componenti HP non sono progettati per la riparazione da parte del cliente. Per rispettare la garanzia, HP richiede che queste parti siano sostituite da un centro di assistenza autorizzato. Tali parti sono identificate da un "No" nel Catalogo illustrato dei componenti.

<sup>1</sup>Mandatory: Zwingend—Teile, die im Rahmen des Customer Self Repair Programms ersetzt werden müssen. Wenn Sie diese Teile von HP ersetzen lassen, werden Ihnen die Versand- und Arbeitskosten für diesen Service berechnet.

<sup>2</sup>Optional: Optional—Teile, für die das Customer Self Repair-Verfahren optional ist. Diese Teile sind auch für Customer Self Repair ausgelegt. Wenn Sie jedoch den Austausch dieser Teile von HP vornehmen lassen möchten, können bei diesem Service je nach den für Ihr Produkt vorgesehenen Garantiebedingungen zusätzliche Kosten anfallen.

<sup>3</sup>No: Kein—Einige Teile sind nicht für Customer Self Repair ausgelegt. Um den Garantieanspruch des Kunden zu erfüllen, muss das Teil von einem HP Servicepartner ersetzt werden. Im illustrierten Teilekatalog sind diese Teile mit „No“ bzw. „Nein“ gekennzeichnet.

<sup>1</sup>Mandatory: Obligatorio—componentes para los que la reparación por parte del usuario es obligatoria. Si solicita a HP que realice la sustitución de estos componentes, tendrá que hacerse cargo de los gastos de desplazamiento y de mano de obra de dicho servicio.

<sup>2</sup>Optional: Opcional— componentes para los que la reparación por parte del usuario es opcional. Estos componentes también están diseñados para que puedan ser reparados por el usuario. Sin embargo, si precisa que HP realice su

sustitución, puede o no conllevar costes adicionales, dependiendo del tipo de servicio de garantía correspondiente al producto.

<sup>3</sup>No: No—Algunos componentes no están diseñados para que puedan ser reparados por el usuario. Para que el usuario haga valer su garantía, HP pone como condición que un proveedor de servicios autorizado realice la sustitución de estos componentes. Dichos componentes se identifican con la palabra “No” en el catálogo ilustrado de componentes.

<sup>1</sup>Mandatory: Verplicht—Onderdelen waarvoor Customer Self Repair verplicht is. Als u HP verzoekt deze onderdelen te vervangen, komen de reiskosten en het arbeidsloon voor uw rekening.

<sup>2</sup>Optional: Optioneel—Onderdelen waarvoor reparatie door de klant optioneel is. Ook deze onderdelen zijn ontworpen voor reparatie door de klant. Als u echter HP verzoekt deze onderdelen voor u te vervangen, kunnen daarvoor extra kosten in rekening worden gebracht, afhankelijk van het type garantieservice voor het product.

<sup>3</sup>No: Nee—Sommige HP onderdelen zijn niet ontwikkeld voor reparatie door de klant. In verband met de garantiev voorwaarden moet het onderdeel door een geautoriseerde Service Partner worden vervangen. Deze onderdelen worden in de geïllustreerde onderdelencatalogus aangemerkt met "Nee".

<sup>1</sup>Mandatory: Obrigatória—Peças cujo reparo feito pelo cliente é obrigatório. Se desejar que a HP substitua essas peças, serão cobradas as despesas de transporte e mão-de-obra do serviço.

<sup>2</sup>Optional: Opcional—Peças cujo reparo feito pelo cliente é opcional. Essas peças também são projetadas para o reparo feito pelo cliente. No entanto, se desejar que a HP as substitua, pode haver ou não a cobrança de taxa adicional, dependendo do tipo de serviço de garantia destinado ao produto.

<sup>3</sup>No: Nenhuma—Algumas peças da HP não são projetadas para o reparo feito pelo cliente. A fim de cumprir a garantia do cliente, a HP exige que um técnico autorizado substitua a peça. Essas peças estão identificadas com a marca “No” (Não), no catálogo de peças ilustrado.

<sup>1</sup>Mandatory : 必須 - 顧客自己修理が必須の部品。当該部品について、もしもお客様がHPに交換作業を依頼される場合には、その修理サービスに関する交通費および人件費がお客様に請求されます。

<sup>2</sup>Optional : 任意 - 顧客自己修理が任意である部品。この部品も顧客自己修理用です。当該部品について、もしもお客様がHPに交換作業を依頼される場合には、お買い上げの製品に適用される保証サービス内容の範囲内においては、費用を負担していただくことなく保証サービスを受けることができます。

<sup>3</sup>No : 除外 - HP製品の一部の部品は、顧客自己修理用ではありません。製品の保証を継続するためには、HPまたはHP正規保守代理店による交換作業が必須となります。部品カタログには、当該部品が顧客自己修理除外品である旨が記載されています。

<sup>1</sup>Mandatory: 强制性的 — 要求客户必须自行维修的部件。如果您请求 HP 更换这些部件，则必须为该服务支付差旅费和人工费用。

<sup>2</sup>Optional: 可选的 — 客户可以选择是否自行维修的部件。这些部件也是为客户自行维修设计的。不过，如果您要求 HP 为您更换这些部件，则根据为您的产品指定的保修服务类型，HP 可能收取或不再收取任何附加费用。

<sup>3</sup>No: 否 — 某些 HP 部件的设计并未考虑客户自行维修。为了满足客户保修的需要，HP 要求授权服务提供商更换相关部件。这些部件在部件图解目录中标记为“否”。

<sup>1</sup>Mandatory: 強制的 — 客戶自行維修所使用的零件是強制的。如果您要求 HP 更換這些零件，HP 將會向您收取此服務所需的外出費用與勞動成本。

<sup>2</sup>Optional: 選購的 — 客戶自行維修所使用的零件是選購的。這些零件也設計用於客戶自行維修之用。不過，如果您要求 HP 為您更換，則可能需要也可能不需要負擔額外的費用，端視針對此產品指定的保固服務類型而定。

<sup>3</sup>No: 否 — 某些 HP 零件沒有消費者可自行維修的設計。為符合客戶保固，HP 需要授權的服務供應商更換零件。這些零件在圖示的零件目錄中，被標示為「否」。

<sup>1</sup> Mandatory: 필수 — 고객 셀프 수리가 의무 사항인 필수 부품. 사용자가 HP에 이 부품의 교체를 요청할 경우 이 서비스에 대한 출장비 및 작업비가 청구됩니다.

<sup>2</sup> Optional: 옵션 — 고객 셀프 수리가 선택 사항인 부품. 이 부품들도 고객 셀프 수리가 가능하도록 설계되었습니다. 하지만 사용자가 HP에 이 부품의 교체를 요청할 경우 사용자가 구입한 제품에 해당하는 보증 서비스 유형에 따라 추가 비용 없이 교체가 가능할 수 있습니다.

<sup>3</sup> No: No — 고객 셀프 수리가 불가능하도록 설계된 HP 부품. 이 부품들은 고객 셀프 수리가 불가능하도록 설계되었습니다. HP는 고객 보증을 만족시키기 위해 공인 서비스 제공업체를 통해 부품을 교체하도록 하고 있습니다.

# System components

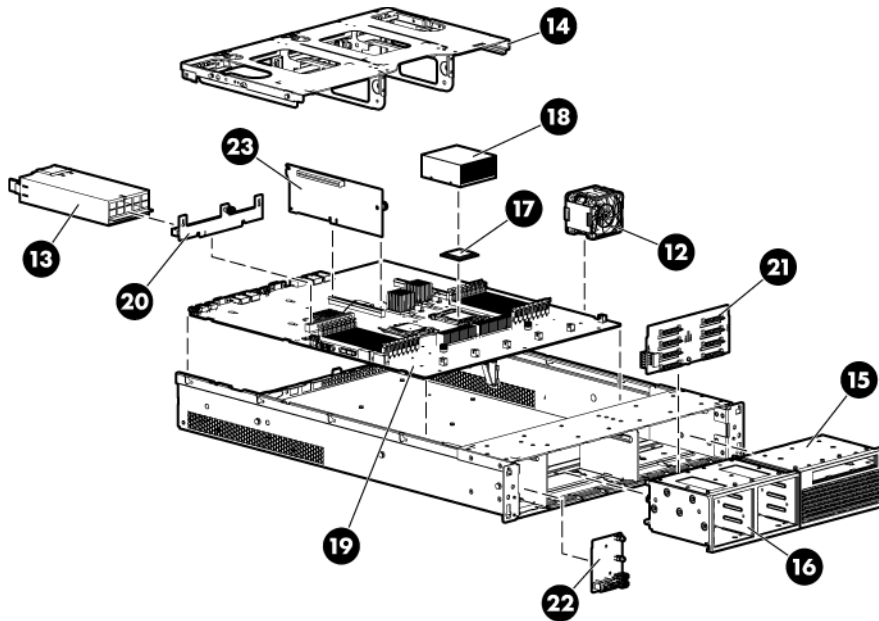

Item	Description	Assembly part number	Spare part number	Customer self repair (on page 6)
<b>System components</b>				
11	Full-length expansion board shipping bracket*	—	618597-001	Mandatory <sup>1</sup>
12	Hot-plug fan	463172-001	496066-001	Mandatory <sup>1</sup>
13	Hot-plug power supplies	—	—	—
	a) 460 W	499249-001	511777-001	Mandatory <sup>1</sup>
	b) 460 W HE 94%*	591553-001	599381-001	Mandatory <sup>1</sup>
	c) 750 W*	506821-001	511778-001	Mandatory <sup>1</sup>
	d) 750 W HE 94%*	591554-001	599383-001	Mandatory <sup>1</sup>
	e) 1200 W*	490594-001	498152-001	Mandatory <sup>1</sup>
	f) 1200 W HE 94%*	570451-101	579229-001	Mandatory <sup>1</sup>
	g) 1200 W DC*	444049-001	451816-001	Mandatory <sup>1</sup>
14	PCI riser cage with non-hot-plug PCIe riser	463170-003	614778-001	Optional <sup>2</sup>
15	Optical drive cage	463175-001	496076-001	Mandatory <sup>1</sup>
16	Hard drive cage	—	—	—
	a) SFF hard drive cage	463173-001	496074-001	Mandatory <sup>1</sup>
	b) LFF hard drive cage*	463174-001	496075-001	Mandatory <sup>1</sup>
17	Processor	—	—	—
	a) 2.0-GHz, 8C AMD Opteron™ Model 6128**	578022-003	598732-001	Optional <sup>2</sup>

Item	Description	Assembly part number	Spare part number	Customer self repair (on page 6)
	b) 2.0-GHz, 8C AMD Opteron™ Model 6128HE* **	578023-001	583751-001	Optional <sup>2</sup>
	c) 2.2-GHz 8C AMD Opteron™ Model 6132HE* **	578023-005	633546-001	Optional <sup>2</sup>
	d) 2.3-GHz, 8C AMD Opteron™ Model 6134* **	578022-002	583752-001	Optional <sup>2</sup>
	e) 2.4-GHz, AMD Opteron™ Model 6136* **	578022-001	583753-001	Optional <sup>2</sup>
	f) 2.6-GHz 8C AMD Opteron™ Model 6140* **	578022-006	633544-001	Optional <sup>2</sup>
	g) 1.8-GHz 12C AMD Opteron™ Model 6166HE* **	596136-002	633545-001	Optional <sup>2</sup>
	h) 2.1-GHz, 12C AMD Opteron™ Model 6172* **	578015-001	583755-001	Optional <sup>2</sup>
	i) 2.2-GHz 12C AMD Opteron™ Model 6174* **	578015-005	598729-001	Optional <sup>2</sup>
	j) 2.3-GHz 12C AMD Opteron™ Model 6176* **	578015-006	633722-001	Optional <sup>2</sup>
	k) 2.3-GHz 12C AMD Opteron™ Model 6176SE* **	596121-001	599220-001	Optional <sup>2</sup>
	l) 2.5-GHz 12C AMD Opteron™ Model 6180SE* **	596121-003	634956-001	Optional <sup>2</sup>
	m) 2.6-GHz 8C AMD Opteron™ Model 6212* **	655497-002	662840-001	Optional <sup>2</sup>
	n) 3.0-GHz 8C AMD Opteron™ Model 6220* **	655497-001	662839-001	Optional <sup>2</sup>
	o) 2.4-GHz 12C AMD Opteron™ Model 6234* **	654523-002	662838-001	Optional <sup>2</sup>
	p) 2.6-GHz 12C AMD Opteron™ Model 6238* **	654523-001	662837-001	Optional <sup>2</sup>
	q) 1.6-GHz 16C AMD Opteron™ Model 6262HE* **	654524-001	662841-001	Optional <sup>2</sup>
	r) 2.1-GHz 16C AMD Opteron™ Model 6272* **	654522-003	662836-001	Optional <sup>2</sup>
	s) 2.2-GHz 16C AMD Opteron™ Model 6274* **	654522-002	662835-001	Optional <sup>2</sup>
	t) 2.3-GHz 16C AMD Opteron™ Model 6276* **	654521-001	662834-001	Optional <sup>2</sup>
	u) 2.6-GHz 16C AMD Opteron™ Model 6282SE* **	654868-001	663779-001	Optional <sup>2</sup>
18	Processor heatsink, thermal grease, and alcohol pad, 80-Watt	579554-001	592068-001	Optional <sup>2</sup>
	<b>Boards</b>			
19	System board components	—	—	—
	a) System board assembly	570047-001	583981-001	Optional <sup>2</sup>
	b) System board assembly with subpan*	570047-002	669515-001	Optional <sup>2</sup>
20	Power supply backplane	462952-001	496062-001	Optional <sup>2</sup>
21	Hard drive backplane	—	—	—
	a) SFF SAS backplane	451283-002	507690-001	Optional <sup>2</sup>

Item	Description	Assembly part number	Spare part number	Customer self repair (on page 6)
	b) LFF SAS backplane*	457174-003	602510-001	Optional <sup>2</sup>
	c) 6-bay hard drive backplane*	457174-002	577427-001	Optional <sup>2</sup>
22	Systems Insight Display	570048-001	583984-001	Mandatory <sup>1</sup>
23	Controller board	013233-001	462919-001	Mandatory <sup>1</sup>
24	PCI riser boards*	—	—	—
	a) PCI-X	533537-001	583983-001	Mandatory <sup>1</sup>
	b) PCIe	533536-001	583982-001	Mandatory <sup>1</sup>
	c) Dual-port	451282-001	507688-001	Mandatory <sup>1</sup>
	<b>Memory</b>			
25	DIMMs*	—	—	—
	a) 2-GB, dual-rank, PC3-10600, registered	500202-161	595094-001	Mandatory <sup>1</sup>
	b) 2-GB, quad-rank, PC3-10600E	500209-161	595101-001	Mandatory <sup>1</sup>
	c) 4-GB, single-rank, PC3-10600, unbuffered	500210-171	595102-001	Mandatory <sup>1</sup>
	d) 4-GB, dual-rank, PC3-10600, registered	591750-171	595096-001	Mandatory <sup>1</sup>
	e) 8-GB, dual-rank, PC3-10600, registered	500205-171	595097-001	Mandatory <sup>1</sup>
	f) 8-GB, dual-rank, PC3L-10600, registered	605313-171	606425-001	Mandatory <sup>1</sup>
	g) 16-GB, dual-rank, PC3-8500, registered	500207-171	595098-001	Mandatory <sup>1</sup>
	<b>Cables</b>			
26	SAS backplane cable, 83.8 cm (33.0 in)*	463184-001	496070-001	Mandatory <sup>1</sup>
27	SATA DVD power cable*	463209-001	496071-001	Mandatory <sup>1</sup>
28	Mini-SAS to mini-SAS cable*	493228-006	498426-001	Mandatory <sup>1</sup>
29	Hard drive backplane power cable*	582248-001	602509-001	Mandatory <sup>1</sup>
30	AC power cord*	142263-001	142258-001	Mandatory <sup>1</sup>
31	Battery cable, 60 cm (24 in)*	458943-003	488138-001	Mandatory <sup>1</sup>
32	Miscellaneous cable kit*	—	602507-001	—
	a) Hard drive cable	582248-002	—	Mandatory <sup>1</sup>
	b) Systems Insight Display cable	582247-001	—	Mandatory <sup>1</sup>
	<b>Rack mounting hardware</b>			
33	Rack mounting hardware kit, LFF*	491732-001	574898-001	Optional <sup>2</sup>
34	Rack mounting hardware kit, SFF*	487267-001	574765-001	Optional <sup>2</sup>
	<b>Miscellaneous</b>			
35	Battery, 3.3-V, lithium*	166899-001	153099-001	Mandatory <sup>1</sup>
36	Power supply, 48V*	444049-001	451816-001	Optional <sup>2</sup>
	<b>Options</b>			
37	Hot-plug hard drive*	—	—	—
	a) 36-GB, SAS, 10,000-rpm, 6 cm (2.5-in)	375859-B21	376596-001	Mandatory <sup>1</sup>
	b) 72-GB, SAS, 10,000-rpm, 6 cm (2.5-in)	375861-B21	376597-001	Mandatory <sup>1</sup>

Item	Description	Assembly part number	Spare part number	Customer self repair (on page 6)
	c) 60-GB SFF SATA hard drive, 5,400-rpm, 1-yr warranty	379306-B21	382264-001	Mandatory <sup>1</sup>
38	Array controllers*	—	—	—
	a) Smart Array E200 Controller	012891-001	412799-001	Optional <sup>2</sup>
	b) Smart Array E200 Controller cache module, 64-MB	012970-001	412800-001	Optional <sup>2</sup>
	c) Smart Array E200 Controller cache module, 128-MB	012795-001	413486-001	Optional <sup>2</sup>
	d) Smart Array P400 Controller	013159-003	405831-001	Optional <sup>2</sup>
	e) Smart Array P410 Controller	013233-001	462919-001	Optional <sup>2</sup>
	f) Smart Array P411 Controller	013236-001	462918-001	Optional <sup>2</sup>
	g) Smart Array P400 Controller cache module, 256-MB	012764-004	405836-001	Optional <sup>2</sup>
	h) Smart Array P400 Controller cache module, 512-MB	012764-003	405835-001	Optional <sup>2</sup>
	i) Smart Array P400 Controller battery	381573-001	398648-001	Optional <sup>2</sup>
	j) Smart Array P400 Controller battery cable assembly, 24-in	408658-002	409125-001	Optional <sup>2</sup>
39	HP Trusted Platform Module*	450168-001	505836-001	No <sup>3</sup>
40	Flash-Backed Write Cache Module, 1-GB*	570501-002	505908-001	Mandatory <sup>1</sup>
41	Battery-Backed Module with cable*	571436-002	587324-001	Mandatory <sup>1</sup>

\*Not shown

\*\*All processors in this HP ProLiant server must have the same cache size, speed, number of cores, and rated maximum power consumption.

<sup>1</sup>Mandatory—Parts for which customer self repair is mandatory. If you request HP to replace these parts, you will be charged for the travel and labor costs of this service.

<sup>2</sup>Optional—Parts for which customer self repair is optional. These parts are also designed for customer self repair. If, however, you require that HP replace them for you, there may or may not be additional charges, depending on the type of warranty service designated for your product.

<sup>3</sup>No—Some HP parts are not designed for customer self repair. In order to satisfy the customer warranty, HP requires that an authorized service provider replace the part. These parts are identified as "No" in the Illustrated Parts Catalog.

<sup>1</sup>Mandatory: Obligatoire—Pièces pour lesquelles la réparation par le client est obligatoire. Si vous demandez à HP de remplacer ces pièces, les coûts de déplacement et main d'œuvre du service vous seront facturés.

<sup>2</sup>Optional: Facultatif—Pièces pour lesquelles la réparation par le client est facultative. Ces pièces sont également conçues pour permettre au client d'effectuer lui-même la réparation. Toutefois, si vous demandez à HP de remplacer ces pièces, l'intervention peut ou non vous être facturée, selon le type de garantie applicable à votre produit.

<sup>3</sup>No: Non—Certaines pièces HP ne sont pas conçues pour permettre au client d'effectuer lui-même la réparation. Pour que la garantie puisse s'appliquer, HP exige que le remplacement de la pièce soit effectué par un Mainteneur Agréé. Ces pièces sont identifiées par la mention "Non" dans le Catalogue illustré.

<sup>1</sup>Mandatory: Obbligatorie—Parti che devono essere necessariamente riparate dal cliente. Se il cliente ne affida la riparazione ad HP, deve sostenere le spese di spedizione e di manodopera per il servizio.

<sup>2</sup>Optional: Opzionali—Parti la cui riparazione da parte del cliente è facoltativa. Si tratta comunque di componenti progettati per questo scopo. Se tuttavia il cliente ne richiede la sostituzione ad HP, potrebbe dover sostenere spese addizionali a seconda del tipo di garanzia previsto per il prodotto.

<sup>3</sup>No: Non CSR—Alcuni componenti HP non sono progettati per la riparazione da parte del cliente. Per rispettare la garanzia, HP richiede che queste parti siano sostituite da un centro di assistenza autorizzato. Tali parti sono identificate da un "No" nel Catalogo illustrato dei componenti.

<sup>1</sup>Mandatory: Zwingend—Teile, die im Rahmen des Customer Self Repair Programms ersetzt werden müssen. Wenn Sie diese Teile von HP ersetzen lassen, werden Ihnen die Versand- und Arbeitskosten für diesen Service berechnet.

<sup>2</sup>Optional: Optional—Teile, für die das Customer Self Repair-Verfahren optional ist. Diese Teile sind auch für Customer Self Repair ausgelegt. Wenn Sie jedoch den Austausch dieser Teile von HP vornehmen lassen möchten, können bei diesem Service je nach den für Ihr Produkt vorgesehenen Garantiebedingungen zusätzliche Kosten anfallen.

<sup>3</sup>No: Kein—Einige Teile sind nicht für Customer Self Repair ausgelegt. Um den Garantieanspruch des Kunden zu erfüllen, muss das Teil von einem HP Servicepartner ersetzt werden. Im illustrierten Teilekatalog sind diese Teile mit „No“ bzw. „Nein“ gekennzeichnet.

<sup>1</sup>Mandatory: Obligatorio—componentes para los que la reparación por parte del usuario es obligatoria. Si solicita a HP que realice la sustitución de estos componentes, tendrá que hacerse cargo de los gastos de desplazamiento y de mano de obra de dicho servicio.

<sup>2</sup>Optional: Opcional— componentes para los que la reparación por parte del usuario es opcional. Estos componentes también están diseñados para que puedan ser reparados por el usuario. Sin embargo, si precisa que HP realice su sustitución, puede o no conllevar costes adicionales, dependiendo del tipo de servicio de garantía correspondiente al producto.

<sup>3</sup>No: No—Algunos componentes no están diseñados para que puedan ser reparados por el usuario. Para que el usuario haga valer su garantía, HP pone como condición que un proveedor de servicios autorizado realice la sustitución de estos componentes. Dichos componentes se identifican con la palabra "No" en el catálogo ilustrado de componentes.

<sup>1</sup>Mandatory: Verplicht—Onderdelen waarvoor Customer Self Repair verplicht is. Als u HP verzoekt deze onderdelen te vervangen, komen de reiskosten en het arbeidsloon voor uw rekening.

<sup>2</sup>Optional: Optioneel—Onderdelen waarvoor reparatie door de klant optioneel is. Ook deze onderdelen zijn ontworpen voor reparatie door de klant. Als u echter HP verzoekt deze onderdelen voor u te vervangen, kunnen daarvoor extra kosten in rekening worden gebracht, afhankelijk van het type garantieservice voor het product.

<sup>3</sup>No: Nee—Sommige HP onderdelen zijn niet ontwikkeld voor reparatie door de klant. In verband met de garantievooraarden moet het onderdeel door een geautoriseerde Service Partner worden vervangen. Deze onderdelen worden in de geïllustreerde onderdelencatalogus aangemerkt met "Nee".

<sup>1</sup>Mandatory: Obrigatória—Peças cujo reparo feito pelo cliente é obrigatório. Se desejar que a HP substitua essas peças, serão cobradas as despesas de transporte e mão-de-obra do serviço.

<sup>2</sup>Optional: Opcional—Peças cujo reparo feito pelo cliente é opcional. Essas peças também são projetadas para o reparo feito pelo cliente. No entanto, se desejar que a HP as substitua, pode haver ou não a cobrança de taxa adicional, dependendo do tipo de serviço de garantia destinado ao produto.

<sup>3</sup>No: Nenhuma—Algumas peças da HP não são projetadas para o reparo feito pelo cliente. A fim de cumprir a garantia do cliente, a HP exige que um técnico autorizado substitua a peça. Essas peças estão identificadas com a marca "No" (Não), no catálogo de peças ilustrado.



<sup>1</sup>Mandatory : 必須 - 顧客自己修理が必須の部品。当該部品について、もしもお客様がHPに交換作業を依頼される場合には、その修理サービスに関する交通費および人件費がお客様に請求されます。

<sup>2</sup>Optional : 任意 - 顧客自己修理が任意である部品。この部品も顧客自己修理用です。当該部品について、もしもお客様がHPに交換作業を依頼される場合には、お買い上げの製品に適用される保証サービス内容の範囲内においては、費用を負担していただくことなく保証サービスを受けることができます。

<sup>3</sup>No : 除外 - HP製品の一部の部品は、顧客自己修理用ではありません。製品の保証を継続するためには、HPまたはHP正規保守代理店による交換作業が必須となります。部品カタログには、当該部品が顧客自己修理除外品である旨が記載されています。

<sup>1</sup>Mandatory: 强制性的 — 要求客户必须自行维修的部件。如果您请求 HP 更换这些部件，则必须为该服务支付差旅费和人工费用。

<sup>2</sup>Optional: 可选的 — 客户可以选择是否自行维修的部件。这些部件也是为客户自行维修设计的。不过，如果您要求 HP 为您更换这些部件，则根据您的产品指定的保修服务类型，HP 可能收取或不再收取任何附加费用。

<sup>3</sup>No: 否 — 某些 HP 部件的设计并未考虑客户自行维修。为了满足客户保修的需要，HP 要求授权服务提供商更换相关部件。这些部件在部件图解目录中标记为“否”。

<sup>1</sup>Mandatory: 強制的 — 客戶自行維修所使用的零件是強制性的。如果您要求 HP 更換這些零件，HP 將會向您收取此服務所需的外出費用與勞動成本。

<sup>2</sup>Optional: 選購的 — 客戶自行維修所使用的零件是選購的。這些零件也設計用於客戶自行維修之用。不過，如果您要求 HP 為您更換，則可能需要也可能不需要負擔額外的費用，端視針對此產品指定的保固服務類型而定。

<sup>3</sup>No: 否 — 某些 HP 零件沒有消費者可自行維修的設計。為符合客戶保固，HP 需要授權的服務供應商更換零件。這些零件在圖示的零件目錄中，被標示為「否」。

<sup>1</sup> Mandatory: 필수 — 고객 셀프 수리가 의무 사항인 필수 부품. 사용자가 HP에 이 부품의 교체를 요청할 경우 이 서비스에 대한 출장비 및 작업비가 청구됩니다.

<sup>2</sup> Optional: 옵션 — 고객 셀프 수리가 선택 사항인 부품. 이 부품들도 고객 셀프 수리가 가능하도록 설계되었습니다. 하지만 사용자가 HP에 이 부품의 교체를 요청할 경우 사용자가 구입한 제품에 해당하는 보증 서비스 유형에 따라 추가 비용 없이 교체가 가능할 수 있습니다.

<sup>3</sup> No: No — 고객 셀프 수리가 불가능하도록 설계된 HP 부품. 이 부품들은 고객 셀프 수리가 불가능하도록 설계되었습니다. HP는 고객 보증을 만족시키기 위해 공인 서비스 제공업체를 통해 부품을 교체하도록 하고 있습니다.

---

# Removal and replacement procedures

## Required tools

You need the following items for some procedures:

- T-10/T-15 Torx screwdriver (provided inside the server)
- HP Insight Diagnostics software ("[HP Insight Diagnostics](#)" on page 79)

## Safety considerations

Before performing service procedures, review all the safety information.

## Preventing electrostatic discharge

To prevent damaging the system, be aware of the precautions you need to follow when setting up the system or handling parts. A discharge of static electricity from a finger or other conductor may damage system boards or other static-sensitive devices. This type of damage may reduce the life expectancy of the device.

To prevent electrostatic damage:

- Avoid hand contact by transporting and storing products in static-safe containers.
- Keep electrostatic-sensitive parts in their containers until they arrive at static-free workstations.
- Place parts on a grounded surface before removing them from their containers.
- Avoid touching pins, leads, or circuitry.
- Always be properly grounded when touching a static-sensitive component or assembly.

## Server warnings and cautions

Before installing a server, be sure that you understand the following warnings and cautions.



**WARNING:** To reduce the risk of electric shock or damage to the equipment:

- Do not disable the power cord grounding plug. The grounding plug is an important safety feature.
- Plug the power cord into a grounded (earthed) electrical outlet that is easily accessible at all times.
- Unplug the power cord from the power supply to disconnect power to the equipment.
- Do not route the power cord where it can be walked on or pinched by items placed against it. Pay particular attention to the plug, electrical outlet, and the point where the cord extends from the server.



**WARNING:** To reduce the risk of personal injury from hot surfaces, allow the drives and the internal system components to cool before touching them.

---



---

**CAUTION:** Do not operate the server for long periods with the access panel open or removed. Operating the server in this manner results in improper airflow and improper cooling that can lead to thermal damage.

---

## Preparation procedures

To access some components and perform certain service procedures, you must perform one or more of the following procedures:

- Extend the server from the rack (on page 28).  
If you are performing service procedures in an HP, Compaq branded, telco, or third-party rack cabinet, you can use the locking feature of the rack rails to support the server and gain access to internal components.  
For more information about telco rack solutions, refer to the RackSolutions.com website (<http://www.racksolutions.com/hp>).
- Power down the server (on page 27).  
If you must remove a server from a rack or a non-hot-plug component from a server, power down the server.
- Remove the server from the rack (on page 28).  
If the rack environment, cabling configuration, or the server location in the rack creates awkward conditions, remove the server from the rack.

## Power down the server



---

**WARNING:** To reduce the risk of personal injury, electric shock, or damage to the equipment, remove the power cord to remove power from the server. The front panel Power On/Standby button does not completely shut off system power. Portions of the power supply and some internal circuitry remain active until AC power is removed.

---



**IMPORTANT:** If installing a hot-plug device, it is not necessary to power down the server.

---

1. Back up the server data.
2. Shut down the operating system as directed by the operating system documentation.  
**NOTE:** If the operating system automatically places the server in Standby mode, omit the next step.
3. Press the Power On/Standby button to place the server in Standby mode. When the server activates Standby power mode, the system power LED changes to amber.



---

**IMPORTANT:** Pressing the UID button illuminates the blue UID LEDs on the front and rear panels. In a rack environment, this feature facilitates locating a server when moving between the front and rear of the rack.

---

4. Disconnect the power cords.

The system is now without power.

## Extend the server from the rack

1. Pull down the quick release levers on each side of the server.
2. Extend the server from the rack.



**WARNING:** To reduce the risk of personal injury or equipment damage, be sure that the rack is adequately stabilized before extending a component from the rack.

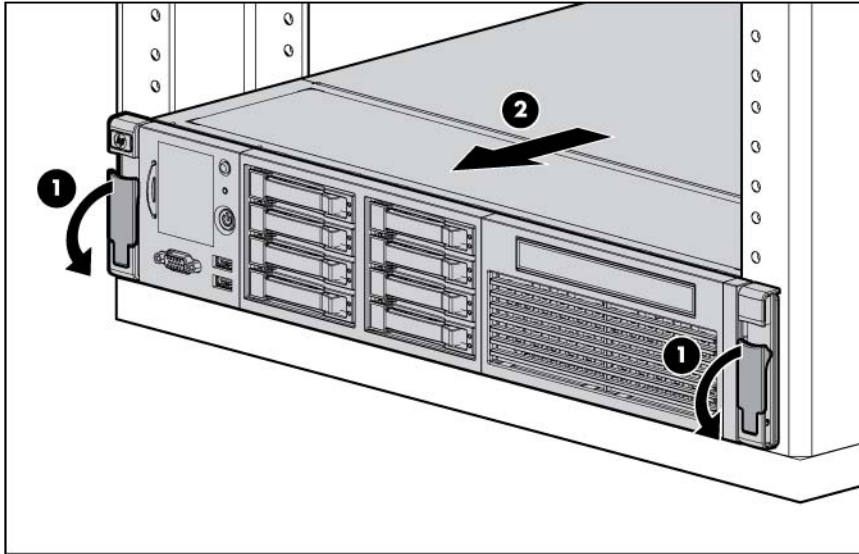

3. After performing the installation or maintenance procedure, slide the server back into the rack, and then press the server firmly into the rack to secure it in place.



**WARNING:** To reduce the risk of personal injury, be careful when pressing the server rail-release latches and sliding the server into the rack. The sliding rails could pinch your fingers.

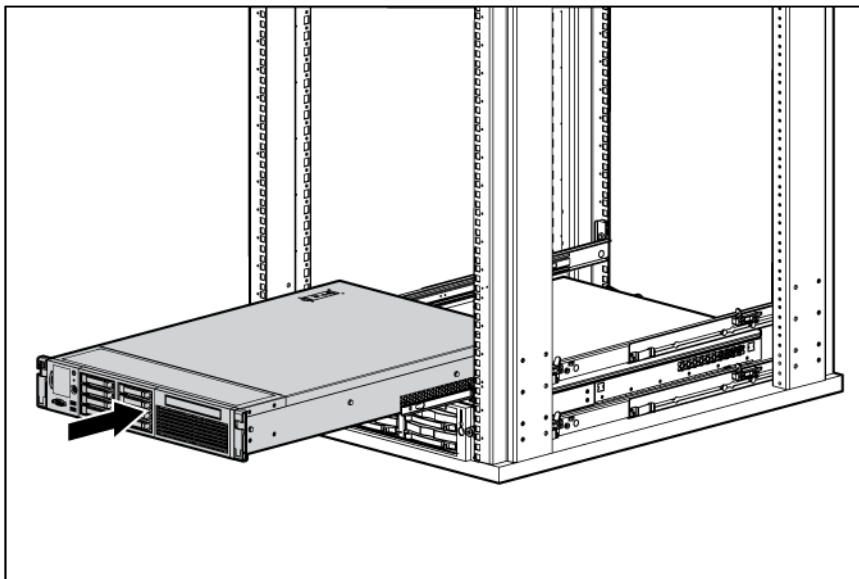

## Remove the server from the rack

To remove the server from an HP, Compaq branded, telco, or third-party rack:

1. Power down the server (on page 27).
2. Extend the server from the rack (on page 28).
3. Disconnect the cabling and remove the server from the rack. For more information, refer to the documentation that ships with the rack mounting option.
4. Place the server on a sturdy, level surface.

## Access the product rear panel

### Cable management arm with left-hand swing

To access the server rear panel:

1. Remove the cable arm retainer.

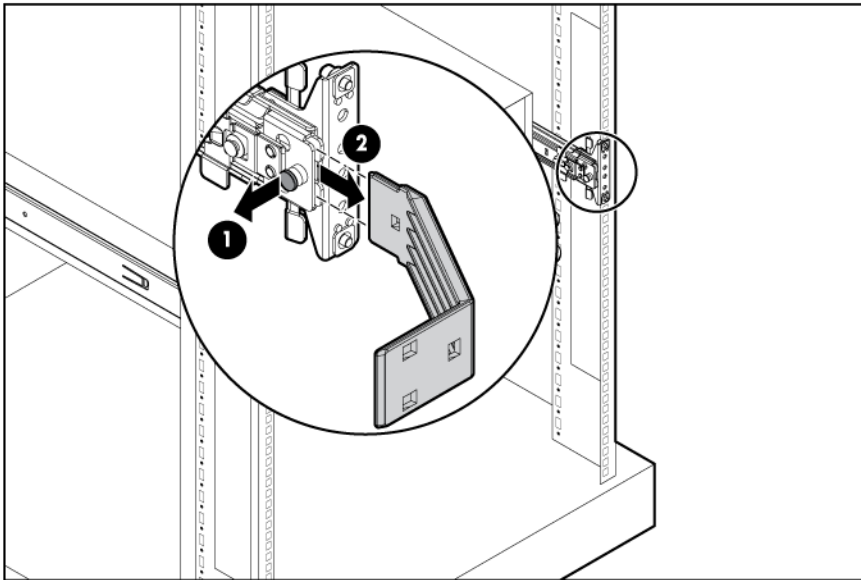

2. Open the cable management arm.

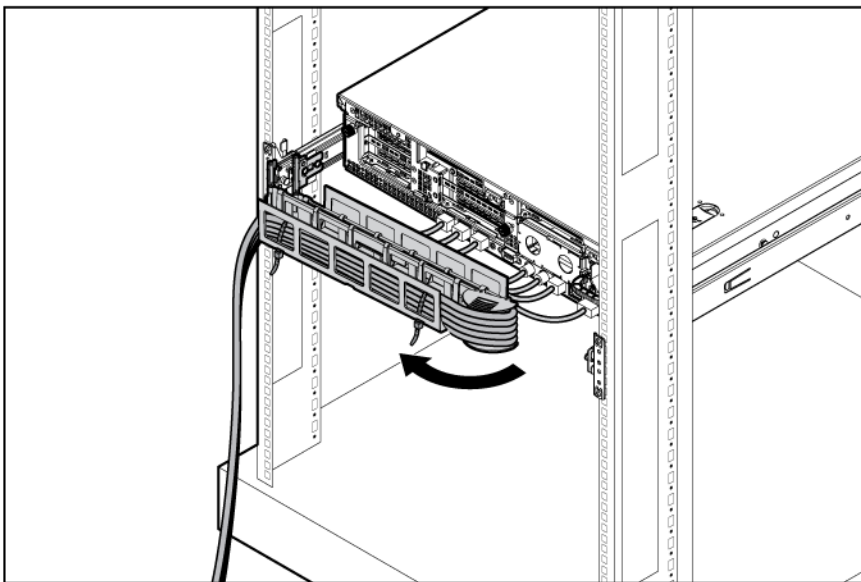

## Cable management arm with right-hand swing

**NOTE:** To access some components, you may need to remove the cable management arm.

To access the product rear panel components, open the cable management arm:

1. Power down the server (on page 27).
2. Swing open the cable management arm.
3. Remove the cables from the cable trough.
4. Remove the cable management arm.

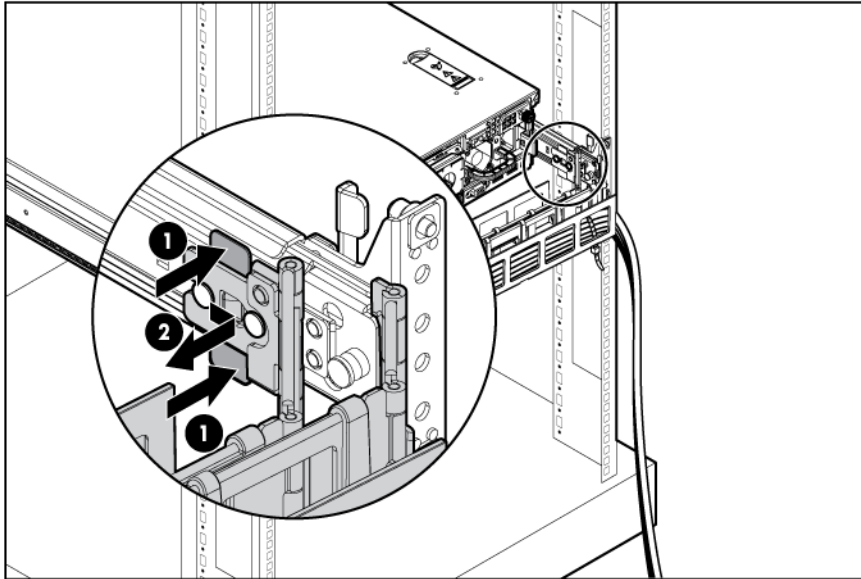

## SAS hard drive blank

△ **CAUTION:** For proper cooling do not operate the server without the access panel, baffles, expansion slot covers, or blanks installed. If the server supports hot-plug components, minimize the amount of time the access panel is open.

Remove the component as indicated.

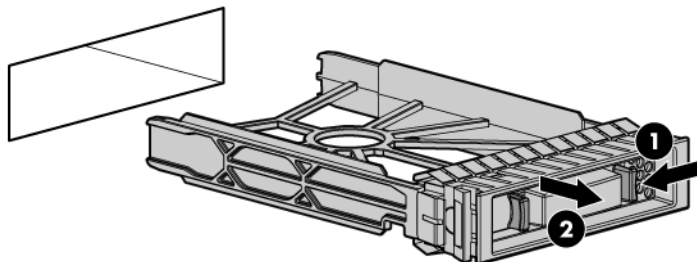

To replace the blank, slide the blank into the bay until it locks into place.

# Hot-plug SAS hard drive

To remove the component:

---

△ **CAUTION:** For proper cooling do not operate the server without the access panel, baffles, expansion slot covers, or blanks installed. If the server supports hot-plug components, minimize the amount of time the access panel is open.

---

1. Determine the status of the hard drive from the hot-plug SAS hard drive LED combinations ("SAS and SATA hard drive LED combinations" on page 90).
2. Back up all server data on the hard drive.
3. Remove the hard drive.

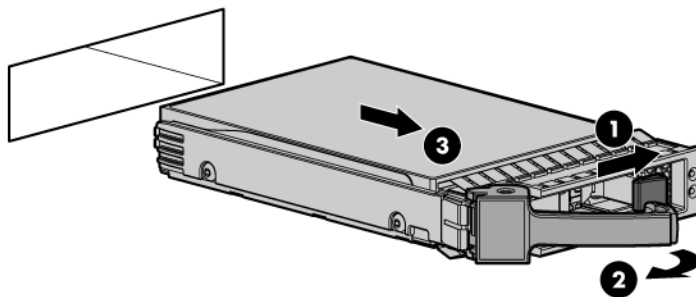

To replace the component, reverse the removal procedure.

# Power supply blank

To remove the component:

---

△ **CAUTION:** To prevent improper cooling and thermal damage, do not operate the server unless all bays are populated with either a component or a blank.

---

1. Access the product rear panel (on page 29).
2. Remove the power supply blank.

---

⚠ **WARNING:** To reduce the risk of personal injury from hot surfaces, allow the power supply or power supply blank to cool before touching it.

---

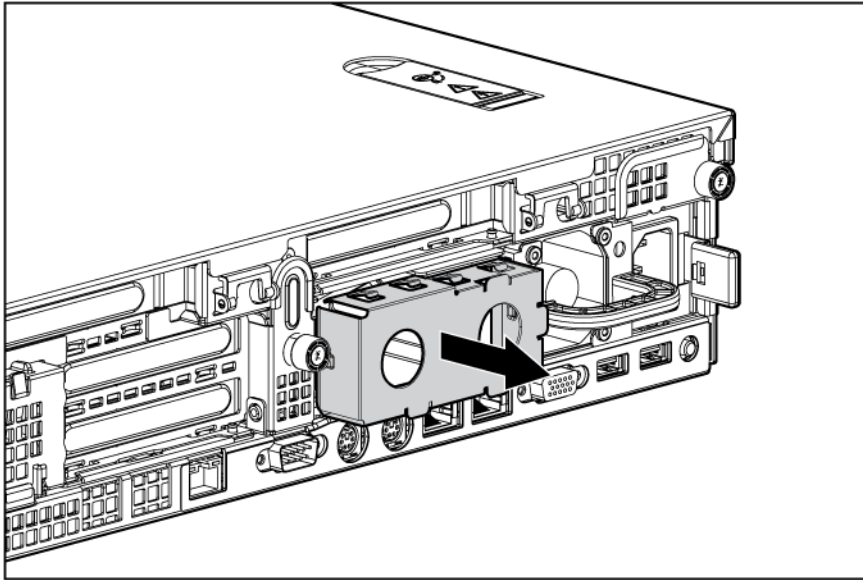

To replace the component, reverse the removal procedure.

## Hot-plug power supply

- 
- ⚠ **WARNING:** To reduce the risk of personal injury from hot surfaces, allow the power supply or power supply blank to cool before touching it.
- 
- ⚠ **CAUTION:** To prevent improper cooling and thermal damage, do not operate the server unless all bays are populated with either a component or a blank.
- 

To remove the component:

1. Determine how many hot-plug power supplies are installed:
  - If only one hot-plug power supply is installed, power down and remove the power cord from the server ("[Power down the server](#)" on page [27](#)).
  - If more than one hot-plug power supply is installed, continue with the next step.
2. Access the product rear panel (on page [29](#)).
3. Disconnect the power cord from the power supply.



4. Remove the hot-plug power supply.

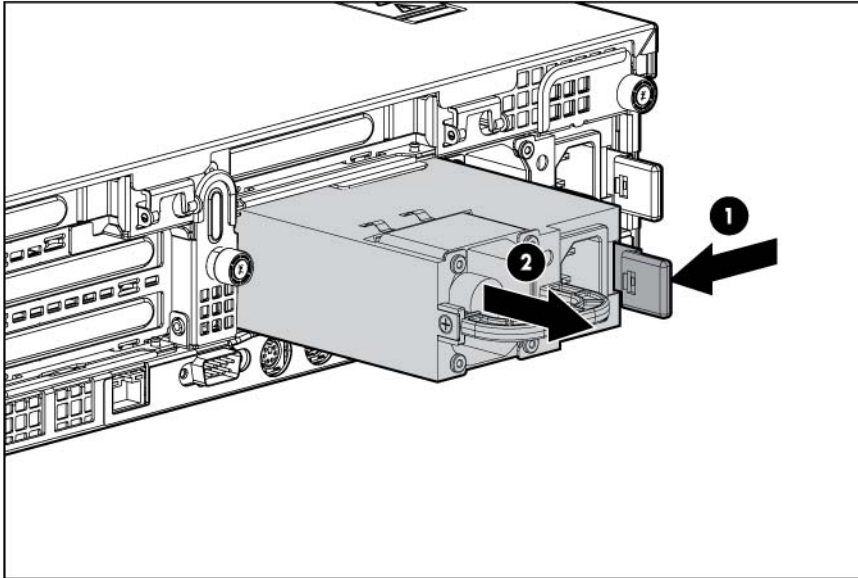

**WARNING:** To reduce the risk of electric shock or damage to the equipment, do not connect the power cord to the power supply until the power supply is installed.

To replace the component:

1. Slide the hot-plug power supply into the power supply bay.
2. Connect the power cord to the power supply.
3. Install the cable management arm, if removed ("[Access the product rear panel](#)" on page 29).
4. Route the power cord through the cable management arm or power cord anchor.

**NOTE:** If using the power cord anchor, be sure to leave enough slack in the power cord so that the redundant power supply can be removed without disconnecting the power cord from the primary power supply.

5. Close the cable management arm.
6. Connect the power cord to the power source.
7. Be sure that the power supply LED is green ("[Rear panel components](#)" on page 83, "[Systems Insight Display LEDs and health LED combinations](#)" on page 88, "[Rear panel LEDs and buttons](#)" on page 84).
8. Be sure that the front panel external health LED is green ("[Front panel LEDs and buttons](#)" on page 82).

## Front right bezel

To remove the component:

1. Extend or remove the server from the rack ("[Remove the server from the rack](#)" on page 28, "[Extend the server from the rack](#)" on page 28).

2. Remove the three T-10 Torx screws, and then detach the front bezel.

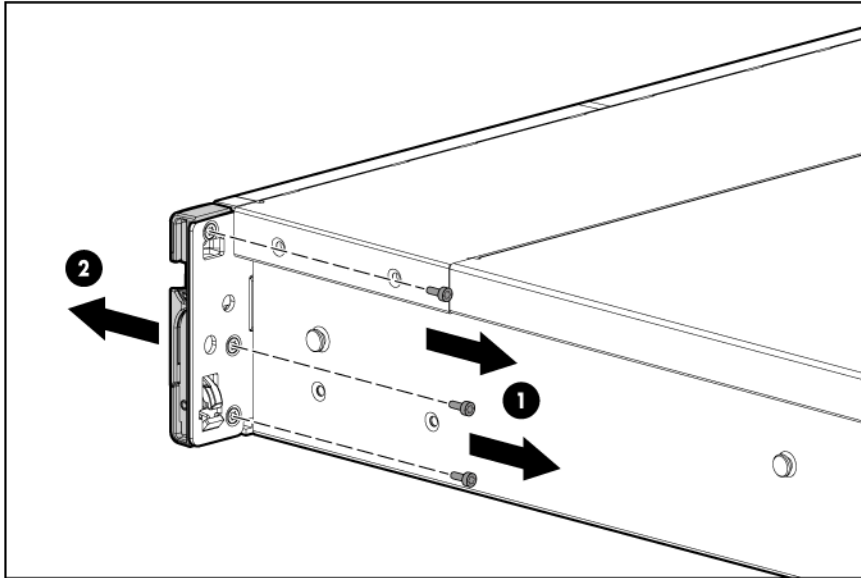

To replace the component, reverse the removal procedure.

## Access panel

- 
- ⚠ **WARNING:** To reduce the risk of personal injury from hot surfaces, allow the drives and the internal system components to cool before touching them.
- 
- ⚠ **CAUTION:** For proper cooling do not operate the server without the access panel, baffles, expansion slot covers, or blanks installed. If the server supports hot-plug components, minimize the amount of time the access panel is open.
- 

To remove the component:

1. Power down the server if performing a non-hot-plug installation or maintenance procedure ("[Power down the server](#)" on page [27](#)).
2. Extend the server from the rack (on page [28](#)).
3. Use the T-15 Torx screwdriver attached to the rear of the server to loosen the security screw on the hood latch.
4. Lift up on the hood latch handle, and then remove the access panel.

To replace the component, reverse the removal procedure.

## Optical drive

To remove the component:

- 
- ⚠ **CAUTION:** To prevent improper cooling and thermal damage, do not operate the server unless all bays are populated with either a component or a blank.
- 

1. Power down the server (on page [27](#)).

2. Extend or remove the server from the rack ("Remove the server from the rack" on page 28, "Extend the server from the rack" on page 28).
3. Remove the access panel ("Access panel" on page 34).
4. Disconnect the cable from the optical drive.

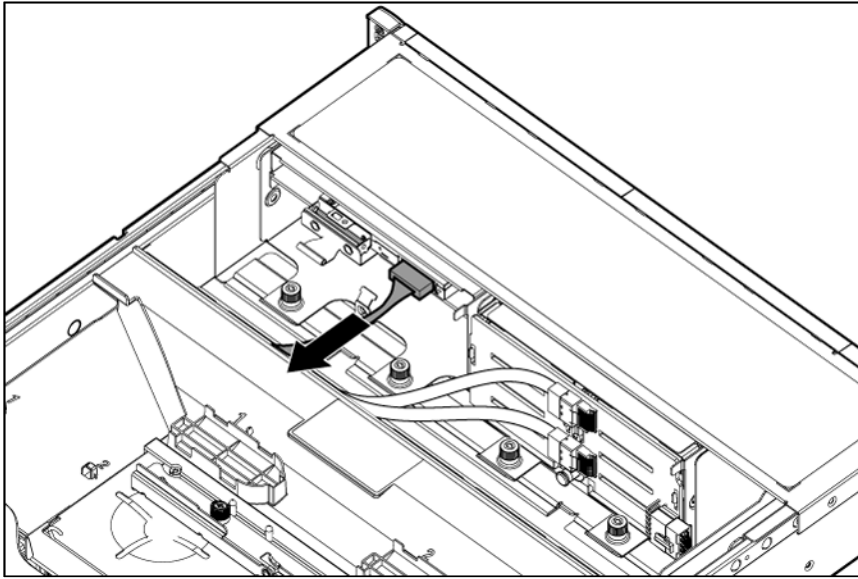

5. Remove the optical drive.

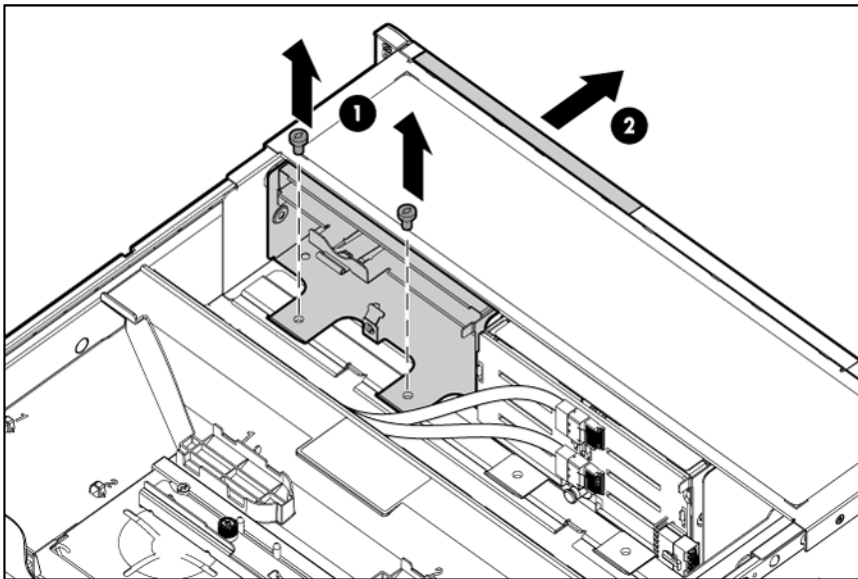

To replace the component, reverse the removal procedure.

## Optical drive cage

To remove the component:

**⚠ CAUTION:** To prevent improper cooling and thermal damage, do not operate the server unless all bays are populated with either a component or a blank.

1. Power down the server (on page 27).

2. Extend or remove the server from the rack ("[Remove the server from the rack](#)" on page 28, "[Extend the server from the rack](#)" on page 28).
3. Remove the access panel ("[Access panel](#)" on page 34).
4. Disconnect the cable from the optical drive.

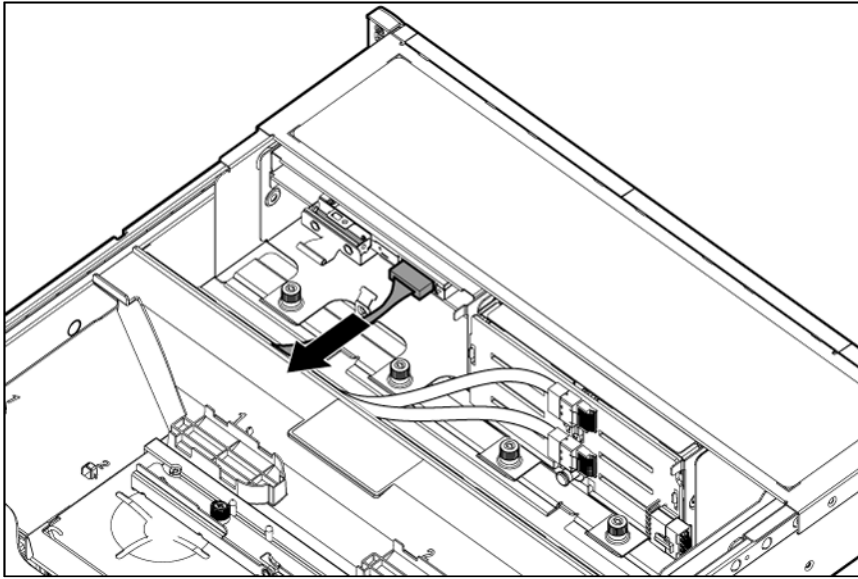

5. Remove the optical drive ("[Optical drive](#)" on page 34).
6. Remove the optical drive cage.

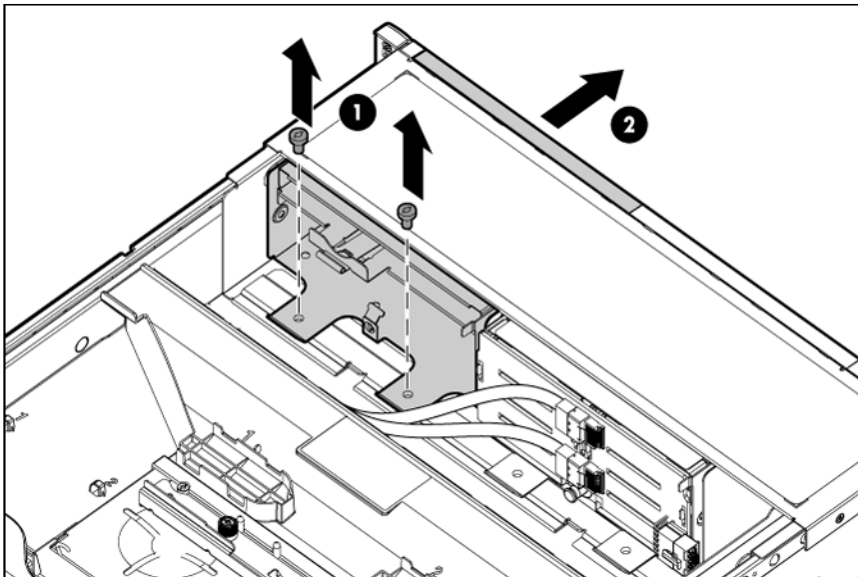

To replace the component, reverse the removal procedure.

## Hot-plug fan

- △ **CAUTION:** To avoid damage to server components, fan blanks must be installed in fan bays 5 and 6 in a single-processor configuration.

The only two valid fan configurations are listed in the following table.

Configuration	Fan bay 1	Fan bay 2	Fan bay 3	Fan bay 4	Fan bay 5	Fan bay 6
1 processor	Fan	Fan	Fan	Fan	Fan blank	Fan blank
2 processors	Fan	Fan	Fan	Fan	Fan	Fan

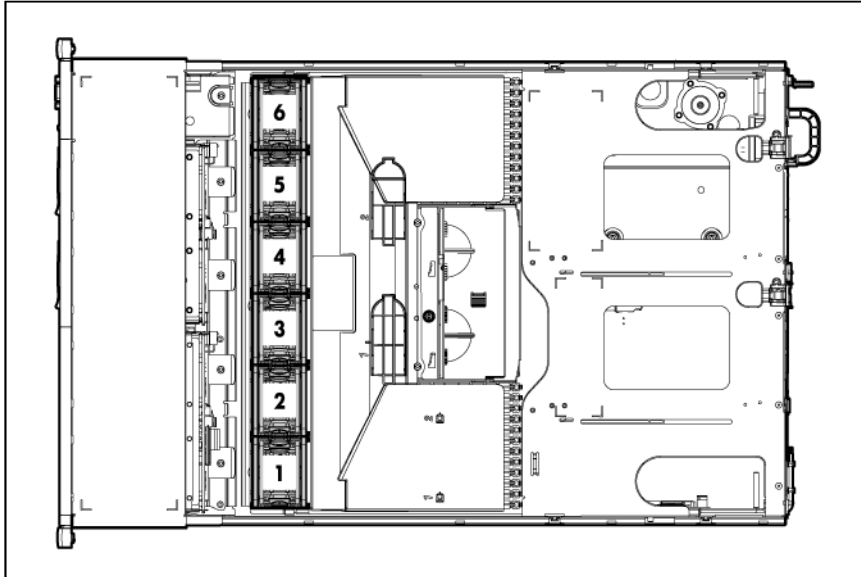

For a single-processor configuration, four fans and two blanks are required in specific fan bays for redundancy. A fan failure or missing fan causes all fans to spin at high speed. A second fan failure or missing fan causes an orderly shutdown of the server.

Installing more than the required number of fans in a single-processor configuration is not a thermally supported configuration.

For a dual-processor configuration, six fans are required for redundancy. A fan failure or missing fan causes all fans to spin at high speed. A second fan failure or missing fan causes an orderly shutdown of the server.

The server supports variable fan speed. The fans operate at minimum speed until a temperature change requires a fan speed increase to cool the server. The server shuts down during the following temperature-related scenarios:

- At POST and in the OS, iLO 3 performs an orderly shutdown if a cautionary temperature level is detected. If the server hardware detects a critical temperature level before an orderly shutdown occurs, the server performs an immediate shutdown.
- When the Thermal Shutdown feature is disabled in RBSU, iLO 3 does not perform an orderly shutdown when a cautionary temperature level is detected. Disabling this feature does not disable the server hardware from performing an immediate shutdown when a critical temperature level is detected.

**CAUTION:** A thermal event can damage server components when the Thermal Shutdown feature is disabled in RBSU.

To remove the component:

1. Extend or remove the server from the rack ("[Remove the server from the rack](#)" on page 28, "[Extend the server from the rack](#)" on page 28).
2. Remove the access panel ("[Access panel](#)" on page 34).

3. Remove the fan.

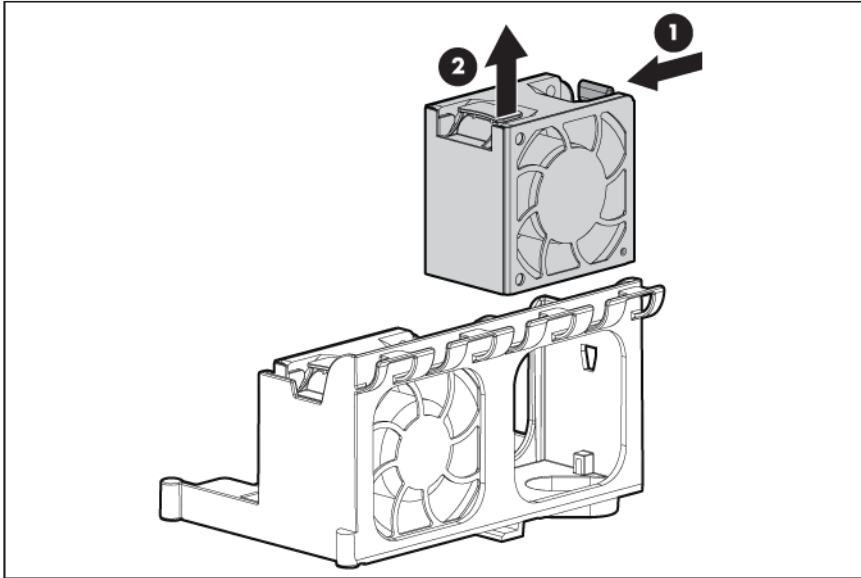

**CAUTION:** Do not operate the server for long periods with the access panel open or removed. Operating the server in this manner results in improper airflow and improper cooling that can lead to thermal damage.

To replace the component, reverse the removal procedure.

## Power supply backplane

To remove the component:

1. Power down the server (on page 27).
2. Remove all power supplies ("Hot-plug power supply" on page 32).
3. Extend the server from the rack (on page 28).
4. Remove the access panel ("Access panel" on page 34).

5. Remove the power supply backplane.

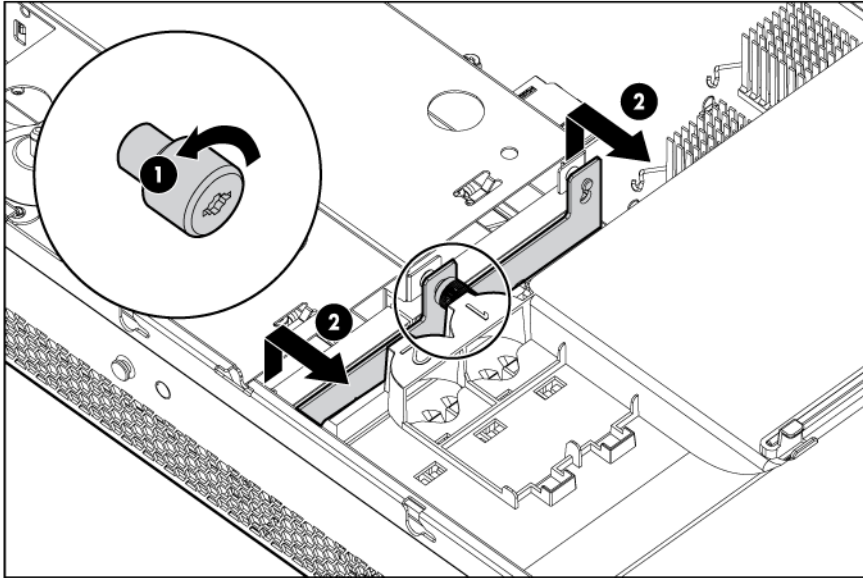

To replace the component, reverse the removal procedure.

## SFF hard drive backplane

To remove the component:

1. Power down the server (on page 27).
2. Extend or remove the server from the rack ("[Remove the server from the rack](#)" on page 28, "[Extend the server from the rack](#)" on page 28).
3. Remove the access panel ("[Access panel](#)" on page 34).
4. Remove all hot-plug hard drives ("[Hot-plug SAS hard drive](#)" on page 31).
5. Disconnect all cables from the hard drive backplane.

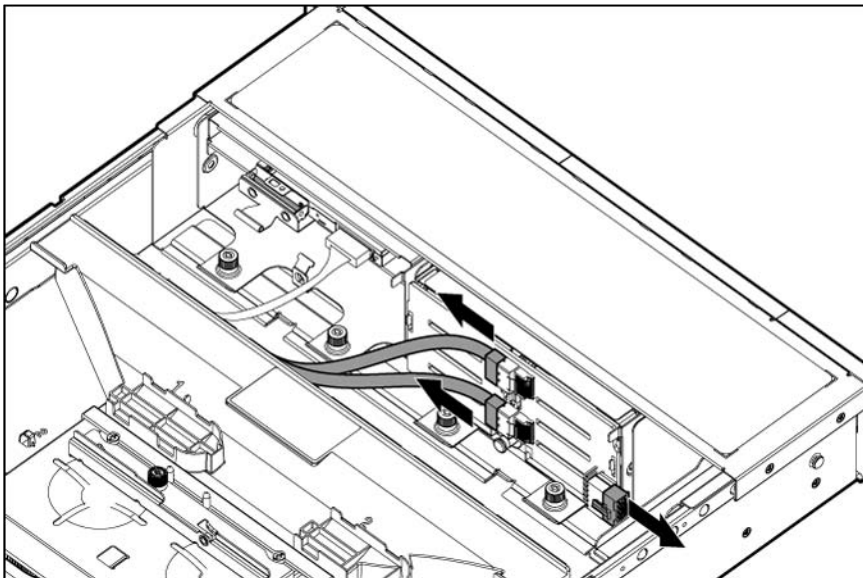



6. Remove the hard drive backplane.

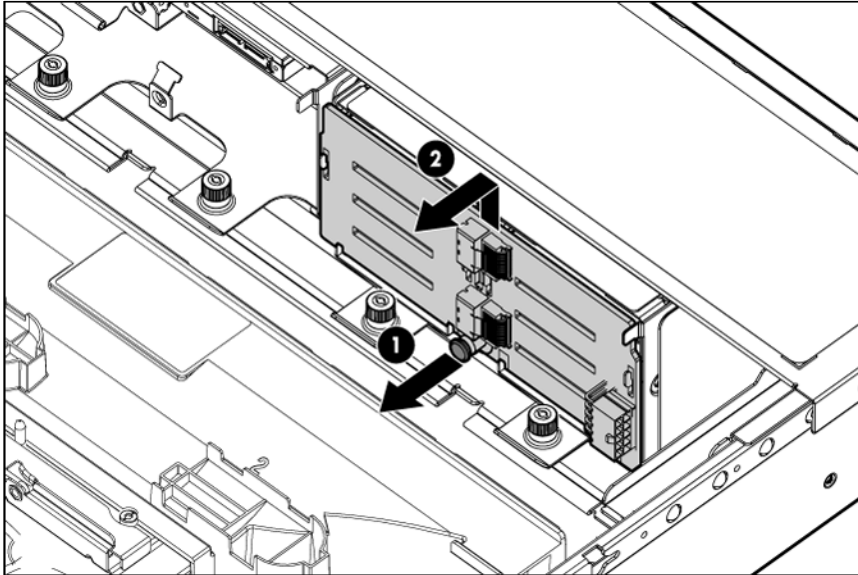

To replace the component, reverse the removal procedure.

## SFF hard drive cage

To remove the component:

1. Power down the server (on page 27).
2. Extend or remove the server from the rack ("[Remove the server from the rack](#)" on page 28, "[Extend the server from the rack](#)" on page 28).
3. Remove the access panel ("[Access panel](#)" on page 34).
4. Remove all hot-plug hard drives ("[Hot-plug SAS hard drive](#)" on page 31).
5. Disconnect all cables from the hard drive backplane.
6. Remove the hard drive backplane ("[SFF hard drive backplane](#)" on page 39).



7. Remove the hard drive cage.

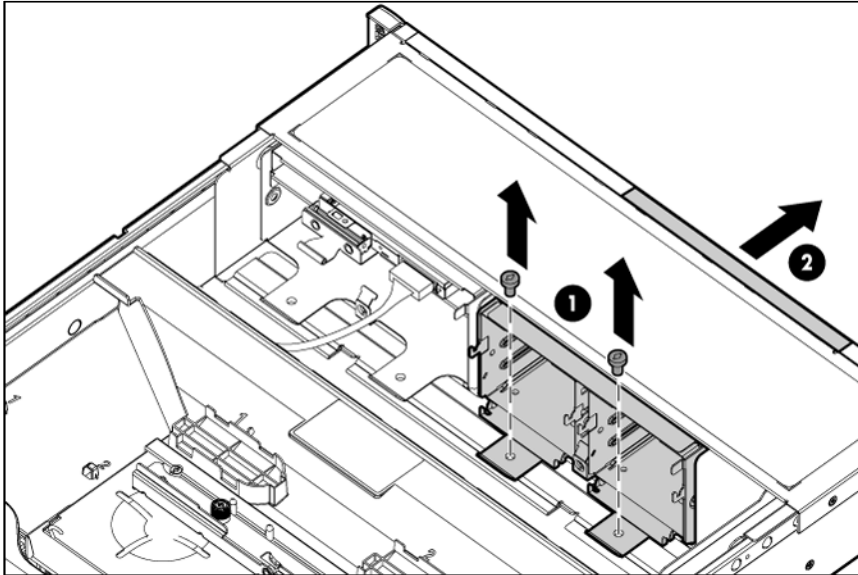

To replace the component, reverse the removal procedure.

## LFF hard drive backplane

To remove the component:

1. Power down the server (on page 27).
2. Extend or remove the server from the rack ("[Remove the server from the rack](#)" on page 28, "[Extend the server from the rack](#)" on page 28).
3. Remove the access panel ("[Access panel](#)" on page 34).
4. Remove all hot-plug hard drives ("[Hot-plug SAS hard drive](#)" on page 31).
5. Disconnect all cables from the hard drive backplane.

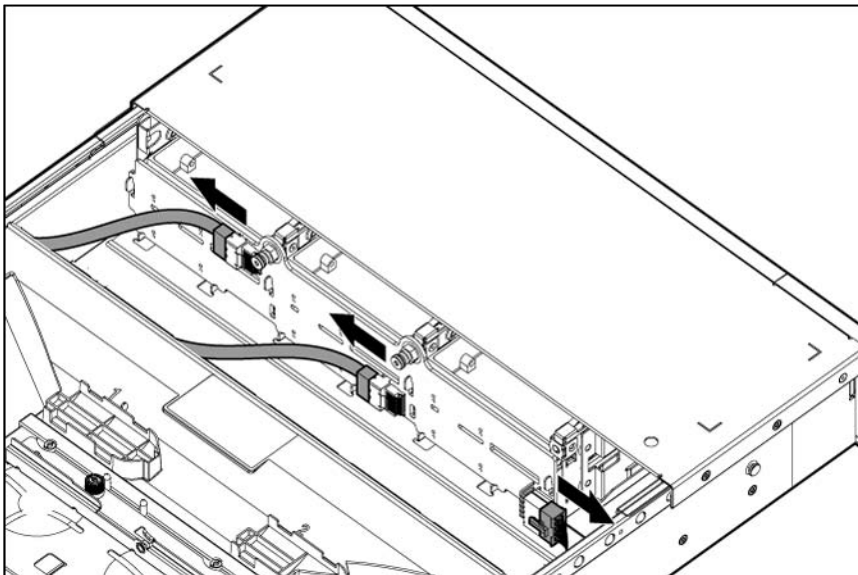

6. Remove the hard drive backplane.

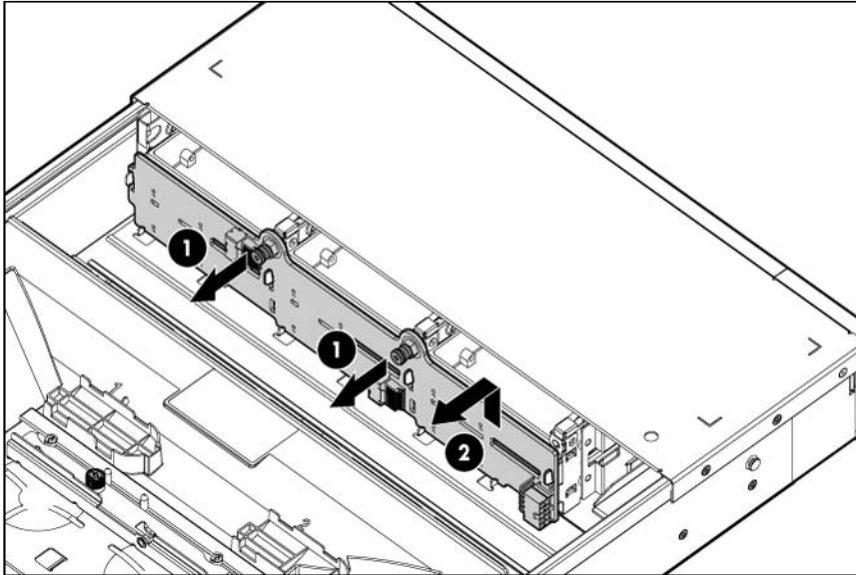

To replace the component, reverse the removal procedure.

## LFF hard drive cage

To remove the component:

1. Power down the server (on page 27).
2. Extend or remove the server from the rack ("[Remove the server from the rack](#)" on page 28, "[Extend the server from the rack](#)" on page 28).
3. Remove the access panel ("[Access panel](#)" on page 34).
4. Remove all hot-plug hard drives ("[Hot-plug SAS hard drive](#)" on page 31).
5. Disconnect all cables from the hard drive backplane.
6. Remove the hard drive backplane ("[LFF hard drive backplane](#)" on page 41).

7. Remove the hard drive cage.

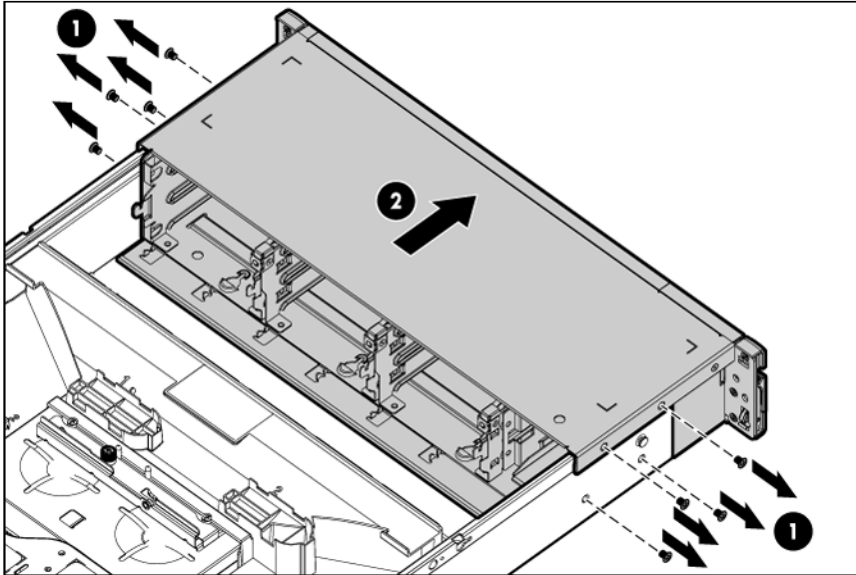

To replace the component, reverse the removal procedure.

## Full-length expansion board shipping bracket

**CAUTION:** To prevent damage to the server or expansion boards, power down the server and remove all AC power cords before removing or installing the PCI riser cage.

1. Power down the server (on page 27).
2. Extend the server from the rack (on page 28).
3. Remove the access panel ("Access panel" on page 34).
4. Remove the full-length expansion board shipping bracket:
  - If no full-length expansion boards are installed, remove the full-length expansion board shipping bracket as indicated.

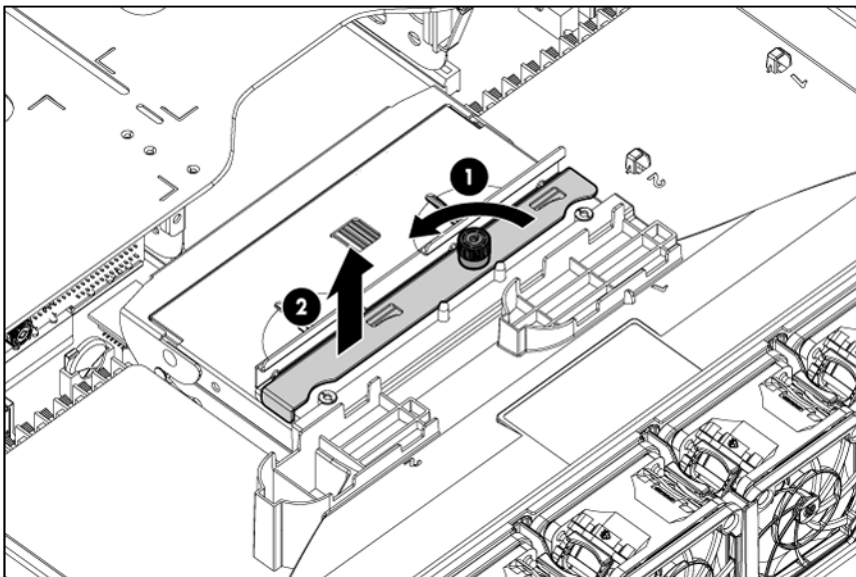

- If full-length expansion boards are installed, remove the full-length expansion board shipping bracket as indicated.

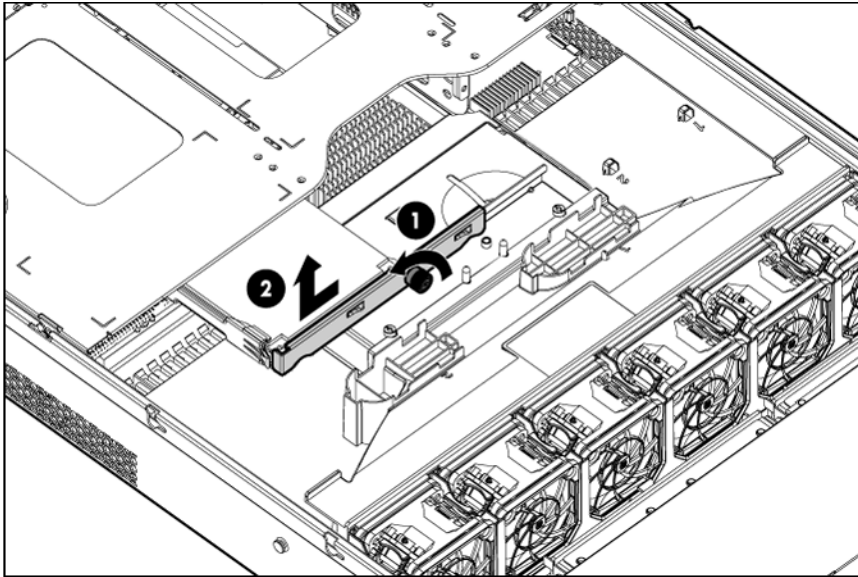

## PCI riser cage

To remove the component:

**CAUTION:** To prevent damage to the server or expansion boards, power down the server and remove all AC power cords before removing or installing the PCI riser cage.

1. Power down the server (on page 27).
2. Extend or remove the server from the rack ("[Remove the server from the rack](#)" on page 28, "[Extend the server from the rack](#)" on page 28).
3. Remove the access panel ("[Access panel](#)" on page 34).
4. If any full-length expansion boards are installed, remove the full-length expansion board shipping bracket ("[Full-length expansion board shipping bracket](#)" on page 43).

5. Remove the PCI riser cage.

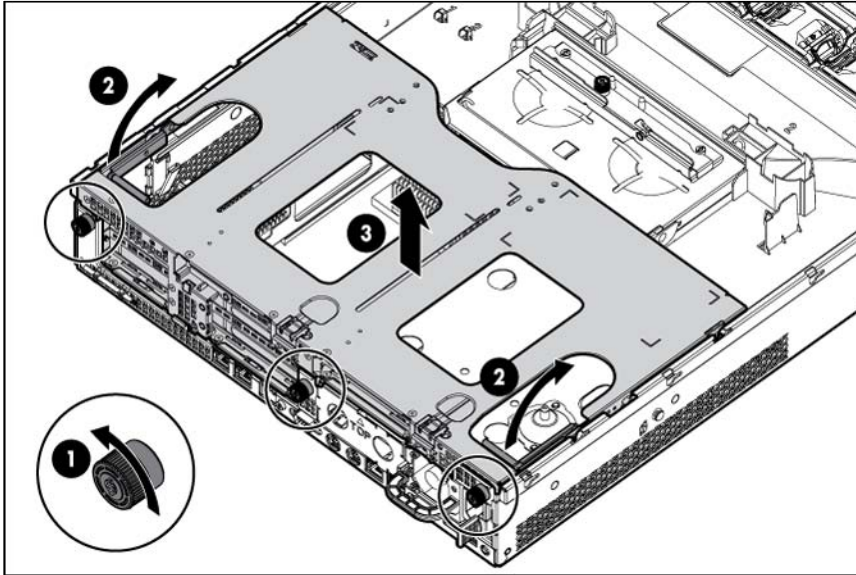

To replace the component, reverse the removal procedure.

## Expansion slot covers

---

△ **CAUTION:** To prevent damage to the server or expansion boards, power down the server and remove all AC power cords before removing or installing the PCI riser cage.

---

△ **CAUTION:** For proper cooling do not operate the server without the access panel, baffles, expansion slot covers, or blanks installed. If the server supports hot-plug components, minimize the amount of time the access panel is open.

---

1. Power down the server (on page 27).
2. Extend or remove the server from the rack ("[Remove the server from the rack](#)" on page 28, "[Extend the server from the rack](#)" on page 28).
3. Remove the access panel ("[Access panel](#)" on page 34).
4. If any full-length expansion boards are installed, remove the full-length expansion board shipping bracket ("[Full-length expansion board shipping bracket](#)" on page 43).
5. Remove the PCI riser cage ("[PCI riser cage](#)" on page 44).
6. Remove the expansion slot cover:

- To remove slot cover 1 or 4, push in on the retainer to release it, and then slide out the cover.

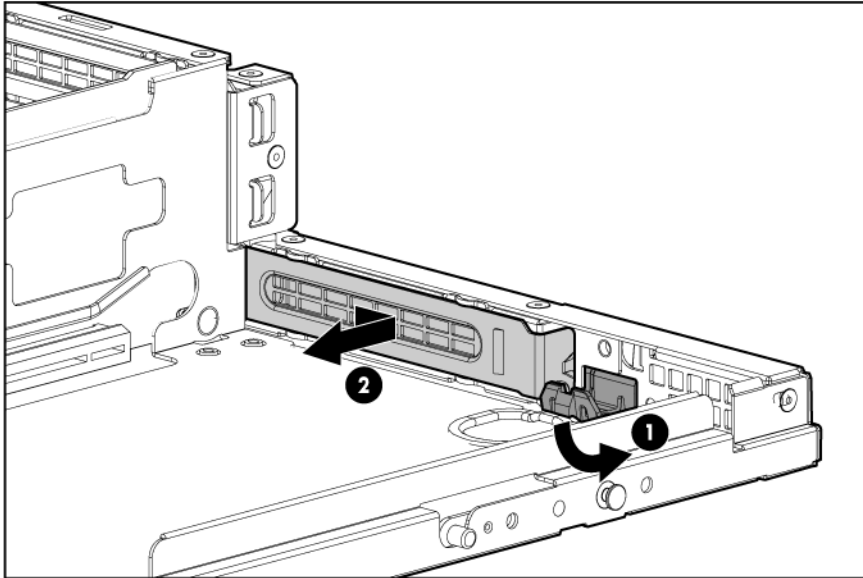

- To remove slot covers 2 and 3, lift up on the latch, remove the latch, and then remove the cover.

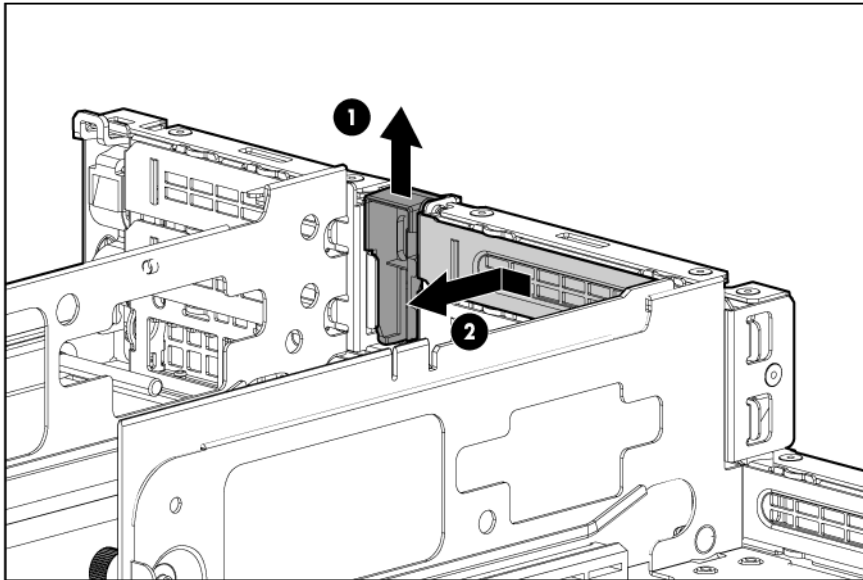



- To remove slot covers 5 and 6, push down on the latch, rotate the latch down, and then remove the cover.

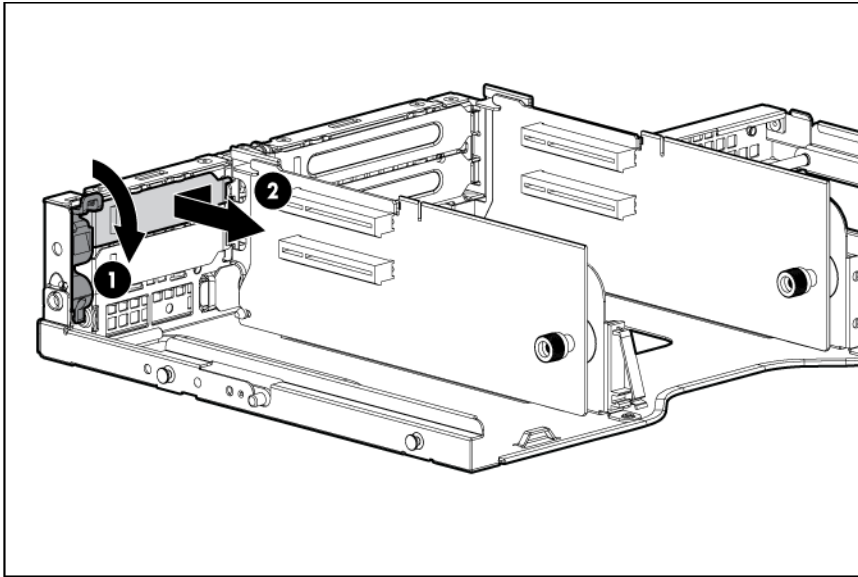

## Expansion boards

### Half-length expansion board

To remove the component:

1. Power down the server (on page 27).
2. Extend the server from the rack (on page 28).
3. Remove the access panel ("Access panel" on page 34).
4. Disconnect any external cables that are connected to the expansion board.
5. Remove the PCI riser cage ("PCI riser cage" on page 44).
6. Disconnect any internal cables that are connected to the expansion board.

7. Remove the expansion board.

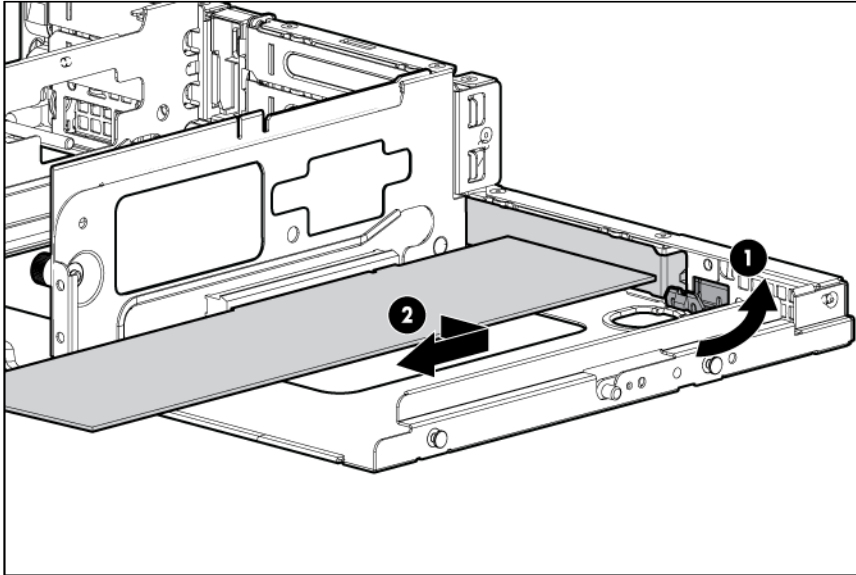

To replace the component, reverse the removal procedure.

## Full-length expansion board

To remove the component:

1. Power down the server (on page 27).
2. Extend the server from the rack (on page 28).
3. Remove the access panel ("Access panel" on page 34).
4. Disconnect any external cables that are connected to the expansion board.
5. Remove the PCI riser cage ("PCI riser cage" on page 44).
6. Disconnect any internal cables that are connected to the expansion board.
7. Remove the expansion board.

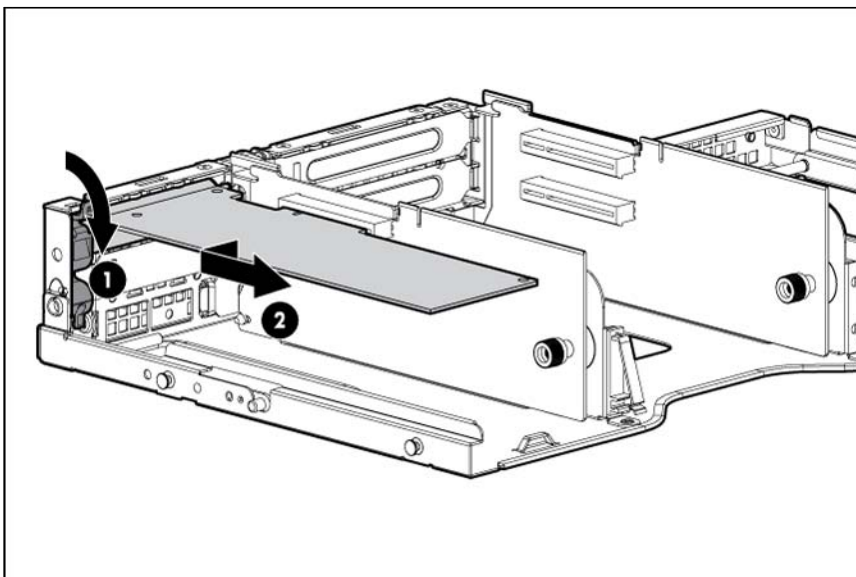



To replace the component, reverse the removal procedure.

## Air baffle

To remove the component:

**CAUTION:** For proper cooling do not operate the server without the access panel, baffles, expansion slot covers, or blanks installed. If the server supports hot-plug components, minimize the amount of time the access panel is open.

1. Power down the server (on page 27).
2. Extend or remove the server from the rack ("[Remove the server from the rack](#)" on page 28, "[Extend the server from the rack](#)" on page 28).
3. Remove the access panel ("[Access panel](#)" on page 34).

**CAUTION:** Do not detach the cable that connects the battery pack to the cache module. Detaching the cable causes any unsaved data in the cache module to be lost.

4. Remove the battery pack from the air baffle ("[Removing the battery pack](#)" on page 50).
5. Remove the air baffle.

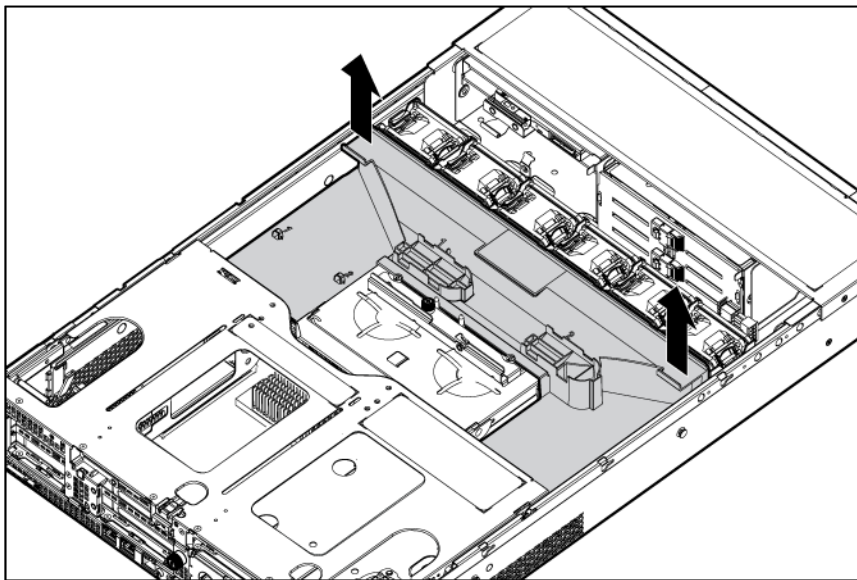

To replace the component, reverse the removal procedure.

## Battery-backed write cache procedures

Two types of procedures are provided for the BBWC option:

- Removal and replacement of failed components:
  - Removing the cache module (on page 50)
  - Removing the battery pack (on page 50)
- Recovery of cached data from a failed server ("[Recovering data from the battery-backed write cache](#)" on page 51)

---

**CAUTION:** Do not detach the cable that connects the battery pack to the cache module. Detaching the cable causes any unsaved data in the cache module to be lost.

---

## Removing the cache module

To remove the component:

1. Power down the server (on page 27).
2. Extend or remove the server from the rack ("[Remove the server from the rack](#)" on page 28, "[Extend the server from the rack](#)" on page 28).
3. Remove the access panel ("[Access panel](#)" on page 34).
4. Remove the PCI riser cage ("[PCI riser cage](#)" on page 44).
5. Remove the air baffle ("[Air baffle](#)" on page 49).
6. Remove the cache module.

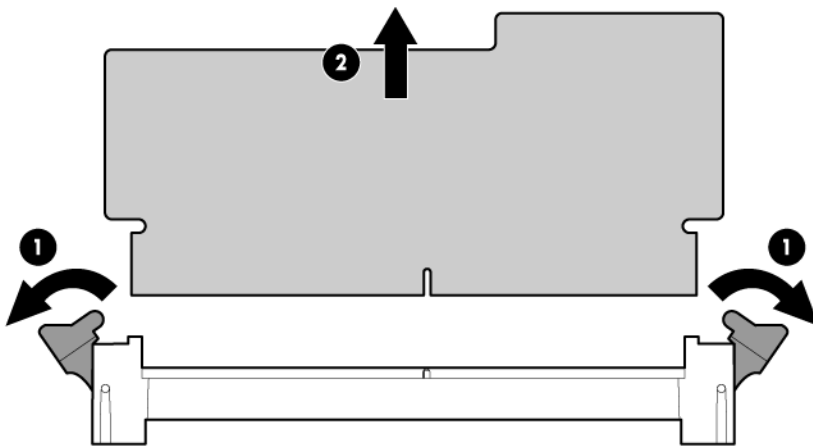

To replace the component, reverse the removal procedure.

---

**CAUTION:** To prevent damage to the cache module during installation, be sure the cache module is fully inserted before pressing down.

---

## Removing the battery pack

To remove the component:

1. Power down the server (on page 27).
2. Extend or remove the server from the rack ("[Remove the server from the rack](#)" on page 28, "[Extend the server from the rack](#)" on page 28).
3. Remove the access panel ("[Access panel](#)" on page 34).
4. Remove the PCI riser cage ("[PCI riser cage](#)" on page 44).

5. Disconnect the cable, and then remove the battery pack.

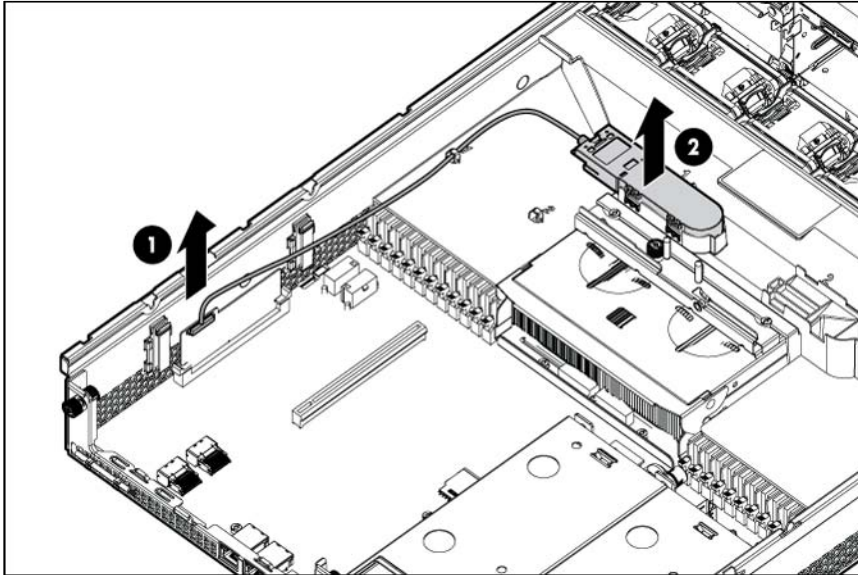

To replace the component, reverse the removal procedure.

## Recovering data from the battery-backed write cache

If the server fails, use the following procedure to recover data temporarily stored in the BBWC.

**CAUTION:** Before starting this procedure, read the information about protecting against electrostatic discharge ("Preventing electrostatic discharge" on page 26).

1. Perform one of the following:
  - o Set up a recovery server station using an identical server model. Do not install any internal drives or BBWC in this server. (HP recommends this option.)
  - o Find a server that has enough empty drive bays to accommodate all the drives from the failed server and that meets all the other requirements for drive and array migration.
2. Power down the failed server ("Power down the server" on page 27). If any data is stored in the cache module, a green LED on the module flashes every 2 seconds.

**CAUTION:** Do not detach the cable that connects the battery pack to the cache module. Detaching the cable causes any unsaved data in the cache module to be lost.

3. Transfer the hard drives from the failed server to the recovery server station.
4. Perform one of the following:
  - o If the array controller has failed, remove the cache module ("Removing the cache module" on page 50) and battery pack ("Removing the battery pack" on page 50) from the failed array controller, and install the cache module and battery pack on an array controller in the recovery server.
  - o If the server has failed, remove the controller ("Half-length expansion board" on page 47, "Full-length expansion board" on page 48), cache module ("Removing the cache module" on page 50), and battery pack ("Removing the battery pack" on page 50) from the failed server, and install the controller, cache module, and battery pack in the recovery server.

5. Power up the recovery server. A 1759 POST message is displayed, stating that valid data was flushed from the cache. This data is now stored on the drives in the recovery server. You can now transfer the drives (and controller, if one was used) to another server.

## Flash-backed write cache procedures

Two types of procedures are provided for the FBWC option:

- Removal and replacement of failed components:
  - Removing the cache module
  - Removing the capacitor pack ("[Flash-backed write cache capacitor pack](#)" on page 53)
- Recovery of cached data from a failed server ("[Recovering data from the battery-backed write cache](#)" on page 51)

---

△ **CAUTION:** Do not detach the cable that connects the battery pack or capacitor pack to the cache module. Detaching the cable causes any unsaved data in the cache module to be lost.

---

## Flash-backed write cache module

To remove the component:

---

△ **CAUTION:** Do not use this controller with cache modules designed for other controller models, because the controller can malfunction and you can lose data. Also, do not transfer this cache module to a different controller module, because you can lose data.

---

1. Back up all data.
2. Close all applications.
3. Power down the server (on page 27).

---

△ **CAUTION:** In systems that use external data storage, be sure that the server is the first unit to be powered down and the last to be powered back up. Taking this precaution ensures that the system does not erroneously mark the drives as failed when the server is powered up.

---

4. Extend the server from the rack (on page 28).
5. Remove the access panel ("[Access panel](#)" on page 34).
6. Remove the PCI riser cage ("[PCI riser cage](#)" on page 44)
7. If the existing cache module is connected to a capacitor pack, observe the FBWC module LEDs (on page 94):
  - If the amber LED is flashing, data is trapped in the cache. Restore system power, and restart this procedure from step 1.
  - If the amber LED is not illuminated, remove the controller from the server, and then continue with the next step.

8. Open the ejector latches on each side of the cache module connector. Normally, the cache module is ejected from the cache module connector. If the module is not ejected automatically, remove the cache module.

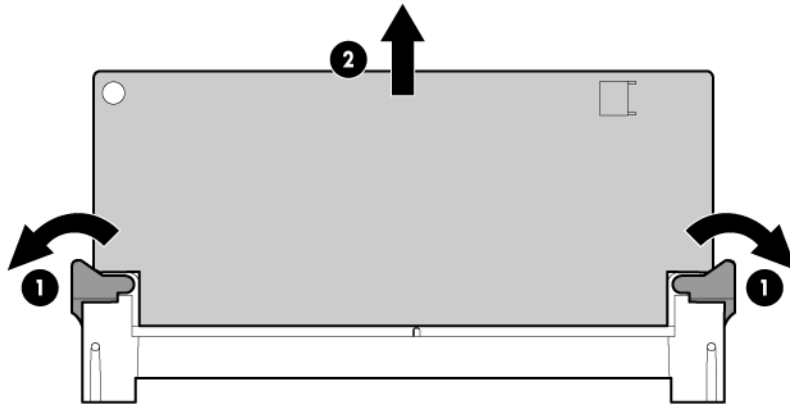

9. If the cache module is connected to a capacitor pack, disconnect the capacitor pack cable from the connector on the top of the cache module.

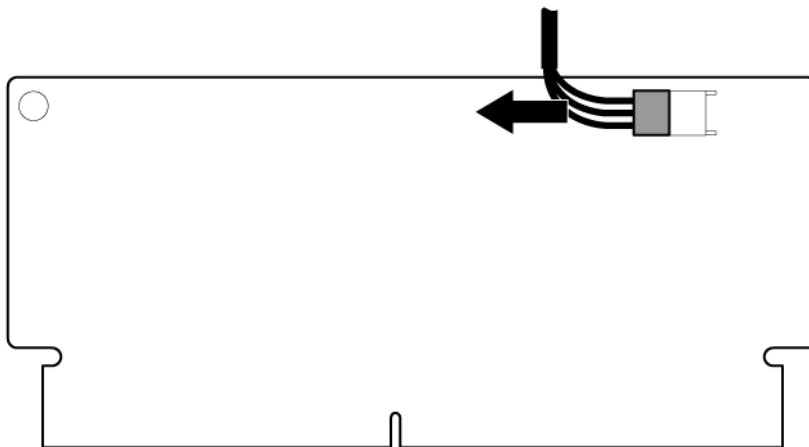

To replace the component, reverse the removal procedure.

- CAUTION:** To prevent damage to the cache module during installation, be sure the cache module is fully inserted before pressing down.

## Flash-backed write cache capacitor pack

To remove the component:

1. Back up all data.
2. Close all applications.
3. Power down the server (on page 27).

**⚠ CAUTION:** In systems that use external data storage, be sure that the server is the first unit to be powered down and the last to be powered back up. Taking this precaution ensures that the system does not erroneously mark the drives as failed when the server is powered up.

4. Extend the server from the rack (on page 28).
5. Remove the access panel ("Access panel" on page 34).
6. Remove the PCI riser cage ("PCI riser cage" on page 44).
7. If the capacitor pack is connected to the cache module, disconnect the capacitor pack cable from the connector on the top of the cache module.

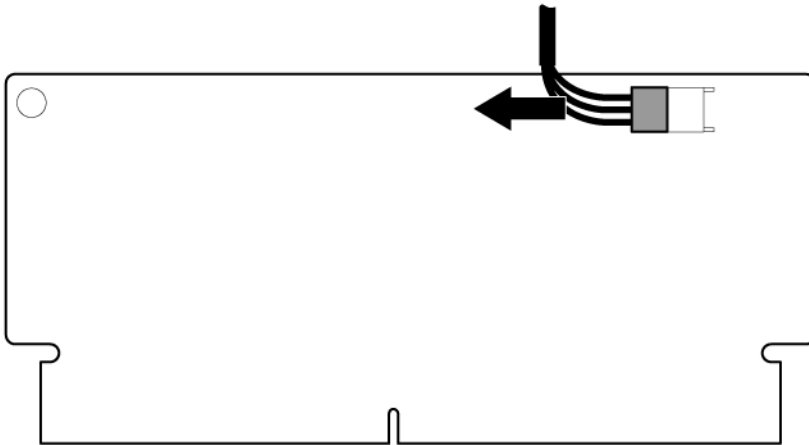

8. Disconnect the capacitor pack from the air baffle.

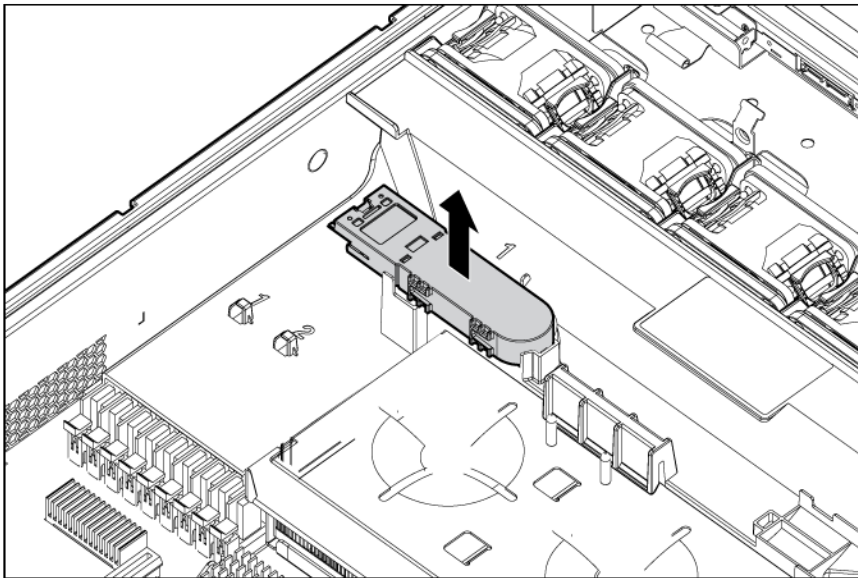

To replace the component, reverse the removal procedure.

## Fan cage

To remove the component:

1. Power down the server (on page 27).

2. Extend or remove the server from the rack ("[Remove the server from the rack](#)" on page 28, "[Extend the server from the rack](#)" on page 28).
3. Remove the access panel ("[Access panel](#)" on page 34).
4. Remove the PCI riser cage ("[PCI riser cage](#)" on page 44).
5. Remove the air baffle ("[Air baffle](#)" on page 49).
6. Remove the fan blanks.
7. Remove the fans ("[Hot-plug fan](#)" on page 36).
8. Remove the fan cage.

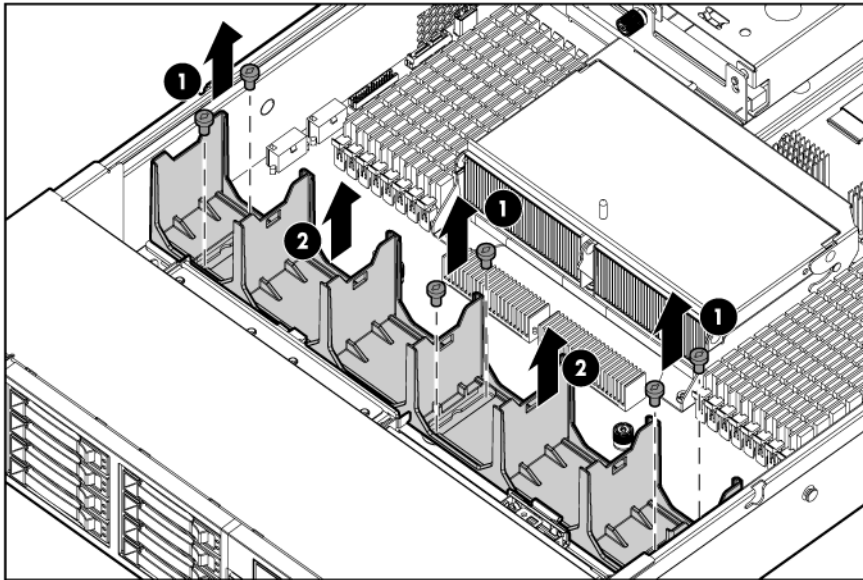

To replace the component, reverse the removal steps. Press down on the top of each fan to be sure it is seated properly.

## Heatsink

To remove the heatsink:

1. Power down the server (on page 27).
2. Extend or remove the server from the rack ("[Remove the server from the rack](#)" on page 28, "[Extend the server from the rack](#)" on page 28).
3. Remove the access panel ("[Access panel](#)" on page 34).
4. Remove the PCI riser cage ("[PCI riser cage](#)" on page 44).
5. Remove the air baffle ("[Air baffle](#)" on page 49).

6. Open the heatsink retaining bracket, and then remove the heatsink.

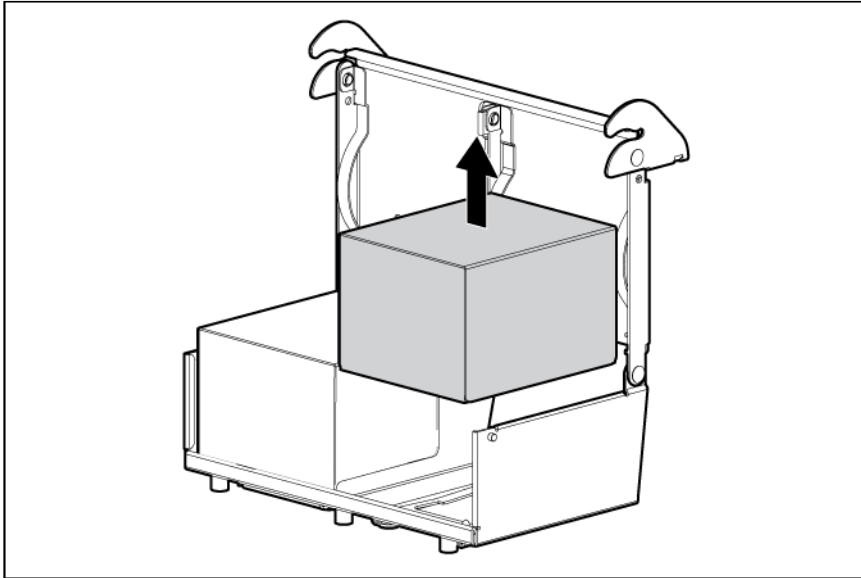

To replace the heatsink:

1. Clean the old thermal grease from the processor with the alcohol swab. Allow the alcohol to evaporate before continuing.
2. Remove the heatsink protective cover.

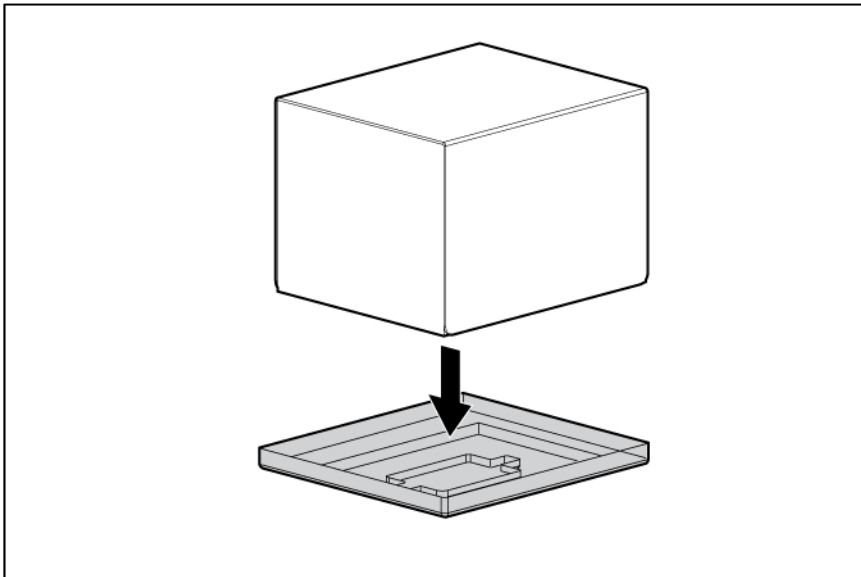



3. Install the heatsink.

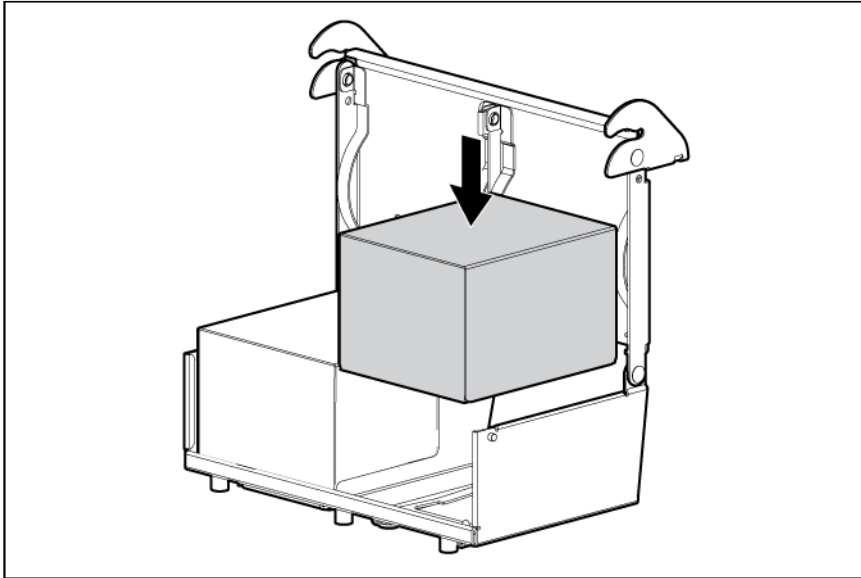

4. Close and lock the heatsink retaining latches.

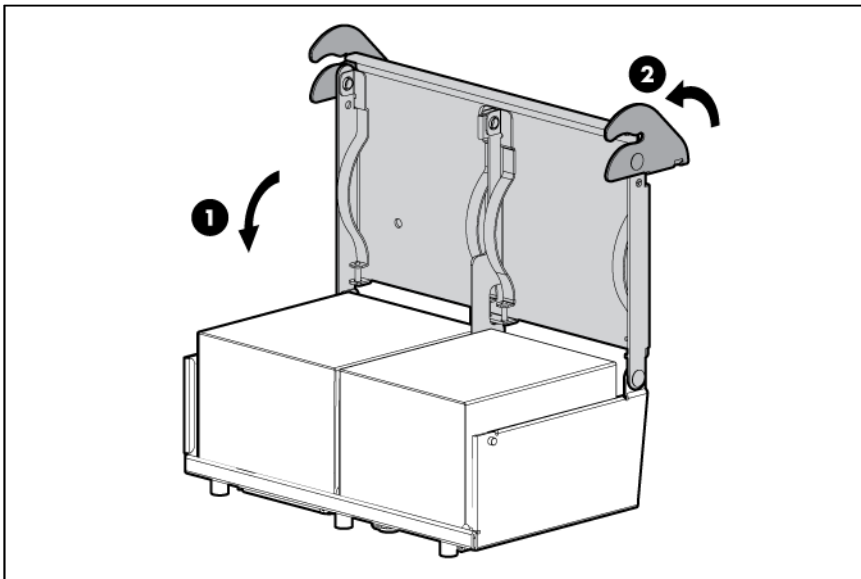

5. Install the air baffle ("Air baffle" on page 49).
6. Install the PCI riser cage ("PCI riser cage" on page 44).
7. Install the access panel ("Access panel" on page 34).
8. Install the server into the rack.
9. Power up the server.

## Processor



**CAUTION:** To avoid damage to the processor and system board, only authorized personnel should attempt to replace or install the processor in this server.



**CAUTION:** To prevent possible server malfunction and damage to the equipment, multiprocessor configurations must contain processors with the same part number.

To remove a processor:

1. Power down the server (on page 27).
2. Extend or remove the server from the rack ("[Remove the server from the rack](#)" on page 28, "[Extend the server from the rack](#)" on page 28).
3. Remove the access panel ("[Access panel](#)" on page 34).
4. Remove the PCI riser cage ("[PCI riser cage](#)" on page 44).
5. Remove the air baffle ("[Air baffle](#)" on page 49).
6. Open the processor socket retaining bracket and the processor locking lever.

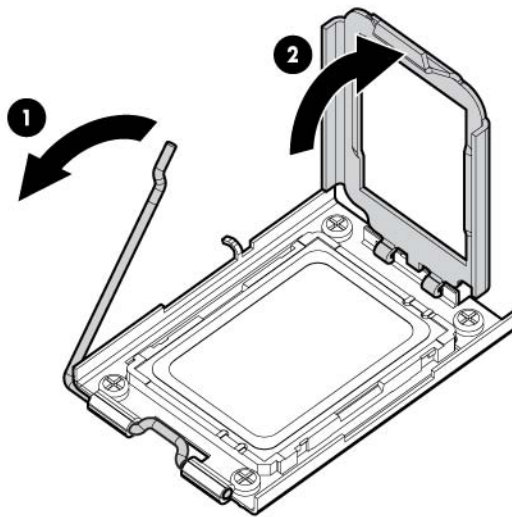

7. Using the processor tool, remove the processor from the system board.

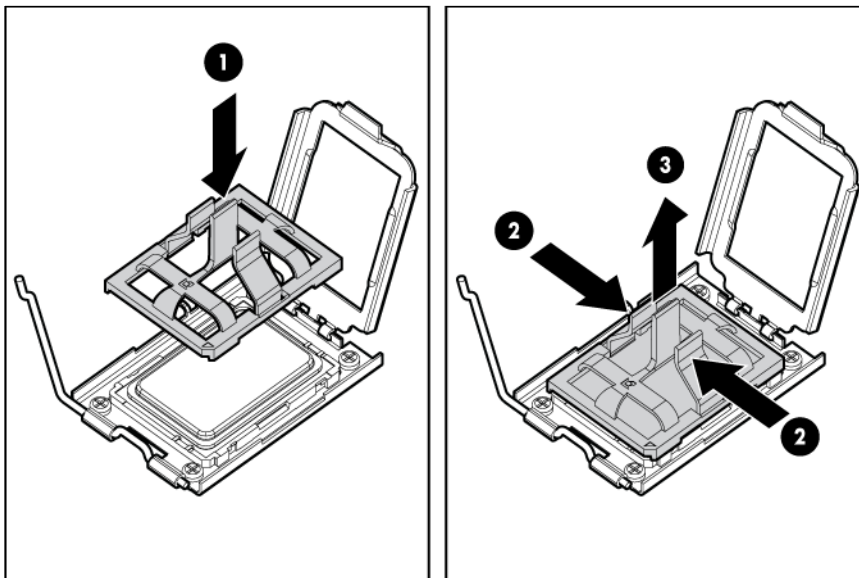



**CAUTION:** To avoid damage to the processor, do not touch the bottom of the processor, especially the contact area.

To replace a processor:



**IMPORTANT:** Be sure the processor remains inside the processor installation tool.

1. If the processor has separated from the installation tool, carefully re-insert the processor in the tool. Handle the processor by the edges only, and do not touch the bottom of the processor, especially the contact area.

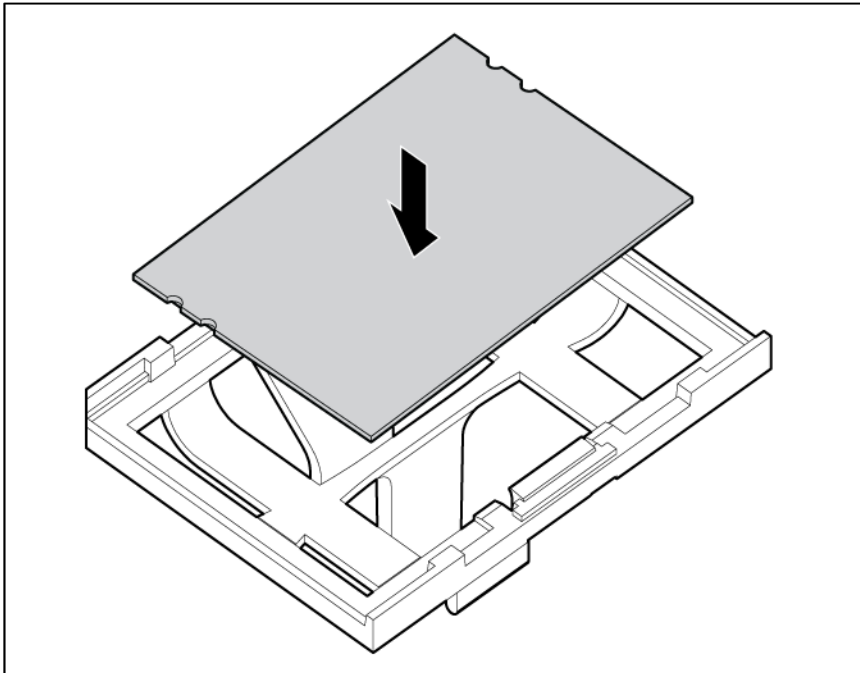

2. The processor fits one way into the socket. Use the alignment guides on the processor and socket to properly align the processor with the socket. Install the spare processor. **THE PINS ON THE SYSTEM BOARD ARE VERY FRAGILE AND EASILY DAMAGED.**

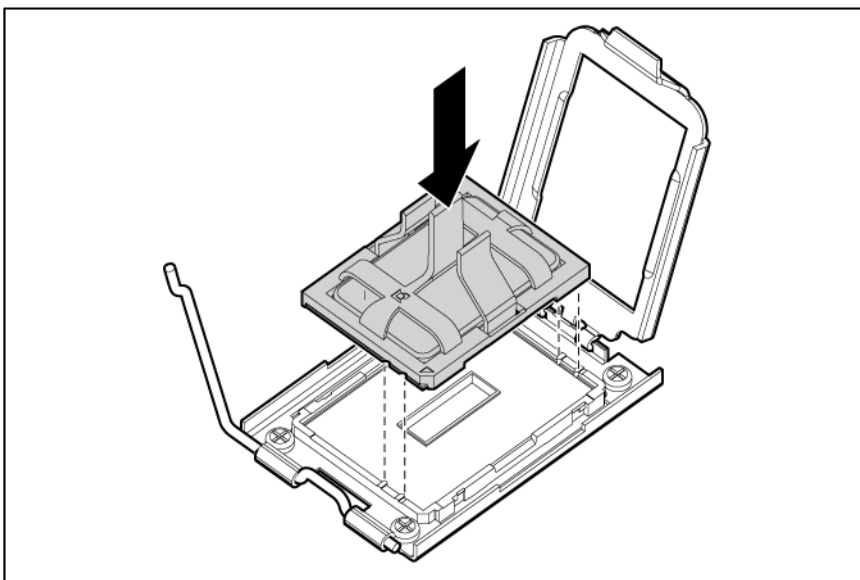



**CAUTION: THE PINS ON THE SYSTEM BOARD ARE VERY FRAGILE AND EASILY DAMAGED.** To avoid damage to the system board:

- Never install or remove a processor without using the processor installation tool.
- Do not touch the processor socket contacts.
- Do not tilt or slide the processor when lowering the processor into the socket.

3. Press the tabs on the processor tool to release the processor, and then remove the processor tool.

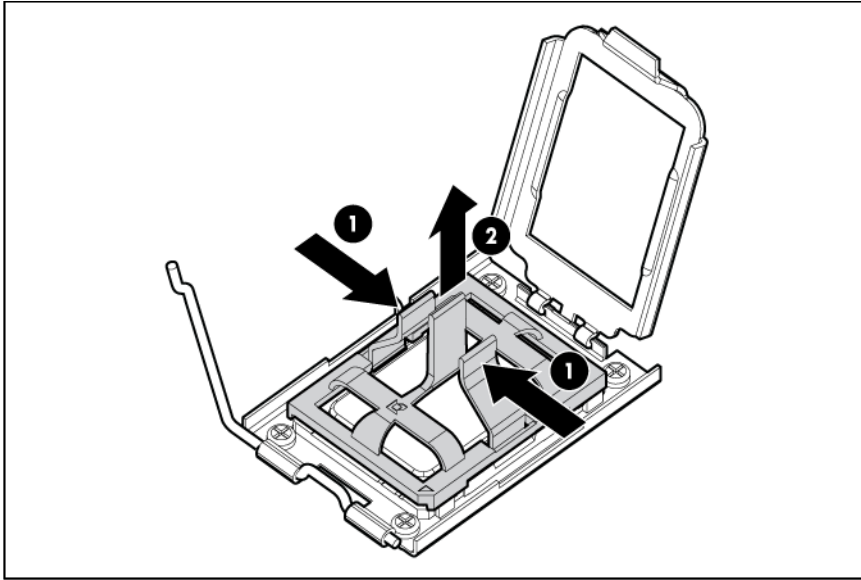

4. Close the processor socket retaining bracket and the processor locking lever.



**CAUTION:** Be sure to close the processor socket retaining bracket before closing the processor locking lever. The lever should close without resistance. Forcing the lever closed can damage the processor and socket, requiring system board replacement.

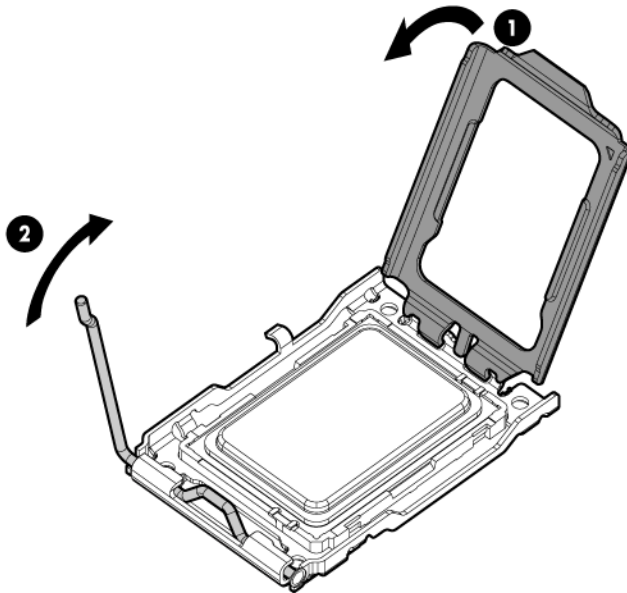

5. Clean the old thermal grease from the heatsink with the alcohol swab. Allow the alcohol to evaporate before continuing.

6. Apply all the grease to the top of the processor in the following pattern to ensure even distribution.

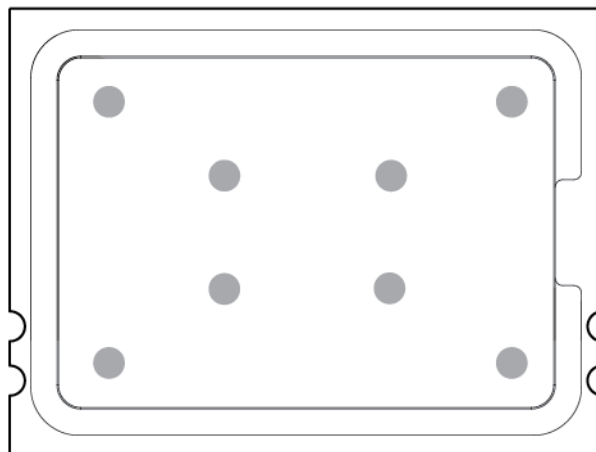

7. Install the heatsink.

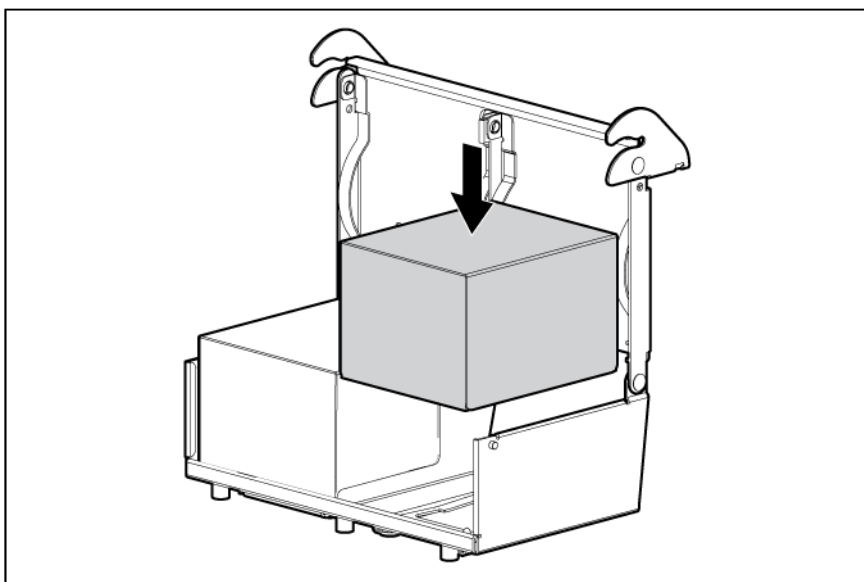

8. Close and lock the heatsink retaining latches.

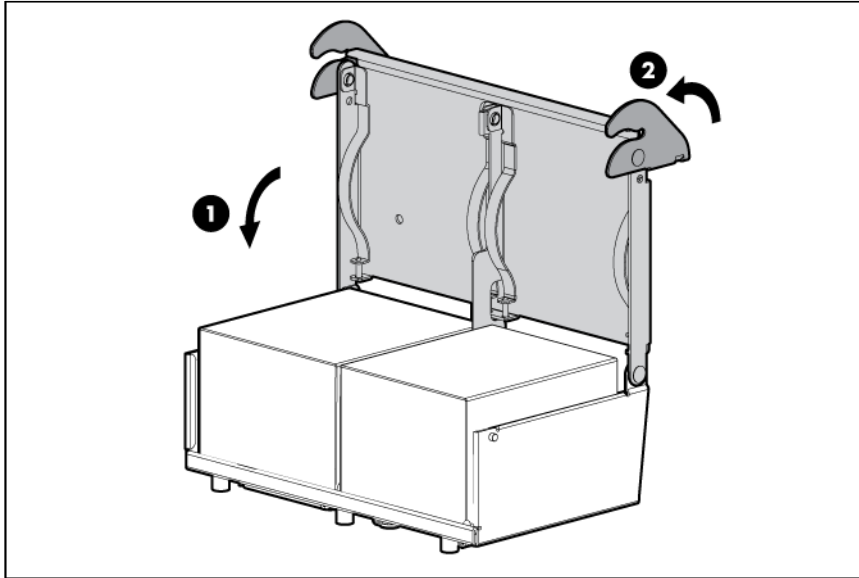

9. Install the air baffle ("[Air baffle](#)" on page 49).
10. Install the PCI riser cage ("[PCI riser cage](#)" on page 44).
11. Install the access panel ("[Access panel](#)" on page 34).
12. Install the server into the rack.
13. Power up the server.

## Memory configurations

This server supports 2 GB to 256 GB of system memory using DDR3 2-GB, 4-GB, 8-GB, and 16-GB memory modules across 24 memory sockets.

### Advanced ECC memory

Advanced ECC memory is the memory protection mode for this server. In Advanced ECC, the server does not fail because of correctable memory errors. The server provides notification if the level of correctable errors exceeds a pre-defined threshold rate.

Advanced ECC provides additional protection over standard ECC because it is possible to correct certain memory errors that would otherwise be uncorrectable and result in a server failure.

Whereas standard ECC can correct single-bit memory errors, Advanced ECC can correct single-bit memory errors and multi-bit memory errors if all failed bits are on the same DRAM device on the memory module.

### Population order

The two tables below represent the memory module population order for one processor. The population order for the other processor is identical. SR denotes Single Rank, DR denotes Dual Rank, and QR denotes Quad Rank.

All memory modules must follow the population order shown in these two tables for both processors with the following exception:

- QR memory modules must be installed only in memory sockets 2, 5, 8, and 11, while following the population order for those memory sockets.

<b>Processor memory socket</b>	<b>1</b>	<b>2</b>	<b>3</b>	<b>4</b>	<b>5</b>	<b>6</b>
Rank support per memory socket	SR/DR	SR/DR/QR	SR/DR	SR/DR	SR/DR/QR	SR/DR
<b>Population order</b>	<b>A</b>	<b>I</b>	<b>E</b>	<b>C</b>	<b>K</b>	<b>G</b>
Processor memory channel	A	A	A	B	B	B

<b>Processor memory socket</b>	<b>7</b>	<b>8</b>	<b>9</b>	<b>10</b>	<b>11</b>	<b>12</b>
Rank support per memory socket	SR/DR	SR/DR/QR	SR/DR	SR/DR	SR/DR/QR	SR/DR
<b>Population order</b>	<b>B</b>	<b>J</b>	<b>F</b>	<b>D</b>	<b>L</b>	<b>H</b>
Processor memory channel	C	C	C	D	D	D

## Population rules

When installing memory modules, observe the following population rules:

- Use only HP memory modules listed in the DL385 QuickSpecs.
- Advanced ECC is not available if x4 and x8 memory modules are mixed in channels (A and B), (C and D), or both, but standard ECC is still available. Advanced ECC is available if x4 and x8 memory modules are mixed in memory channels (A and C), (B and D), or both.
- No more than two UDIMMs may be installed per channel.
- Do not mix UDIMMs and RDIMMs within this server.

## Population guidelines

While adhering to the memory population rules ("[Population rules](#)" on page 63), performance can be improved by following the guidelines below:

- Memory modules may be installed one at a time per processor, but installing two at a time per processor provides for additional performance, installing four at a time per processor provides for better

performance, and installing equal amounts of memory for both processors provides for best performance.

- Install all memory modules of the same speed on the same processor for best performance.
- Install all memory modules of the same voltage on the same processor for best power.

## Memory bus speed

Depending on the quantity and native speed of memory modules installed, memory bus speeds can be 1333 MHz, 1066 MHz, 800 MHz, or 667 MHz. Memory bus speeds can be different for each processor.

To determine memory bus speeds, do the following:

1. Within RBSU, select the **Power Management Options** menu > **Advanced Power Management Options** menu > **Maximum Memory Bus Frequency** menu.
2. Select one of the following menu options:
  - **Auto (default)**—The memory bus speed is set to what is shown in the following table. If the native speed of the installed memory module is slower than the memory bus speed, the memory bus speed is set to the memory module native speed

Memory modules per channel	QR	SR or DR	Memory module native speed	Memory bus speed (standard-voltage memory module)	Memory bus speed (low-voltage memory module)
1	—	1*	SR 1333 MHz DR 1333 MHz DR 1066 MHz	1333 MHz	1333 MHz
1	1	—	QR 1066 MHz	1066 MHz	1066 MHz
2	—	2*	SR 1333 MHz DR 1333 MHz DR 1066 MHz	1333 MHz	1333 MHz
2	1	1	SR 1333 MHz DR 1333 MHz DR 1066 MHz QR 1066 MHz	800 MHz	800 MHz
3	—	3 SR	SR 1333 MHz	1333 MHz	1066 MHz
3	—	3 DR	DR 1333 MHz DR 1066 MHz	1066 MHz	800 MHz
3	—	3 mixed	SR 1333 MHz DR 1333 MHz DR 1066 MHz	1066 MHz	800 MHz
3	1	2	SR 1333 MHz DR 1333 MHz DR 1066 MHz QR 1066 MHz	800 MHz	667 MHz

- \*These are the only configurations supported by UDIMMs. All configurations listed in this table are supported by RDIMMs.
- LVDIMM support is dependent on the ROM version.
- This table is for reference only. It may not be updated to reflect recent changes.
- **800 MHz**—The memory bus speed is set to 800 MHz regardless of the quantity of memory modules installed, unless the table above reflects a slower memory bus speed.



---

**NOTE:** There may be more than one memory bus speed menu option.

---

## DIMMs

To remove the component:

1. Power down the server (on page 27).
2. Extend or remove the server from the rack ("Remove the server from the rack" on page 28, "Extend the server from the rack" on page 28).
3. Remove the access panel ("Access panel" on page 34).
4. Remove the PCI riser cage ("PCI riser cage" on page 44).
5. Remove the air baffle ("Air baffle" on page 49).
6. Remove the DIMM.

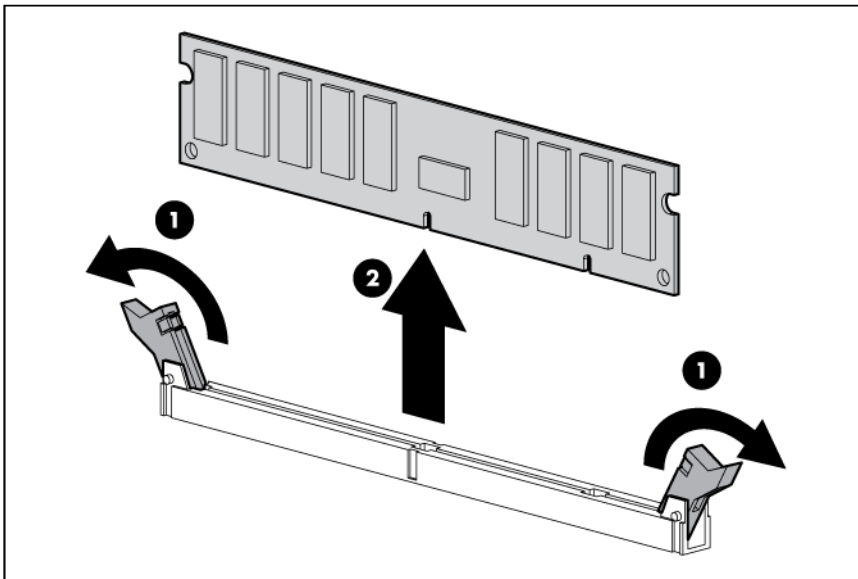

To replace the component, reverse the removal procedure.

## Battery replacement

If the server no longer automatically displays the correct date and time, you may need to replace the battery that provides power to the real-time clock.



**WARNING:** The computer contains an internal lithium manganese dioxide, a vanadium pentoxide, or an alkaline battery pack. A risk of fire and burns exists if the battery pack is not properly handled. To reduce the risk of personal injury:

- Do not attempt to recharge the battery.
  - Do not expose the battery to temperatures higher than 60°C (140°F).
  - Do not disassemble, crush, puncture, short external contacts, or dispose of in fire or water.
  - Replace only with the spare designated for this product.
-

To remove the component:

1. Power down the server (on page 27).
2. Extend or remove the server from the rack ("[Remove the server from the rack](#)" on page 28, "[Extend the server from the rack](#)" on page 28).
3. Remove the access panel ("[Access panel](#)" on page 34).
4. If any full-length expansion boards are installed, remove the full-length expansion board shipping bracket ("[Full-length expansion board shipping bracket](#)" on page 43).
5. Remove the PCI riser cage ("[PCI riser cage](#)" on page 44).
6. Remove the air baffle ("[Air baffle](#)" on page 49).
7. Remove the battery.

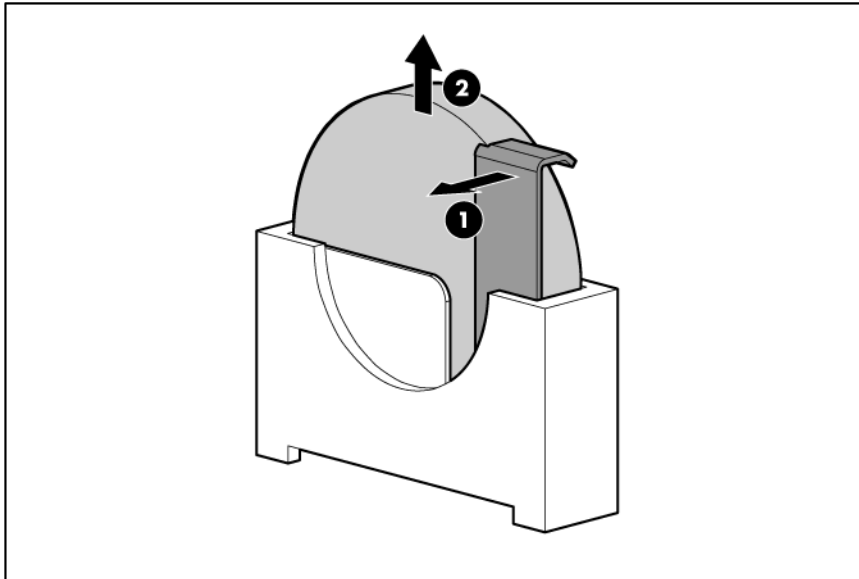

To replace the component, reverse the removal procedure.

For more information about battery replacement or proper disposal, contact an authorized reseller or an authorized service provider.

## Systems Insight Display

To remove the component:

1. Power down the server (on page 27).
2. Extend or remove the server from the rack ("[Remove the server from the rack](#)" on page 28, "[Extend the server from the rack](#)" on page 28).
3. Remove the access panel ("[Access panel](#)" on page 34).
4. Remove the PCI riser cage ("[PCI riser cage](#)" on page 44).
5. Remove the air baffle ("[Air baffle](#)" on page 49).
6. Disconnect the Systems Insight Display cable.

7. Remove the Systems Insight Display.

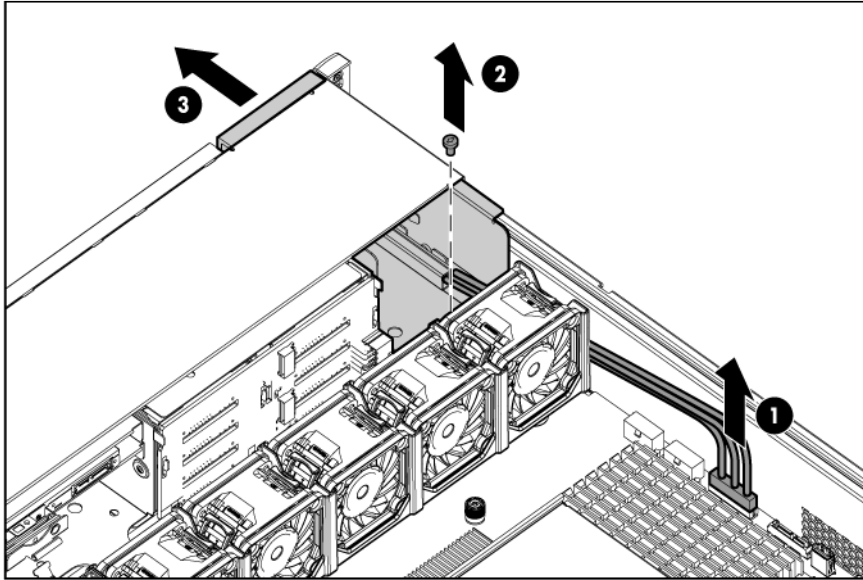

To replace the component, reverse the removal procedure.

## Front left bezel

To remove the component:

1. Power down the server (on page 27).
2. Extend or remove the server from the rack ("[Remove the server from the rack](#)" on page 28, "[Extend the server from the rack](#)" on page 28).
3. Remove the access panel ("[Access panel](#)" on page 34).
4. Remove the PCI riser cage ("[PCI riser cage](#)" on page 44).
5. Remove the air baffle ("[Air baffle](#)" on page 49).
6. Extend or remove the Systems Insight Display ("[Systems Insight Display](#)" on page 66).
7. Disconnect the System Insight Display cable from the system board.

8. Remove the three T-10 Torx screws, and then detach the front bezel.

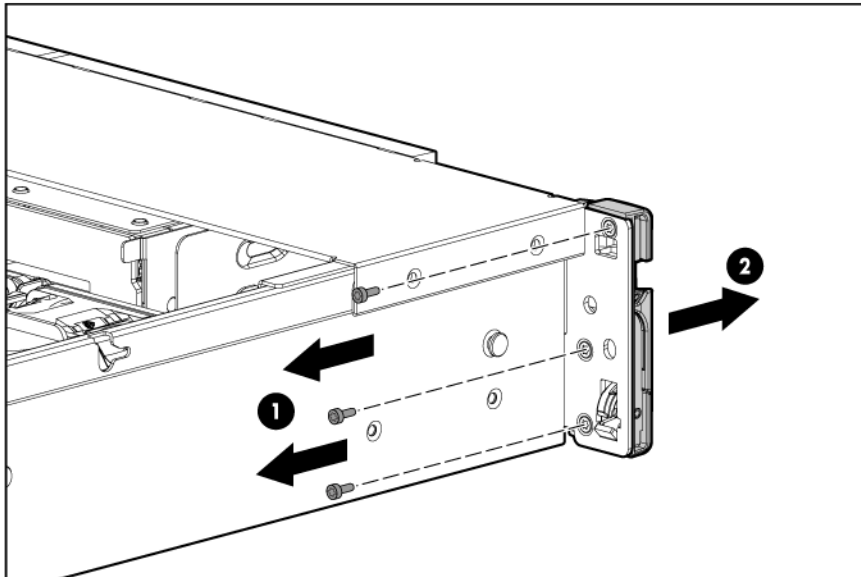

To replace the component, reverse the removal procedure.

## Power supply cage assembly

To remove the component:

1. Power down the server (on page 27).
2. Access the product rear panel (on page 29).
3. Remove all power supplies ("Hot-plug power supply" on page 32).
4. Remove the server from the rack (on page 28).
5. Remove the access panel ("Access panel" on page 34).
6. Remove the PCI riser cage ("PCI riser cage" on page 44).
7. Remove the air baffle ("Air baffle" on page 49).
8. Remove the power supply backplane ("Power supply backplane" on page 38).
9. Loosen the system board thumbscrews, and then slide the system board assembly forward.

10. Remove the power supply cage assembly.

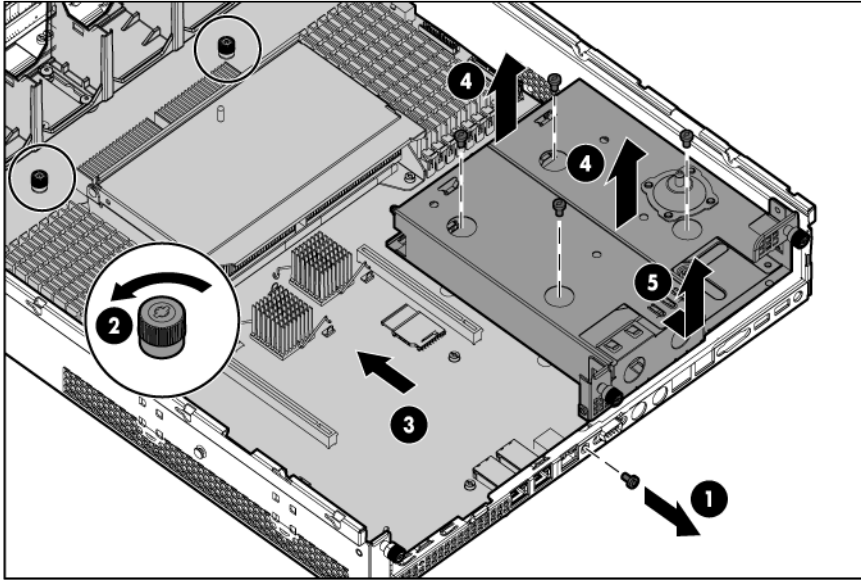

To replace the component, reverse the removal procedure.

## System board

To remove the component:

1. Power down the server (on page 27).
2. Remove all power supplies ("Hot-plug power supply" on page 32).
3. Remove the server from the rack (on page 28).
4. Remove the access panel ("Access panel" on page 34).
5. Remove the PCI riser cage ("PCI riser cage" on page 44).
6. Remove the battery pack ("Removing the battery pack" on page 50).
7. Remove the air baffle ("Air baffle" on page 49).
8. Remove the power supply backplane ("Power supply backplane" on page 38).

**CAUTION:** To prevent damage to the server or expansion boards, power down the server and remove all AC power cords before removing or installing the PCI riser cage.

9. Remove the hot-plug fans from the fan cage ("Hot-plug fan" on page 36).
10. Remove the fan cage ("Fan cage" on page 54).
11. Remove all DIMMs ("DIMMs" on page 65).

12. Open the heatsink retaining bracket, and then remove the heatsink.

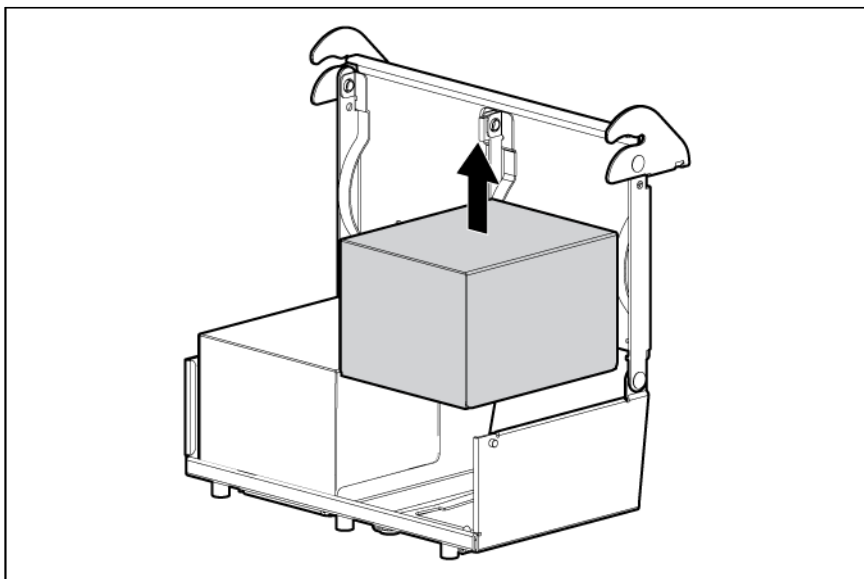

13. Open the processor socket retaining bracket and the processor locking lever.

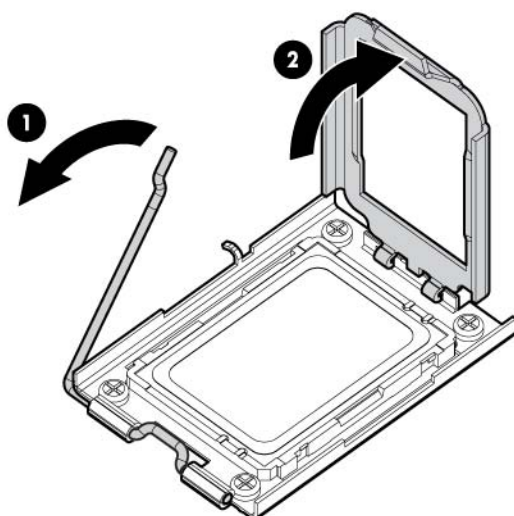

- Using the processor tool, remove the processor from the system board.

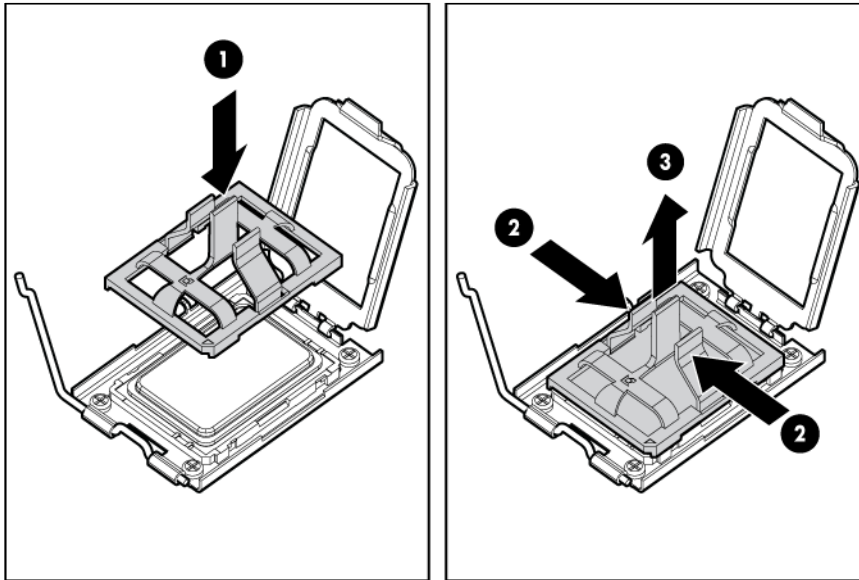

**CAUTION:** To avoid damage to the processor, do not touch the bottom of the processor, especially the contact area.

- Disconnect all cables connected to the system board.
- Remove the retaining screw at the rear of the chassis.
- Loosen the system board thumbscrews.
- Remove the power supply cage assembly ("Power supply cage assembly" on page 68).
- Remove the failed system board.

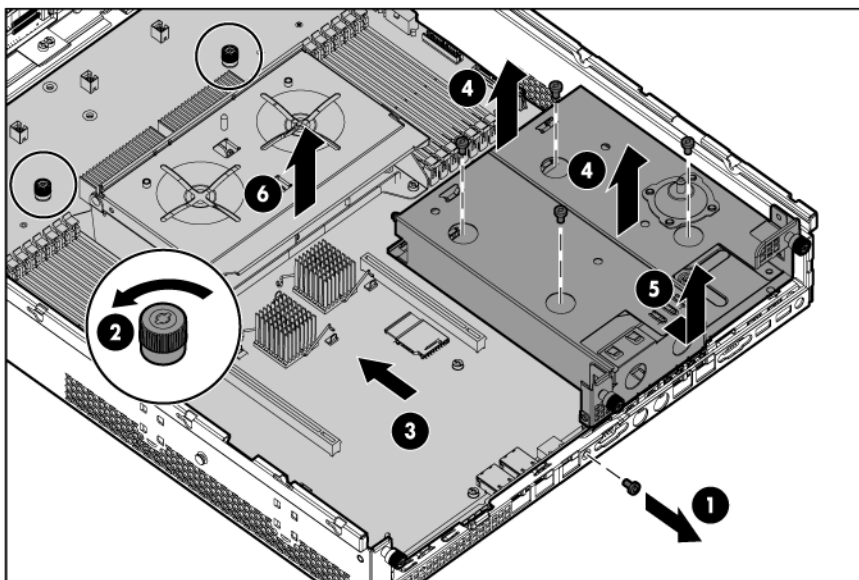

To replace the system board:

- Install the spare system board.

**CAUTION:** The pins on the processor socket are very fragile. Any damage to them may require replacing the system board.

2. Prepare the processor socket on the spare system board:
  - a. Remove the processor socket protective cover.

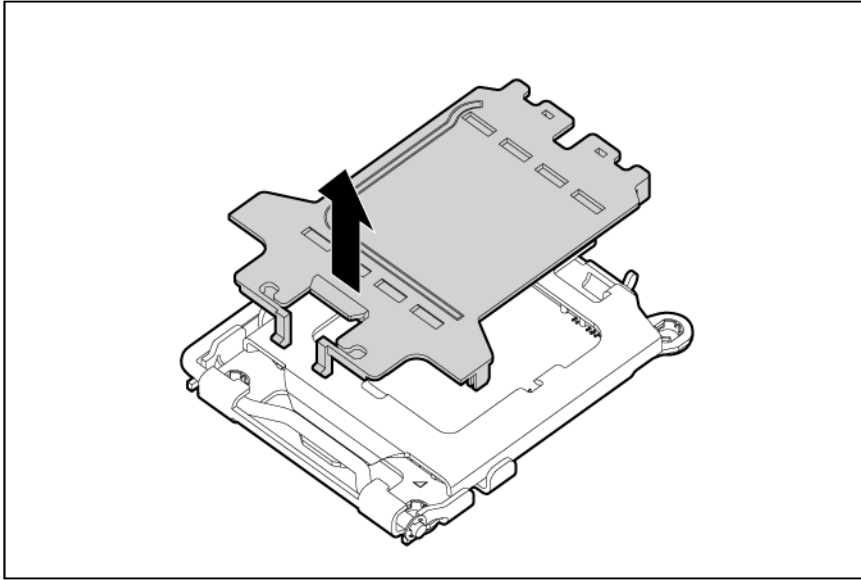

- b. Open the processor retaining latch and the processor socket retaining bracket.

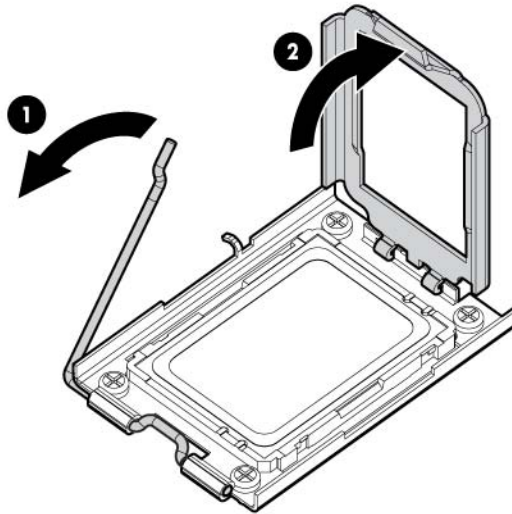

3. Install the processor socket cover onto the processor socket of the failed system board.
4. Install the processor on the spare system board.



---

**IMPORTANT:** Be sure the processor remains inside the processor installation tool.

---



5. If the processor has separated from the installation tool, carefully re-insert the processor in the tool. Handle the processor by the edges only, and do not touch the bottom of the processor, especially the contact area.

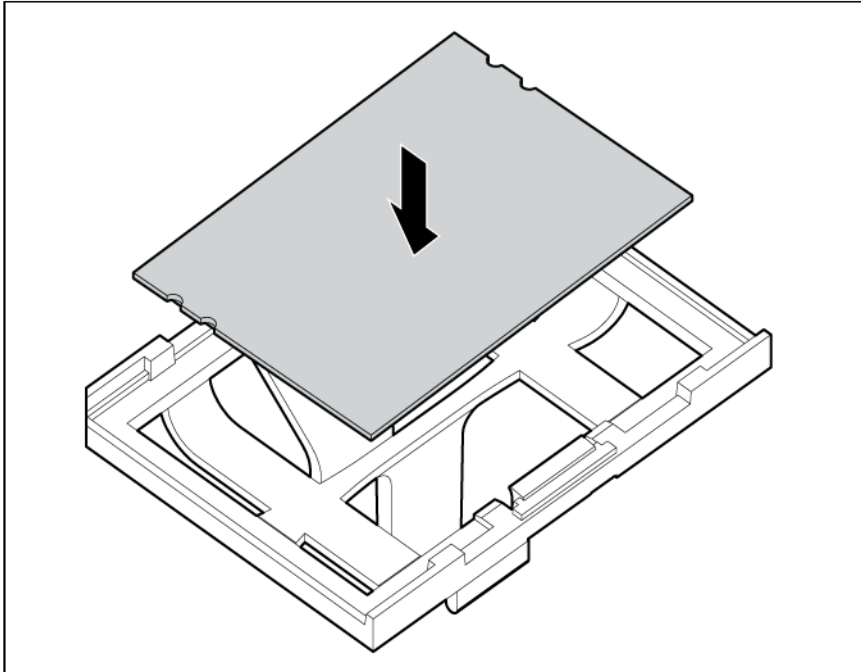

6. The processor fits one way into the socket. Use the alignment guides on the processor and socket to properly align the processor with the socket. Install the spare processor. **THE PINS ON THE SYSTEM BOARD ARE VERY FRAGILE AND EASILY DAMAGED.**

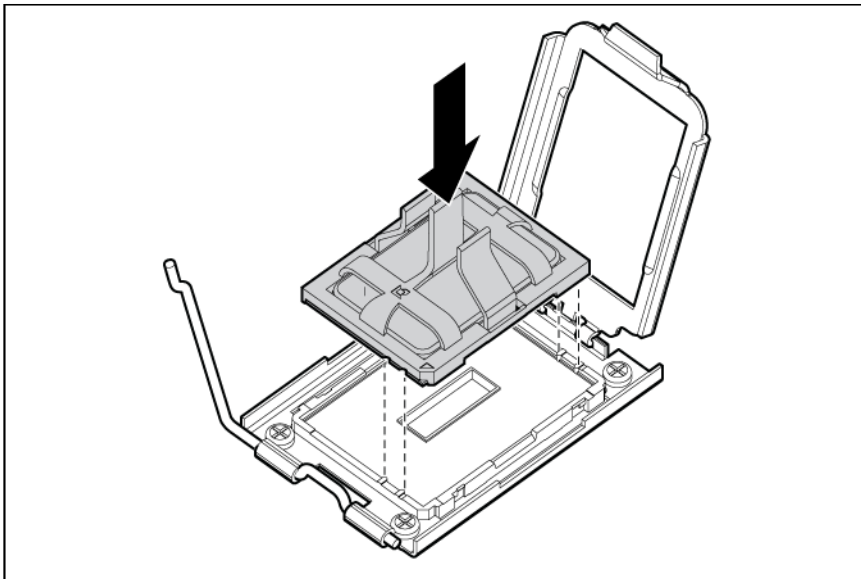

**CAUTION: THE PINS ON THE SYSTEM BOARD ARE VERY FRAGILE AND EASILY DAMAGED.** To avoid damage to the system board:

- Never install or remove a processor without using the processor installation tool.
- Do not touch the processor socket contacts.
- Do not tilt or slide the processor when lowering the processor into the socket.

7. Press the tabs on the processor tool to release the processor, and then remove the processor tool.

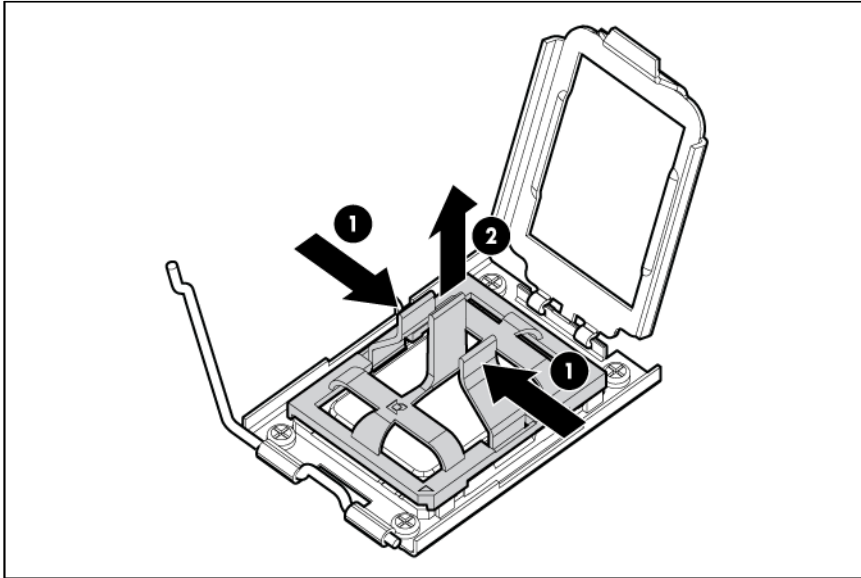

8. Close the processor socket retaining bracket and the processor locking lever.

⚠ **CAUTION:** Be sure to close the processor socket retaining bracket before closing the processor locking lever. The lever should close without resistance. Forcing the lever closed can damage the processor and socket, requiring system board replacement.

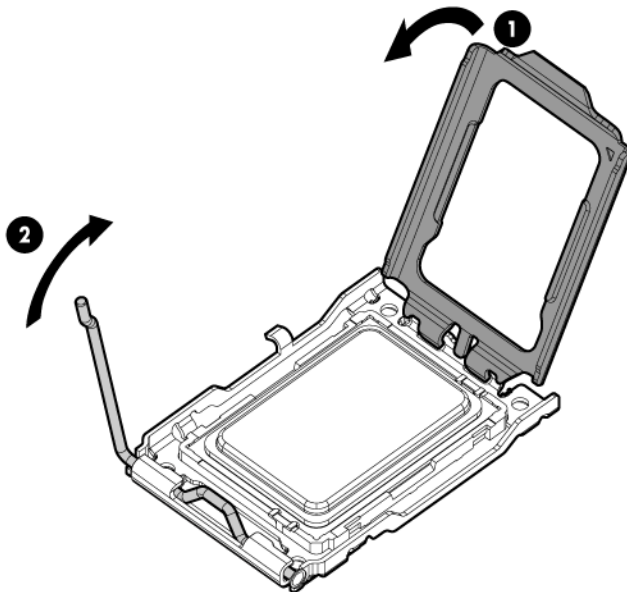

9. Clean the old thermal grease from the heatsink with the alcohol swab. Allow the alcohol to evaporate before continuing.

10. Apply all the grease to the top of the processor in the following pattern to ensure even distribution.

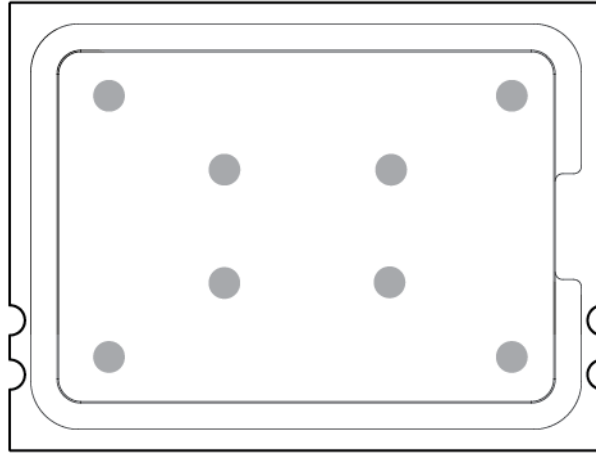

11. Install the heatsink.

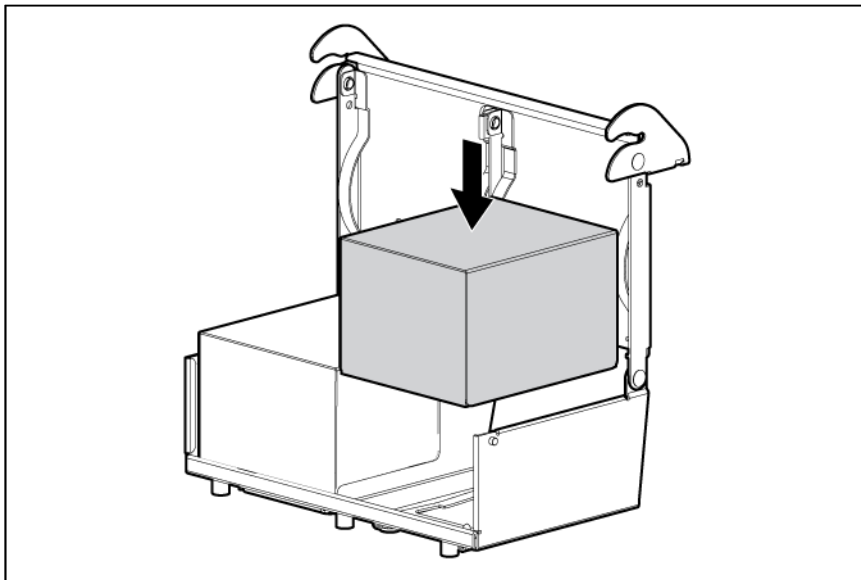

12. Install all components removed from the failed system board.
13. Install the access panel ("[Access panel](#)" on page 34).
14. Install the power supplies ("[Hot-plug power supply](#)" on page 32).
15. Power up the server.



**IMPORTANT:** Install all components with the same configuration that was used on the failed system board.

After you replace the system board, you must re-enter the server serial number and the product ID.

1. During the server startup sequence, press the **F9** key to access RBSU.
2. Select the **Advanced Options** menu.
3. Select **Service Options**.
4. Select **Serial Number**. The following warnings appear:

WARNING! WARNING! WARNING! The serial number is loaded into the system during the manufacturing process and should NOT be modified. This option should only be used by qualified service personnel. This value should always match the serial number sticker located on the chassis.

Warning: The serial number should ONLY be modified by qualified personnel. This value should always match the serial number located on the chassis.

5. Press the **Enter** key to clear the warning.
6. Enter the serial number and press the **Enter** key.
7. Select **Product ID**. The following warning appears:  
Warning: The Product ID should ONLY be modified by qualified personnel. This value should always match the Product ID on the chassis.
8. Enter the product ID and press the **Enter** key.
9. Press the **Esc** key to close the menu.
10. Press the **Esc** key to exit RBSU.
11. Press the **F10** key to confirm exiting RBSU. The server automatically reboots.

## HP Trusted Platform Module

The TPM is not a customer-removable part.



---

**CAUTION:** Any attempt to remove an installed TPM from the system board breaks or disfigures the TPM security rivet. Upon locating a broken or disfigured rivet on an installed TPM, administrators should consider the system compromised and take appropriate measures to ensure the integrity of the system data.

---

If you suspect a TPM board failure, leave the TPM installed and remove the system board. Contact an HP authorized service provider for a replacement system board and TPM board.

---

# Cabling

## SAS hard drive cabling

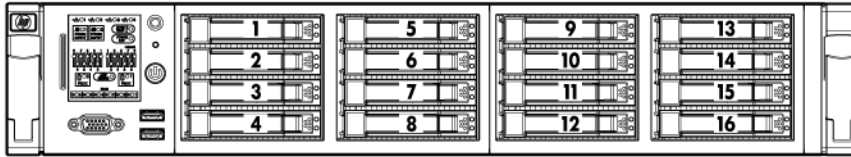
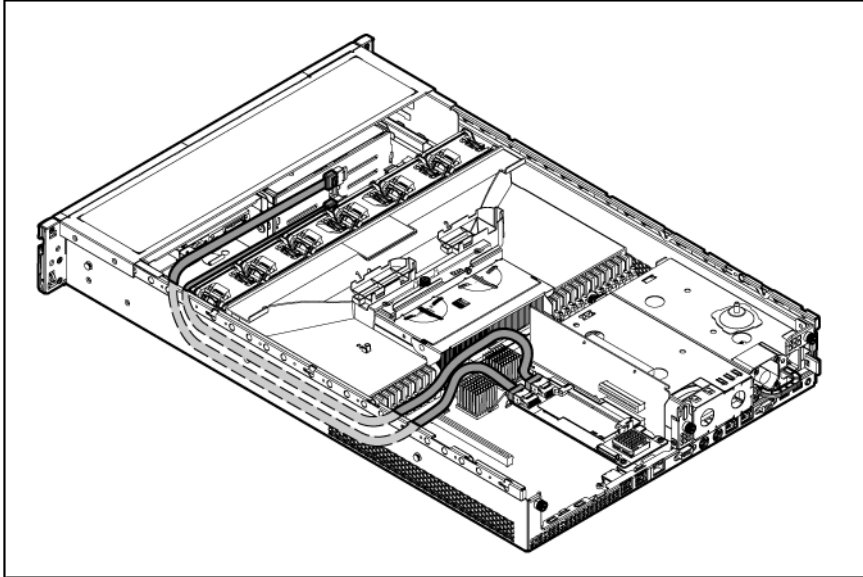

Connect the SAS power cable from the primary drive cage (drive cage containing drives 1 - 8) to the primary SAS power connector on the system board.

If a secondary drive cage (drive cage containing drives 9 - 16) is installed, connect a SAS power cable from the secondary drive cage to the secondary SAS power connector on the system board.

# BBWC battery cabling

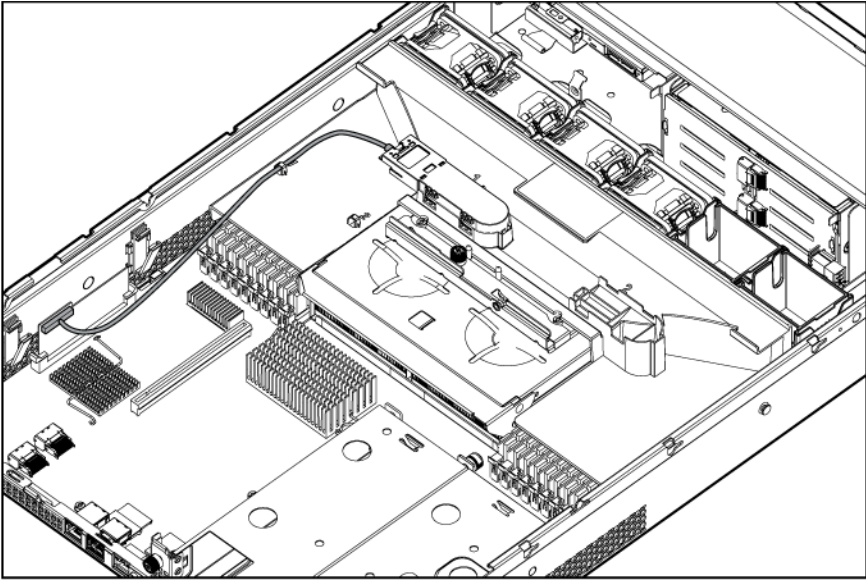

# FBWC capacitor pack cabling

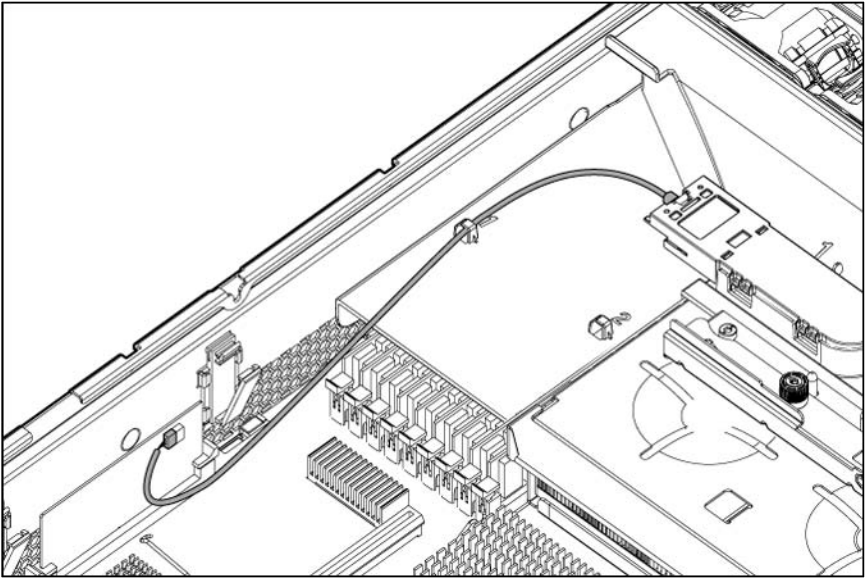

---

# Diagnostic tools

## Troubleshooting resources

The *HP ProLiant Servers Troubleshooting Guide* provides procedures for resolving common problems and comprehensive courses of action for fault isolation and identification, error message interpretation, issue resolution, and software maintenance on ProLiant servers and server blades. This guide includes problem-specific flowcharts to help you navigate complex troubleshooting processes. To view the guide, select a language:

- English ([http://www.hp.com/support/ProLiant\\_TSG\\_en](http://www.hp.com/support/ProLiant_TSG_en))
- French ([http://www.hp.com/support/ProLiant\\_TSG\\_fr](http://www.hp.com/support/ProLiant_TSG_fr))
- Italian ([http://www.hp.com/support/ProLiant\\_TSG\\_it](http://www.hp.com/support/ProLiant_TSG_it))
- Spanish ([http://www.hp.com/support/ProLiant\\_TSG\\_sp](http://www.hp.com/support/ProLiant_TSG_sp))
- German ([http://www.hp.com/support/ProLiant\\_TSG\\_gr](http://www.hp.com/support/ProLiant_TSG_gr))
- Dutch ([http://www.hp.com/support/ProLiant\\_TSG\\_nl](http://www.hp.com/support/ProLiant_TSG_nl))
- Japanese ([http://www.hp.com/support/ProLiant\\_TSG\\_jp](http://www.hp.com/support/ProLiant_TSG_jp))

## HP Insight Diagnostics

HP Insight Diagnostics is a proactive server management tool, available in both offline and online versions, that provides diagnostics and troubleshooting capabilities to assist IT administrators who verify server installations, troubleshoot problems, and perform repair validation.

HP Insight Diagnostics Offline Edition performs various in-depth system and component testing while the OS is not running. To run this utility, launch the SmartStart CD.

HP Insight Diagnostics Online Edition is a web-based application that captures system configuration and other related data needed for effective server management. Available in Microsoft® Windows® and Linux versions, the utility helps to ensure proper system operation.

For more information or to download the utility, refer to the HP website (<http://www.hp.com/servers/diags>).

## HP Insight Diagnostics survey functionality

HP Insight Diagnostics (on page 79) provides survey functionality that gathers critical hardware and software information on ProLiant servers.

This functionality supports operating systems that may not be supported by the server. For operating systems supported by the server, see the HP website (<http://www.hp.com/go/supportos>).

If a significant change occurs between data-gathering intervals, the survey function marks the previous information and overwrites the survey data files to reflect the latest changes in the configuration.

Survey functionality is installed with every SmartStart-assisted HP Insight Diagnostics installation, or it can be installed through the HP PSP.

---

**NOTE:** The current version of SmartStart provides the memory spare part numbers for the server. To download the latest version, see the HP website (<http://www.hp.com/support>).

---

## Integrated Management Log

The IML records hundreds of events and stores them in an easy-to-view form. The IML timestamps each event with 1-minute granularity.

You can view recorded events in the IML in several ways, including the following:

- From within HP SIM
- From within Survey Utility
- From within operating system-specific IML viewers
  - For NetWare: IML Viewer (does not apply to HP ProLiant DL980 Servers)
  - For Windows®: IML Viewer
  - For Linux: IML Viewer Application
- From within the iLO 3 user interface
- From within HP Insight Diagnostics (on page 79)

For more information, see the Management CD or DVD in the HP Insight Foundation suite for ProLiant.

## HP Insight Remote Support software

HP strongly recommends that you install HP Insight Remote Support software to complete the installation or upgrade of your product and to enable enhanced delivery of your HP Warranty, HP Care Pack Service, or HP contractual support agreement. HP Insight Remote Support supplements your monitoring 24 x 7 to ensure maximum system availability by providing intelligent event diagnosis, and automatic, secure submission of hardware event notifications to HP, which will initiate a fast and accurate resolution, based on your product's service level. Notifications may be sent to your authorized HP Channel Partner for on-site service, if configured and available in your country. The software is available in two variants:

- **HP Insight Remote Support Standard:** This software supports server and storage devices and is optimized for environments with 1–50 servers. Ideal for customers who can benefit from proactive notification but do not need proactive service delivery and integration with a management platform.
- **HP Insight Remote Support Advanced:** This software provides comprehensive remote monitoring and proactive service support for nearly all HP servers, storage, network, and SAN environments, plus selected non-HP servers that have a support obligation with HP. It is integrated with HP Systems Insight Manager. A dedicated server is recommended to host both HP Systems Insight Manager and HP Insight Remote Support Advanced.

Details for both versions are available on the HP website (<http://www.hp.com/go/insightremotesupport>).

To download the software, go to Software Depot (<http://www.software.hp.com>).

Select **Insight Remote Support** from the menu on the right.



# USB support

HP provides both standard USB 2.0 support and legacy USB 2.0 support. Standard support is provided by the OS through the appropriate USB device drivers. Before the OS loads, HP provides support for USB devices through legacy USB support, which is enabled by default in the system ROM.

Legacy USB support provides USB functionality in environments where USB support is not available normally. Specifically, HP provides legacy USB functionality for the following:

- POST
- RBSU
- Diagnostics
- DOS
- Operating environments which do not provide native USB support

# Component identification

## Front panel components

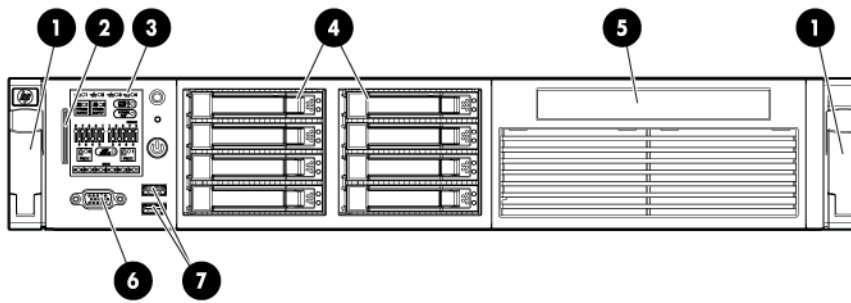

Item	Description
1	Quick release levers (2)
2	Serial number label
3	Systems Insight Display
4	Hard drive bays
5	SATA optical drive bay
6	Video connector
7	USB connectors (2)

## Front panel LEDs and buttons

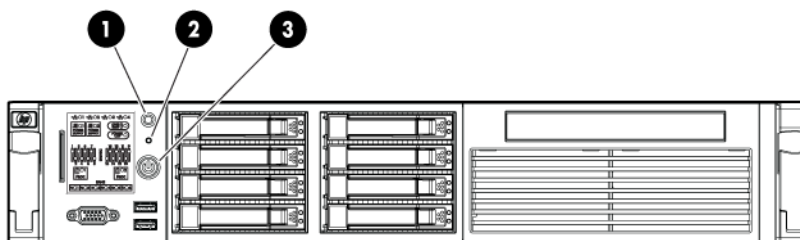

Item	Description	Status
1	UID LED button	Blue = Activated Flashing blue = System being remotely managed Off = Deactivated

Item	Description	Status
2	Health LED	Green = Normal Flashing amber = System degraded. To identify a component in a degraded state, see "Systems Insight Display LEDs (on page 88)." Flashing red = System critical. To identify a component in a critical state, see "Systems Insight Display LEDs (on page 88)."
3	Power On/Standby button and system power LED	Green = System on Flashing green = Waiting for power due to group power capping Amber = System shut down, but power still applied Off = Power cord not attached or power supply failure

## Rear panel components

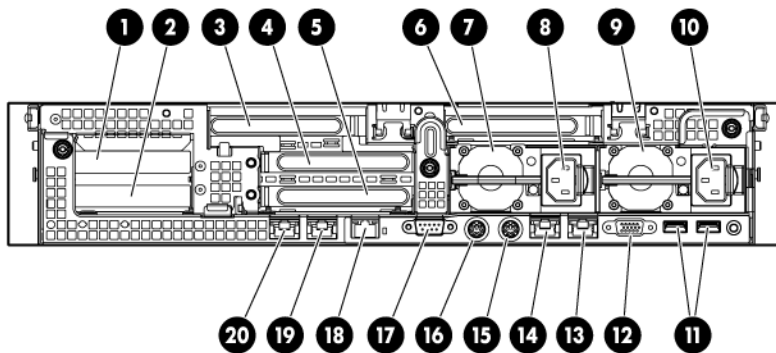

Item	Description	Color
1	PCI slot 5	—
2	PCI slot 6	—
3	PCI slot 4	—
4	PCI slot 2	—
5	PCI slot 3	—
6	PCI slot 1	—
7	Power supply 2	—
8	Power supply 2 connector	—
9	Power supply 1	—
10	Power supply 1 connector	—
11	USB connectors (2)	Black
12	Video connector	Blue
13	NIC 1 connector	—
14	NIC 2 connector	—
15	Mouse connector	Green
16	Keyboard connector	Purple
17	Serial connector	—
18	iLO 3 connector	—
19	NIC 3 connector	—
20	NIC 4 connector	—

# Rear panel LEDs and buttons

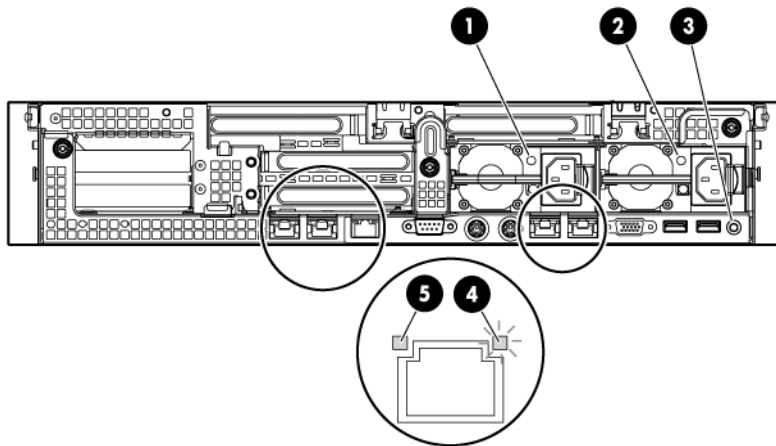

Item	Description	Status
1	Power supply 2 power LED	Green = Normal Off = System is off or power supply has failed.
2	Power supply 1 power LED	Green = Normal Off = System is off or power supply has failed.
3	UID LED button	Blue = Activated Flashing blue = System being remotely managed Off = Deactivated
4	NIC and iLO 3 activity LED	Green = Network activity Flashing green = Network activity Off = No network activity
5	NIC and iLO 3 link LED	Green = Network link Off = No network link

# System board components

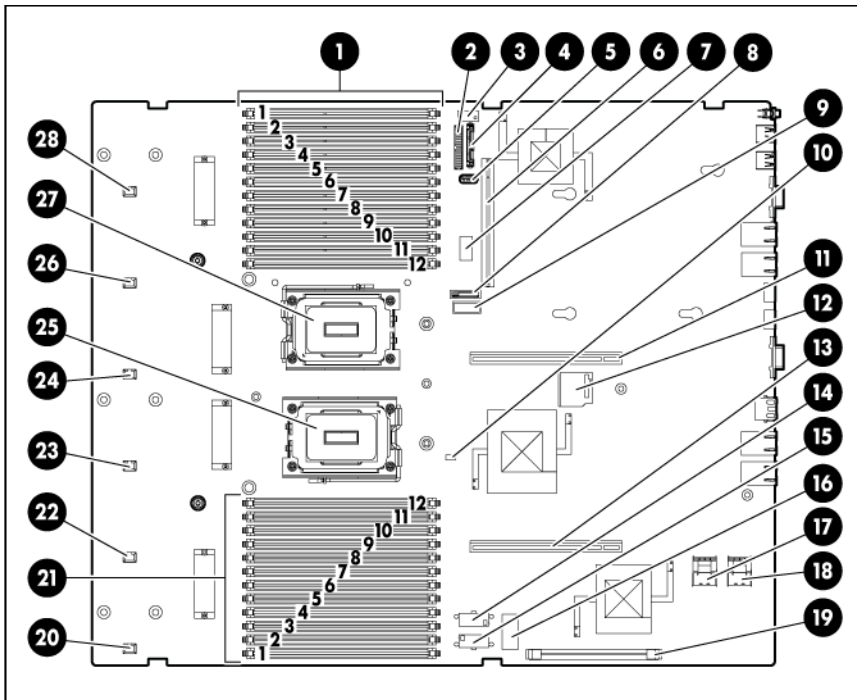

Item	Description
1	Processor 2 memory sockets
2	Front I/O connector
3	USB tape connector*
4	SATA optical drive connector
5	USB connector
6	Power supply backplane connector
7	System maintenance switch
8	System battery connector
9	TPM connector
10	NMI jumper
11	Primary riser connector
12	SD card connector
13	Secondary riser connector
14	Secondary SAS power connector
15	Primary SAS power connector
16	Diagnostics LEDs
17	Primary SAS data connector
18	Secondary SAS data connector
19	SAS cache connector
20	Fan 1 connector
21	Processor 1 memory sockets
22	Fan 2 connector
23	Fan 3 connector

Item	Description
24	Fan 4 connector
25	Processor 1 socket
26	Fan 5 connector
27	Processor 2 socket
28	Fan 6 connector

\*Connect the USB tape power connector to the secondary SAS power connector.

## System board switches

### System maintenance switch

Position	Default	Function
S1	Off	Off = iLO 3 security is enabled. On = iLO 3 security is disabled.
S2	Off	Off = System configuration can be changed. On = System configuration is locked.
S3	Off	Reserved
S4	Off	Reserved
S5	Off	Off = Power-on password is enabled. On = Power-on password is disabled.
S6	Off	Off = No function On = ROM reads system configuration as invalid.

When the system maintenance switch position 6 is set to the On position, the system is prepared to erase all system configuration settings from both CMOS and NVRAM.



**CAUTION:** Clearing CMOS and/or NVRAM deletes configuration information. There is an RBSU setting that erases default settings and fixed disk partitions, which causes a loss of data.

### Diagnostic LEDs

Position	Position	Function
S7	S8	Diagnostic LEDs
Off	Off	Port 85
Off	On	Port 84
On	Off	iLO 3

## NMI functionality

An NMI crash dump enables administrators to create crash dump files when a system is hung and not responding to traditional debug mechanisms.

Crash dump log analysis is an essential part of diagnosing reliability problems, such as hangs in operating systems, device drivers, and applications. Many crashes freeze a system, and the only available action for administrators is to cycle the system power. Resetting the system erases any information that could support problem analysis, but the NMI feature preserves that information by performing a memory dump before a hard reset.

To force the OS to invoke the NMI handler and generate a crash dump log, the administrator can do either of the following:

- Short the NMI jumper pins
- Use the iLO Virtual NMI feature

For more information, see the whitepaper on the HP website

(<http://h20000.www2.hp.com/bc/docs/support/SupportManual/c00797875/c00797875.pdf>).

## DIMM slots

DIMM slots are identified by the numbers 1 through 12.

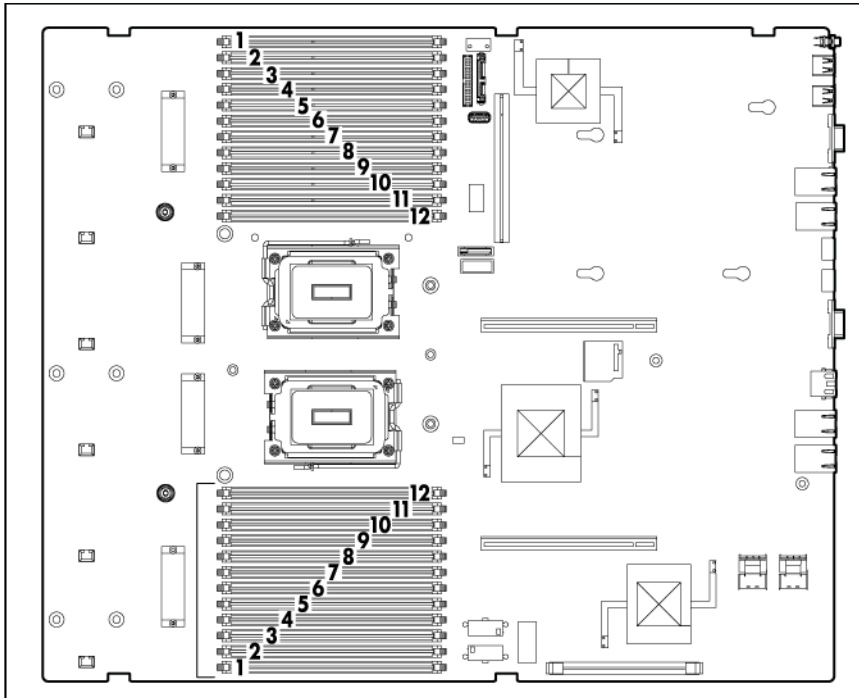

# Systems Insight Display LEDs

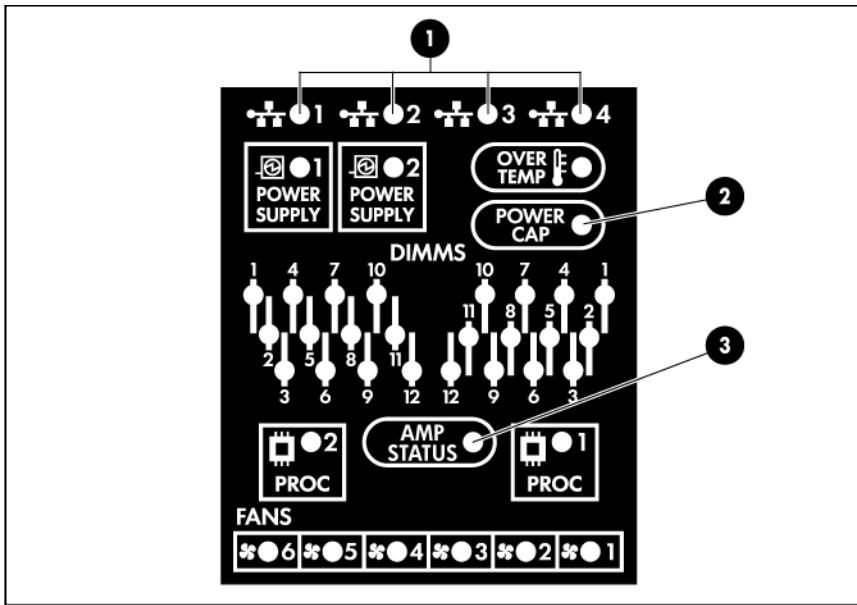

Item	Description	Status
1	NIC LEDs	Off = No link to network Flashing green = Network link and activity Green = Network link
2	Power Cap LED	Off = Server in standby Flashing amber = Power cap exceeded Green = Power cap configured
3	AMP Status LED	Off = Not enabled Green = Configured and running Amber = Failure has occurred. Flashing amber = Memory configuration is not valid.
--	All other LEDs	Off = Normal Amber = Failure

## Systems Insight Display LEDs and health LED combinations

When the health LED on the front panel illuminates either amber or red, the server is experiencing a health event. Combinations of illuminated system LEDs and the health LED indicate system status.

Systems Insight Display LED and color	Health LED color	Status
Processor (amber)	Red	One or more of the following conditions may exist: <ul style="list-style-type: none"> <li>• Processor in socket X has failed.</li> <li>• Processor X is not installed in the socket.</li> <li>• Processor X is unsupported.</li> <li>• ROM detects a failed processor during POST.</li> </ul>
	Amber	Processor in socket X is in a pre-failure condition.



Systems Insight Display LED and color	Health LED color	Status
DIMM (amber)	Red	DIMM in slot X has failed.
	Amber	DIMM in slot X is in a pre-failure condition.
DIMM (amber)	Red	One or more DIMMs have failed. Test each bank of DIMMs by removing all other DIMMs. Isolate the failed DIMM by replacing each DIMM in a bank with a known working DIMM.
Overtemperature (amber)	Amber	The Health Driver has detected a cautionary temperature level.
	Red	The server has detected a hardware critical temperature level.
Fan (amber)	Amber	One fan is failed or removed.
	Red	Two or more fans have failed or are missing.
Power supply (amber)	Red	Only one power supply is installed and is in standby. <ul style="list-style-type: none"> <li>• Power supply fault</li> <li>• System board fault</li> </ul>
Power supply (amber)	Amber	Redundant power supply is installed and only one power supply is functional. <ul style="list-style-type: none"> <li>• AC power cord not plugged into redundant power supply</li> <li>• Redundant power supply fault</li> </ul>
Power supply (amber)	Amber	Power supply mismatch at POST or power supply mismatch through hot add

## Hard drive numbering

- SFF device bay numbering

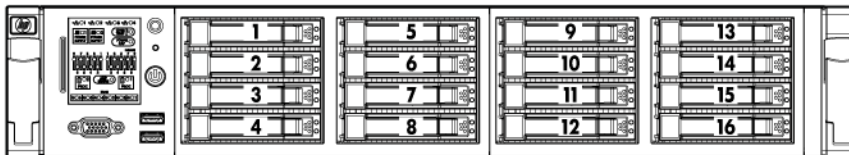

- LFF device bay numbering

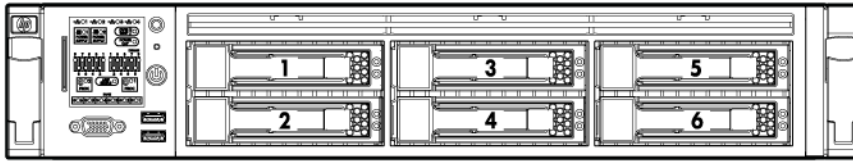

## SAS and SATA hard drive LEDs

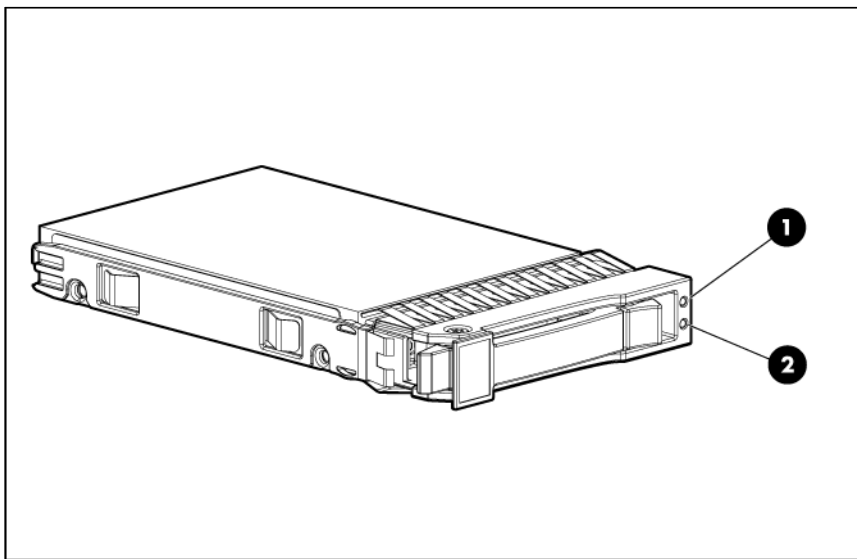

Item	Description
1	Fault/UID LED (amber/blue)
2	Online LED (green)

## SAS and SATA hard drive LED combinations

Online/activity LED (green)	Fault/UID LED (amber/blue)	Interpretation
On, off, or flashing	Alternating amber and blue	The drive has failed, or a predictive failure alert has been received for this drive; it also has been selected by a management application.
On, off, or flashing	Steadily blue	The drive is operating normally, and it has been selected by a management application.
On	Amber, flashing regularly (1 Hz)	A predictive failure alert has been received for this drive. Replace the drive as soon as possible.
On	Off	The drive is online, but it is not active currently.

Online/activity LED (green)	Fault/UID LED (amber/blue)	Interpretation
Flashing regularly (1 Hz)	Amber, flashing regularly (1 Hz)	<b>Do not remove the drive. Removing a drive may terminate the current operation and cause data loss.</b> The drive is part of an array that is undergoing capacity expansion or stripe migration, but a predictive failure alert has been received for this drive. To minimize the risk of data loss, do not replace the drive until the expansion or migration is complete.
Flashing regularly (1 Hz)	Off	<b>Do not remove the drive. Removing a drive may terminate the current operation and cause data loss.</b> The drive is rebuilding, erasing, or it is part of an array that is undergoing capacity expansion or stripe migration.
Flashing irregularly	Amber, flashing regularly (1 Hz)	The drive is active, but a predictive failure alert has been received for this drive. Replace the drive as soon as possible.
Flashing irregularly	Off	The drive is active, and it is operating normally.
Off	Steadily amber	A critical fault condition has been identified for this drive, and the controller has placed it offline. Replace the drive as soon as possible.
Off	Amber, flashing regularly (1 Hz)	A predictive failure alert has been received for this drive. Replace the drive as soon as possible.
Off	Off	The drive is offline, a spare, or not configured as part of an array.

## PCI riser cage LEDs



**CAUTION:** To prevent damage to the server or expansion boards, power down the server and remove all AC power cords before removing or installing the PCI riser cage.

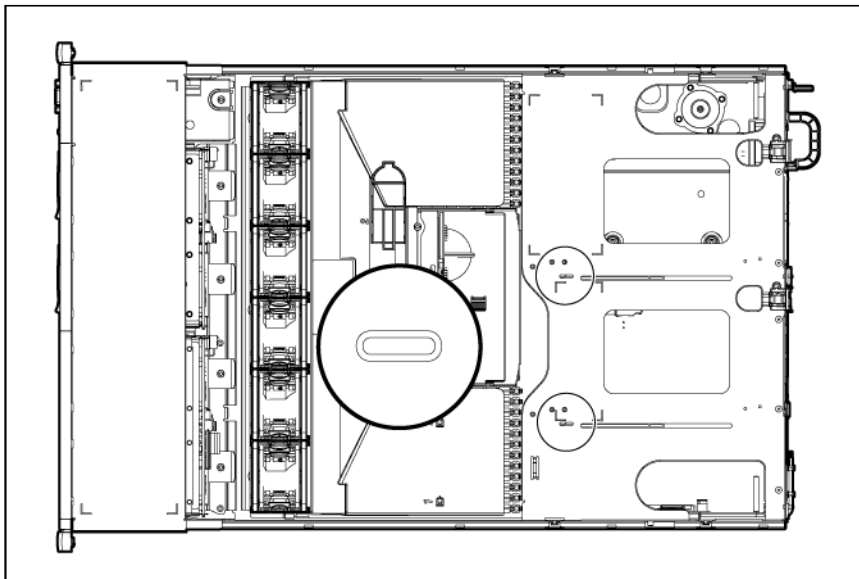

Status
On = AC power is connected.
Off = AC power is disconnected.
Missing = Riser is not installed and power might be connected.

# Non-hot-plug PCI riser board slot definitions

Secondary (slot - form factor)	Primary (slot - form factor)	PCIe2 riser slot description	PCIe2 riser slot description	PCIe2 x16 riser slot description	PCIe2/PCI-X riser slot description
4 - FL/FH	1 - FL/FH	PCIe2 x16 (8,4,2,1)	PCIe2 x16 (8,4,2,1)	PCIe2 x16 (16,8,4,2,1)	PCI-X 64 bit/100 MHz
5 - LP	2 - HL/FH	PCIe2 x8 (4,2,1)	PCIe2x16 (8,4,2,1)	—	PCI-X 64 bit/100 MHz)
6 - LP	3 - HL/FH	PCIe2 x8 (4,2,1)	—	—	PCIe2 x8 (8,4,2,1)

Notes:

- "Primary" denotes the risers are installed in the primary riser connector.
- "Secondary" denotes the risers are installed in the secondary riser connector.
- Installing the risers listed in the table above in either the primary or secondary riser connectors determines the form factor of the PCI cards supported by those risers.
- FL/FH denotes full-length, full-height. HL/FH denotes half-length, full-height. LP denotes low profile.
- The PCIe2 x16 riser supports a maximum power of 225W with an HP power cable. This cable must be used for PCIe card wattages greater than 75W.

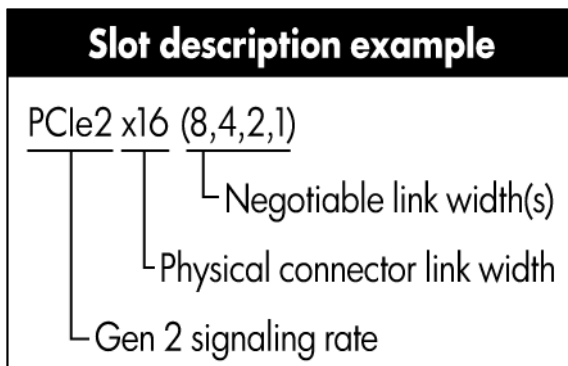

# Battery pack LEDs

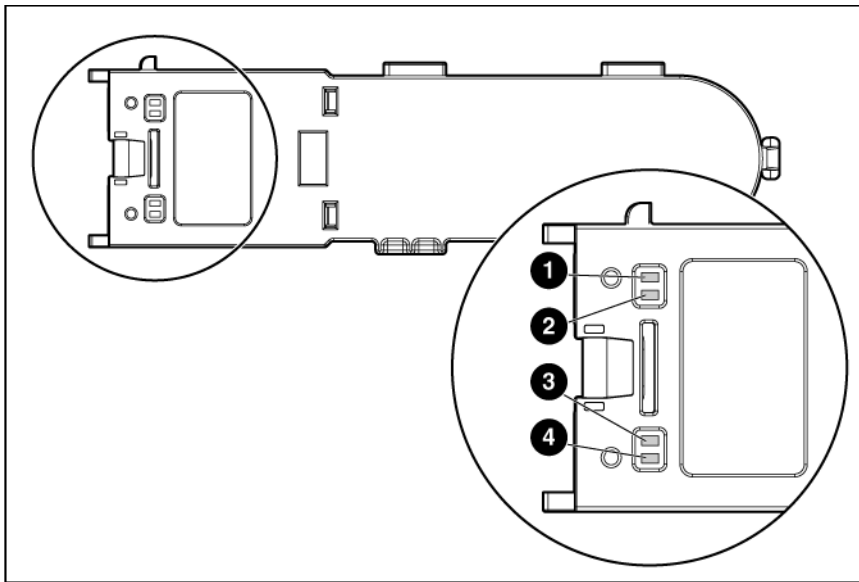

Item ID	Color	Description
1	Green	System Power LED. This LED glows steadily when the system is powered up and 12 V system power is available. This power supply is used to maintain the battery charge and provide supplementary power to the cache microcontroller.
2	Green	Auxiliary Power LED. This LED glows steadily when 3.3V auxiliary voltage is detected. The auxiliary voltage is used to preserve BBWC data and is available any time that the system power cords are connected to a power supply.
3	Amber	Battery Health LED. To interpret the illumination patterns of this LED, see the following table.
4	Green	BBWC Status LED. To interpret the illumination patterns of this LED, see the following table.

LED3 pattern	LED4 pattern	Interpretation
—	One blink every two seconds	The system is powered down, and the cache contains data that has not yet been written to the drives. Restore system power as soon as possible to prevent data loss. Data preservation time is extended any time that 3.3 V auxiliary power is available, as indicated by LED 2. In the absence of auxiliary power, battery power alone preserves the data. A fully-charged battery can normally preserve data for at least two days. The battery lifetime also depends on the cache module size. For further information, refer to the controller QuickSpecs on the HP website ( <a href="http://www.hp.com">http://www.hp.com</a> ).
—	Double blink, then pause	The cache microcontroller is waiting for the host controller to communicate.

LED3 pattern	LED4 pattern	Interpretation
—	One blink per second	The battery pack is below the minimum charge level and is being charged. Features that require a battery (such as write cache, capacity expansion, stripe size migration, and RAID migration) are temporarily unavailable until charging is complete. The recharge process takes between 15 minutes and two hours, depending on the initial capacity of the battery.
—	Steady glow	The battery pack is fully charged, and posted write data is stored in the cache.
—	Off	The battery pack is fully charged, and there is no posted write data in the cache.
One blink per second	One blink per second	An alternating green and amber blink pattern indicates that the cache microcontroller is executing from within its boot loader and receiving new flash code from the host controller.
Steady glow	—	There is a short circuit across the battery terminals or within the battery pack. BBWC features are disabled until the battery pack is replaced. The life expectancy of a battery pack is typically more than three years.
One blink per second	—	There is an open circuit across the battery terminals or within the battery pack. BBWC features are disabled until the battery pack is replaced. The life expectancy of a battery pack is typically more than three years.

## FBWC module LEDs

The FBWC module has two single-color LEDs (green and amber). The LEDs are duplicated on the reverse side of the cache module to facilitate status viewing.

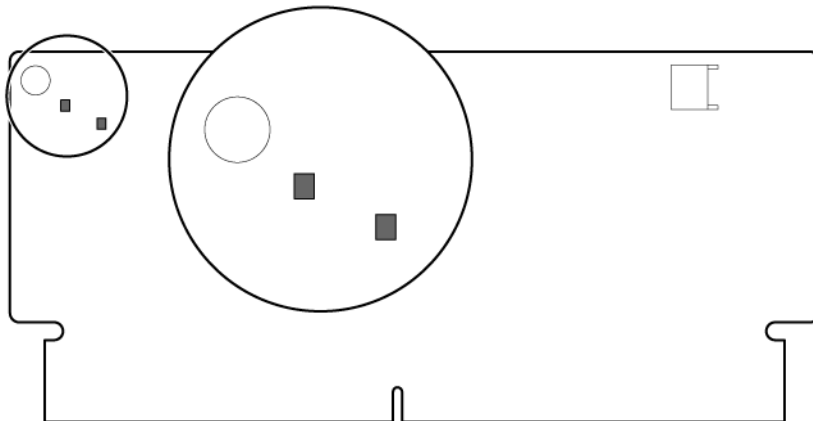

Green LED	Amber LED	Interpretation
Off	On	A backup is in progress.
Flashing (1 Hz)	On	A restore is in progress.
Flashing (1 Hz)	Off	The capacitor pack is charging.
On	Off	The capacitor pack has completed charging.

Green LED	Amber LED	Interpretation
Flashing (2 Hz) Alternating with amber LED	Flashing (2 Hz) Alternating with green LED	One of the following conditions exists: <ul style="list-style-type: none"> <li>The charging process has timed out.</li> <li>The capacitor pack is not connected.</li> </ul>
On	On	The flash code image failed to load.
Off	Off	The flash code is corrupt.

## Hot-plug fans

△ **CAUTION:** To avoid damage to server components, fan blanks must be installed in fan bays 5 and 6 in a single-processor configuration.

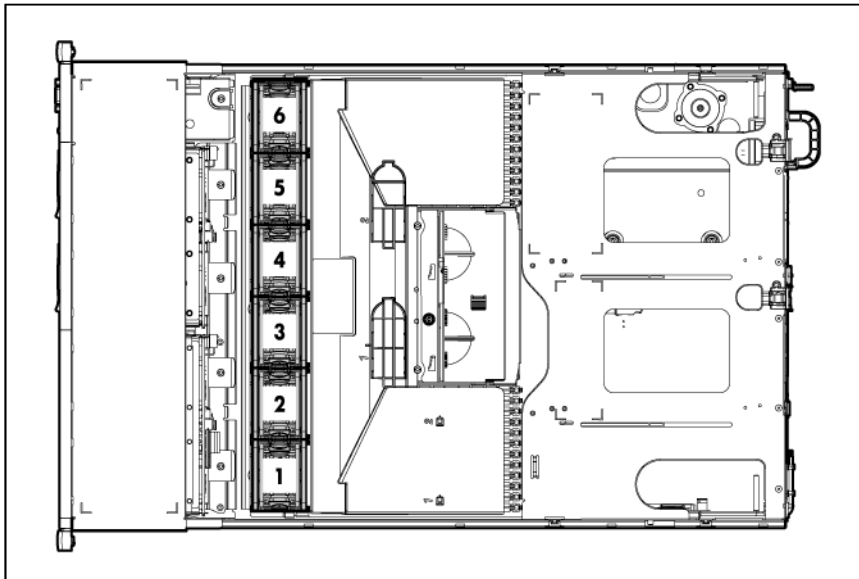

# Specifications

## Environmental specifications

Specification	Value
<b>Temperature range*</b>	
Operating	10°C to 35°C (50°F to 95°F)
Shipping	-30°C to 50°C (-22°F to 122°F)
Storage	-30°C to 60°C (-22°F to 140°F)
Maximum wet bulb temperature	28°C (82.4°F)
<b>Relative humidity (noncondensing)**</b>	
Operating	10% to 90%
Non-operating	5% to 95%

\* All temperature ratings shown are for sea level. An altitude derating of 1°C per 300 m (1.8°F per 1,000 ft) to 3048 m (10,000 ft) is applicable. No direct sunlight allowed.

\*\* Storage maximum humidity of 95% is based on a maximum temperature of 45°C (113°F). Altitude maximum for storage corresponds to a pressure minimum of 70 KPa.

## Server specifications

Specification	Value
Height	8.85 cm (3.45 in)
Depth	69.20 cm (27.25 in)
Width	44.54 cm (17.54 in)
Weight (maximum)	27.27 kg (60.12 lb)
Weight (no drives installed)	21.36 kg (47.10 lb)
<b>Input requirements*</b>	
Rated input voltage	100 to 132 VAC 200 to 240 VAC
Rated input frequency	50 Hz to 60 Hz
Rated input current	8 A at 100 VAC 3.9 A at 200 VAC
Rated input power	785 W at 100V AC input 765 W at 200V AC input
BTUs per hour	2677 at 100V to 120V AC input 2609 at 200V to 240V AC input
<b>Power supply output</b>	
Rated steady-state power	For more information, see "Power supply specifications (on page 97)."



Rated peak power	For more information, see "Power supply specifications (on page 97)."
------------------	---

\*The system input requirements are based on measurements using hardware available at the publication of this document. For updated information, see the HP website (<http://www.hp.com/go/proliant-energy-efficient>).

## Power supply specifications

The following specifications provide information on the parameters of the power supplies as they were designed. For more information on configuring power for a specific server, see the HP website (<http://www.hp.com/go/proliant-energy-efficient>).

Depending on installed options, the server is configured with one of the following power supplies:

- HP ProLiant 460 W Power Supply

Specification	Value
<b>Input requirements</b>	
Rated input voltage	100V to 120V AC 200V to 240V AC
Rated input frequency	50Hz to 60Hz
Rated input current	5.5A at 100V AC 2.6A at 200V AC
Rated input power	526 W at 100V AC input 505 W at 200V AC input
BTUs per hour	1794 at 100V AC input 1725 at 200V AC input
<b>Power supply output</b>	
Rated steady-state power	460 W at 100V to 120V AC input 460 W at 200V to 240V AC input
Rated peak power	460 W at 100V to 120V AC input 460 W at 200V to 240V AC input

- HP ProLiant 750 W Power Supply

Specification	Value
<b>Input requirements</b>	
Rated input voltage	100V to 120V AC 200V to 240V AC
Rated input frequency	50Hz to 60Hz
Rated input current	8.9A at 100V AC 4.3A at 200V AC
Rated input power	857 W at 100V AC input 824 W at 200V AC input
BTUs per hour	2925 at 100V AC input 2812 at 200V AC input
<b>Power supply output</b>	
Rated steady-state power	750 W at 100V to 120V AC input 750 W at 200V to 240V AC input

Rated peak power	750 W at 100V to 120V AC input 750 W at 200V to 240V AC input
------------------	--

- HP ProLiant 1200 W Power Supply

Specification	Value
<b>Input requirements</b>	
Rated input voltage	100V to 120V AC 200V to 240V AC
Rated input frequency	50 Hz to 60 Hz
Rated input current	9.3A at 100V AC 6.6A at 200V AC
Rated input power	912 W at 100V AC input 1294 W at 200V AC input
BTUs per hour	3110 at 100V AC input 4413 at 200V input
<b>Power supply output</b>	
Rated steady-state power	800 W at 100V AC input 900 W at 120V AC input 1200 W at 200V to 240V AC input
Rated peak power	800 W at 100V AC input 900 W at 120V AC input 1200 W at 200V to 240V AC input

- HP ProLiant 1200 W DC Power Supply

Specification	Value
<b>Input requirements</b>	
Rated input voltage	-36V to -72V DC -48V DC, nominal input
Rated input frequency	Not applicable
Rated input current	38A at -36V DC 19A at -72V DC 28A at -48V DC, nominal input
Rated input power	1380 W at -36V DC input 1365 W at -72V DC input 1350 W at -48V DC, nominal input
BTUs per hour	4713 at -36V DC input 4662 at -72V DC input 4610 at -48V DC, nominal input
<b>Power supply output</b>	
Rated steady-state power	1200 W
Rated peak power	1200 W

# Hot-plug power supply calculations

For hot-plug power supply specifications and calculators to determine electrical and heat loading for the server, refer to the HP Enterprise Configurator website (<http://h30099.www3.hp.com/configurator/>).

## CD-ROM drive specifications

Specification	Value
Disk formats	CD-ROM (modes 1 and 2); mixed mode (audio and data combined); CD-DA; Photo CD (single/multiple-session), CD-XA ready; CDi ready
Capacity	550 MB (mode 1, 12 cm) 640 MB (mode 2, 12 cm)
Block size	2368, 2352 bytes (mode 0) 2352, 2340, 2336, 2048 bytes (mode 1) 2352, 2340, 2336, 2048 bytes (mode 2)
<b>Dimensions</b>	
Height	12.7 mm (0.50 in)
Depth	132.08 mm (5.20 in)
Width	132.08 mm (5.20 in)
Weight	0.34 kg (0.75 lb)
<b>Data transfer rate</b>	
Sustained	150 KB/s (sustained 1X), 1500/3600 KB/s (10X to 24X)
Burst	16.6 MB/s
<b>Access times (typical)</b>	
Full stroke	300 ms
Random	140 ms
Diameter	12 cm, 8 cm (4.70 in, 3.15 in)
Thickness	1.2 mm (0.05 in)
Track pitch	1.6 $\mu\text{m}$ ( $6.3 \times 10^{-7}$ in)
Cache/buffer	128 KB
Startup time	< 10 s
Stop time	< 5 s (single); < 30 s (multisession)
<b>Laser parameters</b>	
Type	Semiconductor laser GaAs
Wave length	700 $\pm$ 25 nm
Divergence angle	53.5° $\pm$ 1.5°
Output power	0.14 mW
<b>Operating conditions</b>	
Temperature	5°C to 55°C (41°F to 131°F)
Humidity	10% to 80%

## DVD-ROM drive specifications

Specification	Value
Disk formats	DVD (single and double layer), DVD-5, DVD-9, DVD-10, DVD-R, CD-ROM Mode 1 & 2, CD-DA, CD-XA (Mode 2, Form 1 & 2), CD-I (Mode 2, Form 1 & 2), CD-I ready, CD-Bridge, CD-R, PhotoCD (single and multi-session)
Capacity	4.7 GB (DVD-5), 8.5 GB (DVD-9), 9.4 GB (DVD10), 550 Mb (Mode 1, 12 cm), 640 Mb (Mode 2, 12 cm), 180 Mb (8 cm)
Block size	2352 bytes (mode 0) 2352, 2340, 2336, 2048 bytes (mode 1) 2352, 2340, 2336, 2048 bytes (mode 2) 2048 bytes (DVD)
<b>Dimensions</b>	
Height	12.7 mm (0.50 in)
Depth	132.08 mm (5.20 in)
Width	132.08 mm (5.20 in)
Weight	0.34 kg (0.75 lb)
<b>Data transfer rate</b>	
Sustained	4463 - 10,800 KB/s (8X CAV DVD mode), 150 KB/s (sustained 1X CD-ROM), 1552 3600 KB/s (24X CAV CD-ROM)
Burst	16.6 MB/s with DMA support
<b>Access times (typical)</b>	
Full stroke	<200 ms CD <300 ms DVD
Random	<110 ms CD <180 ms DVD
Diameter	12 cm, 8 cm (4.70 in, 3.15 in)
Thickness	1.2 mm (0.05 in)
Track pitch	0.74 $\mu\text{m}$ ( $3.15 \times 10^{-7}$ in) DVD-ROM 1.6 $\mu\text{m}$ ( $6.3 \times 10^{-7}$ in) CD-ROM
Cache/buffer	128 KB
Startup time	< 15 s
Stop time	< 5 s (single); < 30 s (multisession)
<b>Laser parameters</b>	
Type	Semiconductor laser GaAs
Wave length	700 $\pm$ 25 nm
Divergence angle	53.5° $\pm$ 1.5°
Output power	0.14 mW
<b>Operating conditions</b>	
Temperature	5°C to 55°C (41°F to 131°F)
Humidity	10% to 80%

## SAS and SATA hard drive specifications

Item	36-GB SAS drive	72-GB SAS drive	60-GB SATA drive
Capacity	36,420 MB	73,408 MB	60,022 MB

<b>Item</b>	<b>36-GB SAS drive</b>	<b>72-GB SAS drive</b>	<b>60-GB SATA drive</b>
Height	15 mm	15 mm	9 mm
Interface	SAS	SAS	Serial ATA
Transfer rate	3 GB/sec	3 GB/sec	1.5 GB/sec
Rotational speed	10,000 rpm	10,000 rpm	5,400 rpm
Bytes per sector	512	512	512
Logical blocks	71,132,960	143,374,737	117,231,408
Operating temperature	10°C to 35°C (50°F to 95°F)	10°C to 35°C (50°F to 95°F)	10°C to 35°C (50°F to 95°F)

---

# Acronyms and abbreviations

## ABEND

abnormal end

## ASR

Automatic Server Recovery

## BBWC

battery-backed write cache

## DDR

double data rate

## FBWC

flash-backed write cache

## iLO 3

Integrated Lights-Out 3

## IML

Integrated Management Log

## NMI

non-maskable interrupt

## NVRAM

non-volatile memory

## ORCA

Option ROM Configuration for Arrays

## PCIe

peripheral component interconnect express

## PCI-X

peripheral component interconnect extended

## POST

Power-On Self Test

## RBSU

ROM-Based Setup Utility

## RDP

Rapid Deployment Pack

## SAS

serial attached SCSI

## SATA

serial ATA

## TPM

trusted platform module

## UID

unit identification

## USB

universal serial bus

---

# Index

## A

AC power supply 33  
access panel 35  
air baffle 28, 50

## B

battery 67, 89  
battery cabling for BBWC 80  
battery pack LEDs 97  
battery-backed write cache (BBWC) 50, 52, 97  
battery-backed write cache battery pack 50  
bezel 35, 69  
blue screen event 90  
buttons 84, 85

## C

cable management arm 30, 31  
cables 79  
cabling 79  
cabling, BBWC 80  
cache module 51  
cache module, removing 51  
cautions 27  
CD-ROM drive 104  
components 17, 21, 27, 78, 84  
components, identification 84, 90  
connectors 84  
crash dump analysis 90  
CSR (customer self repair) 6  
customer self repair (CSR) 6

## D

diagnostic tools 81  
diagnostics utility 81  
DIMMs 64, 66, 91  
drive LEDs 94  
DVD-ROM drive 105

## E

electrostatic discharge 27

environmental specifications 101  
expansion boards 48  
expansion slot covers 46  
expansion slot covers, removing 46  
expansion slots 46, 86, 87  
extending server from rack 29

## F

fan brackets 56  
fan cage 56  
fans 38  
FBWC cabling 80  
FBWC module LEDs 99  
features 84  
flash-backed write cache capacitor pack 54  
flash-backed write cache module 53  
flash-backed write cache procedures 53  
front panel components 84  
front panel LEDs 85  
full-length expansion board 49  
full-length expansion board shipping bracket 44

## H

half-length expansion board 48  
hard drive backplane 40, 42  
hard drive bays 84  
hard drive blanks 32  
hard drive LEDs 94  
hard drive numbering 93  
hard drives 32, 94, 106  
hard drives, determining status of 94  
health LEDs 85, 90, 94  
heatsink 56  
hot-plug fans 30, 99  
HP Insight Diagnostics 81, 82  
HP Insight Remote Support software 82

## I

illustrated parts catalog 17  
iLO 2 connector 86  
IML (Integrated Management Log) 82  
Insight Diagnostics 81, 82  
Integrated Management Log (IML) 82



internal health LED 92, 94

## K

keyboard connector 86

## L

LED, system power 85

LEDs 84, 94

LEDs, battery pack 97

LEDs, front panel 85

LEDs, hard drive 94

LEDs, NIC 86, 87

LEDs, power supply 86, 87, 91

LEDs, rear panel 86, 87

LEDs, troubleshooting 95

LFF drive cage 43

## M

management tools 81

mechanical components 17

memory 64

memory bus speed 65

memory configurations 63

memory dump 90

memory module population guidelines 65

memory module population order 64

memory module population rules 65

mouse connector 86

## N

NIC connectors 86

NMI jumper 90

non-hot-plug PCI riser board slot definitions 96

## O

operating system crash 90

optical drive 36

optical drive cage 37

## P

part numbers 17, 21

PCI expansion slots 86, 96

PCI riser cage 45

power cord connector 86

power LEDs, system 97

Power On button 84

power requirements 104

power supply 86, 104

power supply backplane 39

power supply blank 33

power supply cage assembly 70

power supply specifications 102

powering down 28

preparation procedures 28

processor tool 58, 71

processors 58

## R

rear panel components 86

rear panel connectors 86

rear panel LEDs 87, 91

rear panel, accessing 30

removal and replacement procedures 27

removing server from rack 30

removing the access panel 35

removing the battery pack 51

required tools 27

resetting the system 90

## S

safety considerations 27

SAS hard drive LEDs 94

serial connector 86

serial number 84

SFF drive cage 41

SID 68

specifications 101, 102

specifications, CD-ROM drive 104

specifications, DVD-ROM drive 105

specifications, environmental 101

specifications, hard drive 106

specifications, power 102

specifications, power supply 102

specifications, server 101, 104

static electricity 27

status lights, battery pack 97

switches 89, 90

system battery 67

system board 71

system board components 88

system components 17, 21, 84

system maintenance switch 89, 90

system power LED 85, 97

Systems Insight Display LEDs 91, 92

## **T**

telco racks 28, 30

tool, processor 58, 71

tools 81

TPM (Trusted Platform Module) 78

troubleshooting 81

Trusted Platform Module (TPM) 78

## **U**

UID LED 85, 87, 90

USB connectors 84, 86

USB support 83

utilities 81

## **V**

video connector 84, 86

## **W**

warnings 27