

HP ProLiant DL585 G6 Server Maintenance and Service Guide



Part Number 576360-003
September 2009 (Third Edition)

© Copyright 2009 Hewlett-Packard Development Company, L.P.

The information contained herein is subject to change without notice. The only warranties for HP products and services are set forth in the express warranty statements accompanying such products and services. Nothing herein should be construed as constituting an additional warranty. HP shall not be liable for technical or editorial errors or omissions contained herein.

Microsoft, Windows, NT, and Windows Server are U.S. registered trademarks of Microsoft Corporation. AMD and Opteron are trademarks of Advanced Micro Devices, Inc.

Intended audience

This guide is for an experienced service technician. HP assumes you are qualified in the servicing of computer equipment and trained in recognizing hazards in products with hazardous energy levels and are familiar with weight and stability precautions for rack installations.

Contents

Customer self repair	6
Parts only warranty service	6
Illustrated parts catalog	17
Mechanical components.....	17
System components	20
Removal and replacement procedures	24
Required tools.....	24
Safety considerations.....	24
Preventing electrostatic discharge	24
Server warnings and cautions	24
Preparation procedures.....	25
Power down the server	25
Extending the server from the rack	26
Remove the server from the rack	27
Removing the access panel.....	27
Removing the processor memory module	28
Power button assembly bezel.....	30
USB cable assembly	31
Video cable assembly	31
Power button cable assembly	32
Fan cage bezel.....	33
Processor memory module bezel	34
Processors	34
PPM	40
DIMMs.....	41
Processor memory module	42
SAS or SATA hard drives	43
Diskette, DVD, CD-RW drive, or blank	43
Power supply blank	44
Power supply.....	44
Hot-plug fans	45
Expansion slot covers.....	46
Expansion boards	47
SAS backplane	48
Pass-through board.....	49
Media board	49
Battery-backed write cache procedures	50
Removing the cache module	50
BBWC battery pack.....	52
Recovering data from the battery-backed write cache.....	53
System cage	54
Power supply backplane	55
System board	56
Re-entering the server serial number and product ID	57
System battery	57

Diagnostic tools	59
SmartStart software	59
SmartStart Scripting Toolkit	59
HP Insight Remote Support software	59
Option ROM Configuration for Arrays	60
HP ROM-Based Setup Utility	60
ROMPaq utility	61
System Online ROM flash component utility	61
Integrated Management Log	61
Integrated Lights-Out 2 technology	62
Automatic Server Recovery	62
HP Systems Insight Manager	62
HP Insight Diagnostics	63
USB support	63
Troubleshooting the system using port 85 codes	63
Processor-related port 85 codes	64
Memory-related port 85 codes	64
Expansion board-related port 85 codes	65
Miscellaneous port 85 codes	66
Component identification	67
Front panel components	67
Front panel LEDs and buttons	68
Processor memory module components	69
DIMM slot identification	70
SAS and SATA hard drive LEDs	70
SAS and SATA hard drive LED combinations	71
Rear panel components	72
Rear panel LEDs and buttons	73
Hot-plug power supply LEDs	73
Internal components	74
System maintenance switch (SW3)	75
Media board components	76
Boot device selector switch (SW1)	77
Systems Insight Display LEDs	77
Battery pack LEDs	79
Fan locations	80
Hot-plug fan LEDs	81
Cabling	82
BBWC cabling	82
Front panel cable components	82
SAS and SATA hard drive data cable routing	83
SAS and SATA power cable routing	83
Graphics card power cabling	84
Specifications	85
Environmental specifications	85
Server specifications	85
Technical support	87
Before you contact HP	87
HP contact information	87
Acronyms and abbreviations	88

Customer self repair

HP products are designed with many Customer Self Repair (CSR) parts to minimize repair time and allow for greater flexibility in performing defective parts replacement. If during the diagnosis period HP (or HP service providers or service partners) identifies that the repair can be accomplished by the use of a CSR part, HP will ship that part directly to you for replacement. There are two categories of CSR parts:

- **Mandatory**—Parts for which customer self repair is mandatory. If you request HP to replace these parts, you will be charged for the travel and labor costs of this service.
- **Optional**—Parts for which customer self repair is optional. These parts are also designed for customer self repair. If, however, you require that HP replace them for you, there may or may not be additional charges, depending on the type of warranty service designated for your product.

NOTE: Some HP parts are not designed for customer self repair. In order to satisfy the customer warranty, HP requires that an authorized service provider replace the part. These parts are identified as "No" in the Illustrated Parts Catalog.

Based on availability and where geography permits, CSR parts will be shipped for next business day delivery. Same day or four-hour delivery may be offered at an additional charge where geography permits. If assistance is required, you can call the HP Technical Support Center and a technician will help you over the telephone. HP specifies in the materials shipped with a replacement CSR part whether a defective part must be returned to HP. In cases where it is required to return the defective part to HP, you must ship the defective part back to HP within a defined period of time, normally five (5) business days. The defective part must be returned with the associated documentation in the provided shipping material. Failure to return the defective part may result in HP billing you for the replacement. With a customer self repair, HP will pay all shipping and part return costs and determine the courier/carrier to be used.

For more information about HP's Customer Self Repair program, contact your local service provider. For the North American program, refer to the HP website (<http://www.hp.com/go/selfrepair>).

Parts only warranty service

Your HP Limited Warranty may include a parts only warranty service. Under the terms of parts only warranty service, HP will provide replacement parts free of charge.

For parts only warranty service, CSR part replacement is mandatory. If you request HP to replace these parts, you will be charged for the travel and labor costs of this service.

Réparation par le client (CSR)

Les produits HP comportent de nombreuses pièces CSR (Customer Self Repair = réparation par le client) afin de minimiser les délais de réparation et faciliter le remplacement des pièces défectueuses. Si pendant la période de diagnostic, HP (ou ses partenaires ou mainteneurs agréés) détermine que la réparation peut être effectuée à l'aide d'une pièce CSR, HP vous l'envoie directement. Il existe deux catégories de pièces CSR:

Obligatoire - Pièces pour lesquelles la réparation par le client est obligatoire. Si vous demandez à HP de remplacer ces pièces, les coûts de déplacement et main d'œuvre du service vous seront facturés.

Facultatif - Pièces pour lesquelles la réparation par le client est facultative. Ces pièces sont également conçues pour permettre au client d'effectuer lui-même la réparation. Toutefois, si vous demandez à HP de remplacer ces pièces, l'intervention peut ou non vous être facturée, selon le type de garantie applicable à votre produit.

REMARQUE: Certaines pièces HP ne sont pas conçues pour permettre au client d'effectuer lui-même la réparation. Pour que la garantie puisse s'appliquer, HP exige que le remplacement de la pièce soit effectué par un Mainteneur Agréé. Ces pièces sont identifiées par la mention "Non" dans le Catalogue illustré.

Les pièces CSR sont livrées le jour ouvré suivant, dans la limite des stocks disponibles et selon votre situation géographique. Si votre situation géographique le permet et que vous demandez une livraison le jour même ou dans les 4 heures, celle-ci vous sera facturée. Pour bénéficier d'une assistance téléphonique, appelez le Centre d'assistance technique HP. Dans les documents envoyés avec la pièce de rechange CSR, HP précise s'il est nécessaire de lui retourner la pièce défectueuse. Si c'est le cas, vous devez le faire dans le délai indiqué, généralement cinq (5) jours ouvrés. La pièce et sa documentation doivent être retournées dans l'emballage fourni. Si vous ne retournez pas la pièce défectueuse, HP se réserve le droit de vous facturer les coûts de remplacement. Dans le cas d'une pièce CSR, HP supporte l'ensemble des frais d'expédition et de retour, et détermine la société de courses ou le transporteur à utiliser.

Pour plus d'informations sur le programme CSR de HP, contactez votre Mainteneur Agréé local. Pour plus d'informations sur ce programme en Amérique du Nord, consultez le site Web HP (<http://www.hp.com/go/selfrepair>).

Service de garantie "pièces seules"

Votre garantie limitée HP peut inclure un service de garantie "pièces seules". Dans ce cas, les pièces de rechange fournies par HP ne sont pas facturées.

Dans le cadre de ce service, la réparation des pièces CSR par le client est obligatoire. Si vous demandez à HP de remplacer ces pièces, les coûts de déplacement et main d'œuvre du service vous seront facturés.

Riparazione da parte del cliente

Per abbreviare i tempi di riparazione e garantire una maggiore flessibilità nella sostituzione di parti difettose, i prodotti HP sono realizzati con numerosi componenti che possono essere riparati direttamente dal cliente (CSR, Customer Self Repair). Se in fase di diagnostica HP (o un centro di servizi o di assistenza HP) identifica il guasto come riparabile mediante un ricambio CSR, HP lo spedisce direttamente al cliente per la sostituzione. Vi sono due categorie di parti CSR:

Obbligatorie – Parti che devono essere necessariamente riparate dal cliente. Se il cliente ne affida la riparazione ad HP, deve sostenere le spese di spedizione e di manodopera per il servizio.

Opzionali – Parti la cui riparazione da parte del cliente è facoltativa. Si tratta comunque di componenti progettati per questo scopo. Se tuttavia il cliente ne richiede la sostituzione ad HP, potrebbe dover sostenere spese addizionali a seconda del tipo di garanzia previsto per il prodotto.

NOTA: alcuni componenti HP non sono progettati per la riparazione da parte del cliente. Per rispettare la garanzia, HP richiede che queste parti siano sostituite da un centro di assistenza autorizzato. Tali parti sono identificate da un "No" nel Catalogo illustrato dei componenti.

In base alla disponibilità e alla località geografica, le parti CSR vengono spedite con consegna entro il giorno lavorativo seguente. La consegna nel giorno stesso o entro quattro ore è offerta con un supplemento di costo solo in alcune zone. In caso di necessità si può richiedere l'assistenza telefonica di un addetto del centro di supporto tecnico HP. Nel materiale fornito con una parte di ricambio CSR, HP specifica se il cliente deve restituire dei componenti. Qualora sia richiesta la resa ad HP del componente difettoso, lo si deve spedire ad HP entro un determinato periodo di tempo, generalmente cinque (5) giorni lavorativi. Il componente difettoso deve essere restituito con la documentazione associata nell'imballo di spedizione fornito. La mancata restituzione del componente può comportare la fatturazione del ricambio da parte di HP. Nel caso di riparazione da parte del cliente, HP sostiene tutte le spese di spedizione e resa e sceglie il corriere/vettore da utilizzare.

Per ulteriori informazioni sul programma CSR di HP contattare il centro di assistenza di zona. Per il programma in Nord America fare riferimento al sito Web HP (<http://www.hp.com/go/selfrepair>).

Servizio di garanzia per i soli componenti

La garanzia limitata HP può includere un servizio di garanzia per i soli componenti. Nei termini di garanzia del servizio per i soli componenti, HP fornirà gratuitamente le parti di ricambio.

Per il servizio di garanzia per i soli componenti è obbligatoria la formula CSR che prevede la riparazione da parte del cliente. Se il cliente invece richiede la sostituzione ad HP, dovrà sostenere le spese di spedizione e di manodopera per il servizio.

Customer Self Repair

HP Produkte enthalten viele CSR-Teile (Customer Self Repair), um Reparaturzeiten zu minimieren und höhere Flexibilität beim Austausch defekter Bauteile zu ermöglichen. Wenn HP (oder ein HP Servicepartner) bei der Diagnose feststellt, dass das Produkt mithilfe eines CSR-Teils repariert werden kann, sendet Ihnen HP dieses Bauteil zum Austausch direkt zu. CSR-Teile werden in zwei Kategorien unterteilt:

Zwingend – Teile, für die das Customer Self Repair-Verfahren zwingend vorgegeben ist. Wenn Sie den Austausch dieser Teile von HP vornehmen lassen, werden Ihnen die Anfahrt- und Arbeitskosten für diesen Service berechnet.

Optional – Teile, für die das Customer Self Repair-Verfahren optional ist. Diese Teile sind auch für Customer Self Repair ausgelegt. Wenn Sie jedoch den Austausch dieser Teile von HP vornehmen lassen möchten, können bei diesem Service je nach den für Ihr Produkt vorgesehenen Garantiebedingungen zusätzliche Kosten anfallen.

HINWEIS: Einige Teile sind nicht für Customer Self Repair ausgelegt. Um den Garantieanspruch des Kunden zu erfüllen, muss das Teil von einem HP Servicepartner ersetzt werden. Im illustrierten Teilekatalog sind diese Teile mit „No“ bzw. „Nein“ gekennzeichnet.

CSR-Teile werden abhängig von der Verfügbarkeit und vom Lieferziel am folgenden Geschäftstag geliefert. Für bestimmte Standorte ist eine Lieferung am selben Tag oder innerhalb von vier Stunden gegen einen Aufpreis verfügbar. Wenn Sie Hilfe benötigen, können Sie das HP technische Support Center

anrufen und sich von einem Mitarbeiter per Telefon helfen lassen. Den Materialien, die mit einem CSR-Ersatzteil geliefert werden, können Sie entnehmen, ob das defekte Teil an HP zurückgeschickt werden muss. Wenn es erforderlich ist, das defekte Teil an HP zurückzuschicken, müssen Sie dies innerhalb eines vorgegebenen Zeitraums tun, in der Regel innerhalb von fünf (5) Geschäftstagen. Das defekte Teil muss mit der zugehörigen Dokumentation in der Verpackung zurückgeschickt werden, die im Lieferumfang enthalten ist. Wenn Sie das defekte Teil nicht zurückschicken, kann HP Ihnen das Ersatzteil in Rechnung stellen. Im Falle von Customer Self Repair kommt HP für alle Kosten für die Lieferung und Rücksendung auf und bestimmt den Kurier-/Frachtdienst.

Weitere Informationen über das HP Customer Self Repair Programm erhalten Sie von Ihrem Servicepartner vor Ort. Informationen über das CSR-Programm in Nordamerika finden Sie auf der HP Website unter (<http://www.hp.com/go/selfrepair>).

Parts-only Warranty Service (Garantieservice ausschließlich für Teile)

Ihre HP Garantie umfasst möglicherweise einen Parts-only Warranty Service (Garantieservice ausschließlich für Teile). Gemäß den Bestimmungen des Parts-only Warranty Service stellt HP Ersatzteile kostenlos zur Verfügung.

Für den Parts-only Warranty Service ist das CSR-Verfahren zwingend vorgegeben. Wenn Sie den Austausch dieser Teile von HP vornehmen lassen, werden Ihnen die Anfahrt- und Arbeitskosten für diesen Service berechnet.

Reparaciones del propio cliente

Los productos de HP incluyen muchos componentes que el propio usuario puede reemplazar (*Customer Self Repair*, CSR) para minimizar el tiempo de reparación y ofrecer una mayor flexibilidad a la hora de realizar sustituciones de componentes defectuosos. Si, durante la fase de diagnóstico, HP (o los proveedores o socios de servicio de HP) identifica que una reparación puede llevarse a cabo mediante el uso de un componente CSR, HP le enviará dicho componente directamente para que realice su sustitución. Los componentes CSR se clasifican en dos categorías:

- **Obligatorio:** componentes para los que la reparación por parte del usuario es obligatoria. Si solicita a HP que realice la sustitución de estos componentes, tendrá que hacerse cargo de los gastos de desplazamiento y de mano de obra de dicho servicio.
- **Opcional:** componentes para los que la reparación por parte del usuario es opcional. Estos componentes también están diseñados para que puedan ser reparados por el usuario. Sin embargo, si precisa que HP realice su sustitución, puede o no conllevar costes adicionales, dependiendo del tipo de servicio de garantía correspondiente al producto.

NOTA: Algunos componentes no están diseñados para que puedan ser reparados por el usuario. Para que el usuario haga valer su garantía, HP pone como condición que un proveedor de servicios autorizado realice la sustitución de estos componentes. Dichos componentes se identifican con la palabra "No" en el catálogo ilustrado de componentes.

Según la disponibilidad y la situación geográfica, los componentes CSR se enviarán para que lleguen a su destino al siguiente día laborable. Si la situación geográfica lo permite, se puede solicitar la entrega en el mismo día o en cuatro horas con un coste adicional. Si precisa asistencia técnica, puede llamar al

Centro de asistencia técnica de HP y recibirá ayuda telefónica por parte de un técnico. Con el envío de materiales para la sustitución de componentes CSR, HP especificará si los componentes defectuosos deberán devolverse a HP. En aquellos casos en los que sea necesario devolver algún componente a HP, deberá hacerlo en el periodo de tiempo especificado, normalmente cinco días laborables. Los componentes defectuosos deberán devolverse con toda la documentación relacionada y con el embalaje de envío. Si no enviara el componente defectuoso requerido, HP podrá cobrarle por el de sustitución. En el caso de todas sustituciones que lleve a cabo el cliente, HP se hará cargo de todos los gastos de envío y devolución de componentes y escogerá la empresa de transporte que se utilice para dicho servicio.

Para obtener más información acerca del programa de Reparaciones del propio cliente de HP, póngase en contacto con su proveedor de servicios local. Si está interesado en el programa para Norteamérica, visite la página web de HP siguiente (<http://www.hp.com/go/selfrepair>).

Servicio de garantía exclusivo de componentes

La garantía limitada de HP puede que incluya un servicio de garantía exclusivo de componentes. Según las condiciones de este servicio exclusivo de componentes, HP le facilitará los componentes de repuesto sin cargo adicional alguno.

Para este servicio de garantía exclusivo de componentes, es obligatoria la sustitución de componentes por parte del usuario (CSR). Si solicita a HP que realice la sustitución de estos componentes, tendrá que hacerse cargo de los gastos de desplazamiento y de mano de obra de dicho servicio.

Customer Self Repair

Veel onderdelen in HP producten zijn door de klant zelf te repareren, waardoor de reparatieduur tot een minimum beperkt kan blijven en de flexibiliteit in het vervangen van defecte onderdelen groter is. Deze onderdelen worden CSR-onderdelen (Customer Self Repair) genoemd. Als HP (of een HP Service Partner) bij de diagnose vaststelt dat de reparatie kan worden uitgevoerd met een CSR-onderdeel, verzendt HP dat onderdeel rechtstreeks naar u, zodat u het defecte onderdeel daarmee kunt vervangen. Er zijn twee categorieën CSR-onderdelen:

Verplicht: Onderdelen waarvoor reparatie door de klant verplicht is. Als u HP verzoekt deze onderdelen voor u te vervangen, worden u voor deze service reiskosten en arbeidsloon in rekening gebracht.

Optioneel: Onderdelen waarvoor reparatie door de klant optioneel is. Ook deze onderdelen zijn ontworpen voor reparatie door de klant. Als u echter HP verzoekt deze onderdelen voor u te vervangen, kunnen daarvoor extra kosten in rekening worden gebracht, afhankelijk van het type garantieservice voor het product.

OPMERKING: Sommige HP onderdelen zijn niet ontwikkeld voor reparatie door de klant. In verband met de garantievooraarden moet het onderdeel door een geautoriseerde Service Partner worden vervangen. Deze onderdelen worden in de geïllustreerde onderdelencatalogus aangemerkt met "Nee".

Afhankelijk van de leverbaarheid en de locatie worden CSR-onderdelen verzonden voor levering op de eerstvolgende werkdag. Levering op dezelfde dag of binnen vier uur kan tegen meerkosten worden aangeboden, indien dit mogelijk is gezien de locatie. Indien assistentie gewenst is, belt u een HP Service Partner om via de telefoon technische ondersteuning te ontvangen. HP vermeldt in de documentatie bij het vervangende CSR-onderdeel of het defecte onderdeel aan HP moet worden geretourneerd. Als het defecte onderdeel aan HP moet worden teruggezonden, moet u het defecte onderdeel binnen een bepaalde periode, gewoonlijk vijf (5) werkdagen, retourneren aan HP. Het defecte onderdeel moet met de

bijbehorende documentatie worden geretourneerd in het meegeleverde verpakkingsmateriaal. Als u het defecte onderdeel niet terugzendt, kan HP u voor het vervangende onderdeel kosten in rekening brengen. Bij reparatie door de klant betaalt HP alle verzendkosten voor het vervangende en geretourneerde onderdeel en kiest HP zelf welke koerier/transportonderneming hiervoor wordt gebruikt.

Neem contact op met een Service Partner voor meer informatie over het Customer Self Repair programma van HP. Informatie over Service Partners vindt u op de HP website (<http://www.hp.com/go/selfrepair>).

Garantieservice "Parts Only"

Het is mogelijk dat de HP garantie alleen de garantieservice "Parts Only" omvat. Volgens de bepalingen van de Parts Only garantieservice zal HP kosteloos vervangende onderdelen ter beschikking stellen.

Voor de Parts Only garantieservice is vervanging door CSR-onderdelen verplicht. Als u HP verzoekt deze onderdelen voor u te vervangen, worden u voor deze service reiskosten en arbeidsloon in rekening gebracht.

Reparo feito pelo cliente

Os produtos da HP são projetados com muitas peças para reparo feito pelo cliente (CSR) de modo a minimizar o tempo de reparo e permitir maior flexibilidade na substituição de peças com defeito. Se, durante o período de diagnóstico, a HP (ou fornecedores/parceiros de serviço da HP) concluir que o reparo pode ser efetuado pelo uso de uma peça CSR, a peça de reposição será enviada diretamente ao cliente. Existem duas categorias de peças CSR:

Obrigatória – Peças cujo reparo feito pelo cliente é obrigatório. Se desejar que a HP substitua essas peças, serão cobradas as despesas de transporte e mão-de-obra do serviço.

Opcional – Peças cujo reparo feito pelo cliente é opcional. Essas peças também são projetadas para o reparo feito pelo cliente. No entanto, se desejar que a HP as substitua, pode haver ou não a cobrança de taxa adicional, dependendo do tipo de serviço de garantia destinado ao produto.

OBSERVAÇÃO: Algumas peças da HP não são projetadas para o reparo feito pelo cliente. A fim de cumprir a garantia do cliente, a HP exige que um técnico autorizado substitua a peça. Essas peças estão identificadas com a marca "No" (Não), no catálogo de peças ilustrado.

Conforme a disponibilidade e o local geográfico, as peças CSR serão enviadas no primeiro dia útil após o pedido. Onde as condições geográficas permitirem, a entrega no mesmo dia ou em quatro horas pode ser feita mediante uma taxa adicional. Se precisar de auxílio, entre em contato com o Centro de suporte técnico da HP para que um técnico o ajude por telefone. A HP especifica nos materiais fornecidos com a peça CSR de reposição se a peça com defeito deve ser devolvida à HP. Nos casos em que isso for necessário, é preciso enviar a peça com defeito à HP dentro do período determinado, normalmente cinco (5) dias úteis. A peça com defeito deve ser enviada com a documentação correspondente no material de transporte fornecido. Caso não o faça, a HP poderá cobrar a reposição. Para as peças de reparo feito pelo cliente, a HP paga todas as despesas de transporte e de devolução da peça e determina a transportadora/serviço postal a ser utilizado.

Para obter mais informações sobre o programa de reparo feito pelo cliente da HP, entre em contato com o fornecedor de serviços local. Para o programa norte-americano, visite o site da HP (<http://www.hp.com/go/selfrepair>).

Serviço de garantia apenas para peças

A garantia limitada da HP pode incluir um serviço de garantia apenas para peças. Segundo os termos do serviço de garantia apenas para peças, a HP fornece as peças de reposição sem cobrar nenhuma taxa.

No caso desse serviço, a substituição de peças CSR é obrigatória. Se desejar que a HP substitua essas peças, serão cobradas as despesas de transporte e mão-de-obra do serviço.

顧客自己修理保証サービス

修理時間を短縮し、故障部品の交換における高い柔軟性を確保するために、HP製品には多数の顧客自己修理（CSR）部品があります。診断の際に、CSR部品を使用すれば修理ができるとHP（HPまたはHP正規保守代理店）が判断した場合、HPはその部品を直接、お客様に発送し、お客様に交換していただきます。CSR部品には以下の2通りがあります。

- 必須 - 顧客自己修理が必須の部品。当該部品について、もしもお客様がHPに交換作業を依頼される場合には、その修理サービスに関する交通費および人件費がお客様に請求されます。
- 任意 - 顧客自己修理が任意である部品。この部品も顧客自己修理用です。当該部品について、もしもお客様がHPに交換作業を依頼される場合には、お買い上げの製品に適用される保証サービス内容の範囲内においては、別途費用を負担していただくことなく保証サービスを受けることができます。

注： HP製品の一部の部品は、顧客自己修理用ではありません。製品の保証を継続するためには、HPまたはHP正規保守代理店による交換作業が必須となります。部品カタログには、当該部品が顧客自己修理除外品である旨が記載されています。

部品供給が可能な場合、地域によっては、CSR部品を翌営業日に届くように発送します。また、地域によっては、追加費用を負担いただくことにより同日または4時間以内に届くように発送することも可能な場合があります。サポートが必要なときは、HPの修理受付窓口にご連絡いただければ、技術者が電話でアドバイスします。交換用のCSR部品または同梱物には、故障部品をHPに返送する必要があるかどうかが表示されています。故障部品をHPに返送する必要がある場合は、指定期限内（通常は5営業日以内）に故障部品をHPに返送してください。故障部品を返送する場合は、届いた時の梱包箱に関連書類とともに入れてください。故障部品を返送しない場合、HPから部品費用が請求されます。顧客自己修理の際には、HPは送料および部品返送料を全額負担し、使用する宅配便会社や運送会社を指定します。

部品のみ保証サービス

HP保証サービスには、部品のみ保証サービスが適用される場合があります。このサービスでは、交換部品は無償で提供されます。

部品のみ保証サービスにおいては、CSR部品をお客様により交換作業していただくことが必須となります。当該部品について、もしもお客様がHPに交換作業を依頼される場合には、その修理サービスに関する交通費および人件費はお客様の負担となります。

客户自行维修

HP 产品提供许多客户自行维修 (CSR) 部件，以尽可能缩短维修时间和在更换缺陷部件方面提供更大的灵活性。如果在诊断期间 HP（或 HP 服务提供商或服务合作伙伴）确定可以通过使用 CSR 部件完成维修，HP 将直接把该部件发送给您进行更换。有两类 CSR 部件：

- **强制性的** — 要求客户必须自行维修的部件。如果您请求 HP 更换这些部件，则必须为该服务支付差旅费和人工费用。
- **可选的** — 客户可以选择是否自行维修的部件。这些部件也是为客户自行维修设计的。不过，如果您要求 HP 为您更换这些部件，则根据为您的产品指定的保修服务类型，HP 可能收取或不再收取任何附加费用。

注：某些 HP 部件的设计并未考虑客户自行维修。为了满足客户保修的需要，HP 要求授权服务提供商更换相关部件。这些部件在部件图解目录中标记为“否”。

CSR 部件将在下一个工作日发运（取决于备货情况和允许的地理范围）。在允许的地理范围内，可在当天或四小时内发运，但要收取额外费用。如果需要帮助，您可以致电 HP 技术支持中心，将会有技术人员通过电话为您提供帮助。HP 会在随更换的 CSR 部件发运的材料中指明是否必须将有缺陷的部件返还给 HP。如果要求您将有缺陷的部件返还给 HP，那么您必须在规定期限内（通常是五 (5) 个工作日）将缺陷部件发给 HP。有缺陷的部件必须随所提供的发运材料中的相关文件一起返还。如果未能送还有缺陷的部件，HP 可能会要求您支付更换费用。客户自行维修时，HP 将承担所有相关运输和部件返回费用，并指定快递商/承运商。

有关 HP 客户自行维修计划的详细信息，请与您当地的服务提供商联系。有关北美地区的计划，请访问 HP 网站 (<http://www.hp.com/go/selfrepair>)。

仅部件保修服务

您的 HP 有限保修服务可能涉及仅部件保修服务。根据仅部件保修服务条款的规定，HP 将免费提供更换的部件。

仅部件保修服务要求进行 CSR 部件更换。如果您请求 HP 更换这些部件，则必须为该服务支付差旅费和人工费用。

客戶自行維修

HP 產品設計了許多「客戶自行維修」(CSR) 的零件以減少維修時間，並且使得更換瑕疵零件時能有更大的彈性。如果在診斷期間 HP（或 HP 服務供應商或維修夥伴）辨認出此項維修工作可以藉由使用 CSR 零件來完成，則 HP 將直接寄送該零件給您作更換。CSR 零件分為兩種類別：

- **強制的** — 客戶自行維修所使用的零件是強制性的。如果您要求 HP 更換這些零件，HP 將會向您收取此服務所需的外出費用與勞動成本。
- **選購的** — 客戶自行維修所使用的零件是選購的。這些零件也設計用於客戶自行維修之用。不過，如果您要求 HP 為您更換，則可能需要也可能不需要負擔額外的費用，端視針對此產品指定的保固服務類型而定。

備註：某些 HP 零件沒有消費者可自行維修的設計。為符合客戶保固，HP 需要授權的服務供應商更換零件。這些零件在圖示的零件目錄中，被標示為「否」。

基於材料取得及環境允許的情況下，CSR 零件將於下一個工作日以快遞寄送。在環境的允許下當天或四小時內送達，則可能需要額外的費用。若您需要協助，可致電「HP 技術支援中心」，會有一位技術人員透過電話來協助您。不論損壞的零件是否必須退回，HP 皆會在與 CSR 替換零件一起運送的材料中註明。若要將損壞的零件退回 HP，您必須在指定的一段時間內（通常為五 (5) 個工作天），將損壞的零件寄回 HP。損壞的零件必須與寄送資料中隨附的相關技術文件一併退還。如果無法退還損壞的零件，HP 可能要向您收取替換費用。針對客戶自行維修情形，HP 將負責所有運費及零件退還費用並指定使用何家快遞/貨運公司。

如需 HP 的「客戶自行維修」方案詳細資訊，請連絡您當地的服務供應商。至於北美方案，請參閱 HP 網站 (<http://www.hp.com/go/selfrepair>)。

僅限零件的保固服務

您的「HP 有限保固」可能包含僅限零件的保固服務。在僅限零件的保固服務情況下，HP 將免費提供替換零件。

針對僅限零件的保固服務，CSR 零件替換是強制性的。如果您要求 HP 更換這些零件，HP 將會向您收取此服務所需的外出費用與勞動成本。

고객 셀프 수리

HP 제품은 수리 시간을 최소화하고 결함이 있는 부품 교체 시 더욱 융통성을 발휘할 수 있도록 하기 위해 고객 셀프 수리(CSR) 부품을 다량 사용하여 설계되었습니다. 진단 기간 동안 HP(또는 HP 서비스 공급업체 또는 서비스 협력업체)에서 CSR 부품을 사용하여 수리가 가능하다고 판단되면 HP는 해당 부품을 바로 사용자에게 보내어 사용자가 교체할 수 있도록 합니다. CSR 부품에는 두 가지 종류가 있습니다.

- **고객 셀프 수리가 의무 사항인 필수 부품.** 사용자가 HP에 이 부품의 교체를 요청할 경우 이 서비스에 대한 출장비 및 작업비가 청구됩니다.
- **고객 셀프 수리가 선택 사항인 부품.** 이 부품들도 고객 셀프 수리가 가능하도록 설계되었습니다. 하지만 사용자가 HP에 이 부품의 교체를 요청할 경우 사용자가 구입한 제품에 해당하는 보증 서비스 유형에 따라 추가 비용 없이 교체가 가능할 수 있습니다.

참고: 일부 HP 부품은 고객 셀프 수리가 불가능하도록 설계되었습니다. HP는 만족스러운 고객 보증을 위해 공인 서비스 제공업체를 통해 부품을 교체하도록 하고 있습니다. 이러한 부품들은 Illustrated Parts Catalog에 "No"라고 표시되어 있습니다.

CSR 부품은 재고 상태와 지리적 조건이 허용하는 경우 다음 영업일 납품이 가능하도록 배송이 이루어집니다. 지리적 조건이 허용하는 경우 추가 비용이 청구되는 조건으로 당일 또는 4시간 배송이 가능할 수도 있습니다. 도움이 필요하시면 HP 기술 지원 센터로 전화하십시오. 전문 기술자가 전화로 도움을 줄 것입니다. HP는 결함이 발생한 부품을 HP로 반환해야 하는지 여부를 CSR 교체 부품과 함께 배송된 자료에 지정합니다. 결함이 발생한 부품을 HP로 반환해야 하는 경우에는 지정된 기간 내(통상 영업일 기준 5일)에 HP로 반환해야 합니다. 이 때 결함이 발생한 부품은 제공된 포장 재료에 넣어 관련 설명서와 함께 반환해야 합니다. 결함이 발생한 부품을 반환하지 않는 경우 HP가 교체 부품에 대해 비용을 청구할 수 있습니다. 고객 셀프 수리의 경우, HP는 모든 운송 및 부품 반환 비용을 부담하며 이용할 운송업체 및 택배 서비스를 결정합니다.

HP 고객 셀프 수리 프로그램에 대한 자세한 내용은 가까운 서비스 제공업체에 문의하십시오. 북미 지역의 프로그램에 대해서는 HP 웹 사이트(<http://www.hp.com/go/selfrepair>)를 참조하십시오.

부품 제공 보증 서비스

HP 제한 보증에는 부품 제공 보증 서비스가 포함될 수 있습니다. 이러한 경우 HP는 부품 제공 보증 서비스의 조건에 따라 교체 부품만을 무료로 제공합니다.

부품 제공 보증 서비스 제공 시 CSR 부품 교체는 의무 사항입니다. 사용자가 HP에 이 부품의 교체를 요청할 경우 이 서비스에 대한 출장비 및 작업비가 청구됩니다.

Illustrated parts catalog

Mechanical components

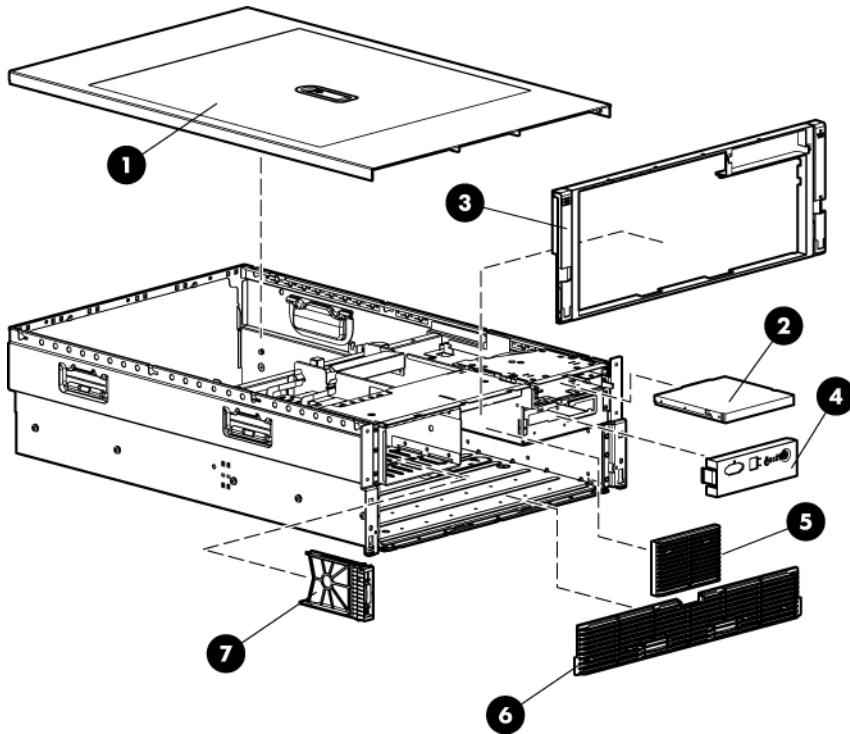

Item	Description	Assembly part number	Spare part number	Customer self repair (on page 6)
1	Access panel	367572-002	419905-001	Mandatory ¹
2	Blank, media drive	377569-001	409006-001	Mandatory ¹
—	Bezel kit	—	419897-001	Mandatory ¹
3	Front bezel	414072-001	—	Mandatory ¹
4	Power assembly bezel	414073-001	—	Mandatory ¹
—	Bezel kit, processor memory module*	—	419904-001	Mandatory ¹
5	Processor memory module fan bezel	414122-001	—	Mandatory ¹
6	Processor memory module bezel	414119-001	—	Mandatory ¹
7	Blank, SAS/SATA hard drive	376383-001	392613-001	Mandatory ¹
8	Tool, Torx, T-15*	107473-001	199630-001	Mandatory ¹

*Not shown

¹Mandatory—Parts for which customer self repair is mandatory. If you request HP to replace these parts, you will be charged for the travel and labor costs of this service.

²Optional—Parts for which customer self repair is optional. These parts are also designed for customer self repair. If, however, you require that HP replace them for you, there may or may not be additional charges, depending on the type of warranty service designated for your product.

³No—Some HP parts are not designed for customer self repair. In order to satisfy the customer warranty, HP requires that an authorized service provider replace the part. These parts are identified as "No" in the Illustrated Parts Catalog.

¹Mandatory: Obligatoire—Pièces pour lesquelles la réparation par le client est obligatoire. Si vous demandez à HP de remplacer ces pièces, les coûts de déplacement et main d'œuvre du service vous seront facturés.

²Optional: Facultatif—Pièces pour lesquelles la réparation par le client est facultative. Ces pièces sont également conçues pour permettre au client d'effectuer lui-même la réparation. Toutefois, si vous demandez à HP de remplacer ces pièces, l'intervention peut ou non vous être facturée, selon le type de garantie applicable à votre produit.

³No: Non—Certaines pièces HP ne sont pas conçues pour permettre au client d'effectuer lui-même la réparation. Pour que la garantie puisse s'appliquer, HP exige que le remplacement de la pièce soit effectué par un Mainteneur Agréé. Ces pièces sont identifiées par la mention "Non" dans le Catalogue illustré.

¹Mandatory: Obbligatorie—Parti che devono essere necessariamente riparate dal cliente. Se il cliente ne affida la riparazione ad HP, deve sostenere le spese di spedizione e di manodopera per il servizio.

²Optional: Opzionali—Parti la cui riparazione da parte del cliente è facoltativa. Si tratta comunque di componenti progettati per questo scopo. Se tuttavia il cliente ne richiede la sostituzione ad HP, potrebbe dover sostenere spese addizionali a seconda del tipo di garanzia previsto per il prodotto.

³No: Non CSR—Alcuni componenti HP non sono progettati per la riparazione da parte del cliente. Per rispettare la garanzia, HP richiede che queste parti siano sostituite da un centro di assistenza autorizzato. Tali parti sono identificate da un "No" nel Catalogo illustrato dei componenti.

¹Mandatory: Zwingend—Teile, die im Rahmen des Customer Self Repair Programms ersetzt werden müssen. Wenn Sie diese Teile von HP ersetzen lassen, werden Ihnen die Versand- und Arbeitskosten für diesen Service berechnet.

²Optional: Optional—Teile, für die das Customer Self Repair-Verfahren optional ist. Diese Teile sind auch für Customer Self Repair ausgelegt. Wenn Sie jedoch den Austausch dieser Teile von HP vornehmen lassen möchten, können bei diesem Service je nach den für Ihr Produkt vorgesehenen Garantiebedingungen zusätzliche Kosten anfallen.

³No: Kein—Einige Teile sind nicht für Customer Self Repair ausgelegt. Um den Garantieanspruch des Kunden zu erfüllen, muss das Teil von einem HP Servicepartner ersetzt werden. Im illustrierten Teilekatalog sind diese Teile mit „No“ bzw. „Nein“ gekennzeichnet.

¹Mandatory: Obligatorio—componentes para los que la reparación por parte del usuario es obligatoria. Si solicita a HP que realice la sustitución de estos componentes, tendrá que hacerse cargo de los gastos de desplazamiento y de mano de obra de dicho servicio.

²Optional: Opcional— componentes para los que la reparación por parte del usuario es opcional. Estos componentes también están diseñados para que puedan ser reparados por el usuario. Sin embargo, si precisa que HP realice su sustitución, puede o no conllevar costes adicionales, dependiendo del tipo de servicio de garantía correspondiente al producto.

³No: No—Algunos componentes no están diseñados para que puedan ser reparados por el usuario. Para que el usuario haga valer su garantía, HP pone como condición que un proveedor de servicios autorizado realice la sustitución de estos componentes. Dichos componentes se identifican con la palabra "No" en el catálogo ilustrado de componentes.

¹Mandatory: Verplicht—Onderdelen waarvoor Customer Self Repair verplicht is. Als u HP verzoekt deze onderdelen te vervangen, komen de reiskosten en het arbeidsloon voor uw rekening.

²Optional: Optioneel—Onderdelen waarvoor reparatie door de klant optioneel is. Ook deze onderdelen zijn ontworpen voor reparatie door de klant. Als u echter HP verzoekt deze onderdelen voor u te vervangen, kunnen daarvoor extra kosten in rekening worden gebracht, afhankelijk van het type garantieservice voor het product.

³No: Nee—Sommige HP onderdelen zijn niet ontwikkeld voor reparatie door de klant. In verband met de garantievooraarden moet het onderdeel door een geautoriseerde Service Partner worden vervangen. Deze onderdelen worden in de geïllustreerde onderdelencatalogus aangemerkt met "Nee".

¹Mandatory: Obrigatória—Peças cujo reparo feito pelo cliente é obrigatório. Se desejar que a HP substitua essas peças, serão cobradas as despesas de transporte e mão-de-obra do serviço.

²Optional: Opcional—Peças cujo reparo feito pelo cliente é opcional. Essas peças também são projetadas para o reparo feito pelo cliente. No entanto, se desejar que a HP as substitua, pode haver ou não a cobrança de taxa adicional, dependendo do tipo de serviço de garantia destinado ao produto.

³No: Nenhuma—Algumas peças da HP não são projetadas para o reparo feito pelo cliente. A fim de cumprir a garantia do cliente, a HP exige que um técnico autorizado substitua a peça. Essas peças estão identificadas com a marca “No” (Não), no catálogo de peças ilustrado.

¹Mandatory : 必須・顧客自己修理が必須の部品。当該部品について、もしもお客様がHPに交換作業を依頼される場合には、その修理サービスに関する交通費および人件費がお客様に請求されます。

²Optional : 任意・顧客自己修理が任意である部品。この部品も顧客自己修理用です。当該部品について、もしもお客様がHPに交換作業を依頼される場合には、お買い上げの製品に適用される保証サービス内容の範囲内においては、費用を負担していただくことなく保証サービスを受けることができます。

³No : 除外・HP製品の一部の部品は、顧客自己修理用ではありません。製品の保証を継続するためには、HPまたはHP正規保守代理店による交換作業が必須となります。部品カタログには、当該部品が顧客自己修理除外品である旨が記載されています。

¹Mandatory: 强制性的 — 要求客户必须自行维修的部件。如果您请求 HP 更换这些部件，则必须为该服务支付差旅费和人工费用。

²Optional: 可选的 — 客户可以选择是否自行维修的部件。这些部件也是为客户自行维修设计的。不过，如果您要求 HP 为您更换这些部件，则根据为您的产品指定的保修服务类型，HP 可能收取或不再收取任何附加费用。

³No: 否 — 某些 HP 部件的设计并未考虑客户自行维修。为了满足客户保修的需要，HP 要求授权服务提供商更换相关部件。这些部件在部件图解目录中标记为“否”。

¹Mandatory: 强制的 — 客户自行维修所使用的零件是强制性的。如果您要求 HP 更换这些零件，HP 将会向您收取此服务所需的外出费用与劳动成本。

²Optional: 選購的 — 客户自行维修所使用的零件是選購的。這些零件也設計用於客戶自行維修之用。不過，如果您要求 HP 為您更換，則可能需要也可能不需要負擔額外的費用，端視針對此產品指定的保固服務類型而定。

³No: 否 — 某些 HP 零件沒有消費者可自行維修的設計。為符合客戶保固，HP 需要授權的服務供應商更換零件。這些零件在圖示的零件目錄中，被標示為「否」。

¹ Mandatory: 필수 — 고객 셀프 수리가 의무 사항인 필수 부품. 사용자가 HP에 이 부품의 교체를 요청할 경우 이 서비스에 대한 출장비 및 작업비가 청구됩니다.

² Optional: 옵션 — 고객 셀프 수리가 선택 사항인 부품. 이 부품들도 고객 셀프 수리가 가능하도록 설계되었습니다. 하지만 사용자가 HP에 이 부품의 교체를 요청할 경우 사용자가 구입한 제품에 해당하는 보증 서비스 유형에 따라 추가 비용 없이 교체가 가능할 수 있습니다.

³ No: No — 고객 셀프 수리가 불가능하도록 설계된 HP 부품. 이 부품들은 고객 셀프 수리가 불가능하도록 설계되었습니다. HP는 고객 보증을 만족시키기 위해 공인 서비스 제공업체를 통해 부품을 교체하도록 하고 있습니다.

System components

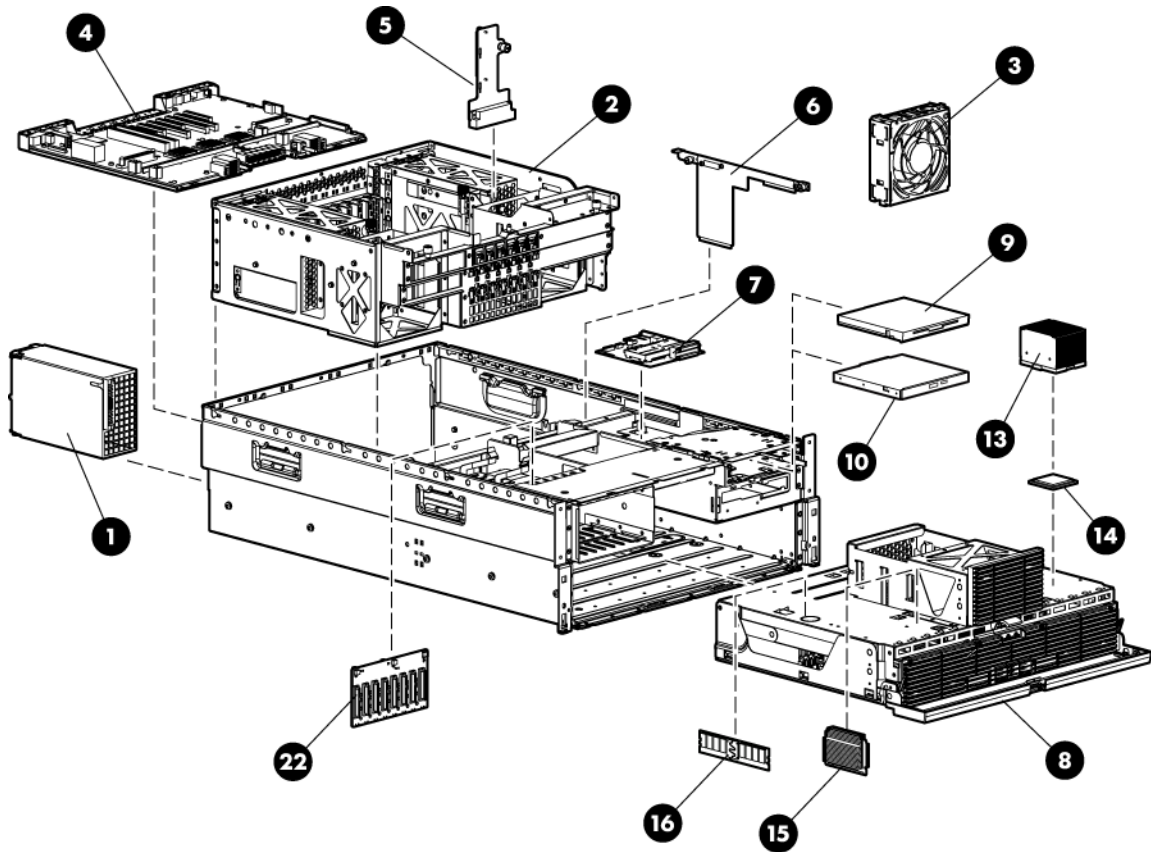

Item	Description	Assembly part number	Spare part number	Customer self repair (on page 6)
1	Power supply, 910–1300 W	337867-501	406421-001	Mandatory ¹
2	System cage	—	—	No ³
3	Fan, 120 mm, hot-plug	364517-001	374552-001	Mandatory ¹
	Boards			
4	System board	013241-001	463751-001	No ³
5	Power supply backplane	013263-001	501572-001	No ³
6	Pass-through board	012896-001	419621-001	Mandatory ¹
7	Media board with System Insight Display LEDs	012668-001	419619-001	Optional ²
8	Processor memory module	013208-001	454592-001	Optional ²
	Media drives			
9	Diskette drive, 3.5-in (optional)	263394-002	399396-001	Mandatory ¹
10	DVD/CD-RW drive	383696-002	399959-001	Mandatory ¹
11	DVD+RW drive, 8x (optional)*	395911-001	399402-001	Mandatory ¹
12	DVD drive, 8/24x (optional)*	395910-001	397928-001	Mandatory ¹

Item	Description	Assembly part number	Spare part number	Customer self repair (on page 6)
	Processor options			
13	Heatsink	415651-001	419898-001	Optional ²
14	AMD Opteron™ 8425HE 2.1-GHz 55W processor kit	539686-001	572551-001	Optional ²
—	AMD Opteron™ 8431 2.4-GHz 75W processor kit*	539451-002	539661-001	Optional ²
—	AMD Opteron™ 8439SE 2.8-GHz 75W processor kit*	539449-001	539659-001	Optional ²
—	AMD Opteron™ 8435 2.6-GHz 75W processor kit*	539451-001	539660-001	Optional ²
15	PPM	450967-001	578391-001	Mandatory ¹
	Memory			
16	DIMM, PC2-6400, 1 GB, 128Mx8	499275-061	501156-001	Mandatory ¹
—	DIMM, PC2-6400, 2 GB, 256Mx4*	499276-061	501157-001	Mandatory ¹
—	DIMM, PC2-6400, 4 GB, 256Mx4*	499277-061	501158-001	Mandatory ¹
—	DIMM, PC2-5300, 8 GB, 512Mx4*	405478-071	432671-001	Mandatory ¹
	SAS parts			
17	Smart Array P410 controller*	013233-001	462919-001	Optional ²
18	Smart Array cache module, 512 MB*	013224-002	462975-001	Optional ²
19	Smart Array BBWC battery pack*	460499-001	462976-001	Optional ²
20	Cable, BBWC battery pack to cache module (24-in)*	458943-002	488137-001	Mandatory ¹
21	Cable, SAS data*	495973-004	498430-001	Optional ²
22	SAS backplane board	012665-001	419618-001	Optional ²
	Cables			
23	Cable kit, data*	—	419906-001	Optional ²
—	Cable assembly, USB (dual, 15-in)*	404807-001	—	Optional ²
—	Cable assembly, video (15-in)*	392250-003	—	Optional ²
—	Cable assembly, SAS power (15-in)*	394038-002	—	Optional ²
—	Cable assembly, power button (16-in)*	367602-002	—	Optional ²
—	Cable assembly, PCI Express card power*	501711-001	578390-001	Optional ²
	Miscellaneous			
24	Battery, 3 V, Lithium*	166899-001	153099-001	Mandatory ¹
25	Rack mount kit, universal*	374503-001	377839-001	Mandatory ¹
26	AC power cord, C14–C19 (6-ft)*	287485-002	391097-001	Mandatory ¹
27	Hardware kit, miscellaneous*	—	385642-001	Mandatory ¹
—	CD/Diskette drive blank*	377569-001	—	Mandatory ¹

Item	Description	Assembly part number	Spare part number	Customer self repair (on page 6)
—	Blank, power supply*	366450-002	—	Mandatory ¹

*Not shown

¹Mandatory—Parts for which customer self repair is mandatory. If you request HP to replace these parts, you will be charged for the travel and labor costs of this service.

²Optional—Parts for which customer self repair is optional. These parts are also designed for customer self repair. If, however, you require that HP replace them for you, there may or may not be additional charges, depending on the type of warranty service designated for your product.

³No—Some HP parts are not designed for customer self repair. In order to satisfy the customer warranty, HP requires that an authorized service provider replace the part. These parts are identified as "No" in the Illustrated Parts Catalog.

¹Mandatory: Obligatoire—Pièces pour lesquelles la réparation par le client est obligatoire. Si vous demandez à HP de remplacer ces pièces, les coûts de déplacement et main d'œuvre du service vous seront facturés.

²Optional: Facultatif—Pièces pour lesquelles la réparation par le client est facultative. Ces pièces sont également conçues pour permettre au client d'effectuer lui-même la réparation. Toutefois, si vous demandez à HP de remplacer ces pièces, l'intervention peut ou non vous être facturée, selon le type de garantie applicable à votre produit.

³No: Non—Certaines pièces HP ne sont pas conçues pour permettre au client d'effectuer lui-même la réparation. Pour que la garantie puisse s'appliquer, HP exige que le remplacement de la pièce soit effectué par un Mainteneur Agréé. Ces pièces sont identifiées par la mention "Non" dans le Catalogue illustré.

¹Mandatory: Obbligatorie—Parti che devono essere necessariamente riparate dal cliente. Se il cliente ne affida la riparazione ad HP, deve sostenere le spese di spedizione e di manodopera per il servizio.

²Optional: Opzionali—Parti la cui riparazione da parte del cliente è facoltativa. Si tratta comunque di componenti progettati per questo scopo. Se tuttavia il cliente ne richiede la sostituzione ad HP, potrebbe dover sostenere spese aggiuntive a seconda del tipo di garanzia previsto per il prodotto.

³No: Non CSR—Alcuni componenti HP non sono progettati per la riparazione da parte del cliente. Per rispettare la garanzia, HP richiede che queste parti siano sostituite da un centro di assistenza autorizzato. Tali parti sono identificate da un "No" nel Catalogo illustrato dei componenti.

¹Mandatory: Zwingend—Teile, die im Rahmen des Customer Self Repair Programms ersetzt werden müssen. Wenn Sie diese Teile von HP ersetzen lassen, werden Ihnen die Versand- und Arbeitskosten für diesen Service berechnet.

²Optional: Optional—Teile, für die das Customer Self Repair-Verfahren optional ist. Diese Teile sind auch für Customer Self Repair ausgelegt. Wenn Sie jedoch den Austausch dieser Teile von HP vornehmen lassen möchten, können bei diesem Service je nach den für Ihr Produkt vorgesehenen Garantiebedingungen zusätzliche Kosten anfallen.

³No: Kein—Einige Teile sind nicht für Customer Self Repair ausgelegt. Um den Garantieanspruch des Kunden zu erfüllen, muss das Teil von einem HP Servicepartner ersetzt werden. Im illustrierten Teilekatalog sind diese Teile mit „No“ bzw. „Nein“ gekennzeichnet.

¹Mandatory: Obligatorio—componentes para los que la reparación por parte del usuario es obligatoria. Si solicita a HP que realice la sustitución de estos componentes, tendrá que hacerse cargo de los gastos de desplazamiento y de mano de obra de dicho servicio.

²Optional: Opcional— componentes para los que la reparación por parte del usuario es opcional. Estos componentes también están diseñados para que puedan ser reparados por el usuario. Sin embargo, si precisa que HP realice su sustitución, puede o no conllevar costes adicionales, dependiendo del tipo de servicio de garantía correspondiente al producto.

³No: No—Algunos componentes no están diseñados para que puedan ser reparados por el usuario. Para que el usuario haga valer su garantía, HP pone como condición que un proveedor de servicios autorizado realice la sustitución de estos componentes. Dichos componentes se identifican con la palabra "No" en el catálogo ilustrado de componentes.

¹Mandatory: Verplicht—Onderdelen waarvoor Customer Self Repair verplicht is. Als u HP verzoekt deze onderdelen te vervangen, komen de reiskosten en het arbeidsloon voor uw rekening.

²Optional: Optioneel—Onderdelen waarvoor reparatie door de klant optioneel is. Ook deze onderdelen zijn ontworpen voor reparatie door de klant. Als u echter HP verzoekt deze onderdelen voor u te vervangen, kunnen daarvoor extra kosten in rekening worden gebracht, afhankelijk van het type garantieservice voor het product.

³No: Nee—Sommige HP onderdelen zijn niet ontwikkeld voor reparatie door de klant. In verband met de garantievoorwaarden moet het onderdeel door een geautoriseerde Service Partner worden vervangen. Deze onderdelen worden in de geïllustreerde onderdelencatalogus aangemerkt met "Nee".

¹Mandatory: Obrigatória—Peças cujo reparo feito pelo cliente é obrigatório. Se desejar que a HP substitua essas peças, serão cobradas as despesas de transporte e mão-de-obra do serviço.

²Optional: Opcional—Peças cujo reparo feito pelo cliente é opcional. Essas peças também são projetadas para o reparo feito pelo cliente. No entanto, se desejar que a HP as substitua, pode haver ou não a cobrança de taxa adicional, dependendo do tipo de serviço de garantia destinado ao produto.

³No: Nenhuma—Algumas peças da HP não são projetadas para o reparo feito pelo cliente. A fim de cumprir a garantia do cliente, a HP exige que um técnico autorizado substitua a peça. Essas peças estão identificadas com a marca "No" (Não), no catálogo de peças ilustrado.

¹Mandatory : 必須 - 顧客自己修理が必須の部品。当該部品について、もしもお客様がHPに交換作業を依頼される場合には、その修理サービスに関する交通費および人件費がお客様に請求されます。

²Optional : 任意 - 顧客自己修理が任意である部品。この部品も顧客自己修理用です。当該部品について、もしもお客様がHPに交換作業を依頼される場合には、お買い上げの製品に適用される保証サービス内容の範囲内においては、費用を負担していただくことなく保証サービスを受けることができます。

³No : 除外 - HP製品の一部の部品は、顧客自己修理用ではありません。製品の保証を継続するためには、HPまたはHP正規保守代理店による交換作業が必須となります。部品カタログには、当該部品が顧客自己修理除外品である旨が記載されています。

¹Mandatory: 强制性的 — 要求客户必须自行维修的部件。如果您请求 HP 更换这些部件，则必须为该服务支付差旅费和人工费用。

²Optional: 可选的 — 客户可以选择是否自行维修的部件。这些部件也是为客户自行维修设计的。不过，如果您要求 HP 为您更换这些部件，则根据为您的产品指定的保修服务类型，HP 可能收取或不再收取任何附加费用。

³No: 否 — 某些 HP 部件的设计并未考虑客户自行维修。为了满足客户保修的需要，HP 要求授权服务提供商更换相关部件。这些部件在部件图解目录中标记为“否”。

¹Mandatory: 强制的 — 客户自行维修所使用的零件是强制性的。如果您要求 HP 更换这些零件，HP 将会向您收取此服务所需的外出费用与劳动成本。

²Optional: 選購的 — 客户自行维修所使用的零件是選購的。這些零件也設計用於客戶自行維修之用。不過，如果您要求 HP 為您更換，則可能需要也可能不需要負擔額外的費用，端視針對此產品指定的保固服務類型而定。

³No: 否 — 某些 HP 零件沒有消費者可自行維修的設計。為符合客戶保固，HP 需要授權的服務供應商更換零件。這些零件在圖示的零件目錄中，被標示為「否」。

¹ Mandatory: 필수 — 고객 셀프 수리가 의무 사항인 필수 부품. 사용자가 HP에 이 부품의 교체를 요청할 경우 이 서비스에 대한 출장비 및 작업비가 청구됩니다.

² Optional: 옵션 — 고객 셀프 수리가 선택 사항인 부품. 이 부품들도 고객 셀프 수리가 가능하도록 설계되었습니다. 하지만 사용자가 HP에 이 부품의 교체를 요청할 경우 사용자가 구입한 제품에 해당하는 보증 서비스 유형에 따라 추가 비용 없이 교체가 가능할 수 있습니다.

³ No: No — 고객 셀프 수리가 불가능하도록 설계된 HP 부품. 이 부품들은 고객 셀프 수리가 불가능하도록 설계되었습니다. HP는 고객 보증을 만족시키기 위해 공인 서비스 제공업체를 통해 부품을 교체하도록 하고 있습니다.

Removal and replacement procedures

Required tools

You need the following items for some procedures:

- Torx T-15 screwdriver (provided with the server ("Rear panel components" on page 72))
- Phillips screwdriver
- Flathead screwdriver
- Diagnostics Utility

Safety considerations

Before performing service procedures, review all the safety information.

Preventing electrostatic discharge

To prevent damaging the system, be aware of the precautions you need to follow when setting up the system or handling parts. A discharge of static electricity from a finger or other conductor may damage system boards or other static-sensitive devices. This type of damage may reduce the life expectancy of the device.

To prevent electrostatic damage:

- Avoid hand contact by transporting and storing products in static-safe containers.
- Keep electrostatic-sensitive parts in their containers until they arrive at static-free workstations.
- Place parts on a grounded surface before removing them from their containers.
- Avoid touching pins, leads, or circuitry.
- Always be properly grounded when touching a static-sensitive component or assembly.

Server warnings and cautions

Before installing a server, be sure that you understand the following warnings and cautions.



WARNING: To reduce the risk of electric shock or damage to the equipment:

- Do not disable the power cord grounding plug. The grounding plug is an important safety feature.
 - Plug the power cord into a grounded (earthed) electrical outlet that is easily accessible at all times.
 - Unplug the power cord from the power supply to disconnect power to the equipment.
 - Do not route the power cord where it can be walked on or pinched by items placed against it. Pay particular attention to the plug, electrical outlet, and the point where the cord extends from the server.
-

 **WARNING:** To reduce the risk of personal injury from hot surfaces, allow the drives and the internal system components to cool before touching them.

 **CAUTION:** Do not operate the server for long periods with the access panel open or removed. Operating the server in this manner results in improper airflow and improper cooling that can lead to thermal damage.

Preparation procedures

To access some components and perform certain service procedures, you must perform one or more of the following procedures:

- Power down the server (on page 25).
If you must remove a server from a rack or a non-hot-plug component from a server, power down the server.
- Extend the server from the rack ("Extending the server from the rack" on page 26).
If you are performing service procedures in an HP, Compaq branded, telco, or third-party rack, you can use the locking feature of the rack rails to support the server and gain access to internal components.
For more information about telco rack solutions, refer to the RackSolutions.com website (<http://www.racksolutions.com/hp>).
- Remove the server from the rack (on page 27).
If the rack environment, cabling configuration, or the server location in the rack creates awkward conditions, remove the server from the rack.
- Remove the access panel ("Removing the access panel" on page 27).
If you are servicing internal components, remove the access panel.

Power down the server

 **WARNING:** To reduce the risk of personal injury, electric shock, or damage to the equipment, remove the power cord to remove power from the server. The front panel Power On/Standby button does not completely shut off system power. Portions of the power supply and some internal circuitry remain active until AC power is removed.

 **IMPORTANT:** If installing a hot-plug device, it is not necessary to power down the server.

1. Shut down the OS as directed by the OS documentation.
2. Press the Power On/Standby button to place the server in standby mode. When the server enters standby power mode, the system power LED changes to amber.
3. Disconnect the power cords.

The system is now without power.

Extending the server from the rack

The design of the server enables you to access several components through the front of the server. Installing or accessing the following components will not require extending the server from the rack:

- Processors
- PPMs
- Processor memory board
- DIMMs
- DVD drive
- Optional diskette or CD-ROM drive
- Hard drives

To extend the server from the rack:

1. Pull down the quick-release levers on each side of the server to release the server from the rack.
2. Extend the server on the rack rails until the server rail-release latches engage.

NOTE: The release latches will lock into place when the rails are fully extended.

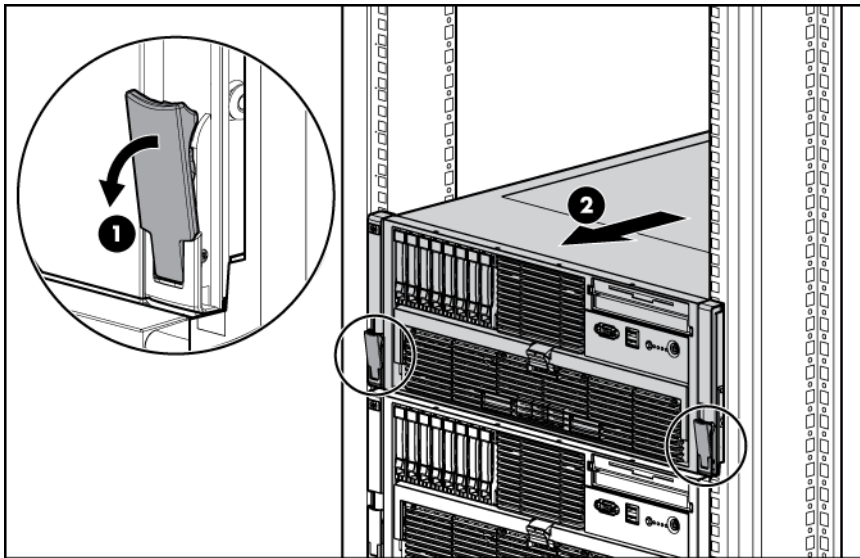

WARNING: To reduce the risk of personal injury or equipment damage, be sure that the rack is adequately stabilized before extending a component from the rack.



WARNING: To reduce the risk of personal injury, be careful when pressing the server rail-release latches and sliding the server into the rack. The sliding rails could pinch your fingers.

3. After performing the installation or maintenance procedure, slide the server into the rack by pressing the server rail-release latches.

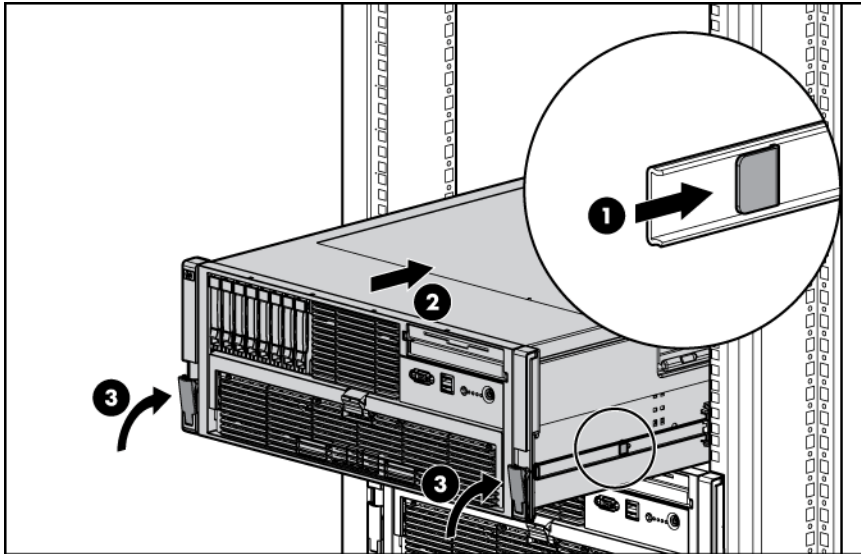

Remove the server from the rack

To remove the server from an HP, Compaq branded, telco, or third-party rack:

1. Power down the server (on page 25).
2. Extend the server from the rack ("Extending the server from the rack" on page 26).
3. Disconnect the cabling and remove the server from the rack. For more information, refer to the documentation that ships with the rack mounting option.
4. Place the server on a sturdy, level surface.

Removing the access panel

⚠ WARNING: To reduce the risk of personal injury from hot surfaces, allow the drives and the internal system components to cool before touching them.

⚠ CAUTION: Do not operate the server for long periods with the access panel open or removed. Operating the server in this manner results in improper airflow and improper cooling that can lead to thermal damage.

📝 IMPORTANT: When removing the access panel to view the Systems Insight Display LEDs (on page 77), leave the server powered on. The Systems Insight Display LEDs are cleared when the server is powered off.

1. Extend the server from the rack ("Extending the server from the rack" on page 26).
2. If the locking latch is locked, use a T-15 Torx screwdriver to unlock the latch.

NOTE: The T-15 Torx screwdriver is shipped with the server and can be located on the rear panel ("Rear panel components" on page 72).

3. Lift up on the hood latch, and remove the access panel.

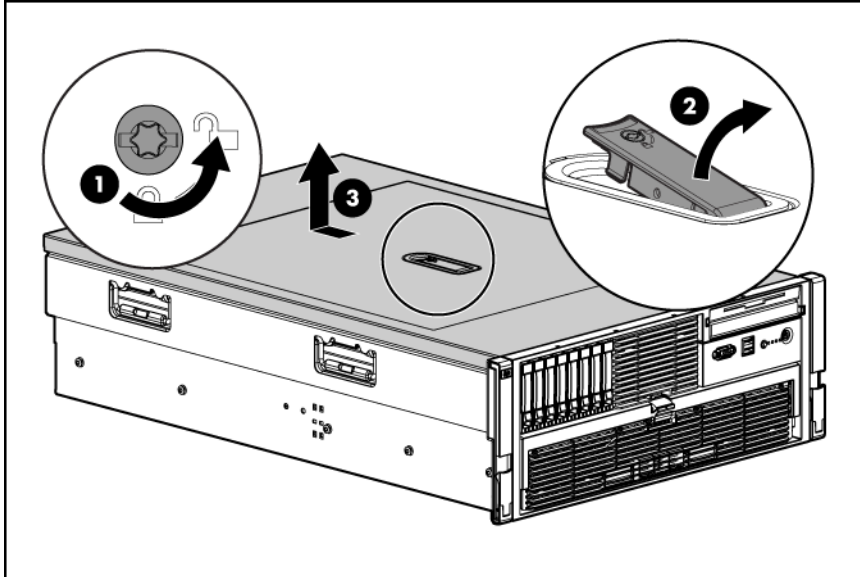

4. After installing hardware options, replace the access panel. Be sure that the panel is securely locked into place before powering up the server.

Removing the processor memory module

The processors and memory are stored in a module at the front of the server. Access to the processor memory module is provided through the front panel, eliminating the need to extend the server from the rack to install new or replace existing processors or upgrade the memory.

To remove the processor memory module:

1. Power down the server (on page 25).
2. Release the latches on the lever.
3. Lower the handle, and pull the processor memory module out of the server until the release latches catch.

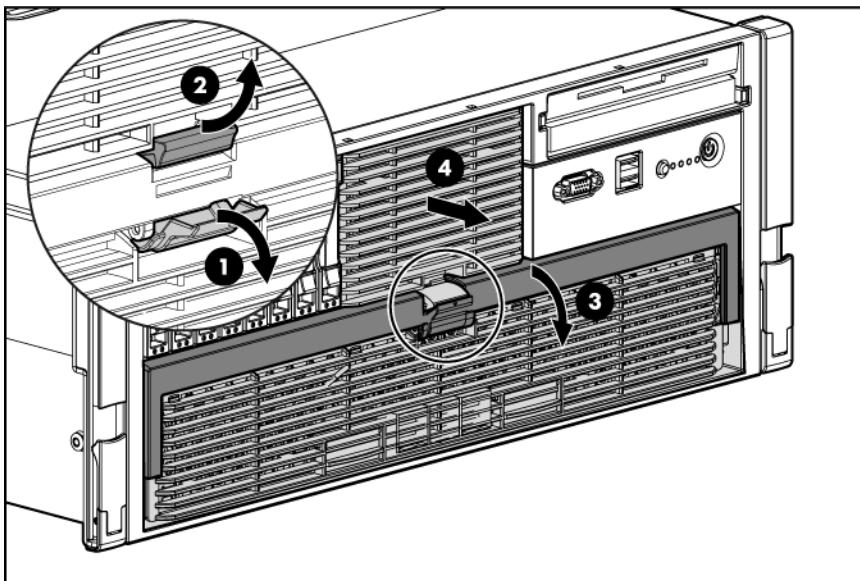



WARNING: Use caution when installing the processor memory module or removing the processor memory module; when fully populated, it can weigh up to 13.6 kg (30 lb).

4. Firmly holding the processor memory module, press the release buttons and pull the module out of the server.

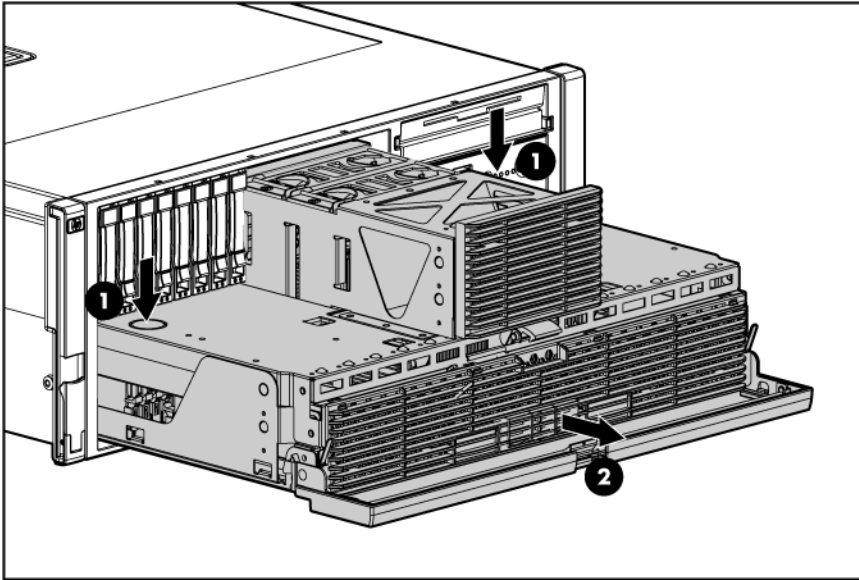

5. Remove the fans installed in the cover of the processor memory module.
6. Release the latch, and open the cover.

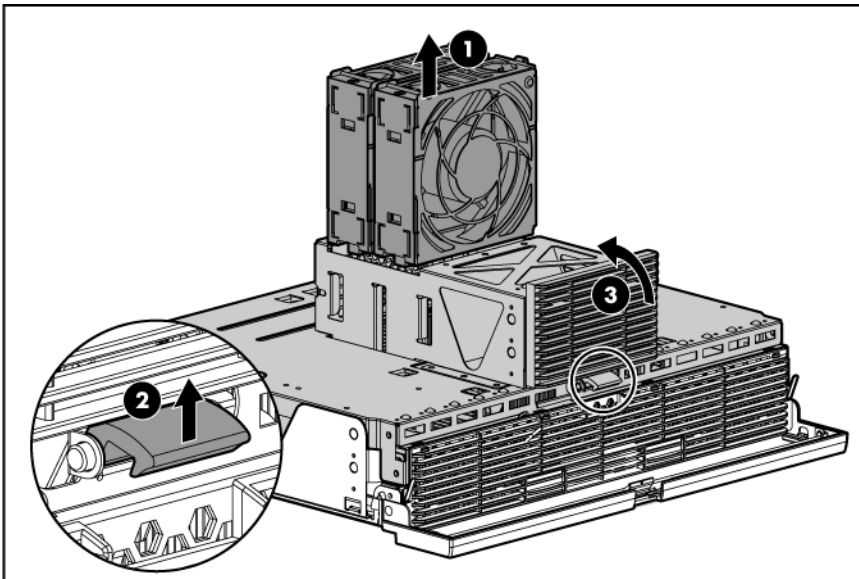

7. Close the processor memory module cover.

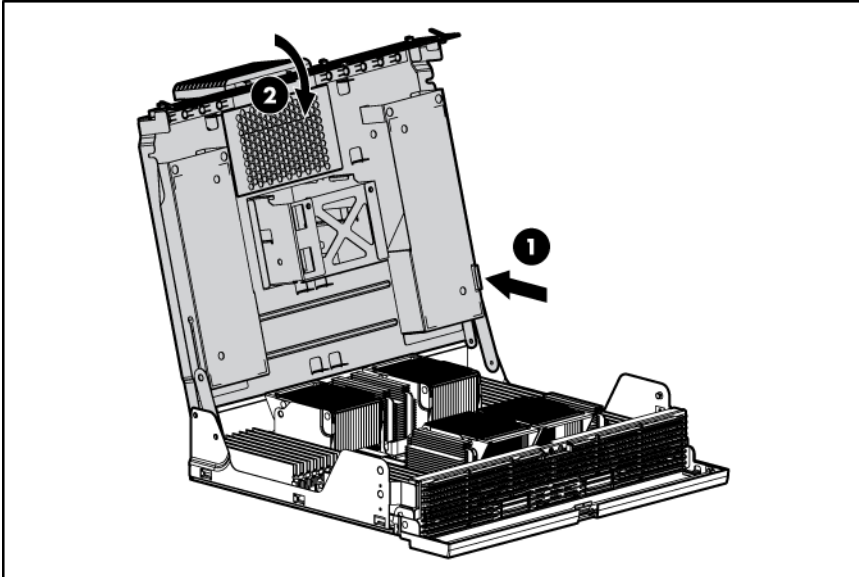

To replace the component, reverse the removal procedure.

Power button assembly bezel

⚠ WARNING: Use caution when installing the processor memory module or removing the processor memory module; when fully populated, it can weigh up to 13.6 kg (30 lb).

1. Remove the processor memory module ("Removing the processor memory module" on page 28).
2. Press the tab and pull the bezel away from the server.

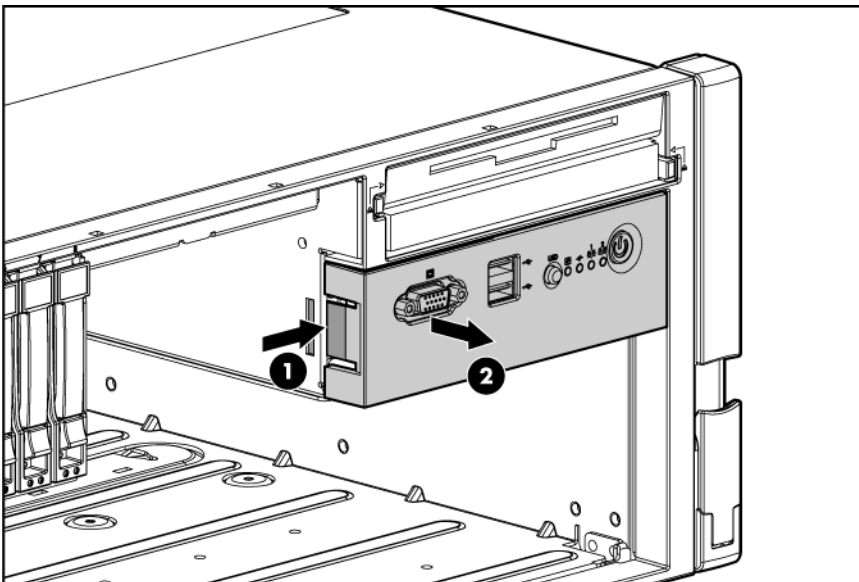

To replace the component, reverse the removal procedure.

USB cable assembly

1. Power down the server (on page 25).
2. Remove the processor memory module ("Removing the processor memory module" on page 28).
3. Extend or remove the server from the rack ("Remove the server from the rack" on page 27, "Extending the server from the rack" on page 26).
4. Remove the access panel ("Removing the access panel" on page 27).
5. Remove the power button assembly bezel (on page 30).
6. Disconnect the USB cable from the media board ("Front panel cable components" on page 82).
7. Remove the screws securing the USB cable assembly and remove the cable from the server.

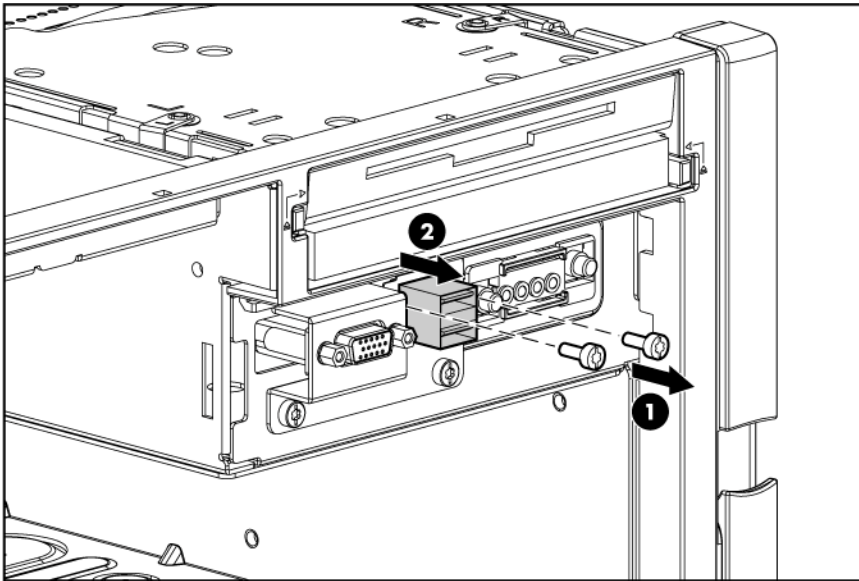

To replace the component, reverse the removal procedure.

Video cable assembly

1. Power down the server (on page 25).
2. Remove the processor memory module ("Removing the processor memory module" on page 28).
3. Extend or remove the server from the rack ("Remove the server from the rack" on page 27, "Extending the server from the rack" on page 26).
4. Remove the access panel ("Removing the access panel" on page 27).
5. Remove the power button assembly bezel (on page 30).
6. Disconnect the video cable from the media board ("Front panel cable components" on page 82).

7. Remove the screws securing the cable bracket to the server and remove the bracket.

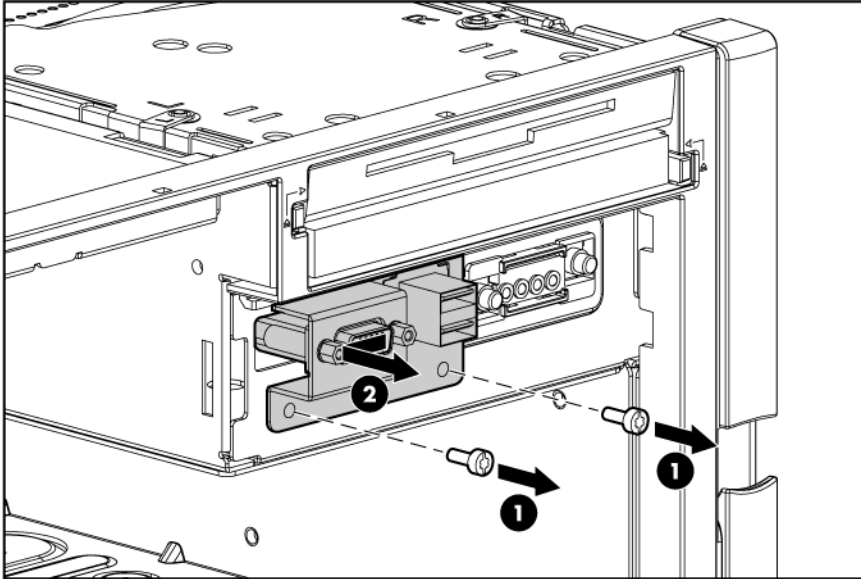

8. Remove the screws securing the video cable to the bracket and remove the cable.

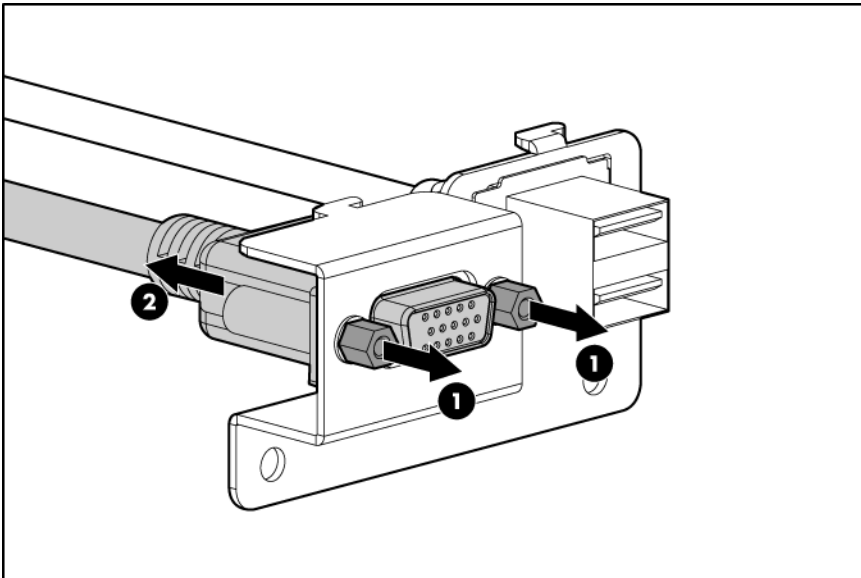

To replace the component, reverse the removal procedure.

Power button cable assembly

1. Power down the server (on page 25).
2. Remove the processor memory module ("Removing the processor memory module" on page 28).
3. Extend or remove the server from the rack ("Remove the server from the rack" on page 27, "Extending the server from the rack" on page 26).
4. Remove the access panel ("Removing the access panel" on page 27).
5. Remove the power button assembly bezel (on page 30).
6. Disconnect the power button cable from the media board ("Front panel cable components" on page 82).

7. Push up on the power button cable assembly to disconnect it from the server.

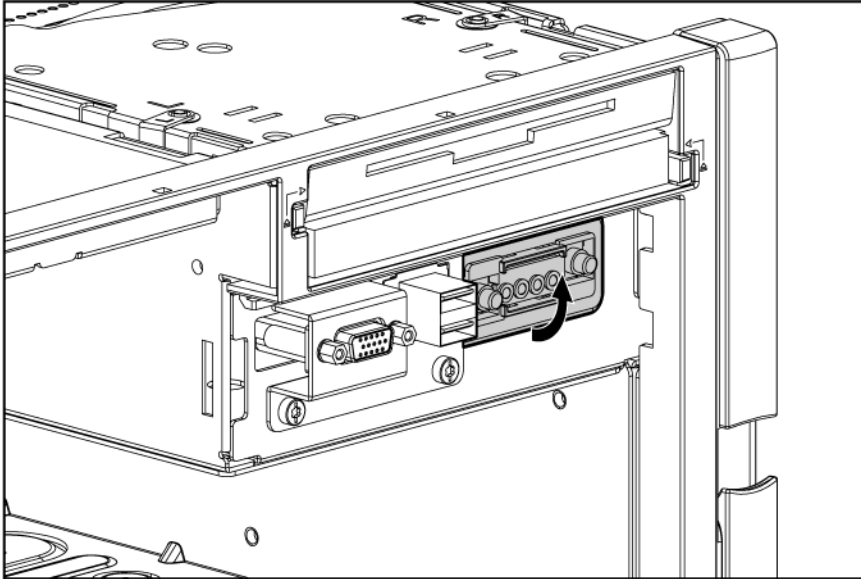

8. Pull the power button cable assembly away from the server.

To replace the component, reverse the removal procedure.

Fan cage bezel

1. Power down the server (on page 25).



WARNING: Use caution when installing the processor memory module or removing the processor memory module; when fully populated, it can weigh up to 13.6 kg (30 lb).

2. Remove the processor memory module ("Removing the processor memory module" on page 28).
3. Press the tabs behind the bezel and pull the bezel away from the server. If necessary, use a flathead screwdriver to press the tabs.

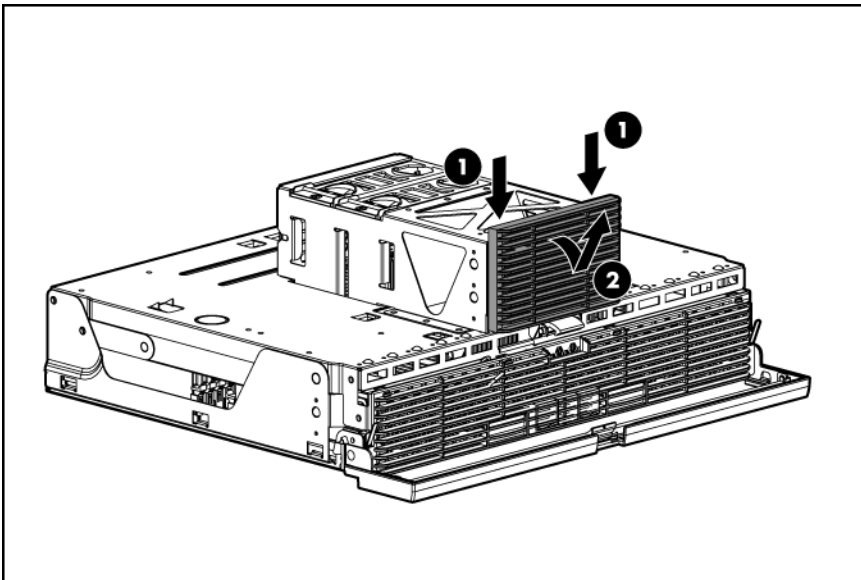

To replace the component, reverse the removal procedure.

Processor memory module bezel

1. Power down the server (on page 25).
2. Remove the processor memory module, and open the cover ("Removing the processor memory module" on page 28).
3. Press the tabs to disconnect the bottom of the bezel and pull the bezel away from the server. If necessary, use a flathead screwdriver to press the tabs.

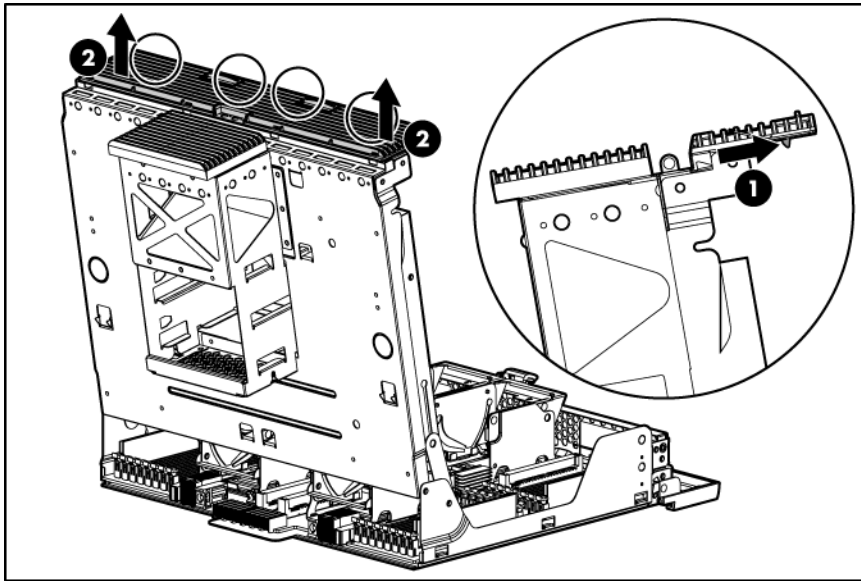

To replace the component, reverse the removal procedure.

Processors

CAUTION: Before starting this procedure, read the information about protecting against electrostatic discharge ("Preventing electrostatic discharge" on page 24).

CAUTION: Processor and PPM sockets 1 and 2 must be populated at all times or the server will not function properly.

To replace a processor:

1. Power down the server (on page 25).

WARNING: Use caution when installing the processor memory module or removing the processor memory module; when fully populated, it can weigh up to 13.6 kg (30 lb).

2. Remove the processor memory module, and open the cover ("Removing the processor memory module" on page 28).

WARNING: To reduce the risk of personal injury from hot surfaces, allow the heatsink to cool before touching it.

3. Open the heatsink retaining bracket.

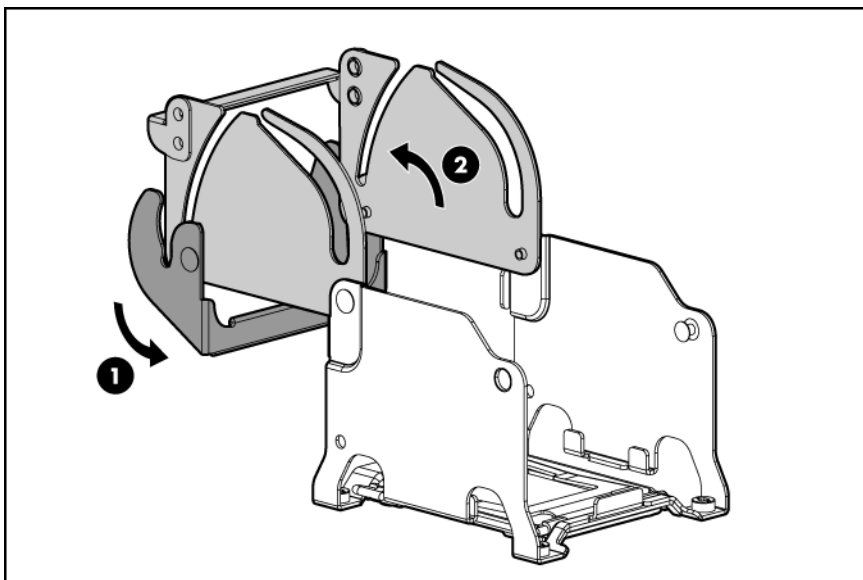

4. Remove the heatsink.

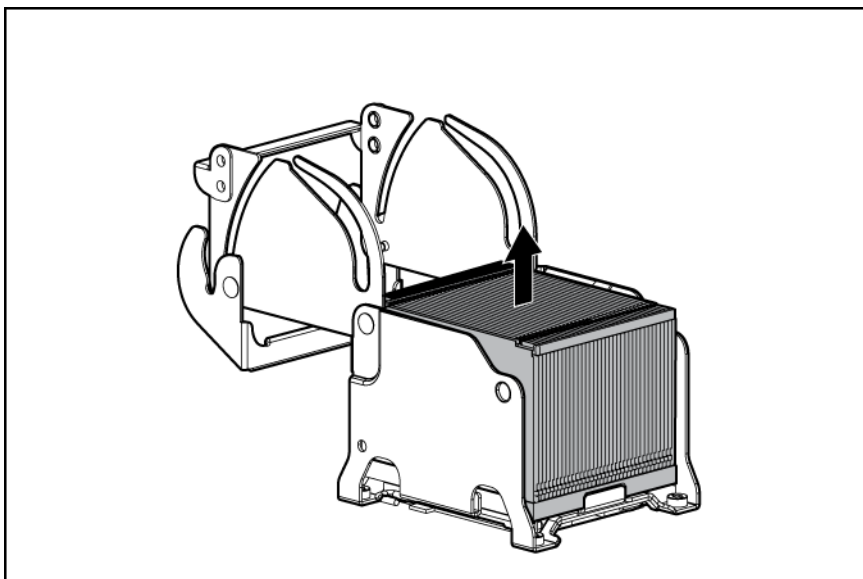

5. Open the processor retaining latch and the processor socket retaining bracket.

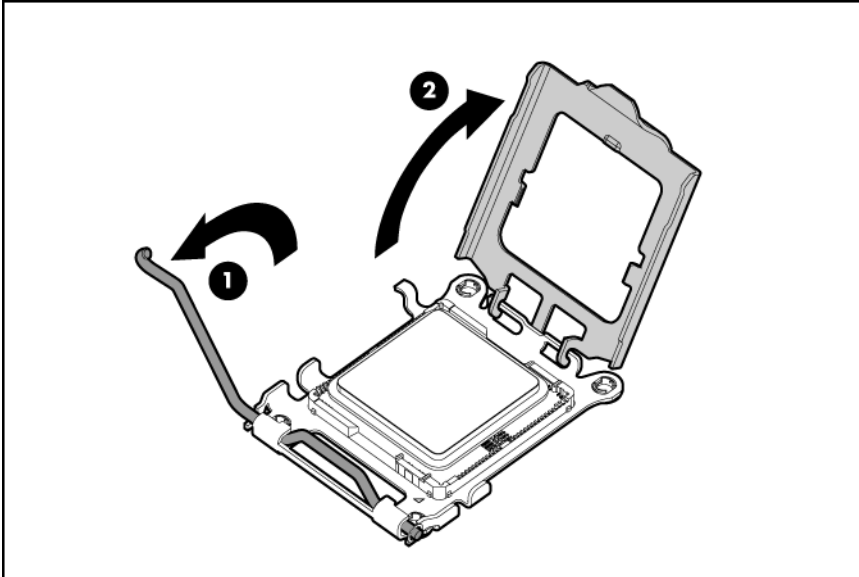

6. Using your fingers, remove the failed processor.

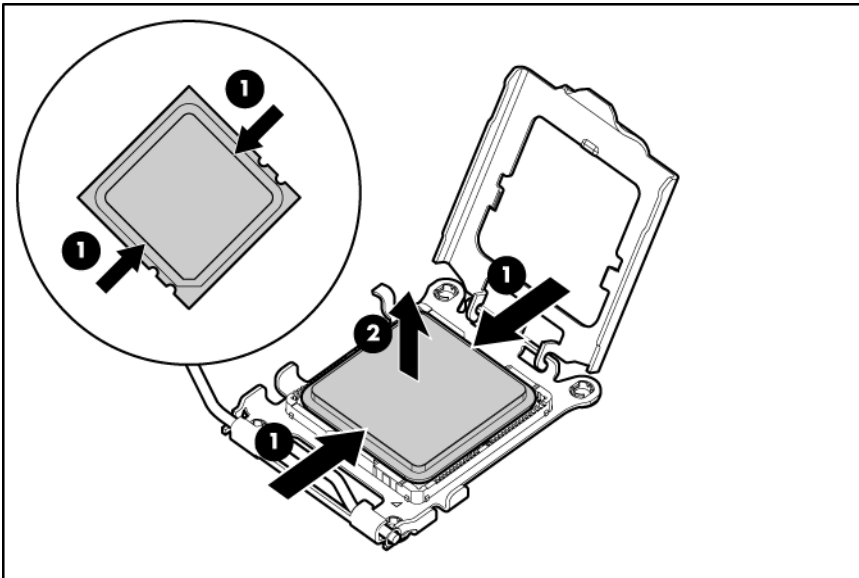

IMPORTANT: Be sure the replacement processor remains inside the processor installation tool.

7. If the processor has separated from the installation tool, carefully re-insert the processor in the tool.

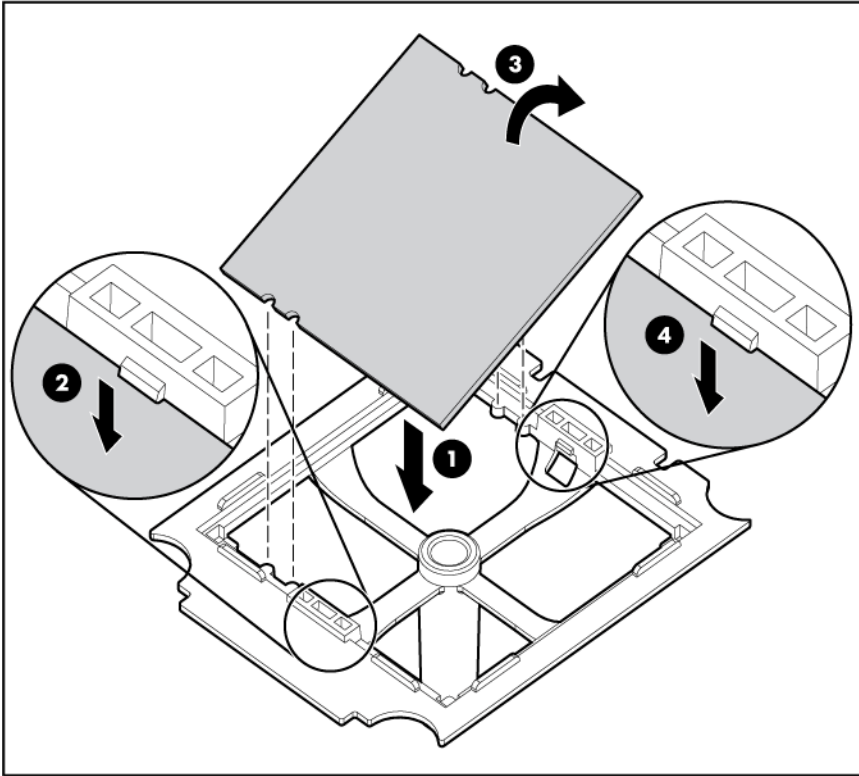

8. Align the processor installation tool with the socket and install the spare processor.

 **CAUTION:** The processor is designed to fit one way into the socket. Use the alignment guides on the processor and socket to properly align the processor with the socket.

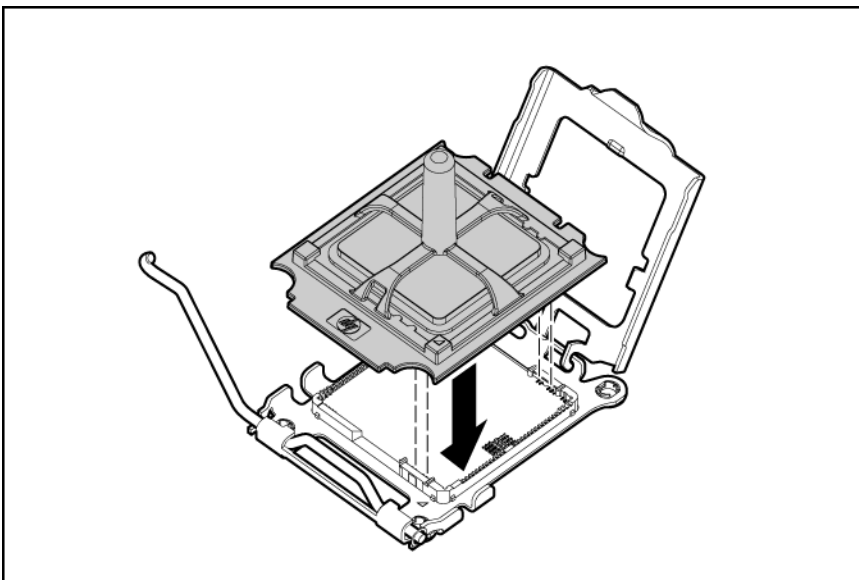

9. Press down firmly until the processor installation tool clicks and separates from the processor, and then remove the processor installation tool.

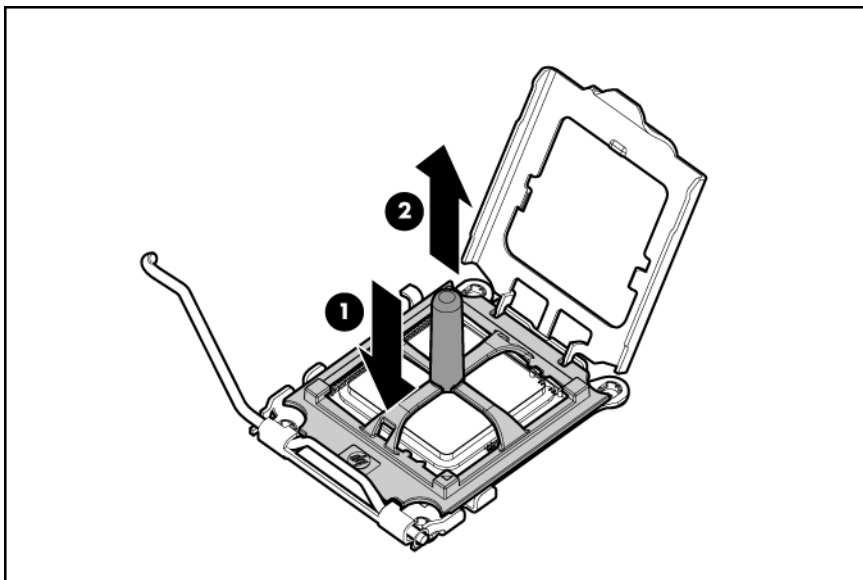

10. Close the processor retaining latch and the processor socket retaining bracket.

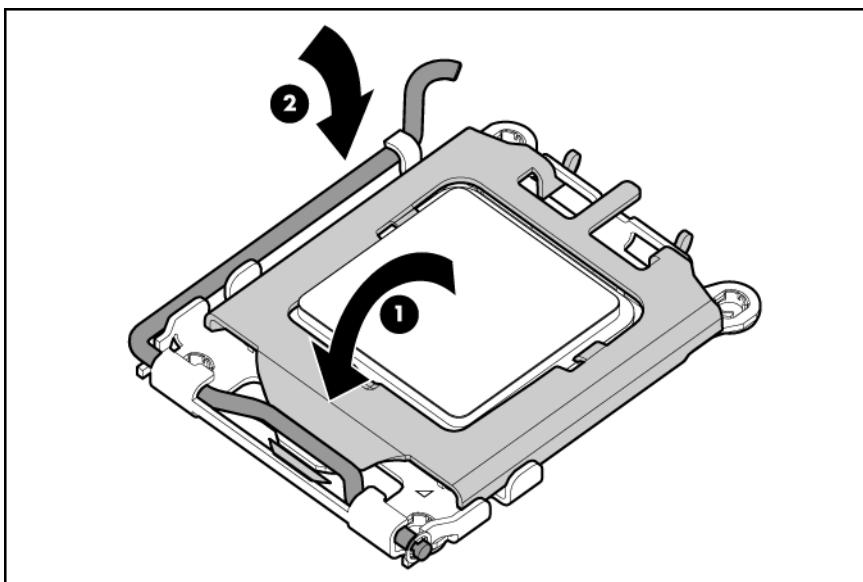

11. Clean the old thermal grease from the heatsink with the alcohol swab. Allow the alcohol to evaporate before continuing.

12. Apply all the grease to the top of the processor in one of the following patterns to ensure even distribution.

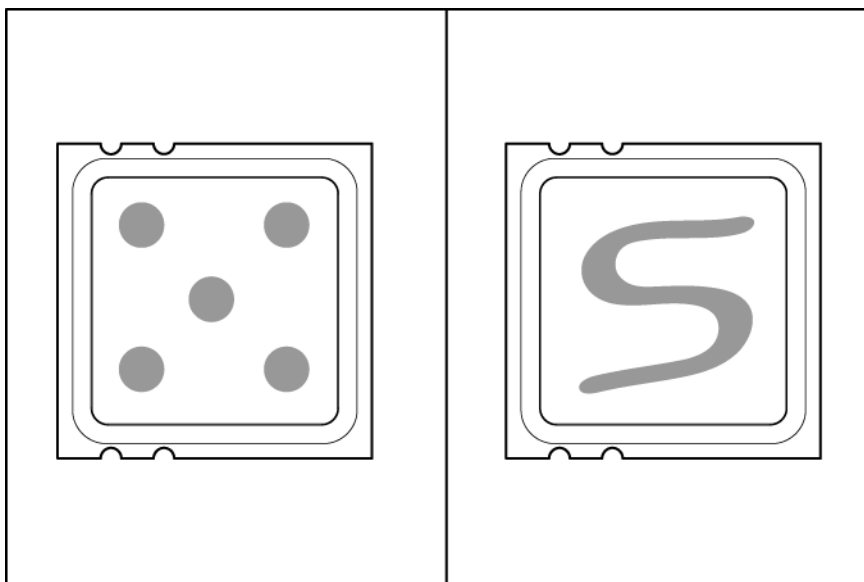

13. Install the heatsink.

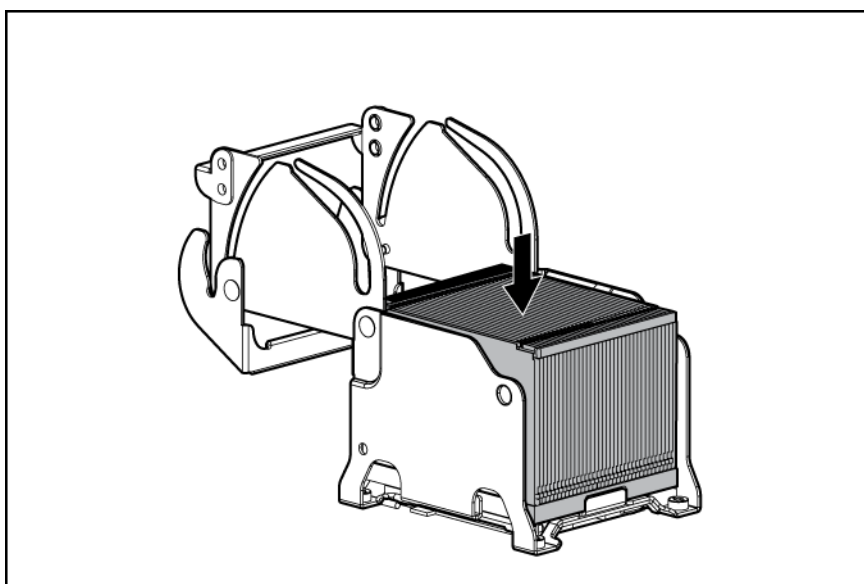

14. Close the heatsink retaining bracket.

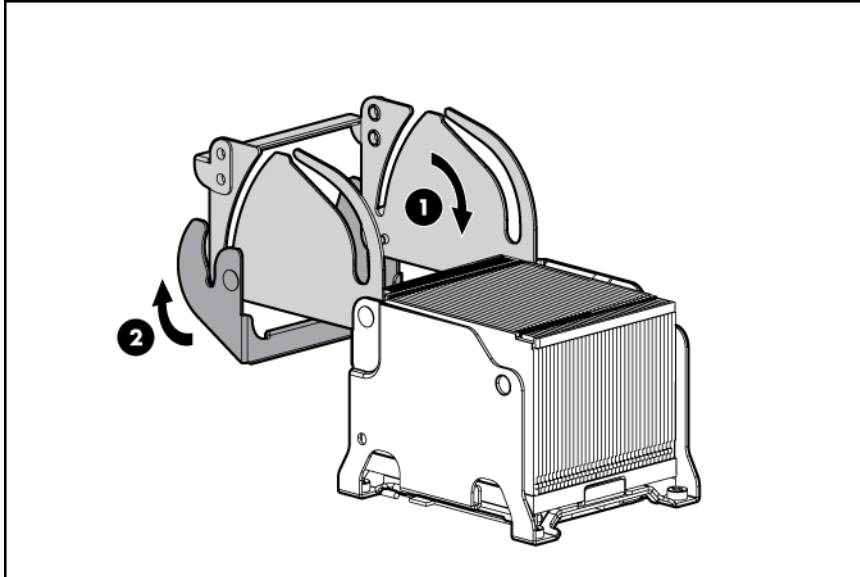

15. Close the processor memory module cover.
16. Install the fans.
17. Install the processor memory module into the server.
18. Power up the server.

PPM

Server PPMs provide the proper power to each processor. Each PPM must be installed in the slot adjacent to its processor.



CAUTION: Processor and PPM sockets 1 and 2 must be populated at all times or the server will not function properly.



IMPORTANT: Always install a PPM when you install a processor. The system fails to boot if the PPM is missing.

To remove a PPM:

1. Power down the server (on page 25).



WARNING: Use caution when installing the processor memory module or removing the processor memory module; when fully populated, it can weigh up to 13.6 kg (30 lb).

2. Remove the processor memory module, and open the cover ("Removing the processor memory module" on page 28).

3. Remove the PPM.

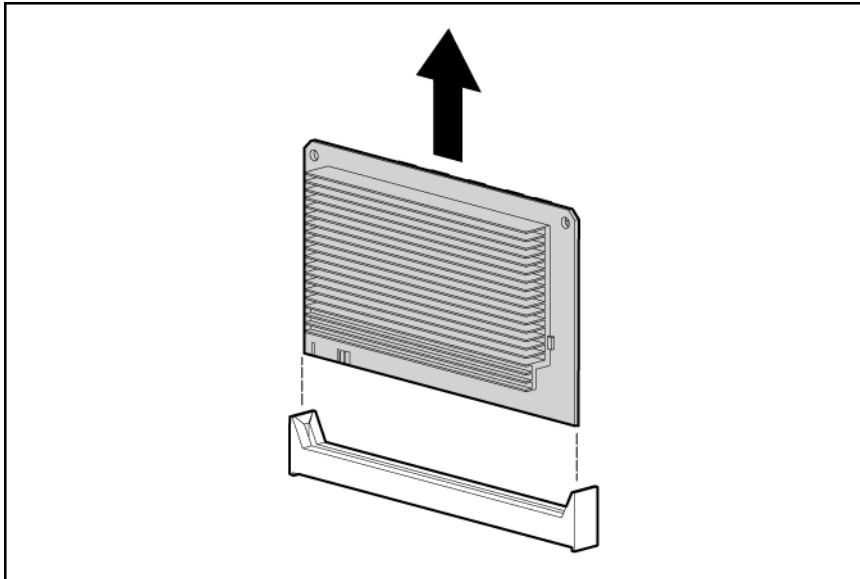

NOTE: The appearance of compatible PPMs may vary.

To replace the component, reverse the removal procedure.

NOTE: The PPM is keyed and the key must be aligned when installed.

DIMMs

1. Power down the server (on page 25).
2. Remove the processor memory module, and open the cover ("Removing the processor memory module" on page 28).
3. Open the DIMM slot latches.

4. Remove the DIMM ("DIMMs" on page 41).

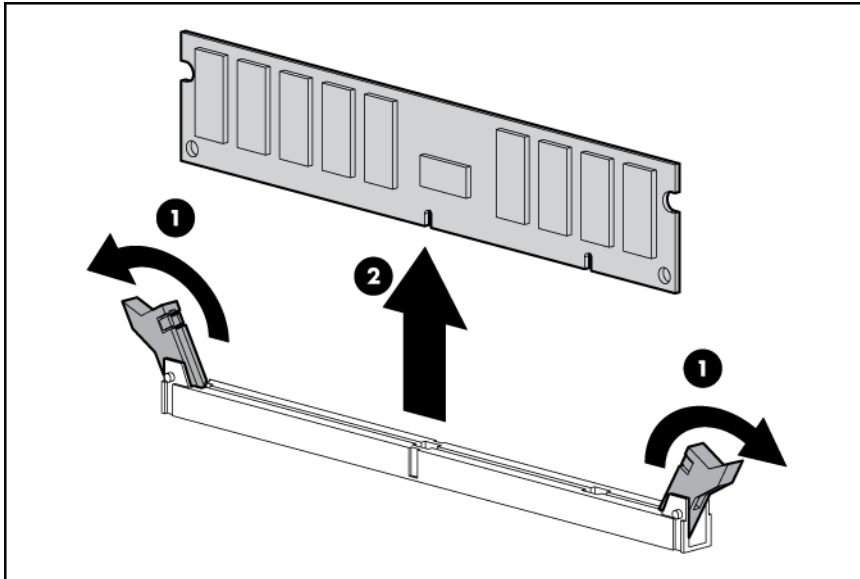

To replace the component, reverse the removal procedure.

Processor memory module

To replace the processor memory module:

1. Power down the server (on page 25).

⚠ WARNING: Use caution when installing the processor memory module or removing the processor memory module; when fully populated, it can weigh up to 13.6 kg (30 lb).

2. Remove the processor memory module, and open the cover ("Removing the processor memory module" on page 28).
3. Remove each processor ("Processors" on page 34), and install it in the same location in the new processor memory module.

📝 IMPORTANT: Be sure to install the processors in same location in the new processor memory module. For example, the processor from socket 1 must be installed in socket 1 of the new processor memory module. See the processor migration instructions that ship with the processor memory module for more information.

4. Remove each PPM ("PPM" on page 40), and install it in the same location in the new processor memory module.
5. Remove each DIMM ("DIMMs" on page 41) and install it in the same location in the new processor memory module.

📝 IMPORTANT: Be sure to install DIMMs in the same banks on the spare processor memory module. For example, the DIMM from slot 1A must be installed in slot 1A in the new processor memory module.

6. Close the processor memory module cover.
7. Install the fans.
8. Install the processor memory module into the server.

9. Power up the server.



IMPORTANT: To prevent damage to the processor socket pins during shipment, install the processor socket covers before the defective processor memory module is shipped to HP.

SAS or SATA hard drives

△ **CAUTION:** Always power down the server if the boot partition resides on the drive you are replacing or if you are replacing the only drive in the server.

△ **CAUTION:** To prevent improper cooling and thermal damage, do not operate the server unless all bays are populated with either a component or a blank.

1. Determine the status of the hard drive from the hot-plug hard drive LEDs ("SAS and SATA hard drive LED combinations" on page 71, "SAS and SATA hard drive LEDs" on page 70).
2. Back up all data on the hard drive.
3. Remove the hard drive.

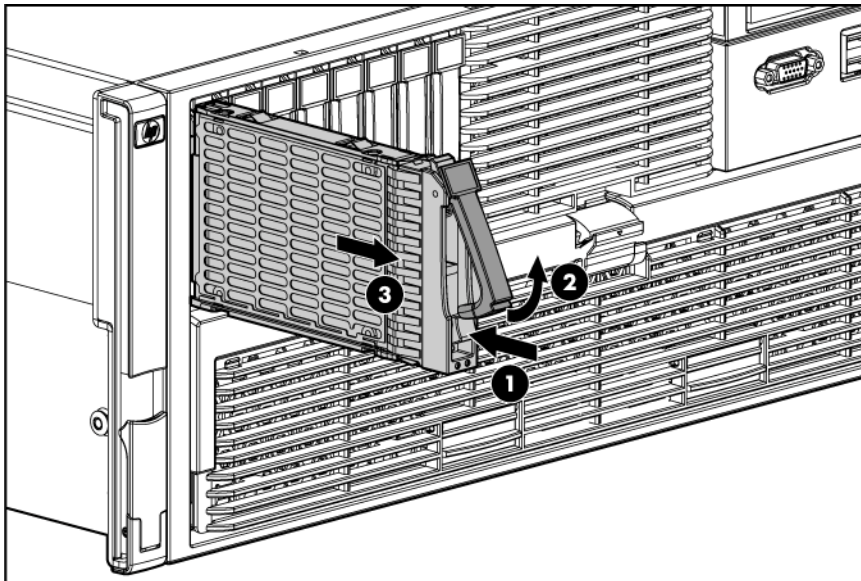

To replace the component, reverse the removal procedure.

Diskette, DVD, CD-RW drive, or blank

1. Power down the server (on page 25).
2. Use the T-15 Torx screwdriver to eject the drive, and pull the drive out of the server.

NOTE: The T-15 Torx screwdriver is shipped with the server and can be located on the rear panel ("Rear panel components" on page 72).

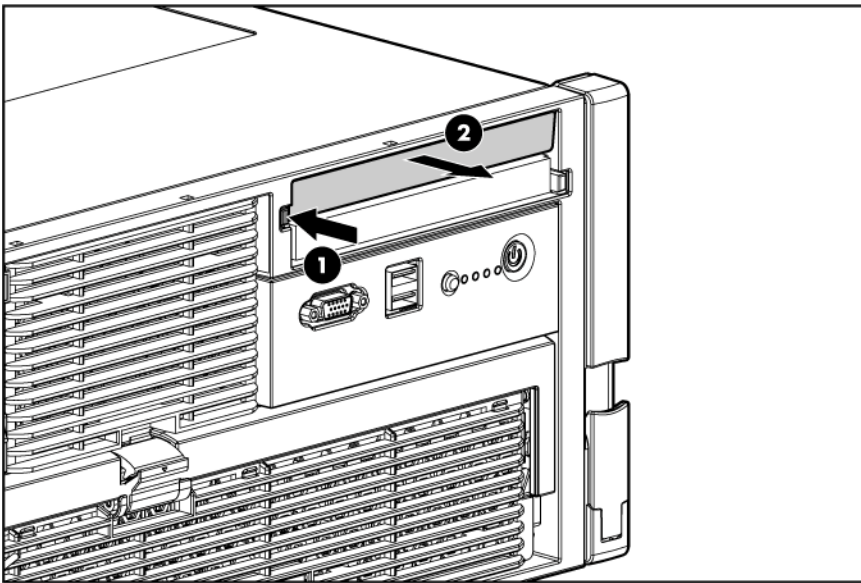

To replace the component, reverse the removal procedure.

Power supply blank

Press the handle and pull the power supply blank from the server.

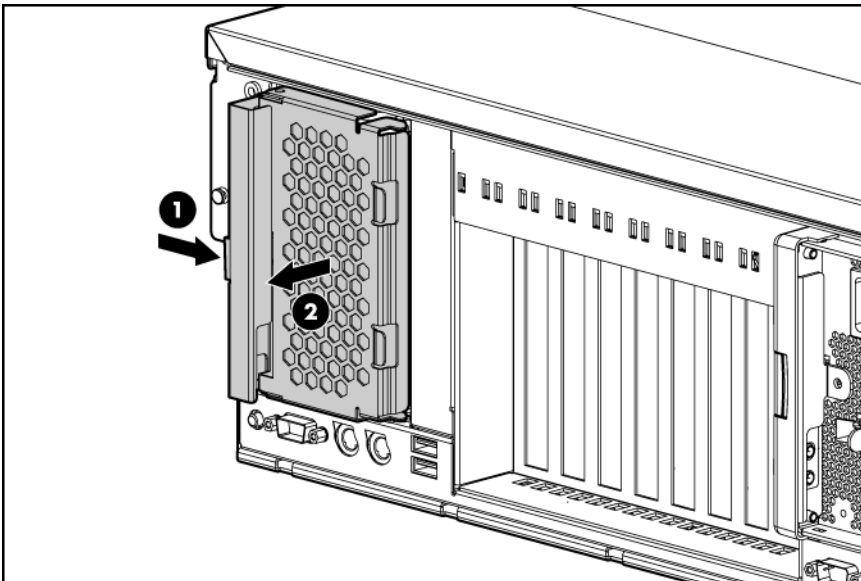

To replace the component, reverse the removal procedure.

Power supply



WARNING: To reduce the risk of electric shock, do not disassemble the power supply or attempt to repair it. Replace it only with the specified spare part.



CAUTION: If only one power supply is installed, do not remove the power supply unless the server has been powered down. Removing the only operational power supply will cause an

immediate power loss.

CAUTION: To prevent improper cooling and thermal damage, do not operate the server unless all bays are populated with either a component or a blank.

NOTE: Refer to the section "Power supply LEDs ("Hot-plug power supply LEDs" on page 73)" for information on the current status of the hot-plug power supply.

1. Disconnect the power cord from the power supply.
 2. Remove the power supply.
-

NOTE: To remove the primary hot-plug power supply, remove the shipping screw under the power supply handle. Use the T-15 Torx screwdriver ("Rear panel components" on page 72).

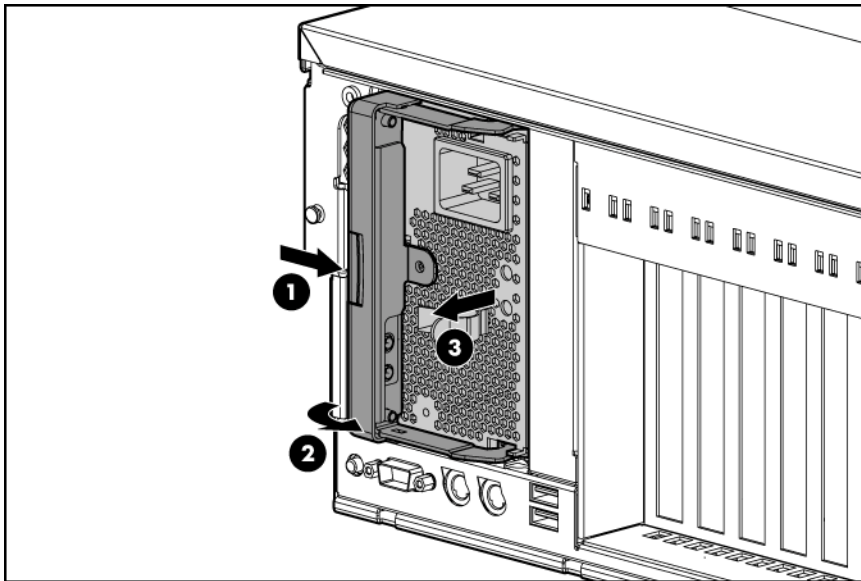

To replace the component, reverse the removal procedure.

Hot-plug fans

The server supports redundant hot-plug fans ("Fan locations" on page 80) in a 5+1 configuration to provide proper airflow to the server.

WARNING: To prevent personal injury from hazardous energy:

- Remove watches, rings, or other metal objects.
 - Use tools with insulated handles.
 - Do not place tools or metal parts on top of batteries.
-

To replace a hot-plug fan:

1. Extend the server from the rack ("Extending the server from the rack" on page 26).
2. Remove the access panel ("Removing the access panel" on page 27).
3. Identify the failed fan by locating an amber LED on top of the failed fan ("Hot-plug fan LEDs" on page 81) or on the Systems Insight Display ("Systems Insight Display LEDs" on page 77).

4. Remove the malfunctioning hot-plug fan from the server.



IMPORTANT: Remove and replace one fan at a time. If the system detects two fan failures, the server shuts down to avoid thermal damage.

5. Install a new hot-plug fan.

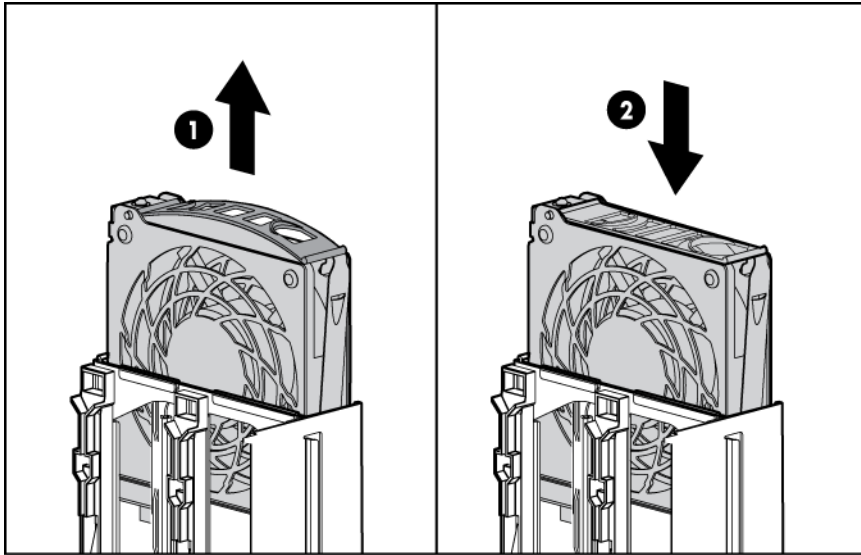

6. Observe the LED on each installed fan to be sure it is illuminated green ("Hot-plug fan LEDs" on page 81).

NOTE: If the front panel internal system health LED is not green after you install hot-plug fans, reseal the hot-plug fan or refer to the troubleshooting section.

7. Replace the access panel ("Removing the access panel" on page 27).
8. Slide the server into the rack.

Expansion slot covers



CAUTION: To prevent improper cooling and thermal damage, do not operate the server unless all expansion slots have either an expansion slot cover or an expansion board installed.

1. Power down the server (on page 25).
2. Extend the server from the rack ("Extending the server from the rack" on page 26).
3. Remove the access panel ("Removing the access panel" on page 27).

4. Open the latch, and remove the expansion slot cover.

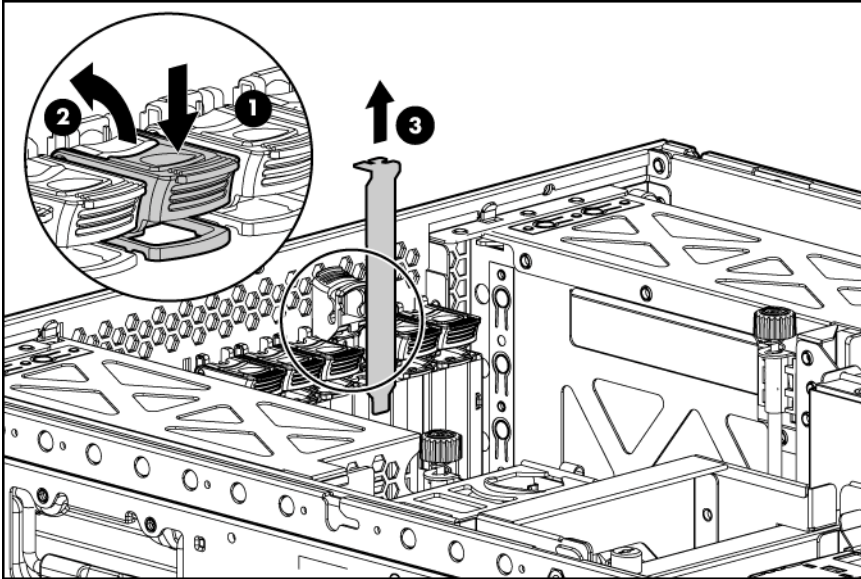

To replace the component, reverse the removal procedure.

Expansion boards

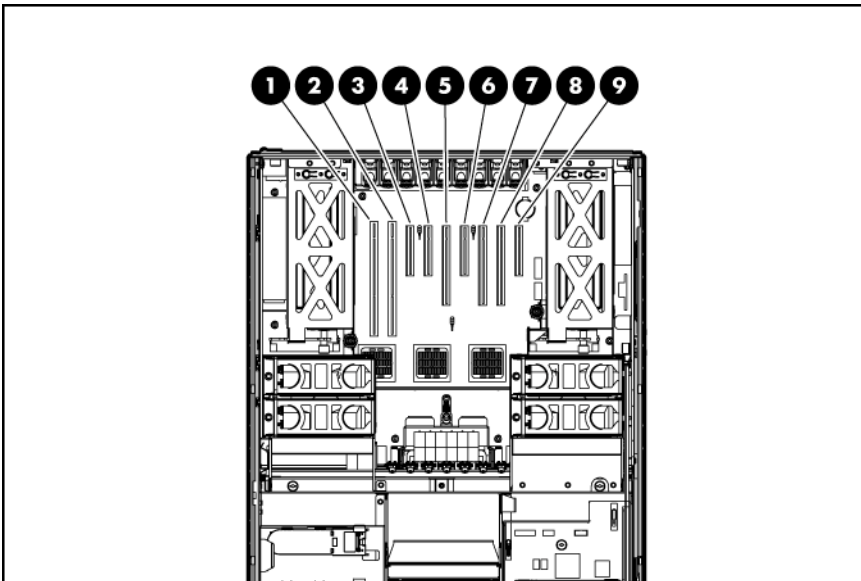

Slot	Description
1	PCI-X non-hot-plug expansion slot, 64-bit/100-MHz (half-length)
2	PCI-X non-hot-plug expansion slot, 64-bit/100-MHz (full-length)
3	PCI Express x4 non-hot-plug expansion slot (full-length)
4	PCI Express x4 non-hot-plug expansion slot (full-length)
5	PCI Express x8 non-hot-plug expansion slot (full-length)
6	PCI Express x4 non-hot-plug expansion slot (full-length)

Slot	Description
7	PCI Express x8 non-hot-plug expansion slot (full-length)
8	PCI Express x8 non-hot-plug expansion slot (full-length)
9	PCI Express x4 non-hot-plug expansion slot (half-length)

To remove a non-hot-plug expansion board:

1. Power down the server (on page 25).
2. Extend or remove the server from the rack ("Remove the server from the rack" on page 27, "Extending the server from the rack" on page 26).
3. Remove the access panel ("Removing the access panel" on page 27).
4. Disconnect any internal or external cables attached to the expansion board.
5. Open the latch.
6. Unlock the retaining clip (for full-length expansion boards).
7. Remove the board from the server.

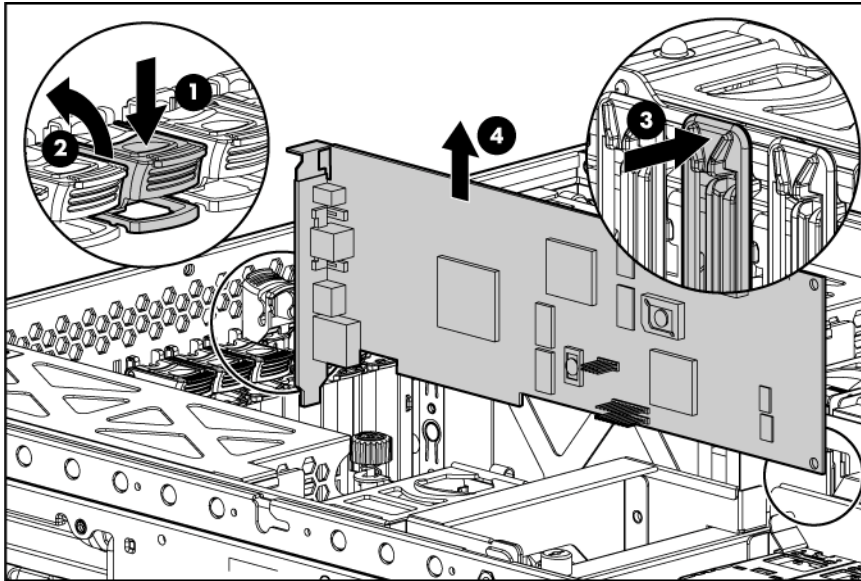

To replace the component, reverse the removal procedure.

SAS backplane

1. Power down the server (on page 25).
2. Remove all hard drives ("SAS or SATA hard drives" on page 43).
3. Extend or remove the server from the rack ("Remove the server from the rack" on page 27, "Extending the server from the rack" on page 26).
4. Remove the access panel ("Removing the access panel" on page 27).
5. Disconnect all cables from the SAS backplane.
6. Slide the bracket to the front of the server.

7. Lift the backplane, slide the board over the anchoring pins, and lift the board out of the server.

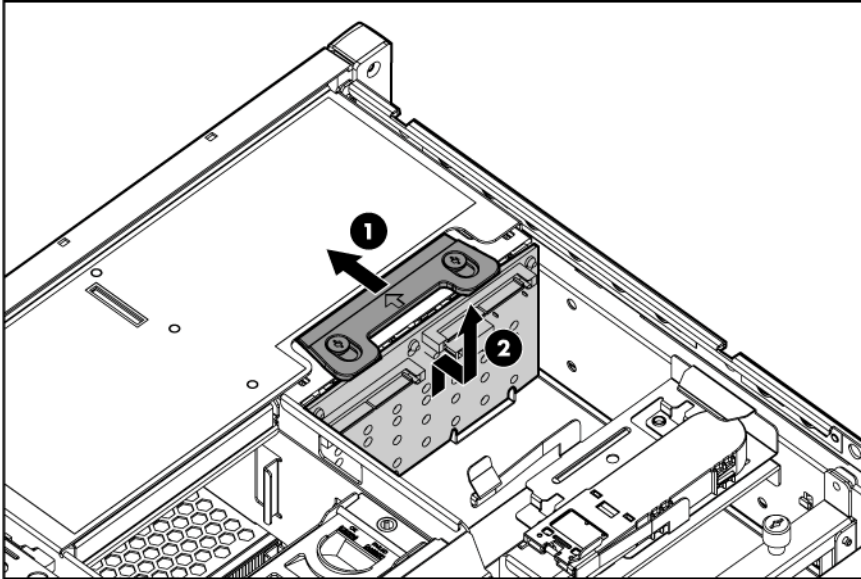

To replace the component, reverse the removal procedure.

Pass-through board

1. Power down the server (on page 25).
2. Extend the server from the rack ("Extending the server from the rack" on page 26).
3. Remove the access panel ("Removing the access panel" on page 27).
4. Loosen the thumbscrews and lift the pass-through board out of the server.

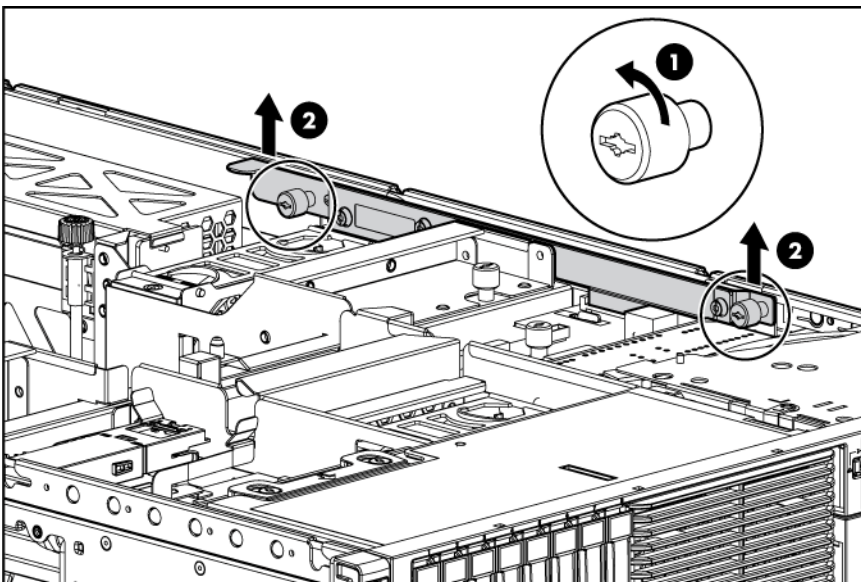

To replace the component, reverse the removal procedure.

Media board

1. Power down the server (on page 25).

2. Remove all media drives and media drive blanks ("Diskette, DVD, CD-RW drive, or blank" on page 43).
3. Extend the server from the rack ("Extending the server from the rack" on page 26).
4. Remove the access panel ("Removing the access panel" on page 27).
5. Remove the pass-through board ("Pass-through board" on page 49).
6. Disconnect all cabling from the media board.
7. Loosen the thumbscrew and slide the media board toward the front of the server.
8. Tilting the rear of the media board, lift the media board out of the server.

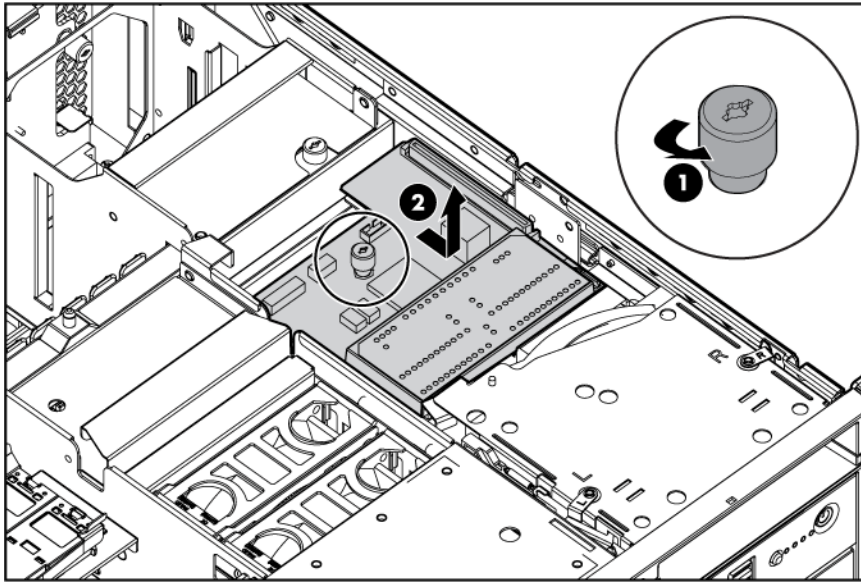

To replace the component, reverse the removal procedure.

Battery-backed write cache procedures

Two types of procedures are provided for the BBWC option:

- Removal and replacement of failed components:
 - Removing the cache module (on page 50)
 - Removing the battery pack ("BBWC battery pack" on page 52)
- Recovery of cached data from a failed server ("Recovering data from the battery-backed write cache" on page 53)

△ **CAUTION:** Do not detach the cable that connects the battery pack to the cache module. Detaching the cable causes any unsaved data in the cache module to be lost.

Removing the cache module

△ **CAUTION:** After the server is powered down, wait 15 seconds and then check the amber LED before unplugging the cable from the cache module. If the amber LED blinks after 15 seconds, do not remove the cable from the cache module. The cache module is backing up data, and data is lost if the cable is detached.

1. Power down the server (on page 25).
2. Extend the server from the rack ("Extending the server from the rack" on page 26).
3. Remove the access panel ("Removing the access panel" on page 27).

CAUTION: Disconnect the cable from the cache module only if the battery pack is not being used to recover data from the server or transfer data to another server.

4. If the existing cache is connected to a battery, observe the BBWC Status LED ("Battery pack LEDs" on page 79).
 - o If the LED is blinking every 2 seconds, data is still trapped in the cache. Restore system power, and repeat the previous steps.
 - o If the LED is not lit, disconnect the battery cable from the cache.

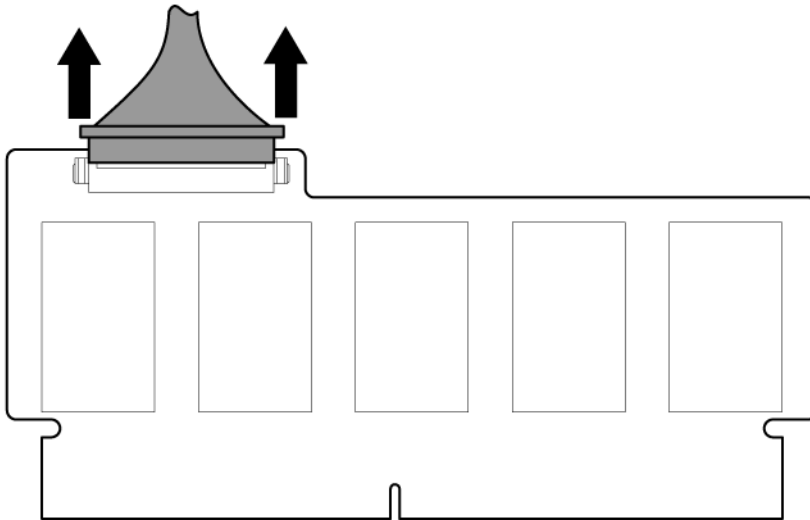

5. Remove the controller.

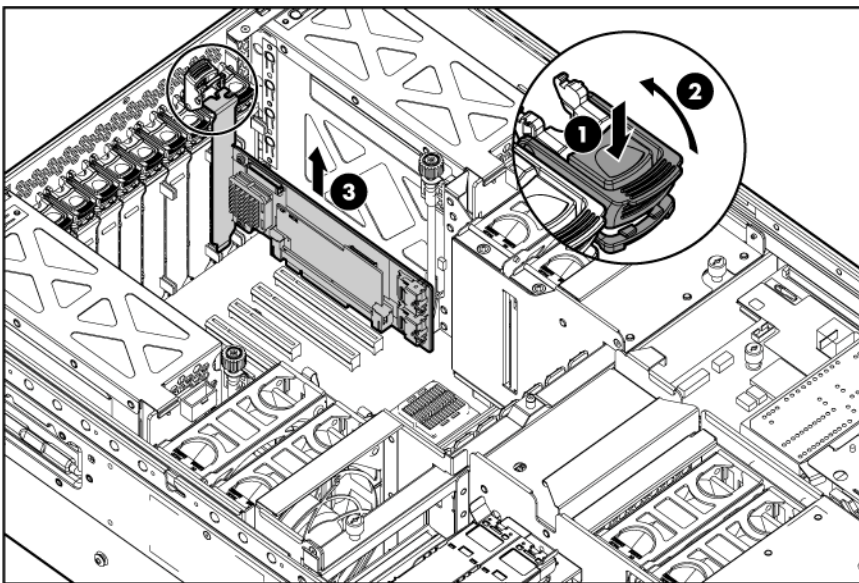

6. Remove the cache module from the controller.

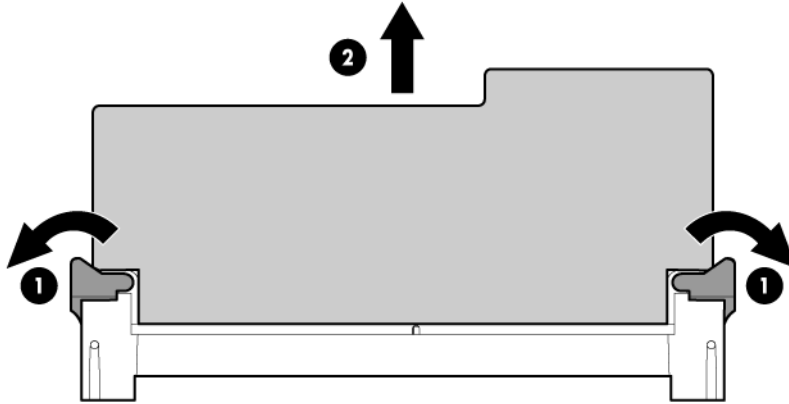

To replace the component, reverse the removal procedure.

BBWC battery pack

1. Power down the server (on page 25).
2. Extend or remove the server from the rack ("Remove the server from the rack" on page 27, "Extending the server from the rack" on page 26).
3. Remove the access panel ("Removing the access panel" on page 27).

△ **CAUTION:** To prevent a server malfunction or damage to the equipment, do not add or remove the battery pack while an array capacity expansion, RAID level migration, or stripe size migration is in progress.

△ **CAUTION:** After the server is powered down, wait 15 seconds and then check the amber LED before unplugging the cable from the cache module. If the amber LED blinks after 15 seconds, do not remove the cable from the cache module. The cache module is backing up data, and data is lost if the cable is detached.

4. Remove the BBWC battery pack ("BBWC battery pack" on page 52).

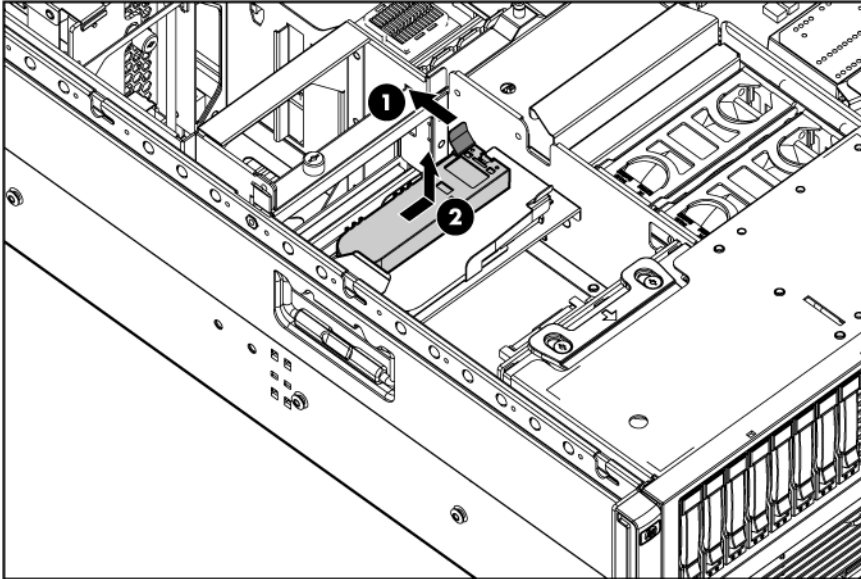

5. Disconnect the cable from the cache module only if the battery pack is not being used to recover data from the server or transfer data to another server.

CAUTION: Do not detach the cable that connects the battery pack to the cache module. Detaching the cable causes any unsaved data in the cache module to be lost.

To replace the component, reverse the removal procedure.

IMPORTANT: The battery pack might have a low charge when installed. In this case, a POST error message is displayed when the server is powered up, indicating that the battery pack is temporarily disabled. No action is necessary on your part. The internal circuitry automatically recharges the batteries and enables the battery pack. This process might take up to four hours. During this time, the cache module functions properly, but without the performance advantage of the battery pack.

NOTE: The data protection and the time limit also apply if a power outage occurs. When power is restored to the system, an initialization process writes the preserved data to the hard drives.

Recovering data from the battery-backed write cache

If the server fails, you can recover any data temporarily trapped in the BBWC by using the following procedure.

CAUTION: Before starting this procedure, read the information about protecting against electrostatic discharge ("Preventing electrostatic discharge" on page 24).

1. Perform one of the following:
 - o Set up a recovery server station using an identical server model. Do not install any internal drives or BBWC in this server. (This is the preferred option.)
 - o Find a server that has enough empty drive bays to accommodate all the drives from the failed server and that meets all the other requirements for drive and array migration.

2. Power down the failed server ("Power down the server" on page 25). If any data is trapped in the cache module, an amber LED on the module blinks every 15 seconds.



CAUTION: Do not detach the cable that connects the battery pack to the cache module. Detaching the cable causes any unsaved data in the cache module to be lost.

3. Transfer the hard drives from the failed server to the recovery server station.
4. Remove the BBWC [cache module ("Removing the cache module" on page 50) and battery pack ("BBWC battery pack" on page 52)] from the failed server.
5. Perform one of the following:
 - o Install the BBWC into an empty BBWC DIMM socket on the system board of the recovery server.
 - o Install the BBWC into an empty BBWC DIMM socket on any Smart Array Controller in the recovery server.
6. Power up the recovery server. A 1759 POST message is displayed, stating that valid data was flushed from the cache. This data is now stored on the drives in the recovery server. You can now transfer the drives (and controller, if one was used) to another server.

System cage

Installing or accessing some options or components in the server might require removing the system cage. See the instructions for each individual option to determine if removing the system cage is necessary.

To remove the system cage:

1. Power down the server (on page 25).
2. Remove the server from the rack (on page 27).
3. Remove the access panel ("Removing the access panel" on page 27).
4. Remove all hot-plug power supplies ("Power supply" on page 44).
5. Remove fans 3 through 6 installed in front of the power supply cages ("Fan locations" on page 80).
6. Remove all expansion boards ("Expansion boards" on page 47).
7. Remove all expansion slot covers ("Expansion slot covers" on page 46).
8. Remove the pass-through board ("Pass-through board" on page 49).
9. Loosen the thumbscrews, and lift the system cage from the server.

NOTE: The T-15 Torx screwdriver can be used to loosen the thumbscrews. The T-15 Torx screwdriver is shipped with the server and can be located on the rear panel ("Rear panel components" on page 72).

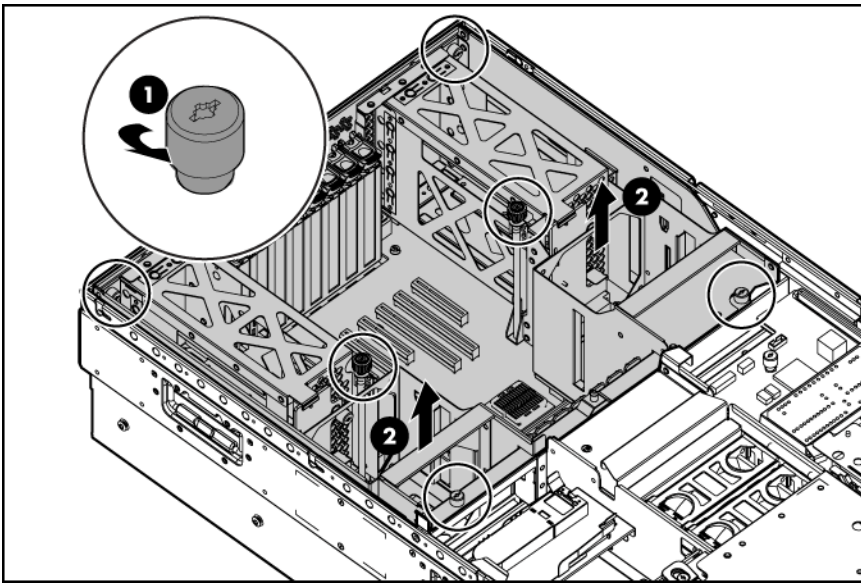

To replace the component, reverse the removal procedure.

Power supply backplane

1. Power down the server (on page 25).
2. Remove the server from the rack (on page 27).
3. Remove the access panel ("Removing the access panel" on page 27).
4. Remove all hot-plug power supplies ("Power supply" on page 44).
5. Remove fans 3 through 6 installed in front of the power supply cages ("Fan locations" on page 80).
6. Remove all expansion boards ("Expansion boards" on page 47).
7. Remove all expansion slot covers ("Expansion slot covers" on page 46).
8. Remove the pass-through board ("Pass-through board" on page 49).
9. Remove the system cage ("System cage" on page 54).
10. Turn the system cage over and place it on a level surface.

11. Loosen the thumbscrew and remove the backplane.

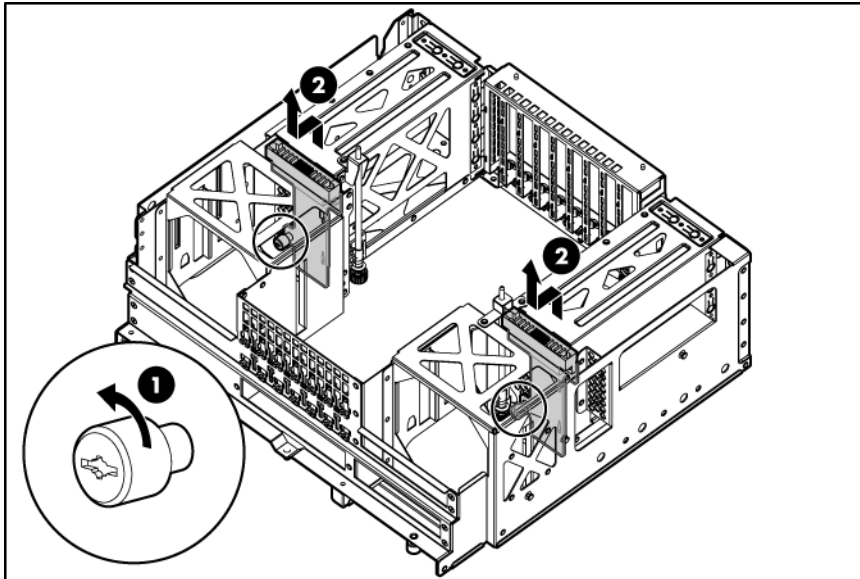

System board

- △ **CAUTION:** Before starting this procedure, read the information about protecting against electrostatic discharge ("Preventing electrostatic discharge" on page 24).
- △ **CAUTION:** Only authorized technicians trained by HP should attempt to remove the system board. If you believe the system board requires replacement, contact HP Technical Support ("HP contact information" on page 87) before proceeding.
- 📄 **IMPORTANT:** HP recommends troubleshooting the system using port 85 codes before replacing the system board. Refer to "Troubleshooting the system using port 85 codes (on page 63)" for a list of codes and troubleshooting procedures.

1. Power down the server (on page 25).
2. Remove the server from the rack (on page 27).
3. Remove the access panel ("Removing the access panel" on page 27).
4. Remove fans 3 through 6 installed in front of the power supply cages ("Fan locations" on page 80).
5. Remove all expansion boards ("Expansion boards" on page 47).
6. Remove all expansion slot covers ("Expansion slot covers" on page 46).
7. Remove the pass-through board ("Pass-through board" on page 49).
8. Remove all power supplies ("Power supply" on page 44).
9. Remove the system cage ("System cage" on page 54).
10. Disconnect the SAS power cable from the system board.
11. Unlock the latch and open the lever.

12. Slide the system board out through the back of the server.

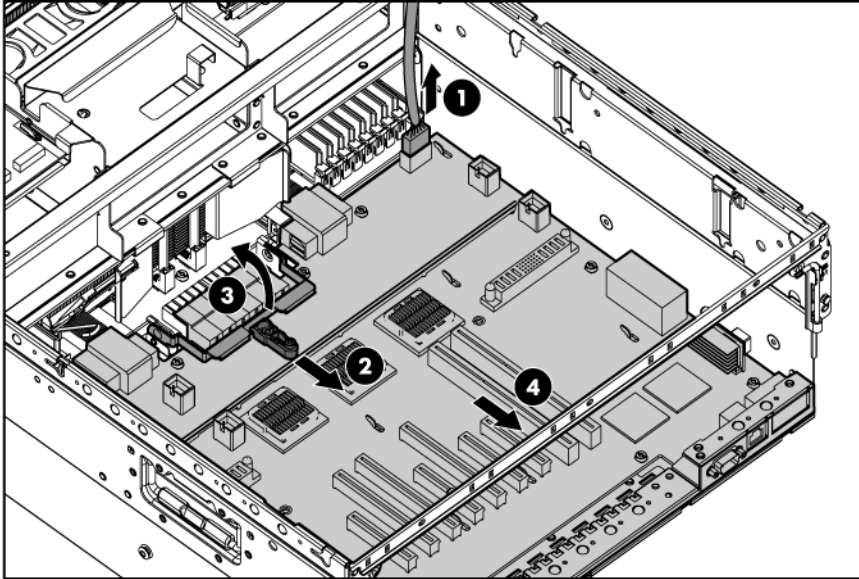

IMPORTANT: If replacing the system board or clearing NVRAM, you must re-enter the server serial number through RBSU ("Re-entering the server serial number and product ID" on page 57).

To replace the component, reverse the removal procedure.

Re-entering the server serial number and product ID

After you replace the system board, you must re-enter the server serial number and the product ID.

1. During the server startup sequence, press the **F9** key to access RBSU.
2. Select the **Advanced Options** menu.
3. Select **Serial Number**. The following warning is displayed:
Warning: The serial number should ONLY be modified by qualified service personnel. This value should always match the serial number located on the chassis.
4. Press the **Enter** key to clear the warning.
5. Enter the serial number.
6. Select **Product ID**. The following warning is displayed:
Warning: The Product ID should ONLY be modified by qualified service personnel. This value should always match the Product ID located on the chassis.
7. Enter the product ID and press the **Enter** key.
8. Press the **Escape** key to close the menu.
9. Press the **Escape** key to exit RBSU.
10. Press the **F10** key to confirm exiting RBSU. The server will automatically reboot.

System battery

-
- ⚠ **CAUTION:** Before starting this procedure, read the information about protecting against electrostatic discharge ("Preventing electrostatic discharge" on page 24).
-

If the server no longer automatically displays the correct date and time, you may need to replace the battery that provides power to the real-time clock. Under normal use, battery life is 5 to 10 years.

- ⚠ **WARNING:** The computer contains an internal lithium manganese dioxide, a vanadium pentoxide, or an alkaline battery pack. A risk of fire and burns exists if the battery pack is not properly handled. To reduce the risk of personal injury:
- Do not attempt to recharge the battery.
 - Do not expose the battery to temperatures higher than 60°C (140°F).
 - Do not disassemble, crush, puncture, short external contacts, or dispose of in fire or water.
 - Replace only with the spare designated for this product.
-

To remove the battery:

1. Power down the server (on page 25).
2. Extend or remove the server from the rack ("Remove the server from the rack" on page 27, "Extending the server from the rack" on page 26).
3. Remove the access panel ("Removing the access panel" on page 27).
4. Locate the battery ("Internal components" on page 74). It might be necessary to remove expansion boards (on page 47) from and around slot 9 to access the battery.
5. Remove the battery.

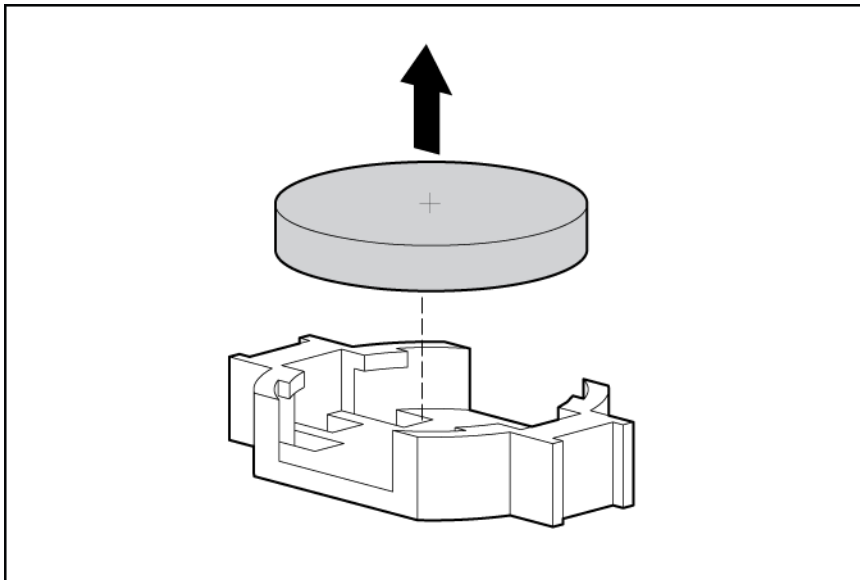

To replace the component, reverse the removal procedure.

Run the RBSU to configure the server after replacing the battery. See the *HP ROM-Based Setup Utility User Guide* on the Documentation CD for more detailed information.

Diagnostic tools

SmartStart software

SmartStart is a collection of software that optimizes single-server setup, providing a simple and consistent way to deploy server configuration. SmartStart has been tested on many ProLiant server products, resulting in proven, reliable configurations.

SmartStart assists the deployment process by performing a wide range of configuration activities, including:

- Configuring hardware using embedded configuration utilities, such as RBSU and ORCA
- Preparing the system for installing "off-the-shelf" versions of leading operating system software
- Installing optimized server drivers, management agents, and utilities automatically with every assisted installation
- Testing server hardware using the Insight Diagnostics Utility ("HP Insight Diagnostics" on page 63)
- Installing software drivers directly from the CD. With systems that have internet connection, the SmartStart Autorun Menu provides access to a complete list of ProLiant system software.
- Enabling access to the Array Configuration Utility, Array Diagnostic Utility, and Erase Utility

SmartStart is included in the HP ProLiant Essentials Foundation Pack. For more information about SmartStart software, refer to the HP ProLiant Essentials Foundation Pack or the HP website (<http://h18013.www1.hp.com/products/servers/management/smartstart/index.html>).

SmartStart Scripting Toolkit

The SmartStart Scripting Toolkit is a server deployment product that delivers an unattended automated installation for high-volume server deployments. The SmartStart Scripting Toolkit is designed to support ProLiant BL, ML, and DL servers. The toolkit includes a modular set of utilities and important documentation that describes how to apply these new tools to build an automated server deployment process.

Using SmartStart technology, the Scripting Toolkit provides a flexible way to create standard server configuration scripts. These scripts are used to automate many of the manual steps in the server configuration process. This automated server configuration process cuts time from each server deployed, making it possible to scale server deployments to high volumes in a rapid manner.

For more information, and to download the SmartStart Scripting Toolkit, refer to the HP website (<http://www.hp.com/servers/sstoolkit>).

HP Insight Remote Support software

HP Insight Remote Support software delivers secure remote support for your HP Servers and Storage, 24 X 7, so you can spend less time solving problems and more time focused on your business. You can have your systems remotely monitored for hardware failure using secure technology that has been proven at

thousands of companies around the world. In many cases, you can avoid problems before they occur. There are two HP Insight Remote Support solutions:

- For small and midsize environments: HP Insight Remote Support Standard provides basic remote monitoring, notification/advisories and service dispatch. It is optimized for environments with 1 to 50 servers and can be installed on a shared HP ProLiant Windows application server. The software supports HP EVA storage devices, HP ProLiant, BladeSystems, HP Integrity and HP 9000 servers running Microsoft Windows, Red Hat Enterprise Linux, Novell SUSE and Novell Netware. Download from the HP website (<http://h20392.www2.hp.com/portal/swdepot/displayProductInfo.do?productNumber=RSSWMBA SE>).
- For midsize and large environments: HP Insight Remote Support Pack (formerly Service Essentials Remote Support Pack) is targeted for larger environments and is integrated with HP Systems Insight Manager (SIM). It provides comprehensive remote monitoring, notification/advisories, dispatch and proactive service support for nearly all HP servers, storage, network and SAN environments, plus selected Dell and IBM Windows servers that have a support obligation with HP. It also enables HP to deliver higher levels of proactive support in line with HP Mission Critical Services support agreements. Download from the HP website (<http://h20392.www2.hp.com/portal/swdepot/displayProductInfo.do?productNumber=ISDVD>).

Both HP Insight Remote Support solutions are available at no additional cost to customers with a valid warranty on HP technology, an HP Care Pack Service or HP contractual support agreement.

For more information, see the HP website (<http://www.hp.com/go/insightremotesupport>).

Option ROM Configuration for Arrays

Before installing an operating system, you can use the ORCA utility to create the first logical drive, assign RAID levels, and establish online spare configurations.

The utility also provides support for the following functions:

- Reconfiguring one or more logical drives
- Viewing the current logical drive configuration
- Deleting a logical drive configuration
- Setting the controller to be the boot controller

If you do not use the utility, ORCA will default to the standard configuration.

For more information regarding array controller configuration, refer to the controller user guide.

For more information regarding the default configurations that ORCA uses, refer to the *HP ROM-Based Setup Utility User Guide* on the Documentation CD.

HP ROM-Based Setup Utility

RBSU is a configuration utility embedded in ProLiant servers that performs a wide range of configuration activities that can include the following:

- Configuring system devices and installed options
- Enabling and disabling system features
- Displaying system information

- Selecting the primary boot controller
- Configuring memory options
- Language selection

For more information on RBSU, see the *HP ROM-Based Setup Utility User Guide* on the Documentation CD or the HP website (<http://www.hp.com/support/smartstart/documentation>).

ROMPaq utility

The ROMPaq utility enables you to upgrade the system firmware (BIOS). To upgrade the firmware, insert a ROMPaq diskette into the diskette drive or ROMPaq USB Key into an available USB port and boot the system. Online versions of the ROMPaq utility are also available for updating the system firmware.

The ROMPaq utility checks the system and provides a choice (if more than one exists) of available firmware revisions.

For more information about the ROMPaq utility, see the HP website (<http://www.hp.com/go/support>).

System Online ROM flash component utility

The Online ROM Flash Component Utility enables system administrators to efficiently upgrade system or controller ROM images across a wide range of servers and array controllers. This tool has the following features:

- Works offline and online
- Supports Microsoft® Windows NT®, Windows® 2000, Windows Server® 2003, Novell Netware, and Linux operating systems



IMPORTANT: This utility supports operating systems that may not be supported by the server. For operating systems supported by the server, see the HP website (<http://www.hp.com/support>).

- Integrates with other software maintenance, deployment, and operating system tools
- Automatically checks for hardware, firmware, and operating system dependencies, and installs only the correct ROM upgrades required by each target server

To download the tool and for more information, see the HP website (<http://www.hp.com/support>).

Integrated Management Log

The IML records hundreds of events and stores them in an easy-to-view form. The IML timestamps each event with 1-minute granularity.

You can view recorded events in the IML in several ways, including the following:

- From within HP SIM ("HP Systems Insight Manager" on page 62)
- From within Survey Utility
- From within operating system-specific IML viewers
 - For NetWare: IML Viewer
 - For Windows®: IML Viewer

- For Linux: IML Viewer Application
- From within the iLO 2 user interface
- From within HP Insight Diagnostics (on page 63)

For more information, refer to the Management CD in the HP ProLiant Essentials Foundation Pack.

Integrated Lights-Out 2 technology

The iLO 2 subsystem is a standard component of selected ProLiant servers that provides server health and remote server manageability. The iLO 2 subsystem includes an intelligent microprocessor, secure memory, and a dedicated network interface. This design makes iLO 2 independent of the host server and its operating system. The iLO 2 subsystem provides remote access to any authorized network client, sends alerts, and provides other server management functions.

Using iLO 2, you can:

- Remotely power up, power down, or reboot the host server.
- Send alerts from iLO 2 regardless of the state of the host server.
- Access advanced troubleshooting features through the iLO 2 interface.
- Diagnose iLO 2 using HP SIM through a web browser and SNMP alerting.

For more information about iLO 2 features (which may require an iLO Advanced Pack or iLO Advanced for BladeSystem license), see the iLO 2 documentation on the Documentation CD or on the HP website (<http://www.hp.com/servers/lights-out>).

Automatic Server Recovery

ASR is a feature that causes the system to restart when a catastrophic operating system error occurs, such as a blue screen, ABEND, or panic. A system fail-safe timer, the ASR timer, starts when the System Management driver, also known as the Health Driver, is loaded. When the operating system is functioning properly, the system periodically resets the timer. However, when the operating system fails, the timer expires and restarts the server.

ASR increases server availability by restarting the server within a specified time after a system hang or shutdown. At the same time, the HP SIM console notifies you by sending a message to a designated pager number that ASR has restarted the system. You can disable ASR from the HP SIM console or through RBSU.

HP Systems Insight Manager

HP SIM is a web-based application that allows system administrators to accomplish normal administrative tasks from any remote location, using a web browser. HP SIM provides device management capabilities that consolidate and integrate management data from HP and third-party devices.



IMPORTANT: You must install and use HP SIM to benefit from the Pre-Failure Warranty for processors, SAS and SATA hard drives, and memory modules.

For additional information, refer to the Management CD in the HP ProLiant Essentials Foundation Pack or the HP SIM website (<http://www.hp.com/go/hpsim>).

HP Insight Diagnostics

HP Insight Diagnostics is a proactive server management tool, available in both offline and online versions, that provides diagnostics and troubleshooting capabilities to assist IT administrators who verify server installations, troubleshoot problems, and perform repair validation.

HP Insight Diagnostics Offline Edition performs various in-depth system and component testing while the OS is not running. To run this utility, launch the SmartStart CD.

HP Insight Diagnostics Online Edition is a web-based application that captures system configuration and other related data needed for effective server management. Available in Microsoft® Windows® and Linux versions, the utility helps to ensure proper system operation.

For more information or to download the utility, refer to the HP website (<http://www.hp.com/servers/diags>).

USB support

HP provides both standard USB 2.0 support and legacy USB 2.0 support. Standard support is provided by the OS through the appropriate USB device drivers. Before the OS loads, HP provides support for USB devices through legacy USB support, which is enabled by default in the system ROM.

Legacy USB support provides USB functionality in environments where USB support is not available normally. Specifically, HP provides legacy USB functionality for the following:

- POST
- RBSU
- Diagnostics
- DOS
- Operating environments which do not provide native USB support

Troubleshooting the system using port 85 codes

For example, if the port 85 code displays "31h," see "Processor-related port 85 codes (on page 64)" for more information.

Port 85 code	Description
3xh	Port 85 codes in this format indicate processor-related errors. See "Processor-related port 85 codes (on page 64)" for more information.
4xh	Port 85 codes in this format indicate memory-related errors. See "Memory-related port 85 codes (on page 64)" for more information.
6xh	Port 85 codes in this format indicate expansion board-related errors. See "Expansion board-related port 85 codes (on page 65)" for more information.
All other codes, including 00h, 01h, and 5xh	Port 85 codes in this range cover several areas. See the section "Miscellaneous port 85 codes (on page 66)" for more information.

Processor-related port 85 codes

Processor-related port 85 codes display in the format 3xh.



IMPORTANT: Reboot the server after completing each numbered step. If the error condition continues, proceed with the next step.

To troubleshoot processor-related error codes:

1. Bring the server to base configuration by removing all components that are not required by the server to complete POST. This process can include removing all:

- o Expansion boards (on page 47)
- o Processors (on page 34), except the processor installed in socket 1



IMPORTANT: Processor socket 1 and PPM slot 1 must be populated at all times or the server does not function properly.

- o PPMs ("PPM" on page 40), except the PPM installed in slot 1
 - o DIMMs (on page 41), except the first bank
 - o Hard drives ("SAS or SATA hard drives" on page 43)
 - o Peripheral devices
2. Reseat the processor in socket 1.
 3. Reseat the remaining processors, rebooting after each installation to identify any failed processors.



IMPORTANT: Populate the processors in the following order: 1, 2, 4, 3.



IMPORTANT: Always install a PPM when you install a processor. The system fails to boot if the PPM is missing.

4. Replace the processor in socket 1.
5. Replace the processor board, if applicable.
6. Replace the system board.



IMPORTANT: If replacing the system board or clearing NVRAM, you must re-enter the server serial number through RBSU ("Re-entering the server serial number and product ID" on page 57).

Memory-related port 85 codes

Memory-related port 85 codes display in the format 4xh.



IMPORTANT: Reboot the server after completing each numbered step. If the error condition continues, proceed with the next step.

To troubleshoot memory-related error codes:

1. Check the memory LEDs ("Systems Insight Display LEDs" on page 77) for any identified errors or failed DIMMs, and take corrective action.
2. Bring the server to base configuration by removing all components that are not required by the server to complete POST. This process can include removing all:

- Expansion boards (on page 47)
- Processors (on page 34), except the processor installed in socket 1



IMPORTANT: Processor socket 1 and PPM slot 1 must be populated at all times or the server does not function properly.

- PPMs ("PPM" on page 40), except the PPM installed in slot 1
 - DIMMs (on page 41), except the first bank
 - Hard drives ("SAS or SATA hard drives" on page 43)
 - Peripheral devices
3. Reseat the remaining memory boards, rebooting after each installation to isolate any failed memory boards, if applicable.
 4. Replace the DIMMs with a remaining bank of memory.
 5. Replace the memory board, if applicable.
 6. Replace the system board.



IMPORTANT: If replacing the system board or clearing NVRAM, you must re-enter the server serial number through RBSU ("Re-entering the server serial number and product ID" on page 57).

Expansion board-related port 85 codes

Expansion board-related port 85 codes display in the format 6xh.



IMPORTANT: Reboot the server after completing each numbered step. If the error condition continues, proceed with the next step.

To troubleshoot expansion board-related error codes:

1. Reseat all expansion boards.
2. Bring the server to base configuration by removing all components that are not required by the server to complete POST. This process can include removing all:
 - Expansion boards (on page 47)
 - Processors (on page 34), except the processor installed in socket 1



IMPORTANT: Processor socket 1 and PPM slot 1 must be populated at all times or the server does not function properly.

- PPMs ("PPM" on page 40), except the PPM installed in slot 1
 - DIMMs (on page 41), except the first bank
 - Hard drives ("SAS or SATA hard drives" on page 43)
 - Peripheral devices
3. Install the expansion boards one at a time, rebooting between each installation to isolate the failed expansion board.
 4. Replace the failed expansion board, if applicable.
 5. Replace the PCI riser board, if applicable.
 6. Replace the system board.



IMPORTANT: If replacing the system board or clearing NVRAM, you must re-enter the server serial number through RBSU ("Re-entering the server serial number and product ID" on page 57).

Miscellaneous port 85 codes

To troubleshoot all other port 85 codes:



IMPORTANT: Reboot the server after completing each numbered step. If the error condition continues, proceed with the next step.

1. Bring the server to base configuration by removing all components that are not required by the server to complete POST. This process can include removing all:
 - o Expansion boards (on page 47)
 - o Processors (on page 34), except the processor installed in socket 1



IMPORTANT: Processor socket 1 and PPM slot 1 must be populated at all times or the server does not function properly.

- o PPMs ("PPM" on page 40), except the PPM installed in slot 1
 - o DIMMs (on page 41), except the first bank
 - o Hard drives ("SAS or SATA hard drives" on page 43)
 - o Peripheral devices
2. Install each remaining system component, rebooting between each installation to isolate any failed components.
 3. Clear the system NVRAM ("System maintenance switch (SW3)" on page 75).
 4. Replace the system board.



IMPORTANT: If replacing the system board or clearing NVRAM, you must re-enter the server serial number through RBSU ("Re-entering the server serial number and product ID" on page 57).

Component identification

Front panel components

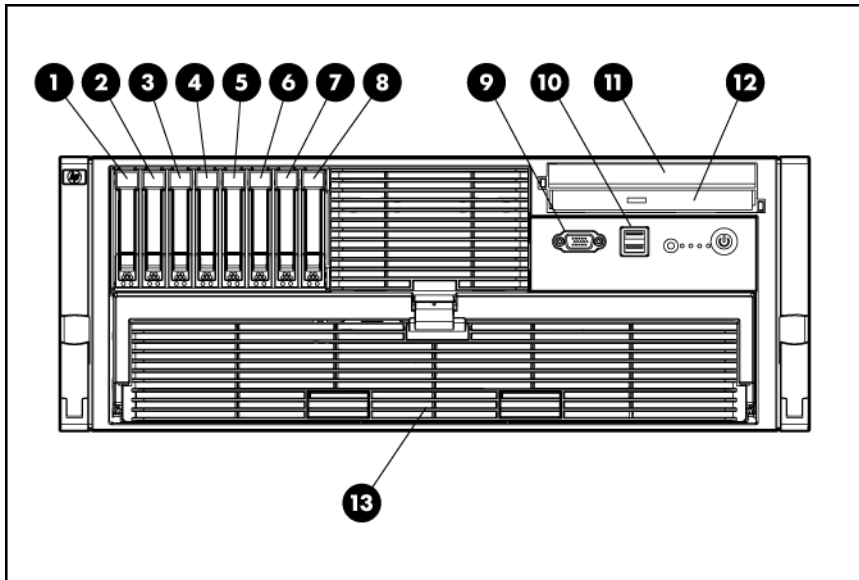

Item	Description
1	Hard drive bay 1
2	Hard drive bay 2
3	Hard drive bay 3
4	Hard drive bay 4
5	Hard drive bay 5
6	Hard drive bay 6
7	Hard drive bay 7
8	Hard drive bay 8
9	Video connector
10	USB connectors (two)
11	Media drive blank or optional media drive
12	DVD drive
13	Processor memory module

Front panel LEDs and buttons

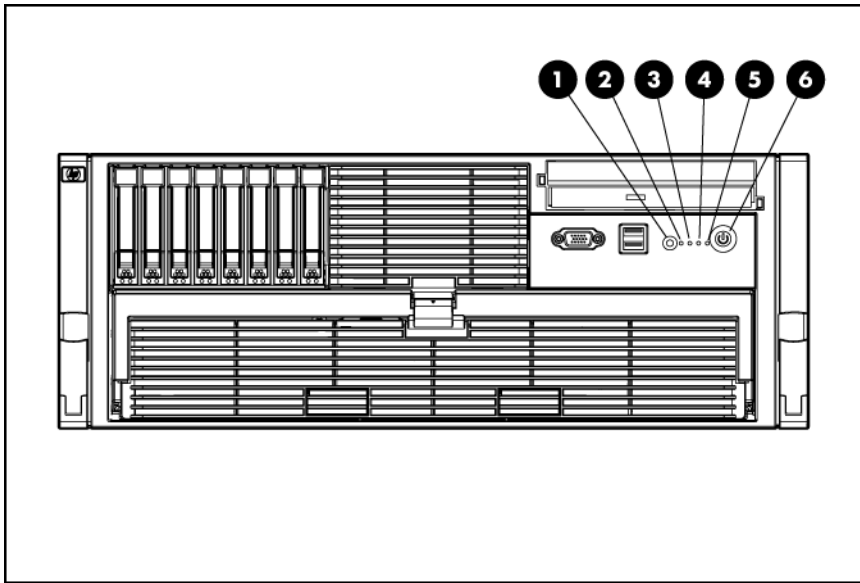

Item	Description	Status
1	UID switch and LED	Blue = Activated Flashing blue = Server managed remotely Off = Deactivated
2	Internal system health LED	Green = Normal (system on) Flashing amber = System health degraded Flashing red = System health critical Off = Normal (system off)
3	External system health LED	Green = Normal (system on) Flashing amber = System health degraded Flashing red = System health critical Off = Normal (system off)
4	NIC 1 link/activity LED	Green = Linked to network Flashing green = Linked with activity on the network Off = No network connection
5	NIC 2 link/activity LED	Green = Linked to network Flashing green = Linked with activity on the network Off = No network connection
6	Power on/Standby button and LED	Amber = System has AC power and is in standby mode Green = System has AC power and is turned on Off = System has no AC power

Processor memory module components

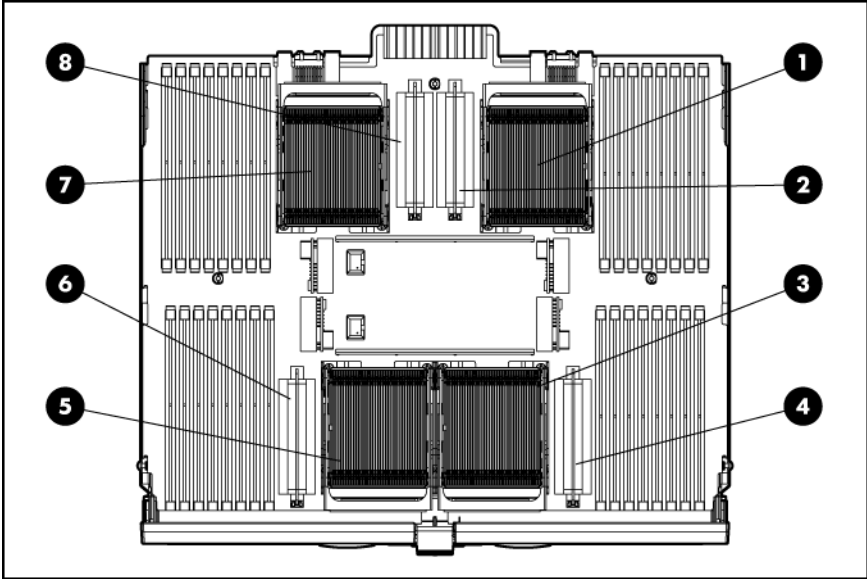

Item	Description
1	Processor socket 1 (boot processor)
2	PPM socket 1
3	Processor socket 3
4	PPM socket 3
5	Processor socket 4
6	PPM socket 4
7	Processor socket 2
8	PPM socket 2

See "Processor options" in the *HP ProLiant DL585 G6 Server User Guide* for population guidelines.

DIMM slot identification

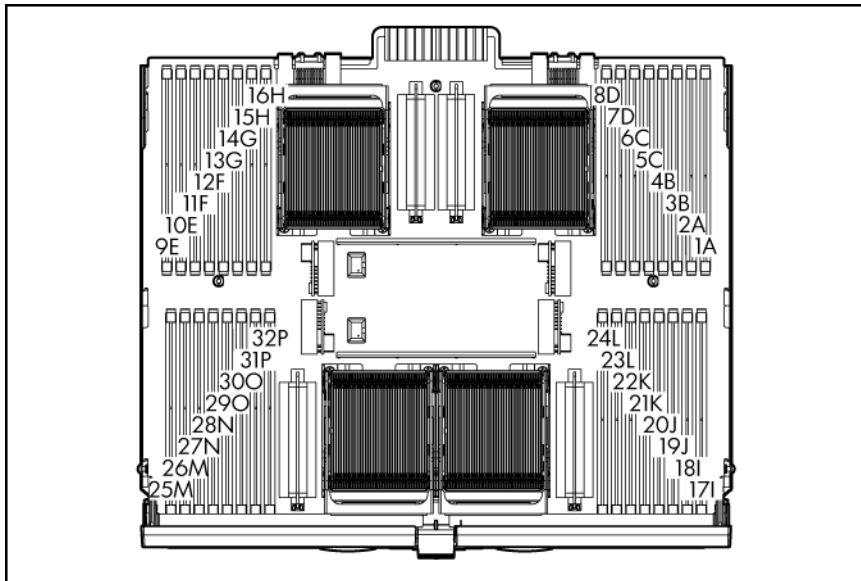

Each memory node consists of eight DIMM slots in four banks. See "Memory options" in the *HP ProLiant DL585 G6 Server User Guide* for DIMM population guidelines.

SAS and SATA hard drive LEDs

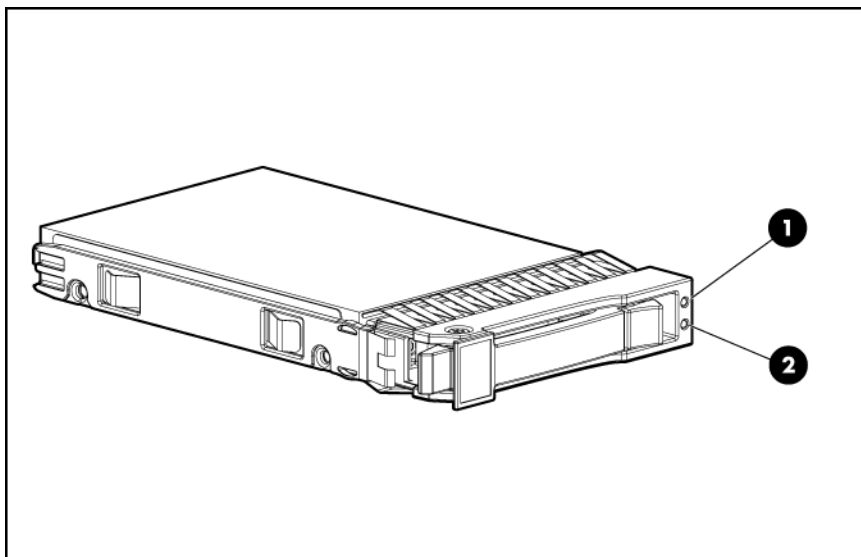

Item	Description	Status
1	Fault/UID LED	Amber = Drive failure Flashing amber = Fault-process activity Blue = Unit identification is active Off = No fault-process activity
2	Online/activity LED	Green = Drive activity Flashing green = High activity on the drive or drive is being configured as part

Item	Description	Status
		of an array Off = No drive activity

SAS and SATA hard drive LED combinations

Online/activity LED (green)	Fault/UID LED (amber/blue)	Interpretation
On, off, or flashing	Alternating amber and blue	The drive has failed, or a predictive failure alert has been received for this drive; it also has been selected by a management application.
On, off, or flashing	Steadily blue	The drive is operating normally, and it has been selected by a management application.
On	Amber, flashing regularly (1 Hz)	A predictive failure alert has been received for this drive. Replace the drive as soon as possible.
On	Off	The drive is online, but it is not active currently.
Flashing regularly (1 Hz)	Amber, flashing regularly (1 Hz)	Do not remove the drive. Removing a drive may terminate the current operation and cause data loss. The drive is part of an array that is undergoing capacity expansion or stripe migration, but a predictive failure alert has been received for this drive. To minimize the risk of data loss, do not replace the drive until the expansion or migration is complete.
Flashing regularly (1 Hz)	Off	Do not remove the drive. Removing a drive may terminate the current operation and cause data loss. The drive is rebuilding, or it is part of an array that is undergoing capacity expansion or stripe migration.
Flashing irregularly	Amber, flashing regularly (1 Hz)	The drive is active, but a predictive failure alert has been received for this drive. Replace the drive as soon as possible.
Flashing irregularly	Off	The drive is active, and it is operating normally.
Off	Steadily amber	A critical fault condition has been identified for this drive, and the controller has placed it offline. Replace the drive as soon as possible.
Off	Amber, flashing regularly (1 Hz)	A predictive failure alert has been received for this drive. Replace the drive as soon as possible.
Off	Off	The drive is offline, a spare, or not configured as part of an array.

Rear panel components

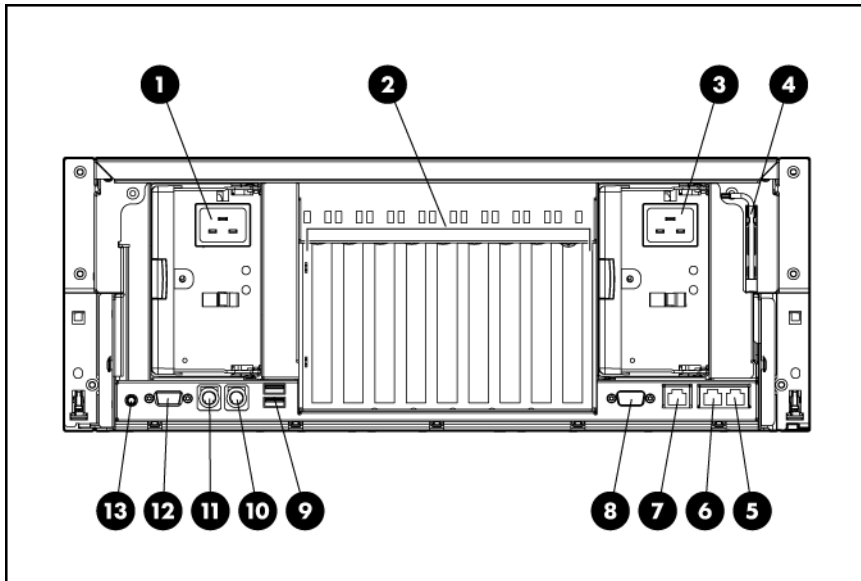

Item	Description
1	Redundant hot-plug power supply (optional)
2	PCI Express and PCI-X non-hot-plug expansion slots
3	Hot-plug power supply (primary)
4	T-15 Torx screwdriver
5	NIC connector 1
6	NIC connector 2
7	iLO 2 connector
8	Serial connector
9	USB connectors (two)
10	Keyboard connector
11	Mouse connector
12	Video connector
13	Rear UID button and LED

See "Expansion boards (on page 47)" for expansion slot definitions.

Rear panel LEDs and buttons

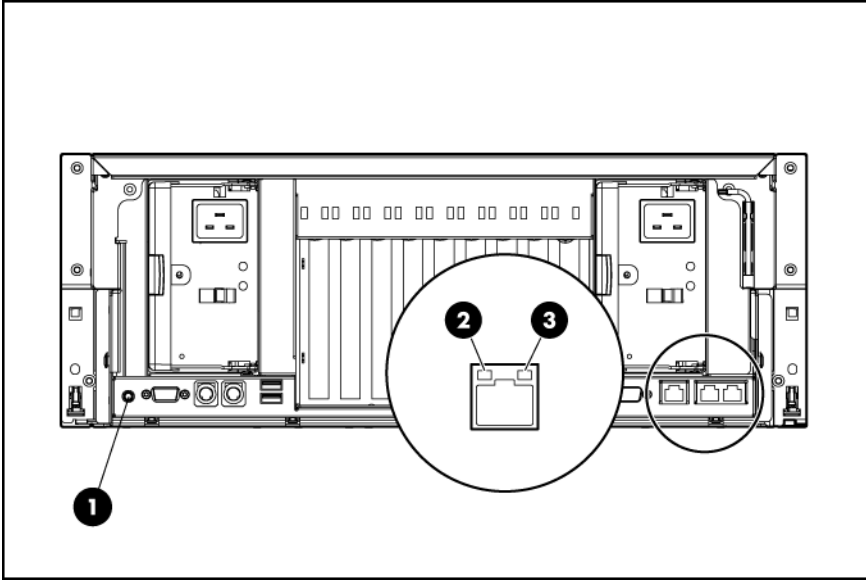

Item	Description	LED color	Status
1	UID LED	Blue	On = Activated Flashing = Server remotely managed Off = Deactivated
2	Activity LED	Green	On or flashing = Network activity Off = No network activity
3	Link LED	Green	On = Linked to network Off = Not linked to network

Hot-plug power supply LEDs

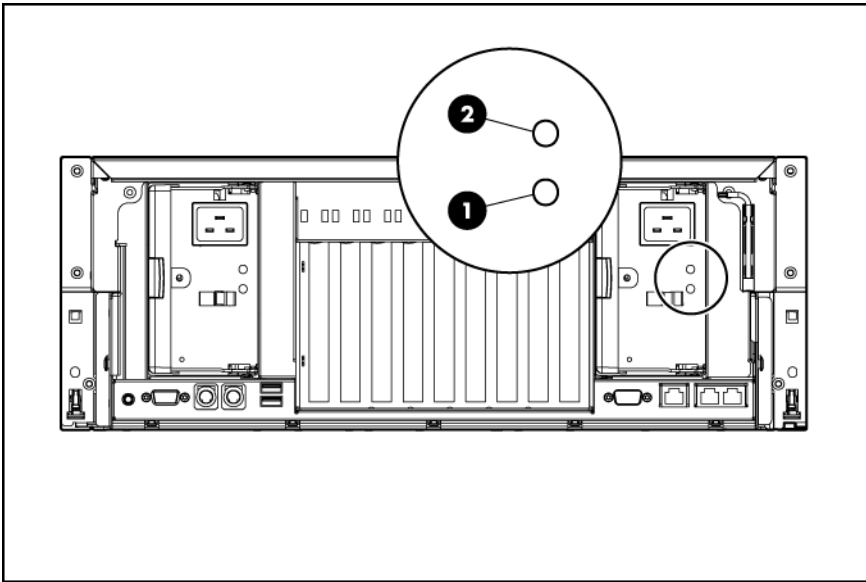

Fail LED 1 (amber)	Power LED 2 (green)	Description
Off	Off	No AC power to any power supply
Flashing	Off	Power supply failure (over current)
On	Off	No AC power to this power supply
Off	Flashing	<ul style="list-style-type: none"> • AC power present • Standby mode
Off	On	Normal

Internal components

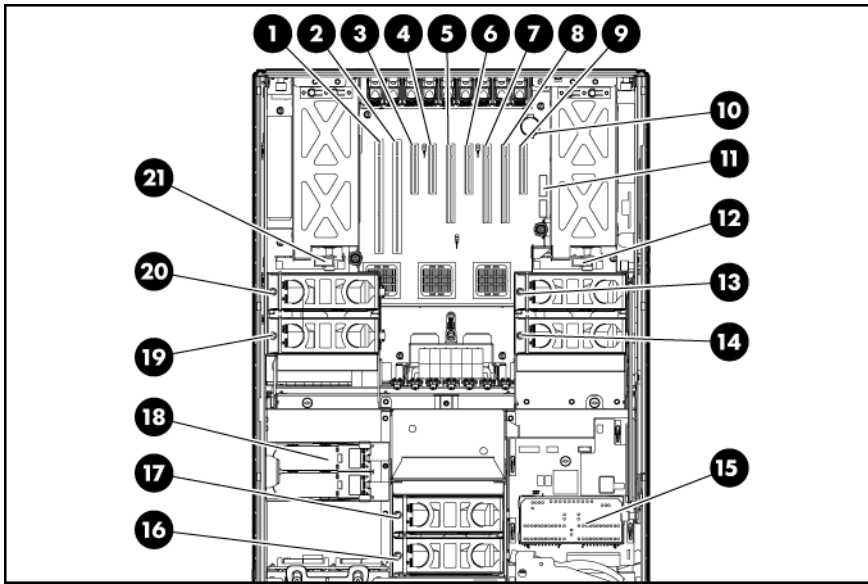

Item	Description
1	PCI-X non-hot-plug expansion slot 1, 64-bit/100-MHz (half-length)
2	PCI-X non-hot-plug expansion slot 2, 64-bit/100-MHz (full-length)
3	PCI Express x4 non-hot-plug expansion slot 3 (full-length)
4	PCI Express x4 non-hot-plug expansion slot 4 (full-length)
5	PCI Express x8 non-hot-plug expansion slot 5 (full-length)
6	PCI Express x4 non-hot-plug expansion slot 6 (full-length)
7	PCI Express x8 non-hot-plug expansion slot 7 (full-length)
8	PCI Express x8 non-hot-plug expansion slot 8 (full-length)
9	PCI Express x4 non-hot-plug expansion slot 9 (half-

Item	Description
	length)
10	System battery
11	System maintenance switch (SW3)
12	Power supply backplane
13	Fan 6 connector
14	Fan 5 connector
15	Media board
16	Fan 1 connector
17	Fan 2 connector
18	BBWC battery pack
19	Fan 3 connector
20	Fan 4 connector
21	Power supply backplane

System maintenance switch (SW3)

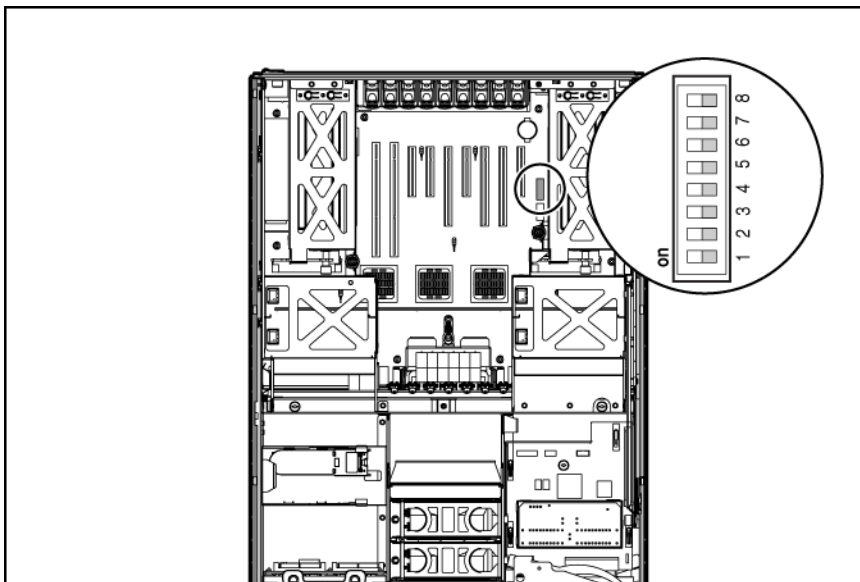

The system maintenance switch (SW3) is an eight-position switch that is used for system configuration. The default position for all eight positions is Off (closed).

Position	Description	Function
1	iLO 2 security	Off = iLO 2 security is enabled. On = iLO 2 security is disabled.
2	Configuration lock	Off = System configuration can be changed. On = System configuration is locked.

Position	Description	Function
3	Reserved	Reserved
4	Reserved	Reserved
5	Password protection override	Off = Password is enabled. On = Password is disabled.
6	Configuration validation	Off = Switch has no function. On = Setting clears CMOS and NVRAM.
7	Reserved	Reserved
8	Reserved	Reserved

When the system maintenance switch position 6 is set to the On position, the system is prepared to erase all system configuration settings from both CMOS and NVRAM.

⚠ CAUTION: Clearing CMOS and/or NVRAM deletes configuration information. Be sure to properly configure the server or data loss could occur.

Media board components

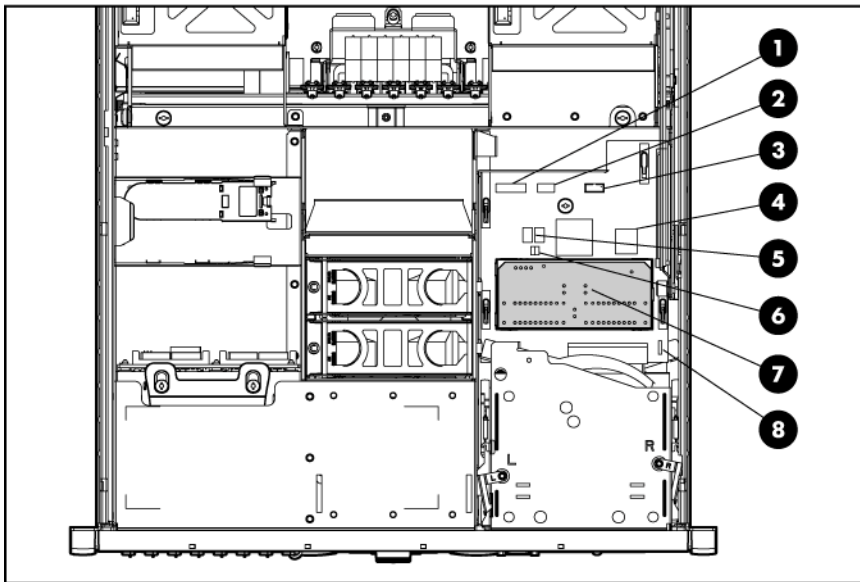

Item	Description
1	Power button cable connector
2	USB cable connector
3	Video cable connector
4	Internal USB connector
5	Port 84/85 code display
6	Port 84/85 code display switch
7	System Insight Display
8	Boot device selector switch (SW1)

Boot device selector switch (SW1)

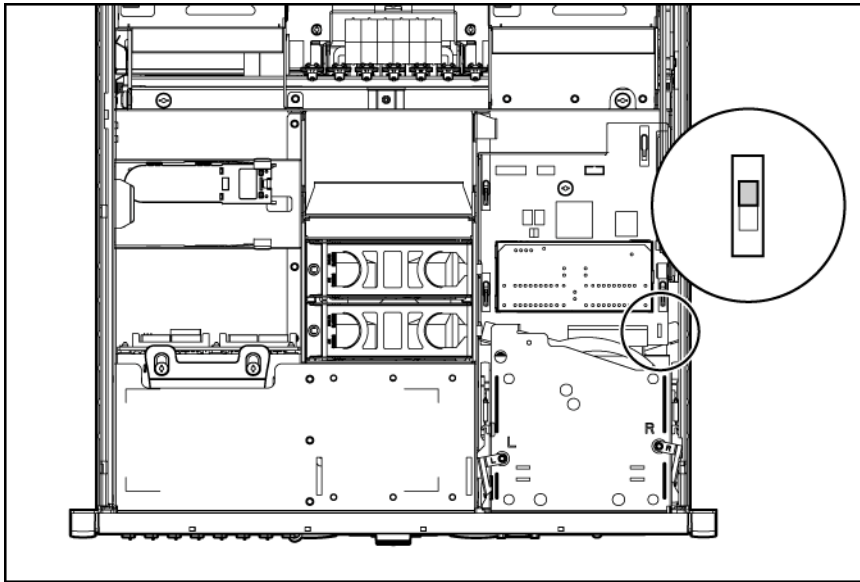

The boot device selector switch setting determines the device access order of the media drives in the server. The default setting for the boot device selector switch is FLP TOP.

When the boot device selector switch is set to FLP TOP, the optical drive in the bottom bay is designated as the primary optical drive. The diskette drive in the top bay is bootable. The server cannot boot from a diskette drive in the bottom bay when the boot device selector switch is set to FLP TOP.

When the boot device selector switch is set to FLP BOT, the optical drive in the top bay is designated as the primary optical drive. The diskette drive in the bottom bay is bootable. The server cannot boot from a diskette drive in the top bay when the boot device selector switch is set to FLP BOT.

Switch setting	Description
FLP TOP (default)	The diskette drive in top bay is bootable. The primary optical drive in bottom bay is bootable.
FLP BOT	The primary optical drive in top bay is bootable. The diskette drive in bottom bay is bootable.

Systems Insight Display LEDs

The front panel health LEDs indicate only the current hardware status. In some situations, HP SIM might report server status differently than the health LEDs because the software tracks more system attributes. The System Insight Display LEDs identify components experiencing an error, event, or failure.

The Systems Insight Display LEDs are located on the media board. In normal operations, all of the LEDs are off unless one of the components fails.



IMPORTANT: When removing the access panel to view the Systems Insight Display LEDs (on page 77), leave the server powered on. The Systems Insight Display LEDs are cleared when the server is powered off.

NOTE: The system management driver must be installed for the internal system health LED to provide pre-failure and warranty conditions.

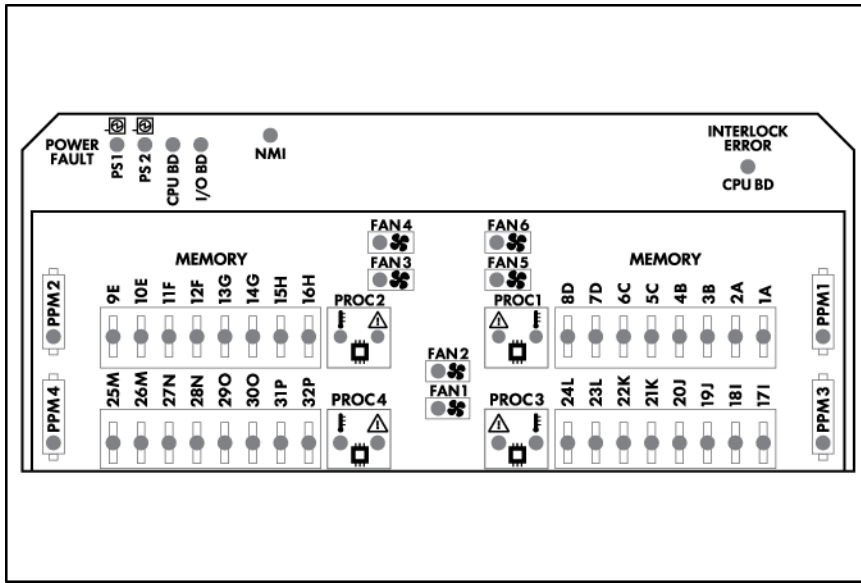

LED	Component
PS1	Power supply (primary)
PS2	Power supply (optional)
CPU BD (Power Fault)	Processor memory module board
I/O BD	System board
NMI	System NMI switch
CPU BD (Interlock Error)	System board
PPM X	Processor power module
1A–32P	DIMM slot
PROC X	Processor
FAN X	Fan

Battery pack LEDs

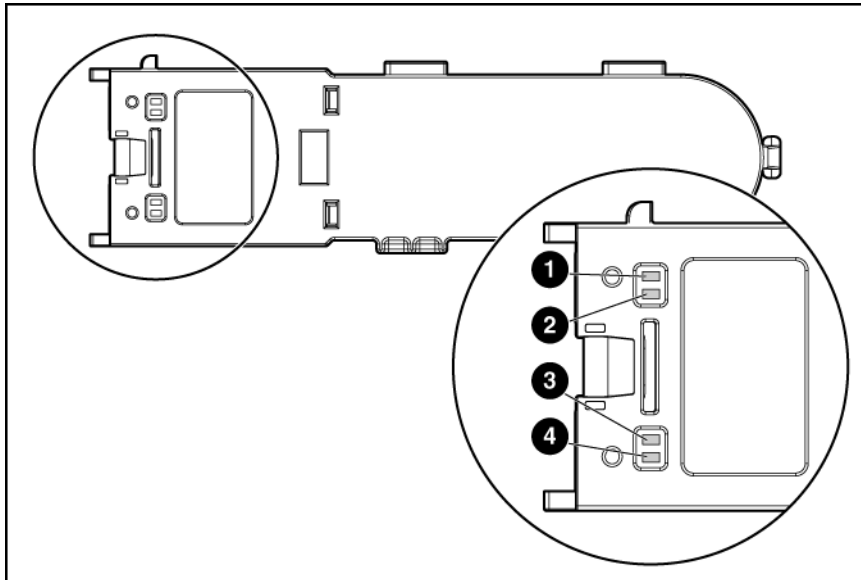

Item ID	Color	Description
1	Green	System Power LED. This LED glows steadily when the system is powered up and 12 V system power is available. This power supply is used to maintain the battery charge and provide supplementary power to the cache microcontroller.
2	Green	Auxiliary Power LED. This LED glows steadily when 3.3V auxiliary voltage is detected. The auxiliary voltage is used to preserve BBWC data and is available any time that the system power cords are connected to a power supply.
3	Amber	Battery Health LED. To interpret the illumination patterns of this LED, see the following table.
4	Green	BBWC Status LED. To interpret the illumination patterns of this LED, see the following table.

LED3 pattern	LED4 pattern	Interpretation
—	One blink every two seconds	The system is powered down, and the cache contains data that has not yet been written to the drives. Restore system power as soon as possible to prevent data loss. Data preservation time is extended any time that 3.3 V auxiliary power is available, as indicated by LED 2. In the absence of auxiliary power, battery power alone preserves the data. A fully-charged battery can normally preserve data for at least two days. The battery lifetime also depends on the cache module size. For further information, refer to the controller QuickSpecs on the HP website (http://www.hp.com).
—	Double blink, then pause	The cache microcontroller is waiting for the host controller to communicate.
—	One blink per second	The battery pack is below the minimum charge level and is being charged. Features that require a battery (such as write cache,

LED3 pattern	LED4 pattern	Interpretation
		capacity expansion, stripe size migration, and RAID migration) are temporarily unavailable until charging is complete. The recharge process takes between 15 minutes and two hours, depending on the initial capacity of the battery.
—	Steady glow	The battery pack is fully charged, and posted write data is stored in the cache.
—	Off	The battery pack is fully charged, and there is no posted write data in the cache.
One blink per second	One blink per second	An alternating green and amber blink pattern indicates that the cache microcontroller is executing from within its boot loader and receiving new flash code from the host controller.
Steady glow	—	There is a short circuit across the battery terminals or within the battery pack. BBWC features are disabled until the battery pack is replaced. The life expectancy of a battery pack is typically more than three years.
One blink per second	—	There is an open circuit across the battery terminals or within the battery pack. BBWC features are disabled until the battery pack is replaced. The life expectancy of a battery pack is typically more than three years.

Fan locations

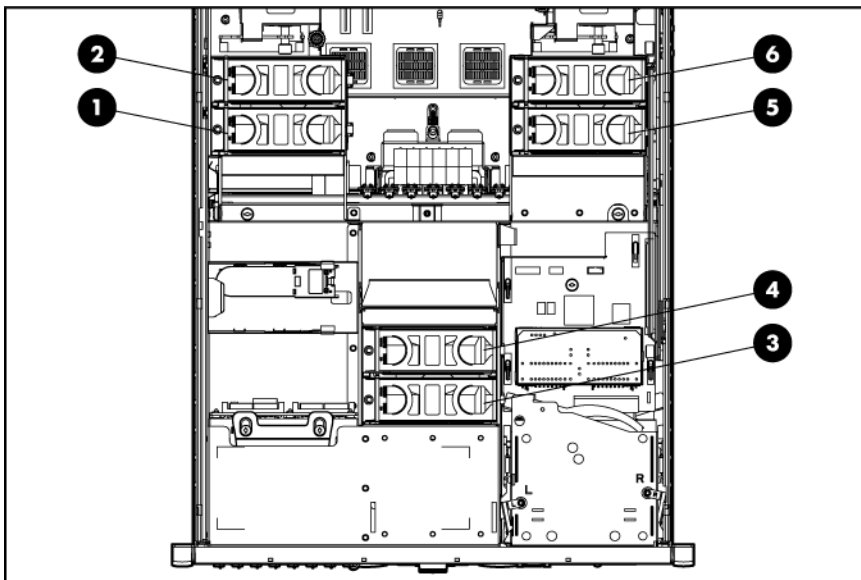

Item	Description
1	Fan 3
2	Fan 4
3	Fan 1
4	Fan 2
5	Fan 5
6	Fan 6

See "Hot-plug fans (on page 45)" for replacement procedures and operation guidelines.

Hot-plug fan LEDs

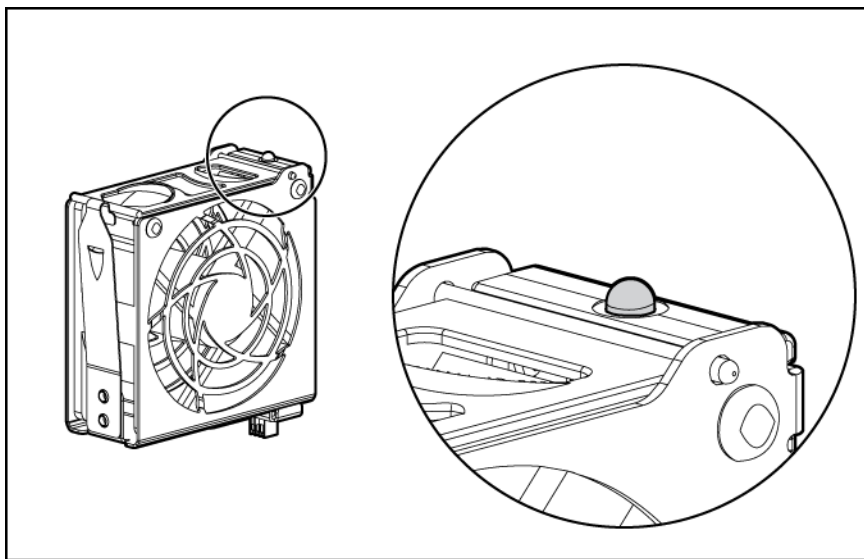

Status
Green = Operating normally
Amber = Failed
Off = No power

Cabling

BBWC cabling

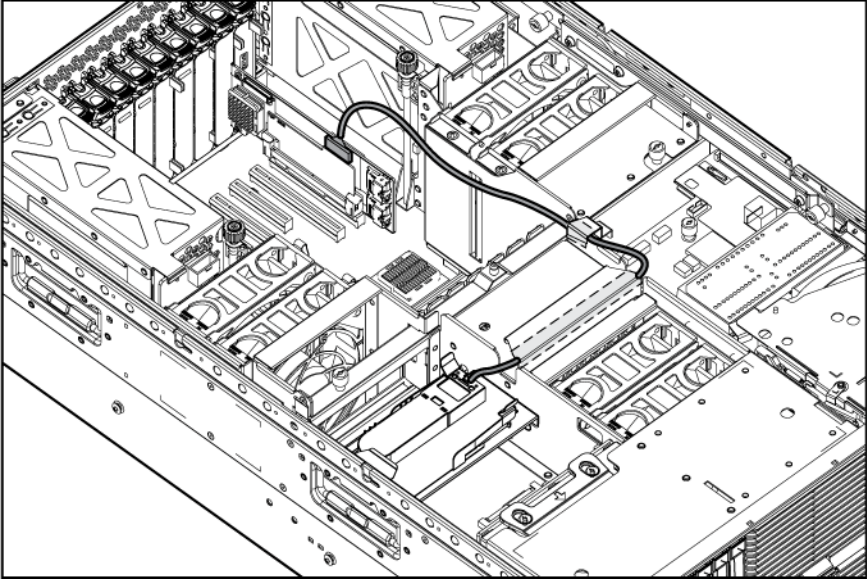

Front panel cable components

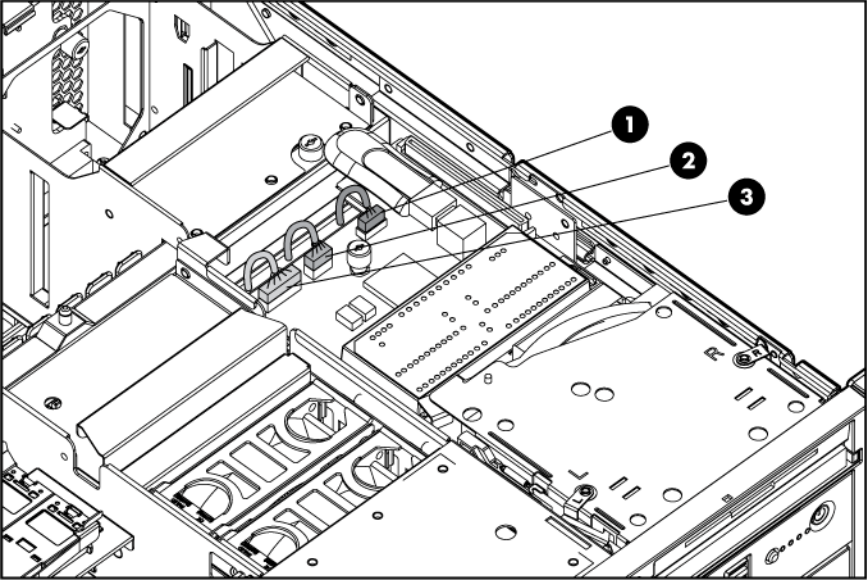

Item	Description
1	Video connector cable assembly
2	USB connector cable assembly

Item	Description
3	Power button cable assembly

SAS and SATA hard drive data cable routing

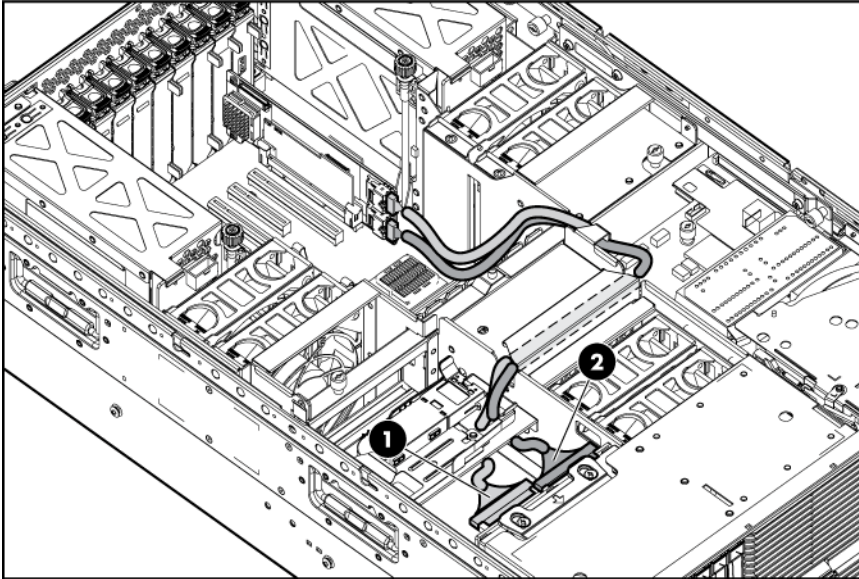

CAUTION: When routing cables, always be sure that the cables are not in a position where they can be pinched or crimped.

NOTE: The SAS power cable is not shown.

SAS and SATA power cable routing

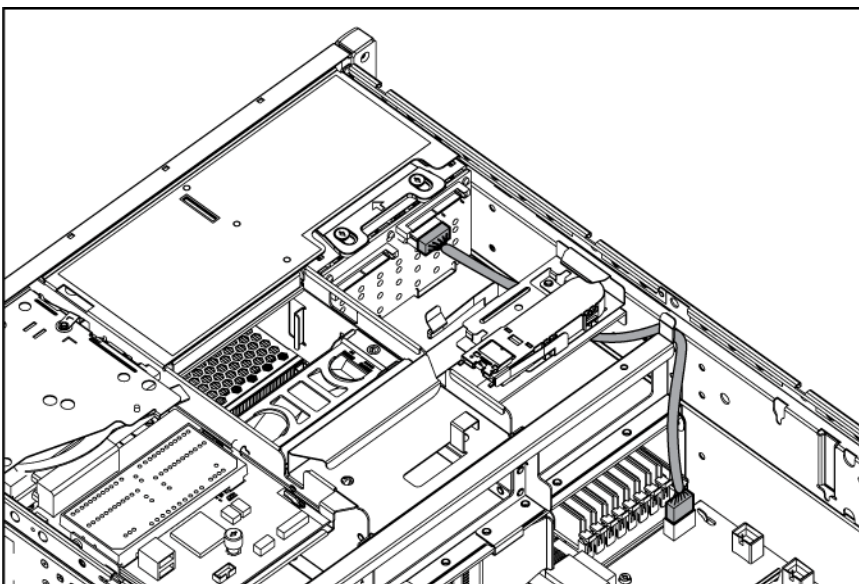

△ **CAUTION:** When routing cables, always be sure that the cables are not in a position where they can be pinched or crimped.

NOTE: The SAS data cables are not shown.

Graphics card power cabling

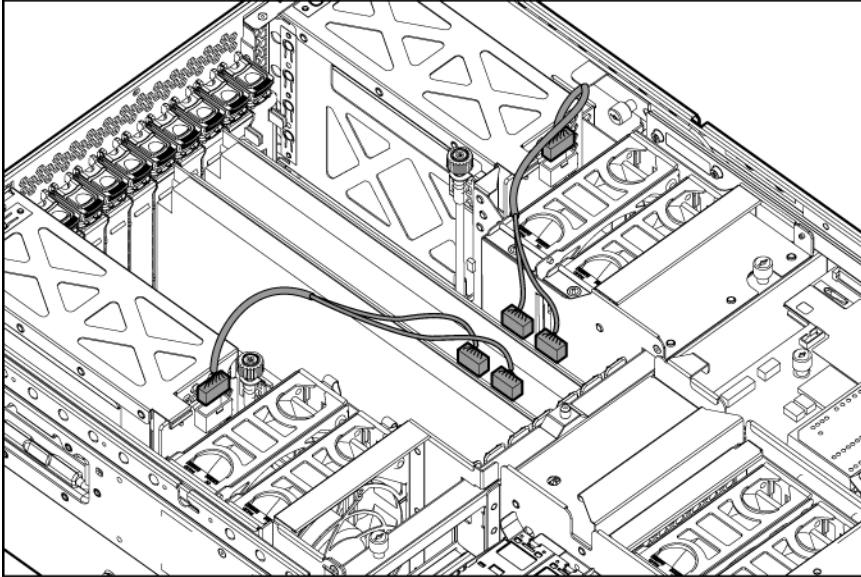

Specifications

Environmental specifications

Specification	Value
Temperature range*	
Operating	10°C to 35°C (50°F to 95°F)
Shipping	-40°C to 70°C (-40°F to 158°F)
Maximum wet bulb temperature	28°C (82.4°F)
Relative humidity (noncondensing)**	
Operating	10% to 90%
Non-operating	5% to 95%

* All temperature ratings shown are for sea level. An altitude derating of 1°C per 300 m (1.8°F per 1,000 ft) to 3048 m (10,000 ft) is applicable. No direct sunlight allowed.

** Storage maximum humidity of 95% is based on a maximum temperature of 45°C (113°F). Altitude maximum for storage corresponds to a pressure minimum of 70 kPa.

Server specifications

Specification	Value
Dimension	
Height	17.6 cm (6.94 in)
Depth	67.3 cm (26.5 in)
Width	48.3 cm (19.0 in)
Maximum weight (all hard drives, power supplies, and processors installed)	43 kg (95 lb)
Minimum weight (one hard drive, one power supply, and one processor installed)	36 kg (79 lb)
Input requirement	
Rated input voltage	100-127 VAC 200-240 VAC
Rated input frequency	50-60 Hz
Rated input current	@ 100 VAC-12A @ 200 VAC-8A
Rated input power	@100 VAC-1161 W @200 VAC-1598 W

Specification	Value
BTUs per hour	@100 VAC–3960 BTU @200 VAC–5450 BTU
Power supply output	
Power supply output	910 W (low line) 1300 W (high line)

Technical support

Before you contact HP

Be sure to have the following information available before you call HP:

- Technical support registration number (if applicable)
- Product serial number
- Product model name and number
- Product identification number
- Applicable error messages
- Add-on boards or hardware
- Third-party hardware or software
- Operating system type and revision level

HP contact information

For the name of the nearest HP authorized reseller:

- See the Contact HP worldwide (in English) webpage (<http://welcome.hp.com/country/us/en/wwcontact.html>).

For HP technical support:

- In the United States, for contact options see the Contact HP United States webpage (http://welcome.hp.com/country/us/en/contact_us.html). To contact HP by phone:
 - Call 1-800-HP-INVENT (1-800-474-6836). This service is available 24 hours a day, 7 days a week. For continuous quality improvement, calls may be recorded or monitored.
 - If you have purchased a Care Pack (service upgrade), call 1-800-633-3600. For more information about Care Packs, refer to the HP website (<http://www.hp.com/hps>).
- In other locations, see the Contact HP worldwide (in English) webpage (<http://welcome.hp.com/country/us/en/wwcontact.html>).

Acronyms and abbreviations

ABEND

abnormal end

AMD

Advanced Micro Devices

ASR

Automatic Server Recovery

BBWC

battery-backed write cache

BIOS

Basic Input/Output System

CSR

Customer Self Repair

DIMM

dual inline memory module

DOS

disk operating system

iLO 2

Integrated Lights-Out 2

IML

Integrated Management Log

ISEE

Instant Support Enterprise Edition

NIC

network interface controller

NiMH

nickel metal hydride

NVRAM

non-volatile memory

ORCA

Option ROM Configuration for Arrays

OS

operating system

PCI-X

peripheral component interconnect extended

POST

Power-On Self Test

PPM

processor power module

RAID

redundant array of inexpensive (or independent) disks

RBSU

ROM-Based Setup Utility

RILOE II

Remote Insight Lights-Out Edition II

ROM

read-only memory

SAS

serial attached SCSI

SATA

serial ATA

SCSI

small computer system interface

SIM

Systems Insight Manager

SNMP

Simple Network Management Protocol

TDP

Thermal Design Power

UID

unit identification

UPS

uninterruptible power system

USB

universal serial bus

Index

A

access panel 27
adapter LEDs 68, 73
ASR (Automatic Server Recovery) 62
authorized reseller 87
Automatic Server Recovery (ASR) 62
Autorun menu 59

B

backplane, power supply 55
backplane, SAS 48
Basic Input/Output System (BIOS) 61
battery 57, 74
battery pack LEDs 79
battery-backed write cache (BBWC) 50, 52, 53,
74, 79, 82
battery-backed write cache battery pack 50, 52, 74
battery-backed write cache cabling 82
BBWC (battery-backed write cache) 50, 52, 53,
74, 79, 82
bezel, fan 33
bezel, power button assembly 30
bezel, processor memory module 34
BIOS (Basic Input/Output System) 61
BIOS upgrade 61
blanks 43, 44
boot device selector switch 77
buttons, front panel 68
buttons, rear panel 73

C

cabling 82
cabling, BBWC 82
cabling, graphics card 84
cabling, hard drive backplane 83
cabling, power button 76, 82
cabling, USB 82
cabling, video 82
cache module 50, 53
clearing NVRAM 75
CMOS (complementary metal-oxide
semiconductor) 75

complementary metal-oxide semiconductor
(CMOS) 75
components, front panel 67, 68
components, identification 67
components, internal 74
components, media board 76, 77
components, rear 72, 73
components, system board 74, 75
connector, external power 72
connector, fan 74
connector, iLO 2 72
connector, internal USB 76
connector, keyboard 72
connector, mouse 72
connector, NIC 72
connector, power button cable 32, 76
connector, serial 72
connector, USB 67, 72, 76, 82
connector, video 67, 72, 76, 82
contacting HP 87
CSR (customer self repair) 6
customer self repair (CSR) 6, 87

D

diagnostic tools 59, 61, 62, 63
diagnostics utility 63
DIMM slot locations 41, 70
DIMMs 41
diskette boot 77
diskette drive 43
dual in-line memory module (DIMM) 41
DVD-ROM drive 43

E

electrostatic discharge 24
environmental requirements 85
environmental specifications 85
expansion board 47
expansion board-related port 85 codes 65
expansion slot covers 46
expansion slots 72, 74
extending server from rack 26
external health LED 68

external power connector 72

F

fan bezel 33
fan connectors 74
fan LED 77, 81
fans 45, 80, 81
features 67
front panel buttons 68
front panel components 67, 68
front panel LEDs 68, 77

G

graphics card cabling 84

H

hard drive bays 67
hard drive LEDs 70, 71
hard drives 43, 67, 71
hard drives, determining status of 70, 71
health driver 62
HP Insight Diagnostics 63
HP Insight Remote Support software 59
HP ProLiant Essentials Foundation Pack 62
HP Systems Insight Manager, overview 62
HP technical support 87
HP, contacting 87

I

illustrated parts catalog 17
iLO 2 (Integrated Lights-Out 2) 62, 73
iLO 2 connector 72
iLO NIC LED 73
IML (Integrated Management Log) 61
Insight Diagnostics 63
Insight Remote Support Software 59
Integrated Lights-Out 2 (iLO 2) 62, 73
Integrated Management Log (IML) 61
internal components 74
internal health LED 68, 77
internal USB connector 76

K

keyboard connector 72

L

LED, external health 68

LED, fan 77, 81
LED, iLO NIC 73
LED, internal health 68, 77
LED, power button 68
LEDs, battery pack 79
LEDs, front panel 68
LEDs, hard drive 70, 71
LEDs, NIC 68, 73
LEDs, power supply 73
LEDs, rear panel 73
LEDs, SAS hard drive 70, 71
LEDs, SATA hard drive 70, 71
LEDs, Systems Insight Display 27, 77
LEDs, unit identification (UID) 68, 72, 73

M

management tools 59
mechanical components 17
media board 49, 74, 76, 77
media drive 43, 67
media drive bay 67
media drive blank 43, 67
memory 41, 70
memory-related port 85 codes 64
miscellaneous port 85 codes 66
mouse connector 72

N

NIC connectors 72
NVRAM, clearing 75

O

Online ROM Flash Component Utility 61
Option ROM Configuration for Arrays (ORCA) 60
ORCA (Option ROM Configuration for Arrays) 60

P

part numbers 17
pass-through board 49
PCI expansion slot definitions 74
PCI Express 72, 74
phone numbers 87
port 84/85 display switch 76
port 85 code, expansion board-related 65
port 85 code, memory-related 64
port 85 code, miscellaneous 66
port 85 code, processor-related 64
port 85 code, troubleshooting 63

- port 85 code, viewing 77
- power button assembly bezel 30
- power button cable assembly 32
- power button cable connector 32, 76
- power button cabling 76, 82
- power button LED 68
- power connectors, external 72
- power connectors, internal 74
- Power On/Standby button 25, 68
- power supply 44, 72, 73
- power supply backplane 55
- power supply blank 44
- power supply LEDs 73
- powering down 25
- PPM (processor power module) 40, 69
- preparation procedures 25
- processor memory module 28, 42, 67, 69
- processor memory module bezel 34
- Processor Power Module (PPM) 40, 69
- processor socket 34, 69
- processor-related port 85 codes 64
- processors 34, 69

R

- rack, extending server from 26
- rack, removing server from 27
- RBSU (ROM-Based Setup Utility) 60
- rear panel buttons 73
- rear panel components 72
- rear panel LEDs 73
- recovering BBWC data 53
- redundant fan 45, 80, 81
- redundant system fan 45, 80, 81
- removal and replacement procedures 24
- removing server from rack 27
- required information 87
- required tools 24
- requirements, environmental 85
- ROM, updating 61
- ROM-Based Setup Utility (RBSU) 60
- ROMPaq utility 61

S

- safety considerations 24
- safety information 24
- SAS backplane 48
- SAS cabling 83
- SAS hard drive 43, 71
- SAS hard drive LEDs 70, 71

- SATA cabling 82, 83
- SATA hard drive 43, 71
- SATA hard drive LEDs 70, 71
- scripted installation 59
- serial connector 72
- serial number 57
- server asset text 57
- server specifications 85
- SmartStart autorun menu 59
- SmartStart Scripting Toolkit 59
- SmartStart, overview 59
- spare part numbers 17
- specifications 85
- specifications, environmental 85
- specifications, server 85
- static electricity 24
- status lights, battery pack 79
- support 87
- support packs 59
- switch, boot device selector 77
- switch, port 84/85 display 76
- switch, system maintenance 74, 75
- system board 56, 57, 74
- system board battery 57, 74
- system board components 74, 75
- system board switches 75
- system cage 54
- system components 67
- system maintenance switch 74, 75
- system power LED 25, 79
- Systems Insight Display 74, 77
- Systems Insight Display LEDs 77

T

- technical support 87
- telephone numbers 87
- Torx screwdriver 72

U

- UID (unit identification) 68, 72, 73
- UID LED 68, 72, 73
- unit identification (UID) 68, 72, 73
- USB cable assembly 31
- USB connector cabling 31, 76
- USB connectors 67, 72, 76, 82
- USB support 63
- utilities 59
- utilities, deployment 59, 60

V

video cable assembly 31

video connector 67, 72, 76, 82

video connector cabling 31, 82