

HP ProLiant ML310 Generation 2 Server Maintenance and Service Guide



August 2005 (Third Edition)
Part Number 378290-003

© Copyright 2005 Hewlett-Packard Development Company, L.P.

The information contained herein is subject to change without notice. The only warranties for HP products and services are set forth in the express warranty statements accompanying such products and services. Nothing herein should be construed as constituting an additional warranty. HP shall not be liable for technical or editorial errors or omissions contained herein.

Microsoft, Windows, and Windows NT are U.S. registered trademarks of Microsoft Corporation.

Linux is a U.S. registered trademark of Linus Torvalds.

August 2005 (Third Edition)

Part Number 378290-003

Audience assumptions

This document is for the person who installs, administers, and troubleshoots servers and storage systems. HP assumes you are qualified in the servicing of computer equipment and trained in recognizing hazards in products with hazardous energy levels.

Contents

Illustrated parts catalog	5
Customer self repair	5
Mechanical components	6
System components	7
Removal and replacement procedures	11
Required tools	11
Safety considerations	12
Preventing electrostatic discharge	12
Server warnings and cautions	12
Warnings and cautions	13
Preparation procedures	15
Powering down the server	15
Removing the server from the rack	15
Unlocking the bezel	16
Bezel	17
Hot-plug SCSI hard drive	17
Hot-plug SATA/SAS hard drive	18
Access panel	20
PCI expansion board	21
Battery	21
DIMM	23
DIMM installation guidelines	24
Air baffle	25
Fan	25
Power supply	27
Processor assembly	27
Diskette drive	30
CD-ROM/DVD-ROM drive	31
Installing a full-height tape drive option	32
Full-height tape drive	34
Power button/LED board	35
Hard drive (non-hot-plug)	37
Hot-plug SCSI backplane	38
Hot-plug SATA or SAS backplane	40
System board	42

Server cabling	45
Hot-plug SCSI cabling	45
Hot-plug SATA cabling	46
Non-hot-plug SCSI cabling.....	46
Non-hot-plug SATA cabling.....	47
SAS cabling	48
Diagnostic tools	49
Survey Utility	49
Array Diagnostic Utility.....	49
HP Insight Diagnostics.....	50
Integrated Management Log	50
Server component identification	53
Front panel components	53
Front panel LEDs and buttons.....	54
Rear panel components	55
Rear panel LEDs and buttons.....	56
System board components	57
System maintenance switch	57
System board LEDs	59
System LEDs and internal health LED combinations	60
SCSI IDs	62
Hot-plug SCSI hard drive LEDs	62
Hot-plug SCSI hard drive LED combinations	63
Hot-plug SATA or SAS IDs	64
SATA or SAS hard drive LEDs.....	65
Fan locations	66
Specifications	67
Server specifications	67
Environmental specifications	68
Hot-plug power supply calculations.....	68
1.44-MB diskette drive specifications.....	68
CD-ROM drive specifications.....	69
Acronyms and abbreviations	73
Index	77

Illustrated parts catalog

In this section

Customer self repair.....	5
Mechanical components	6
System components	7

Customer self repair

What is customer self repair?

HP's customer self-repair program offers you the fastest service under either warranty or contract. It enables HP to ship replacement parts directly to you so that you can replace them. Using this program, you can replace parts at your own convenience.

A convenient, easy-to-use program:

- An HP support specialist will diagnose and assess whether a replacement part is required to address a system problem. The specialist will also determine whether you can replace the part.
- Replacement parts are express-shipped. Most in-stock parts are shipped the very same day you contact HP. You may be required to send the defective part back to HP, unless otherwise instructed.
- Available for most HP products currently under warranty or contract. For information on the warranty service, refer to the HP website (<http://h18004.www1.hp.com/products/servers/platforms/warranty/index.html>).

For more information about HP's customer self-repair program, contact your local service provider. For the North American program, refer to the HP website (<http://www.hp.com/go/selfrepair>).

Customer replaceable parts are identified in the following tables.

Mechanical components

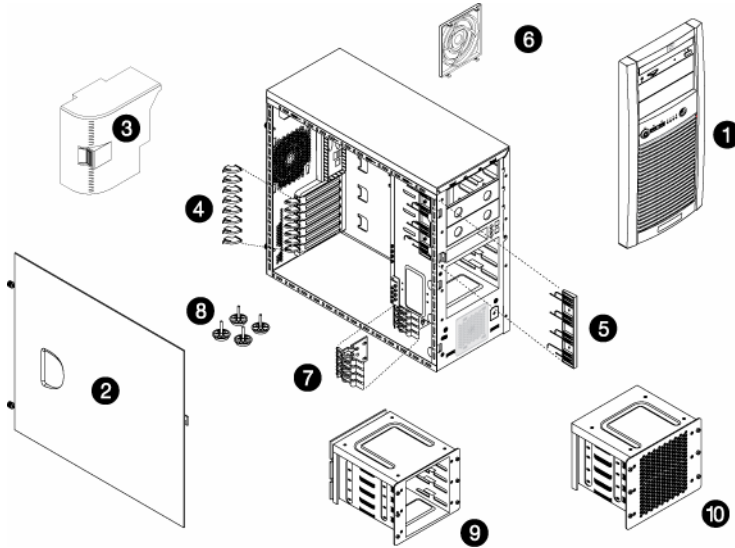

Item	Description	Assembly part number	Spare part number	Customer self repair
1	Bezel (w/o bezel key)	383678-001	382979-001	Yes
2	Access panel	—	—	—
3	Air baffle	385712-001	385758-001	Yes
	Plastics kit	—	382978-001	Yes
4	PCI retainer clips	—	—	Yes
5	Release lever, full height drive bay	—	—	Yes
6	Fan holder	—	—	Yes
7	PCI expansion board guide	—	—	Yes
8	Feet (4)	—	—	Yes
9	Hot-plug SATA hard drive cage	346078-001	345640-001	Yes
10	Non-hot-plug SATA/SCSI hard drive cage	346079-001	382992-001	Yes
11	Hot-plug SCSI hard drive cage*	384522-001	384756-001	Yes
12	Bezel key*	—	399394-001	Yes

* not shown

System components

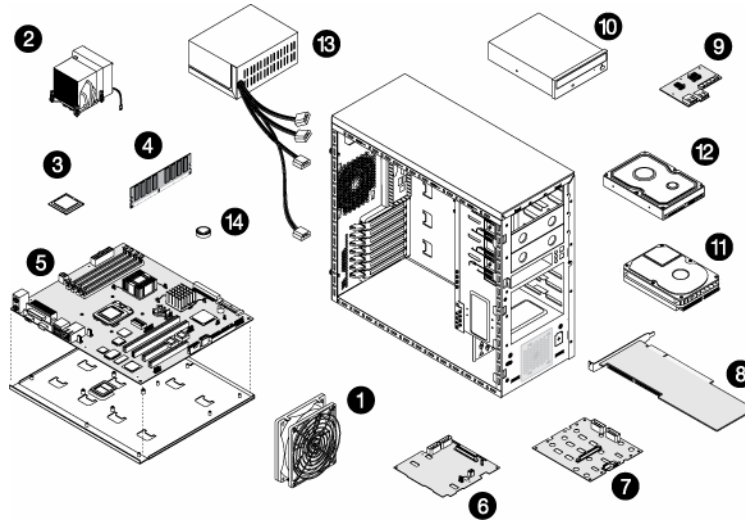

Item	Description	Assembly part number	Spare part number	Customer self repair
1	System fan module	381458-001	382109-001	Yes
2	Processor heatsink/cooling fan assembly	379265-001	382110-001	No
3	Processor			
	a) Intel® Celeron® D 2.8-GHz/533-MHz FSB/256-KB L2 cache	367744-001	382232-001	No
	b) Intel® Pentium® 4 3.0-GHz/800-MHz FSB/1-MB L2 cache*	390592-001	366643-001	No
	c) Intel® Pentium® 4 3.2-GHz/800-MHz FSB/1-MB L2 cache*	384930-001	366644-001	No
	d) Intel® Pentium® 4 3.4-GHz/800-MHz FSB/1-MB L2 cache*	384931-001	367415-001	No
	e) Intel® Pentium® 4 3.2-GHz/800-MHz FSB/2-MB L2 cache*	391817-001	384786-001	No

8 HP ProLiant ML310 Generation 2 Server Maintenance and Service Guide

Item	Description	Assembly part number	Spare part number	Customer self repair
	d) Intel® Pentium® 4 3.4-GHz/800-MHz FSB/2-MB L2 cache*	398344-001	384787-001	No
4	Memory			
	a) 256-MB PC-3200 unbuffered DDR DIMM	326315-441	382202-001	Yes
	b) 512-MB PC-3200 unbuffered DDR DIMM*	326316-441	351657-005	Yes
	c) 1-GB PC-3200 unbuffered DDR DIMM*	326317-451	351658-001	Yes
	Boards			
5	System board with tray	326513-001	382202-001	Yes
6	Hot-plug SCSI hard drive backplane board	382118-001	385597-001	Yes
7	Hot-plug SATA hard drive backplane board	379271-001	382985-001	Yes
8	SCSI controller card	332541-001	366651-001	Yes
9	Power button/LED board	383680-001	385744-001	Yes
	Mass storage devices			
10	IDE CD-ROM drive (48X)	266072-001	288894-005	Yes
11	Non-hot-plug 36-GB SCSI hard drive	357014-001	372659-005	Yes
12	Non-hot-plug 80-GB SATA hard drive	332649-003	373315-001	Yes
	Power			
13	350-W power supply unit with cable assembly	377580-001	382097-001	Yes
14	3-V 200-mAh internal lithium battery for system board	-	234556-001	Yes
	Cable assembly			
15	IDE CD-ROM drive cable assembly*	385482-001	382972-001	Yes
16	SCSI drive cable assembly*	302377-001	384753-001	Yes
17	Non-hot-plug SATA cable assembly*	384735-001	389309-001	Yes
18	Hot-plug SATA/SAS cable assembly*	361316-009	386754-001	Yes
19	Power button/LED board cable assembly*	382630-001	382982-001	Yes
20	Front USB connector cable assembly*	382631-001	382984-001	Yes

Item	Description	Assembly part number	Spare part number	Customer self repair
21	Return kit*	-	382204-001	Yes

* Not shown

Removal and replacement procedures

In this section

Required tools.....	11
Safety considerations.....	12
Preparation procedures.....	15
Bezel.....	17
Hot-plug SCSI hard drive.....	17
Hot-plug SATA/SAS hard drive.....	18
Access panel.....	20
PCI expansion board.....	21
Battery.....	21
DIMM.....	23
Air baffle.....	25
Fan.....	25
Power supply.....	27
Processor assembly.....	27
Diskette drive.....	30
CD-ROM/DVD-ROM drive.....	31
Installing a full-height tape drive option.....	32
Full-height tape drive.....	34
Power button/LED board.....	35
Hard drive (non-hot-plug).....	37
Hot-plug SCSI backplane.....	38
Hot-plug SATA or SAS backplane.....	40
System board.....	42

Required tools

You need the following items for some procedures:

- T-15 Torx screwdriver
- HP Insight Diagnostics software ("Array Diagnostic Utility" on page [49](#), "HP Insight Diagnostics" on page [50](#))

Safety considerations

Before performing service procedures, review all the safety information.

Preventing electrostatic discharge

To prevent damaging the system, be aware of the precautions you need to follow when setting up the system or handling parts. A discharge of static electricity from a finger or other conductor may damage system boards or other static-sensitive devices. This type of damage may reduce the life expectancy of the device.

To prevent electrostatic damage:

- Avoid hand contact by transporting and storing products in static-safe containers.
- Keep electrostatic-sensitive parts in their containers until they arrive at static-free workstations.
- Place parts on a grounded surface before removing them from their containers.
- Avoid touching pins, leads, or circuitry.
- Always be properly grounded when touching a static-sensitive component or assembly.

Server warnings and cautions

Before installing a server, be sure that you understand the following warnings and cautions.

 **WARNING:** To reduce the risk of electric shock or damage to the equipment:

- Do not disable the power cord grounding plug. The grounding plug is an important safety feature.
- Plug the power cord into a grounded (earthed) electrical outlet that is easily accessible at all times.
- Unplug the power cord from the power supply to disconnect power to the equipment.
- Do not route the power cord where it can be walked on or pinched by items placed against it. Pay particular attention to the plug, electrical outlet, and the point where the cord extends from the server.

⚠ WARNING: To reduce the risk of personal injury from hot surfaces, allow the drives and the internal system components to cool before touching them.

⚠ CAUTION: Do not operate the server for long periods with the access panel open or removed. Operating the server in this manner results in improper airflow and improper cooling that can lead to thermal damage.

Warnings and cautions

⚠ WARNING: To reduce the risk of personal injury or damage to the equipment, be sure that:

- The leveling jacks are extended to the floor.
- The full weight of the rack rests on the leveling jacks.
- The stabilizing feet are attached to the rack if it is a single-rack installation.
- The racks are coupled together in multiple-rack installations.
- Only one component is extended at a time. A rack may become unstable if more than one component is extended for any reason.

⚠ WARNING: To reduce the risk of personal injury or equipment damage when unloading a rack:

- At least two people are needed to safely unload the rack from the pallet. An empty 42U rack can weigh as much as 115 kg (253 lb), can stand more than 2.1 m (7 ft) tall, and may become unstable when being moved on its casters.
- Never stand in front of the rack when it is rolling down the ramp from the pallet. Always handle the rack from both sides.

 **WARNING:** When installing a server in a telco rack, be sure that the rack frame is adequately secured to the top and bottom of the building structure.

 **WARNING:** This server is very heavy. To reduce the risk of personal injury or damage to the equipment:

- Observe local occupational health and safety requirements and guidelines for manual material handling.
- Get help to lift and stabilize the product during installation or removal, especially when the product is not fastened to the rails. When the server weighs more than 22.5 kg (50 lb), at least two people must lift the server into the rack together. A third person may be required to help align the server if the server is installed higher than chest level.
- Use caution when installing the server in or removing the server from the rack; it is unstable when not fastened to the rails.

 **WARNING:** To reduce the risk of personal injury from hot surfaces, allow the drives and the internal system components to cool before touching them.

 **WARNING:** To reduce the risk of personal injury, electric shock, or damage to the equipment, remove the power cord to remove power from the server. The front panel Power On/Standby button does not completely shut off system power. Portions of the power supply and some internal circuitry remain active until AC power is removed.

 **CAUTION:** Protect the server from power fluctuations and temporary interruptions with a regulating uninterruptible power supply (UPS). This device protects the hardware from damage caused by power surges and voltage spikes and keeps the system in operation during a power failure.

 **CAUTION:** Do not operate the server for long periods with the access panel open or removed. Operating the server in this manner results in improper airflow and improper cooling that can lead to thermal damage.

Preparation procedures

List of topics:

Powering down the server	15
Removing the server from the rack	15
Unlocking the bezel	16

Powering down the server

 **WARNING:** To reduce the risk of personal injury, electric shock, or damage to the equipment, remove the power cord to remove power from the server. The front panel Power On/Standby button does not completely shut off system power. Portions of the power supply and some internal circuitry remain active until AC power is removed.

 **IMPORTANT:** If installing a hot-plug device, it is not necessary to power down the server.

1. Shut down the OS as directed by the OS documentation.
2. Press the Power On/Standby button to place the server in standby mode. When the server enters standby power mode, the system power LED changes to amber.
3. Disconnect the power cords.

The system is now without power.

Removing the server from the rack

If the server is installed with an optional rack enabling kit, remove the server from the rack before beginning any service procedures.

1. Power down the server ("Powering down the server" on page [15](#)).

2. Disconnect peripheral device and power cables.
3. Release the server from the tray.
4. Extend the server from the rack.
5. Remove the server from the tray and place it on a flat work surface.

Unlocking the bezel

Unlock and open the bezel before accessing the hard drive cage and before removing the access panel. Close and lock the bezel during normal server operations to ensure proper cooling airflow.

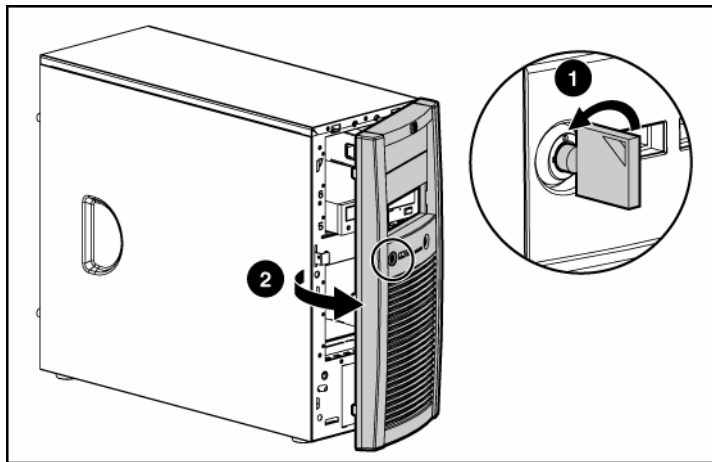

Bezel

To remove the component:

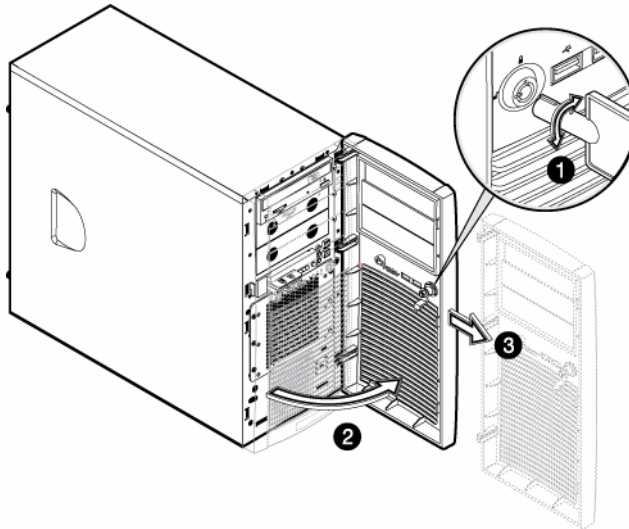

To replace the component, reverse the removal procedure.

Hot-plug SCSI hard drive

△ CAUTION: To prevent improper cooling and thermal damage, do not operate the server unless all bays are populated with either a component or a blank.

To remove the component:

1. Determine the status of the hard drive from the hot-plug hard drive LEDs ("Hot-plug SCSI hard drive LED combinations" on page [63](#), "Hot-plug SCSI hard drive LEDs" on page [62](#)).
2. Unlock and open the bezel ("Unlocking the bezel" on page [16](#)).

3. Remove the hard drive.

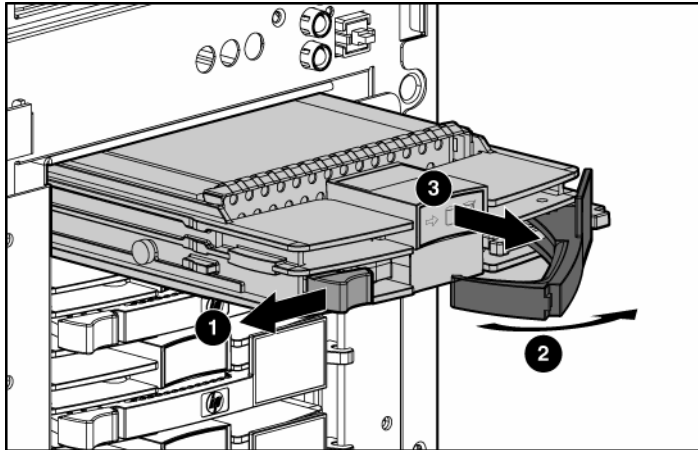

To replace the component:

1. Slide the drive into the cage until it clicks, locking the drive into place.
2. Close the lever.



IMPORTANT: When the drive is inserted, the drive LEDs flash for 2 seconds to indicate that the drive is seated properly and receiving power.

3. As the drive begins to spin, be sure that the drive LEDs illuminate one at a time and then turn off together to indicate that the system has recognized the new drive.

In fault-tolerant configurations, allow the replacement drive to be reconstructed automatically with data from the other drives. While reconstruction is in progress, the online LED flashes.

Hot-plug SATA/SAS hard drive

Hot-plug SATA and hot-plug SAS hard drives can be used interchangeably when a SAS controller is installed. The embedded SATA controller supports only SATA drives.

CAUTION: To prevent improper cooling and thermal damage, do not operate the server unless all bays are populated with either a component or a blank.

To remove the component:

1. Determine the status of the hard drive from the hot-plug hard drive LEDs ("Hot-plug SCSI hard drive LED combinations" on page [63](#), "Hot-plug SCSI hard drive LEDs" on page [62](#)).

IMPORTANT: When hot-plug SATA hard drives are installed, SATA LED functionality and full SATA hot-plug capability are not supported with the embedded controller. For full LED and hot-plug support, an optional SATA RAID or SAS controller must be installed.

2. Unlock and open the bezel ("Unlocking the bezel" on page [16](#)).
3. Remove the hard drive.

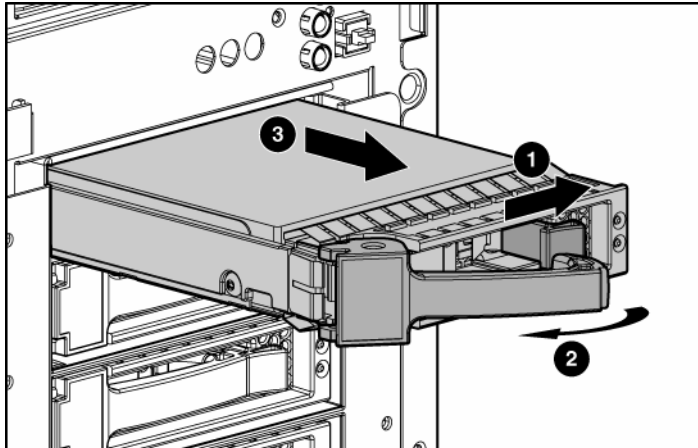

To replace the component:

1. Slide the drive into the cage until it clicks, locking the drive into place.
2. Close the lever.

IMPORTANT: When the drive is inserted, the drive LEDs flash for 2 seconds to indicate that the drive is seated properly and receiving power.

3. As the drive begins to spin, be sure that the drive LEDs illuminate one at a time and then turn off together to indicate that the system has recognized the new drive.

In fault-tolerant configurations, allow the replacement drive to be reconstructed automatically with data from the other drives. While reconstruction is in progress, the online LED flashes.

 **NOTE:** The SATA RAID feature supports the use of two hard drives. When the feature is enabled on a system with three or more drives installed, the system only recognizes the two drives with the lowest drive numbers.

Access panel

 **WARNING:** To reduce the risk of personal injury from hot surfaces, allow the drives and the internal system components to cool before touching them.

 **CAUTION:** Do not operate the server for long periods with the access panel open or removed. Operating the server in this manner results in improper airflow and improper cooling that can lead to thermal damage.

1. Power down the server ("Powering down the server" on page [15](#)).
2. Remove the bezel ("Bezel" on page [17](#)).
3. Remove the access panel.

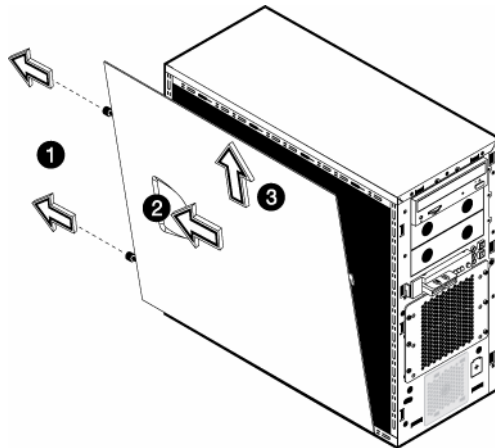

To replace the component, reverse the removal procedure.

PCI expansion board

To remove the component:

1. Power down the server ("Powering down the server" on page [15](#)).
2. Remove the bezel ("Bezel" on page [17](#)).
3. Remove the access panel ("Access panel" on page [20](#)).
4. Remove the expansion board from the slot.

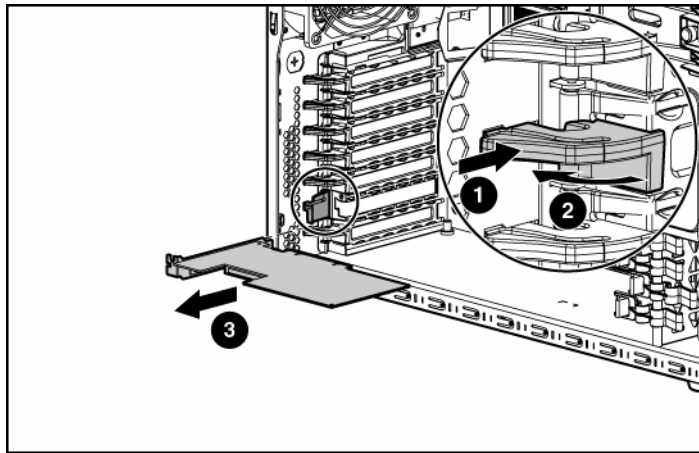

To replace the component, reverse the removal procedure.

Battery

If the server no longer automatically displays the correct date and time, you may need to replace the battery that provides power to the real-time clock. Under normal use, battery life is 5 to 10 years.

⚠ WARNING: The computer contains an internal lithium manganese dioxide, a vanadium pentoxide, or an alkaline battery pack. A risk of fire and burns exists if the battery pack is not properly handled. To reduce the risk of personal injury:

- Do not attempt to recharge the battery.
- Do not expose the battery to temperatures higher than 60°C (140°F).
- Do not disassemble, crush, puncture, short external contacts, or dispose of in fire or water.
- Replace only with the spare designated for this product.

To remove the component:

1. Power down the server ("Powering down the server" on page [15](#)).
2. Remove the bezel ("Bezel" on page [17](#)).
3. Remove the access panel ("Access panel" on page [20](#)).
4. Remove the battery.

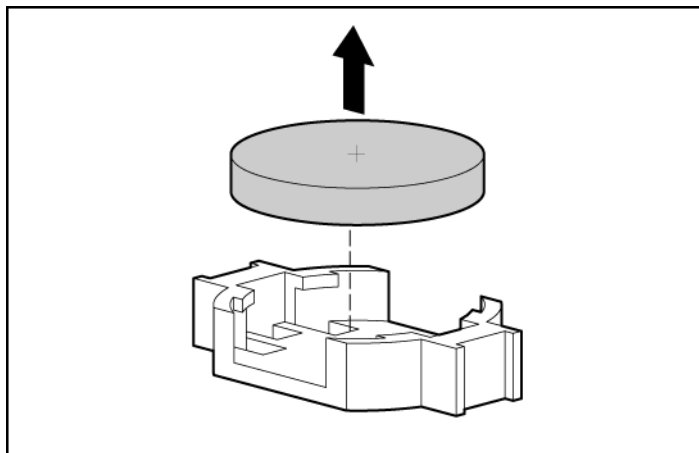

To replace the component, reverse the removal procedure.

 **IMPORTANT:** After replacing the battery, the server is automatically configured with the default settings. The user can update these settings using RBSU.

For more information about battery replacement or proper disposal, contact an authorized reseller or an authorized service provider.

DIMM

You can expand server memory by installing PC-3200 DDR SDRAM DIMMs with Advanced ECC. The system supports up to four DIMMs for a maximum of 4 GB.

Refer to "System Board Components (on page [57](#))" for DIMM slot locations and bank assignments.

To remove the component:

1. Power down the server ("Powering down the server" on page [15](#)).
2. Remove the bezel ("Bezel" on page [17](#)).
3. Remove the access panel ("Access panel" on page [20](#)).
4. Remove the DIMM.

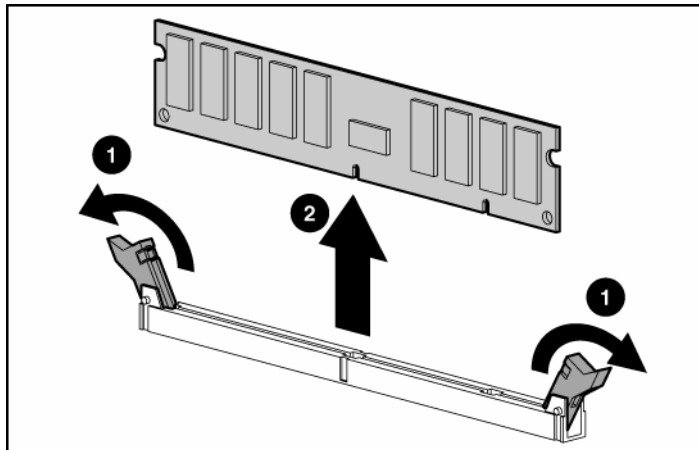

 **IMPORTANT:** DIMMs do not seat fully if turned the wrong way.

To replace the component, reverse the removal procedure.

For DIMM configuration information, refer to DIMM installation guidelines (on page [24](#)).

DIMM installation guidelines

Observe the following guidelines when installing additional memory:

- DIMMs installed in the server must be Unbuffered DDR DRAM, 2.5 volts, 64 bits wide, and ECC.
- If only a single DIMM is installed, it must be installed in slot 1A.
- All DIMMs installed must be the same speed.

BIOS detects the DIMM population and sets the system as follows:

- Single-channel mode: DIMMs installed in one channel only.
- Dual-channel asymmetric mode: DIMMs installed in both channels but of unequal capacities per channel.
- Dual-channel interleaved mode: DIMMs installed in both channels with equal channel capacities.

The following table lists some, but not all, possible configurations. For best performance, HP recommends dual-channel interleaved mode configurations.

Slot 1A	Slot 2A	Slot 3B	Slot 4B	Total memory	Mode
128 MB	—	—	—	128 MB	Single-channel
128 MB	—	128 MB	—	256 MB	Dual-channel interleaved
128 MB	128 MB	128 MB	—	384 MB	Dual-channel asymmetric
128 MB	128 MB	128 MB	128 MB	512 MB	Dual-channel interleaved
256 MB	—	—	—	256 MB	Single-channel
256 MB	—	256 MB	—	512 MB	Dual-channel interleaved
512 MB	—	—	—	512 MB	Single-channel
512 MB	—	512 MB	—	1 GB	Dual-channel interleaved
1 GB	—	—	—	1 GB	Single-channel
1 GB	—	1 GB	—	2 GB	Dual-channel interleaved
1 GB	1 GB	1 GB	—	3 GB	Dual-channel asymmetric

Slot 1A	Slot 2A	Slot 3B	Slot 4B	Total memory	Mode
1 GB	1 GB	1 GB	1 GB	4 GB	Dual-channel interleaved

Air baffle

To remove the component:

1. Power down the server ("Powering down the server" on page [15](#)).
2. Remove the bezel ("Bezel" on page [17](#)).
3. Remove the access panel ("Access panel" on page [20](#)).
4. Remove the air baffle.

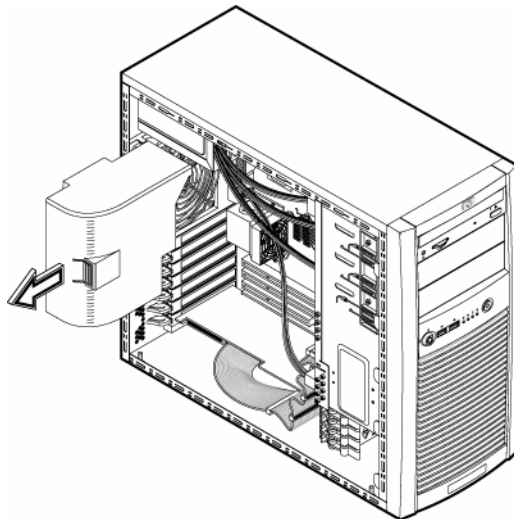

To replace the component, reverse the removal procedure.

Fan

To remove the component:

1. Power down the server ("Powering down the server" on page [15](#)).

2. Remove the bezel ("Bezel" on page [17](#)).
3. Remove the access panel ("Access panel" on page [20](#)).
4. Remove the air baffle ("Air baffle" on page [25](#)).
5. Remove the fan assembly.

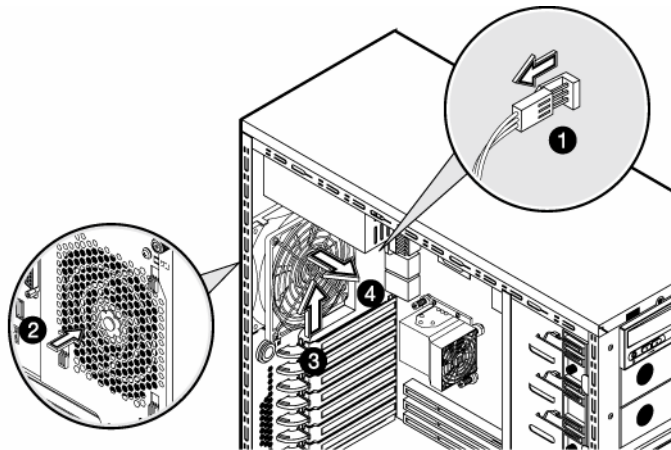

6. Remove the fan from the holder.

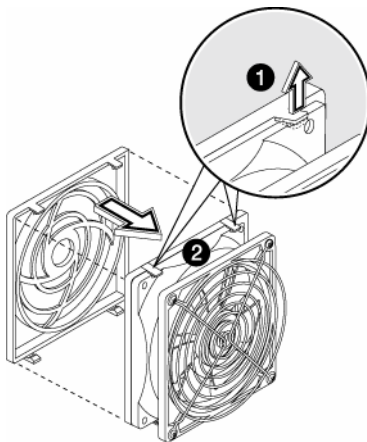

To replace the component, reverse the removal procedure.

Power supply

To remove the component:

1. Power down the server ("Powering down the server" on page [15](#)).
2. Remove the bezel ("Bezel" on page [17](#)).
3. Remove the access panel ("Access panel" on page [20](#)).
4. Remove the air baffle ("Air baffle" on page [25](#)).
5. Disconnect the power and data cables.
6. Remove the power supply.

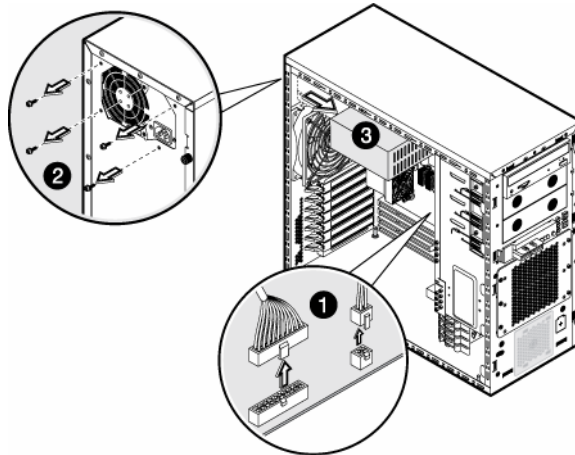

To replace the component, reverse the removal procedure.

Processor assembly

 **IMPORTANT:** To avoid damage to the processor and system board, only authorized technicians trained by HP should attempt to replace or install the processor in this server.

To remove the component:

1. Power down the server ("Powering down the server" on page [15](#)).

2. Remove the bezel ("Bezel" on page [17](#)).
3. Remove the access panel ("Access panel" on page [20](#)).
4. Disconnect the fan cable from the system board.
5. Remove the heatsink fan assembly

△ **CAUTION:** Heatsink retaining screws should be removed in diagonally opposite pairs (in an "X" pattern).

△ **CAUTION:** The pins on the processor socket are very fragile. Any damage to them may require replacing the system board.

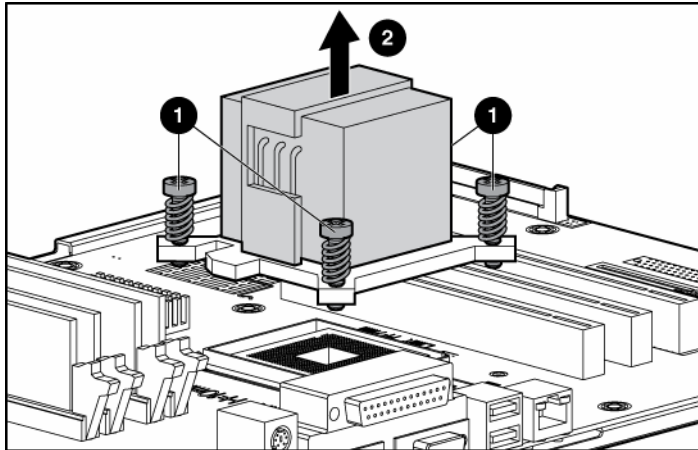

6. Remove the processor.

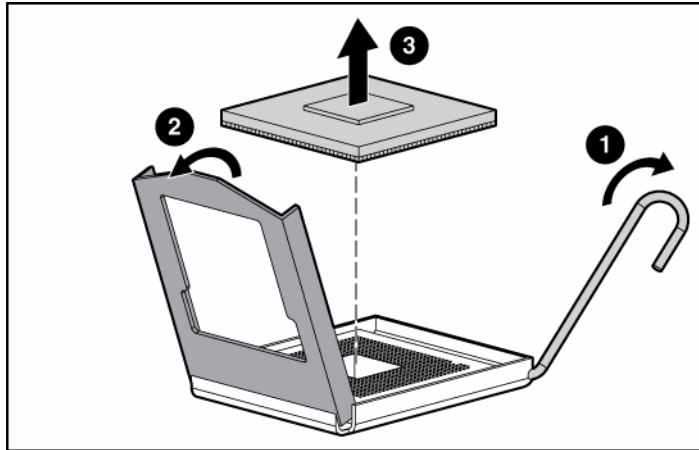

To replace the component:

1. Install the processor.

CAUTION: To prevent possible server malfunction or damage to the equipment, be sure to align the processor pins with the corresponding holes in the socket.

CAUTION: To prevent possible server malfunction or damage to the equipment, be sure to completely close the processor locking lever.

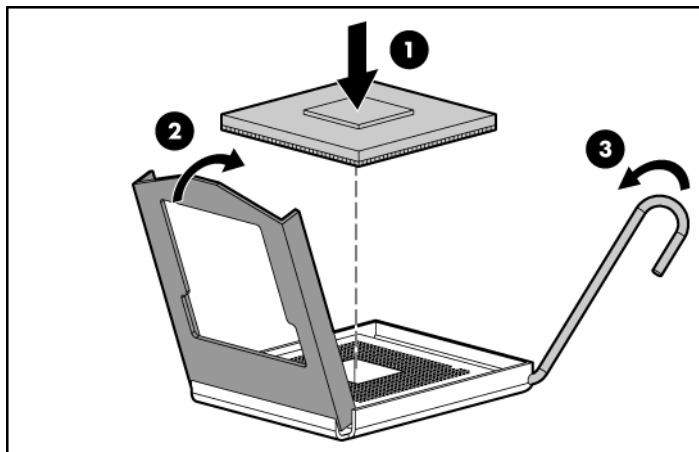

2. Prepare the heatsink for installation:
 - If reusing the heatsink, clean the bottom of the heatsink with the provided alcohol pad, then apply a thin layer of thermal grease to the top of the processor.
 - If installing a new heatsink, remove the protective covering.
3. Install the heatsink fan assembly.

△ CAUTION: Heatsink retaining screws should be tightened in diagonally opposite pairs (in an "X" pattern).

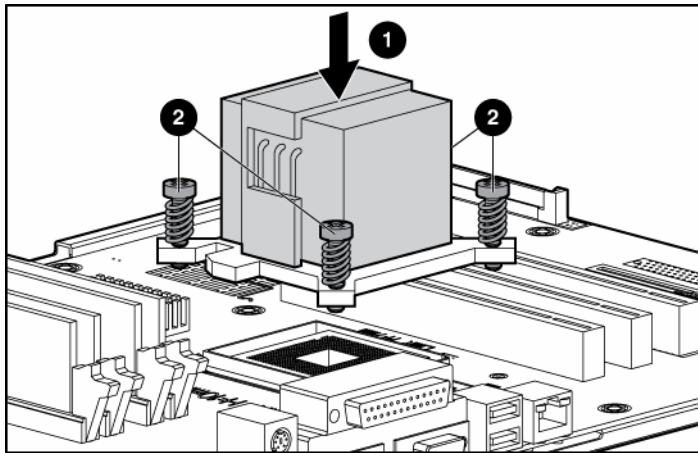

4. Connect the fan cable to the system board.
5. Install the access panel.
6. Install the bezel.

Diskette drive

△ CAUTION: To prevent improper cooling and thermal damage, do not operate the server unless all bays are populated with either a component or a blank.

To remove the component:

1. Power down the server ("Powering down the server" on page [15](#)).
2. Remove the bezel ("Bezel" on page [17](#)).

3. Remove the access panel ("Access panel" on page [20](#)).
4. Disconnect the power and data cables.
5. Remove the diskette drive.

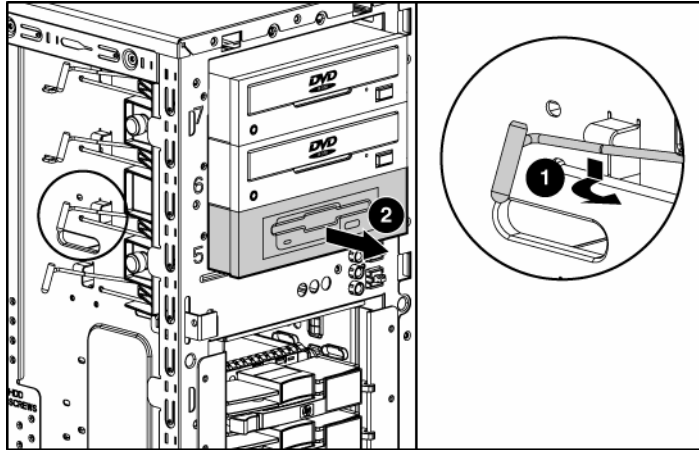

To replace the component, reverse the removal procedure.

CD-ROM/DVD-ROM drive

CAUTION: To prevent improper cooling and thermal damage, do not operate the server unless all bays are populated with either a component or a blank.

To remove the component:

1. Power down the server ("Powering down the server" on page [15](#)).
2. Remove the bezel ("Bezel" on page [17](#)).
3. Remove the access panel ("Access panel" on page [20](#)).
4. Disconnect the power and data cables.

5. Remove the CD-ROM or DVD-ROM drive.

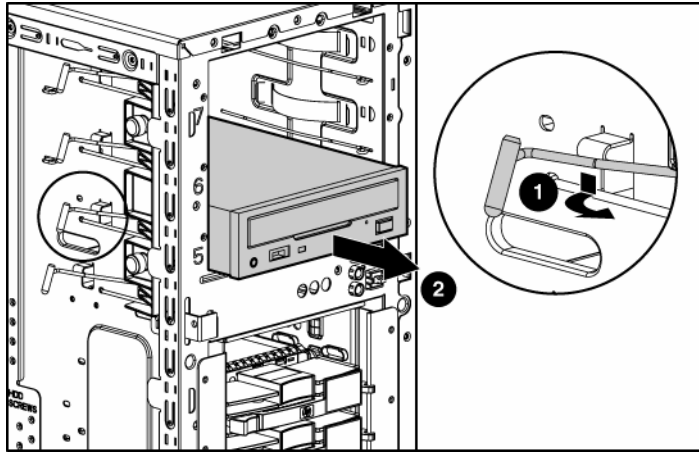

To replace the component, reverse the removal procedure.

Installing a full-height tape drive option

1. Power down the server ("Powering down the server" on page [15](#)).
2. Remove the bezel ("Bezel" on page [17](#), "Server warnings and cautions" on page [12](#)).
3. Remove the access panel ("Access panel" on page [20](#)).
4. Remove the media bay blanks ("Front panel components" on page [53](#)).

5. Use a screwdriver to disengage the two wire supports inside the full-height drive bays.

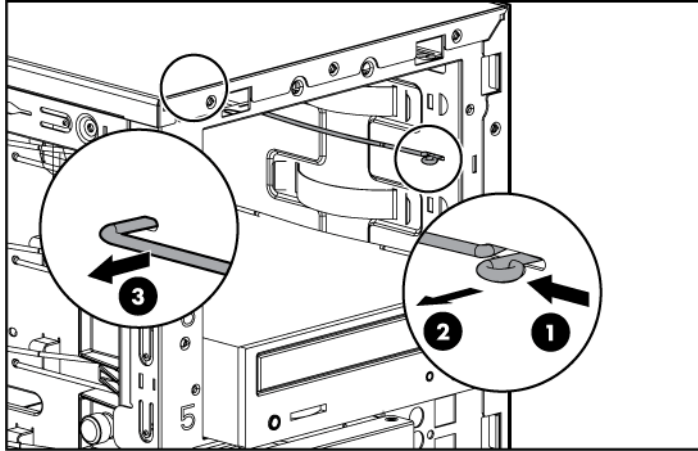

6. Install the tape drive.

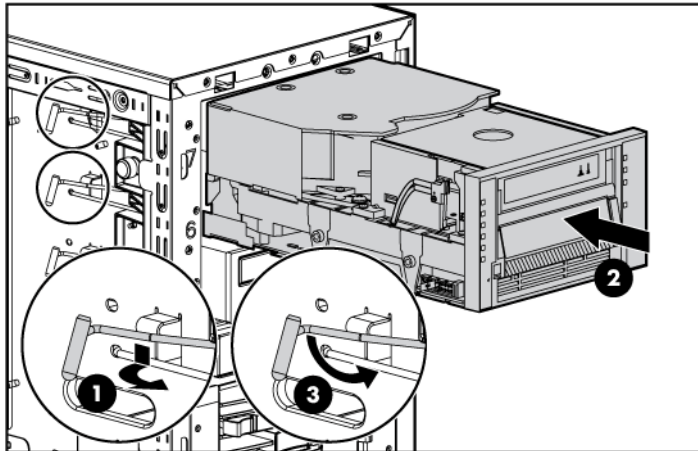

7. Install the retaining screw.

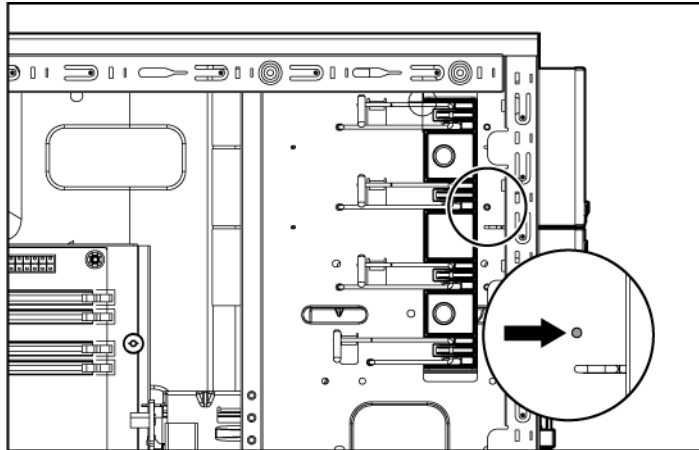

 **IMPORTANT:** HP recommends installing the tape drive on a separate SCSI cable to avoid a decrease in performance on other SCSI devices.

8. Connect the data and power cables to the back of the tape drive.
9. Connect the data cable into a SCSI controller channel ("System board components" on page [57](#)).
10. Remove the applicable bezel blanks from the bezel ("Front panel components" on page [53](#)).
11. Install the bezel ("Bezel" on page [17](#), "Server warnings and cautions" on page [12](#)).
12. Replace the access panel ("Access panel" on page [20](#)).

Full-height tape drive

 **CAUTION:** To prevent improper cooling and thermal damage, do not operate the server unless all bays are populated with either a component or a blank.

To remove the component:

1. Power down the server ("Powering down the server" on page [15](#)).

2. Remove the bezel ("Bezel" on page [17](#)).
3. Remove the access panel ("Access panel" on page [20](#)).
4. Disconnect the power and data cables.
5. Remove the tape drive.

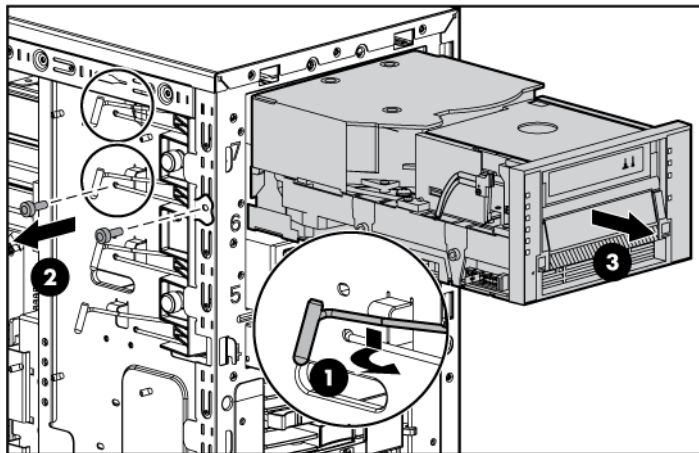

To replace the component, reverse the removal procedure.

Power button/LED board

To remove the component:

1. Power down the server ("Powering down the server" on page [15](#)).
2. Remove the bezel ("Bezel" on page [17](#)).
3. Remove the access panel ("Access panel" on page [20](#)).
4. Disconnect the power and data cables.

5. Remove the front panel assembly.

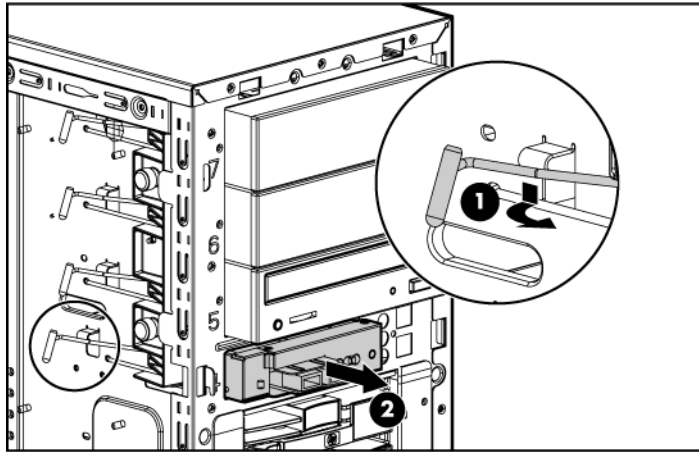

6. Remove the power button/LED board.

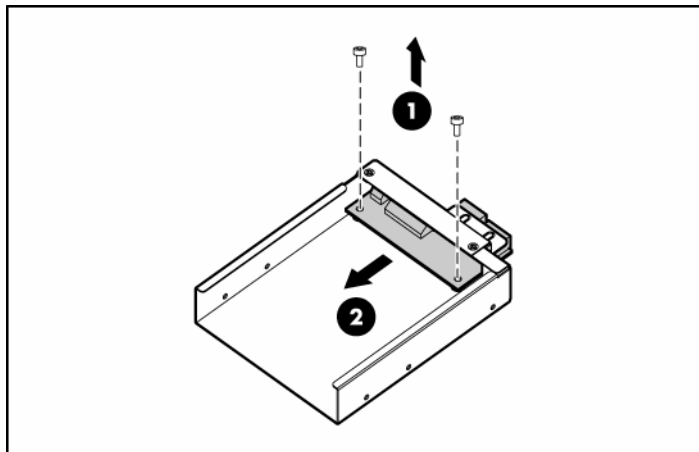

To replace the component, reverse the removal procedure.

Hard drive (non-hot-plug)

This procedure applies to non hot-plug drives only. If the server is equipped with hot-plug hard drives, refer to the hot-plug hard drive removal procedures ("Hot-plug SATA/SAS hard drive" on page [18](#), "Hot-plug SCSI hard drive" on page [17](#)).

To remove the component:

1. Power down the server ("Powering down the server" on page [15](#)).
2. Remove the bezel ("Bezel" on page [17](#)).
3. Remove the access panel ("Access panel" on page [20](#)).
4. Disconnect the power and data cables.
5. Remove the hard drive cage.

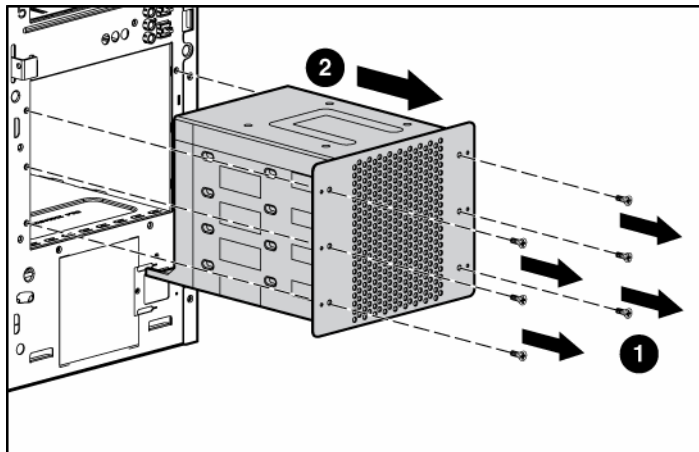

6. Remove the hard drive.

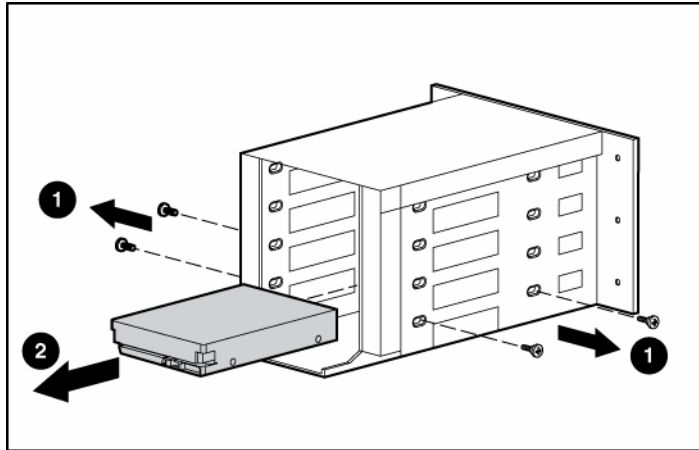

To replace the component, reverse the removal procedure.

Hot-plug SCSI backplane

To remove the component:

1. Power down the server ("Powering down the server" on page [15](#)).
2. Remove the bezel ("Bezel" on page [17](#)).
3. Remove the access panel ("Access panel" on page [20](#)).
4. Remove all hot-plug hard drives ("Hot-plug SATA/SAS hard drive" on page [18](#), "Hot-plug SCSI hard drive" on page [17](#)).
5. Disconnect the power and data cables.

6. Remove the hard drive cage.

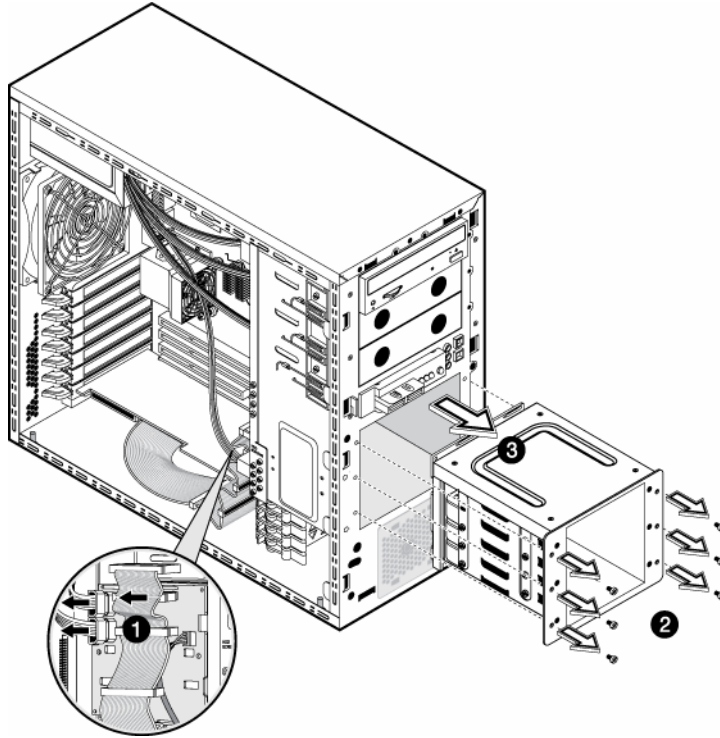

7. Remove the SCSI backplane.

 **NOTE:** If replacing only the hard drive cage, retain the backplane for use with the replacement hard drive cage.

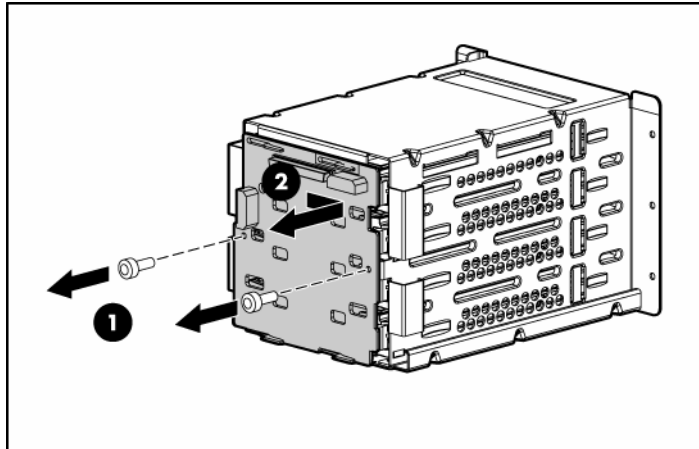

To replace the component, reverse the removal procedure.

Hot-plug SATA or SAS backplane

To remove the component:

1. Power down the server ("Powering down the server" on page [15](#)).
2. Remove the bezel ("Bezel" on page [17](#)).
3. Remove the access panel ("Access panel" on page [20](#)).
4. Remove all hot-plug hard drives ("Hot-plug SATA/SAS hard drive" on page [18](#), "Hot-plug SCSI hard drive" on page [17](#)).
5. Disconnect the power and data cables.

6. Remove the hard drive cage.

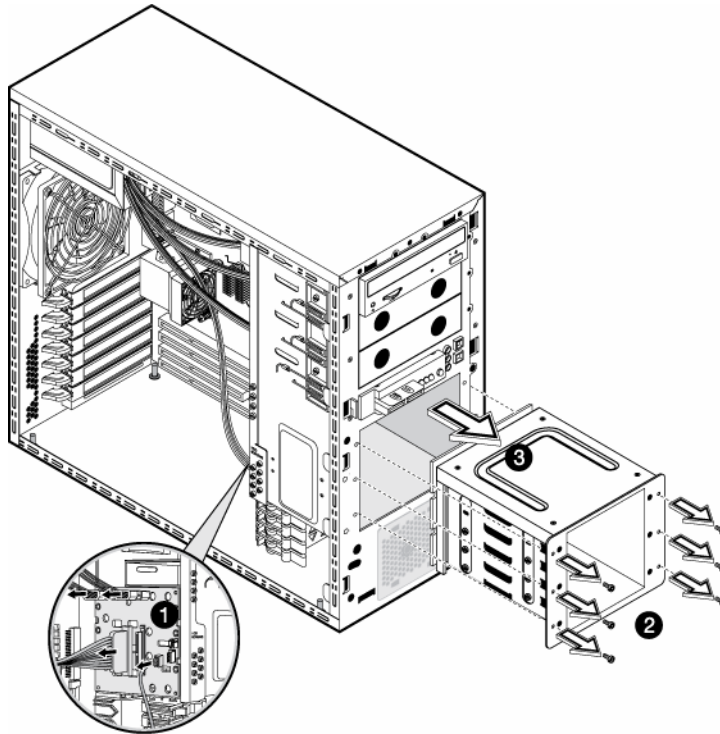

7. Remove the SATA or SAS backplane.

 **NOTE:** If replacing only the hard drive cage, retain the backplane for use with the replacement hard drive cage.

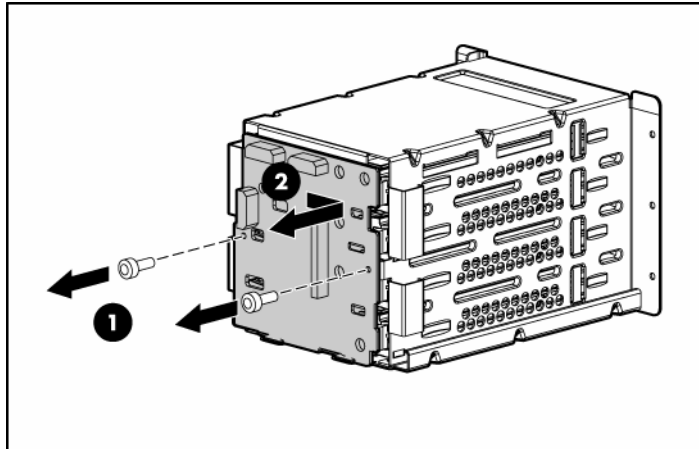

To replace the component, reverse the removal procedure.

System board

To remove the component:

1. Power down the server ("Powering down the server" on page [15](#)).
2. Remove the bezel ("Bezel" on page [17](#)).
3. Remove the access panel ("Access panel" on page [20](#)).
4. Remove the air baffle ("Air baffle" on page [25](#)).
5. Disconnect all cabling.

6. Remove the system board.

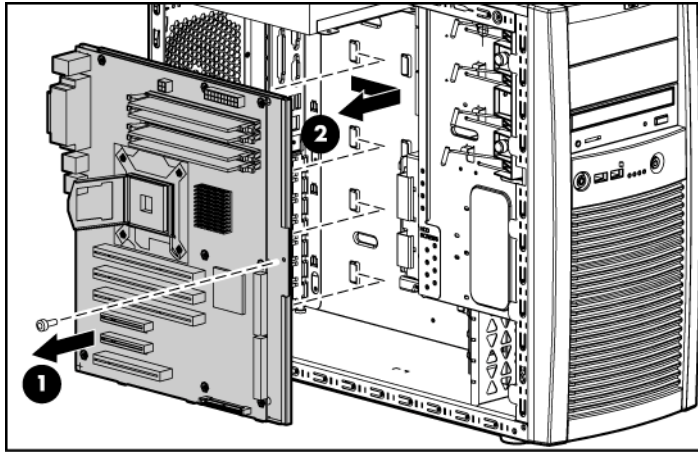

To replace the component, reverse the removal procedure.

After you replace the system board, you must re-enter the server serial number and the product ID.

1. During the server startup sequence, press the **F9** key to access RBSU.
2. Select the **Advanced Options** menu.
3. Select **Serial Number**. The following warning is displayed:
Warning: The serial number should **ONLY** be modified by qualified service personnel. This value should always match the serial number located on the chassis.
4. Press the **Enter** key to clear the warning.
5. Enter the serial number.
6. Select **Product ID**. The following warning is displayed.
Warning: The Product ID should **ONLY** be modified by qualified service personnel. This value should always match the Product ID located on the chassis.
7. Enter the product ID and press the **Enter** key.
8. Press the **Esc** key to close the menu.
9. Press the **Esc** key to exit RBSU.

10. Press the **F10** key to confirm exiting RBSU. The server will automatically reboot.

Server cabling

In this section

Hot-plug SCSI cabling.....	45
Hot-plug SATA cabling.....	46
Non-hot-plug SCSI cabling	46
Non-hot-plug SATA cabling	47
SAS cabling	48

Hot-plug SCSI cabling

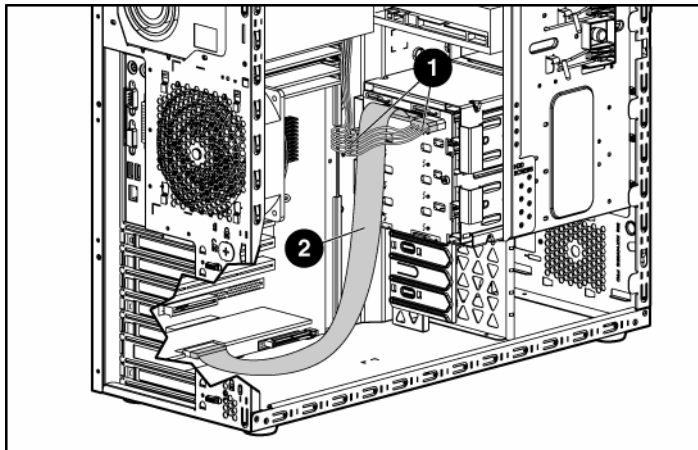

Item	Cable description
1	Power cable
2	SCSI cable

Hot-plug SATA cabling

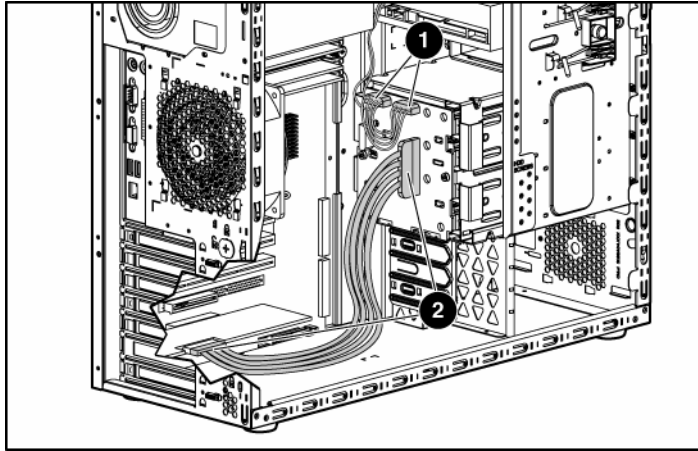

Item	Cable description
1	Power cable
2	SATA cable

Non-hot-plug SCSI cabling

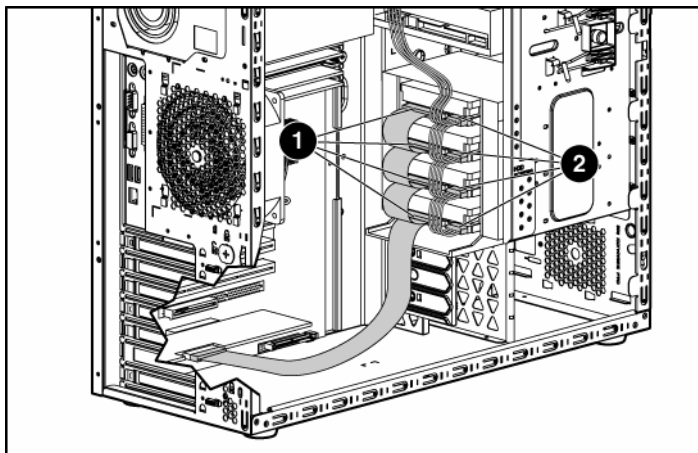

Item	Cable description
1	SCSI cable
2	Power cable

Non-hot-plug SATA cabling

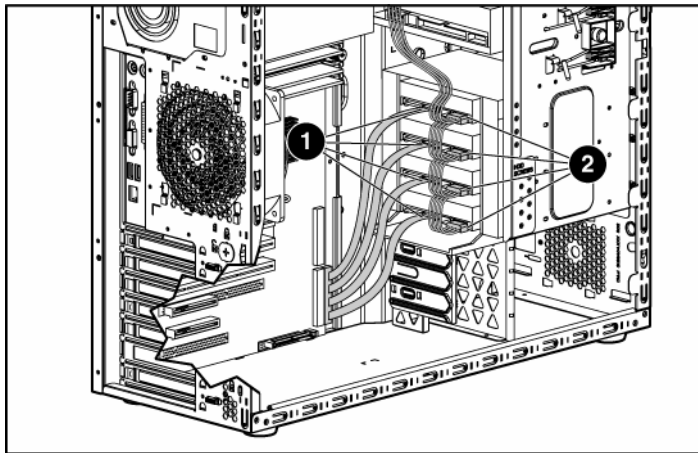

Item	Cable description
1	SATA cable
2	Power cable

SAS cabling

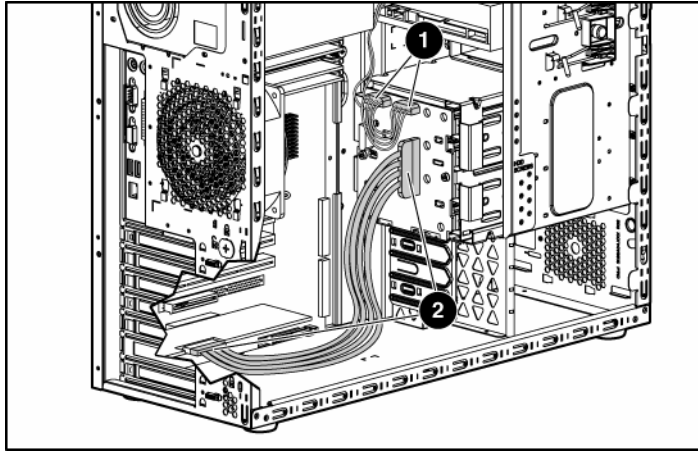

Item	Cable description
1	Power cable
2	SAS cable

Diagnostic tools

In this section

Survey Utility	49
Array Diagnostic Utility	49
HP Insight Diagnostics	50
Integrated Management Log	50

Survey Utility

Survey Utility, a feature within HP Insight Diagnostics ("Array Diagnostic Utility" on page [49](#), on page [50](#)), gathers critical hardware and software information on ProLiant servers.

This utility supports operating systems that may not be supported by the server. For operating systems supported by the server, refer to the HP website (<http://www.hp.com/go/supportos>).

If a significant change occurs between data-gathering intervals, the Survey Utility marks the previous information and overwrites the Survey text files to reflect the latest changes in the configuration.

Survey Utility is installed with every SmartStart-assisted installation or can be installed through the HP PSP.

Array Diagnostic Utility

ADU is tool that collects information about array controllers and generates a list of detected problems. ADU can be accessed from the SmartStart CD or downloaded from the HP website (<http://www.hp.com>).

HP Insight Diagnostics

HP Insight Diagnostics is a proactive server management tool, available in both offline and online versions, that provides diagnostics and troubleshooting capabilities to assist IT administrators who verify server installations, troubleshoot problems, and perform repair validation.

HP Insight Diagnostics Offline Edition performs various in-depth system and component testing while the OS is not running. To run this utility, launch the SmartStart CD.

HP Insight Diagnostics Online Edition is a web-based application that captures system configuration and other related data needed for effective server management. Available in Microsoft® Windows® and Linux versions, the utility helps to ensure proper system operation.

For more information or to download the utility, refer to the HP website (<http://www.hp.com/servers/diags>).

Integrated Management Log

The IML records hundreds of events and stores them in an easy-to-view form. The IML timestamps each event with 1-minute granularity.

You can view recorded events in the IML in several ways, including the following:

- From within HP SIM ("HP Insight Diagnostics" on page [50](#))
- From within Survey Utility (on page [49](#))
- From within operating system-specific IML viewers
 - For NetWare: IML Viewer
 - For Windows®: IML Viewer
 - For Linux: IML Viewer Application
- From within HP Insight Diagnostics ("Array Diagnostic Utility" on page [49](#), on page [50](#))

For more information, refer to the Management CD in the HP ProLiant Essentials Foundation Pack.

Server component identification

In this section

Front panel components.....	53
Front panel LEDs and buttons	54
Rear panel components.....	55
Rear panel LEDs and buttons	56
System board components	57
System board LEDs	59
System LEDs and internal health LED combinations	60
SCSI IDs.....	62
Hot-plug SCSI hard drive LEDs.....	62
Hot-plug SCSI hard drive LED combinations.....	63
Hot-plug SATA or SAS IDs.....	64
SATA or SAS hard drive LEDs	65
Fan locations.....	66

Front panel components

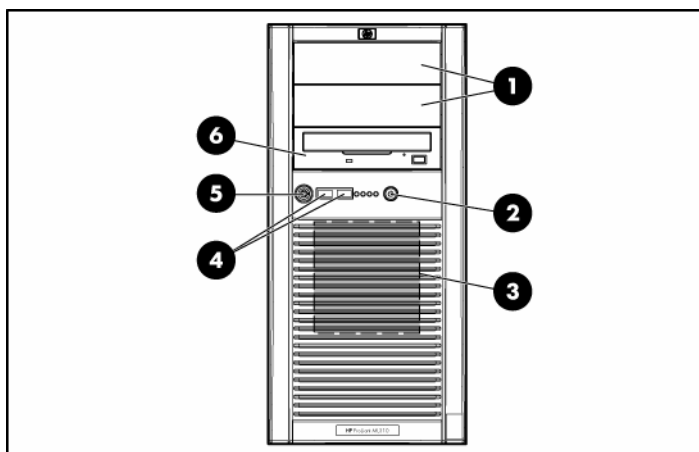

Item	Description
1	Media bays (bezel blanks)
2	Power On/Standby button
3	Hard drive bays
4	USB connectors (2)
5	Bezel lock
6	CD-ROM drive

Front panel LEDs and buttons

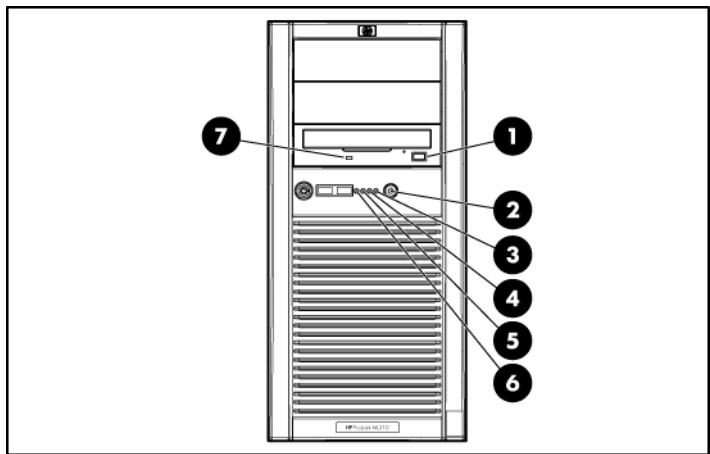

Item	Description	Status
1	CD-ROM drive ejector button	N/A
2	Power On/Standby button	N/A
3	Power on/Standby LED	Amber = System has AC power and is in standby mode Green = System has AC power and is functioning Off = System has no AC power

Item	Description	Status
4	Hard drive activity LED (for non-hot-plug)	Green = Hard drives are properly connected and functioning Off = No hard drive activity
5	NIC link/activity LED	Green = Linked to network Flashing green = Linked with activity on the network Off = No network connection
6	Internal system health LED	Green = Normal (system on) Amber = System health is degraded Red = System health is critical Off = Normal (system off)
7	CD-ROM drive indicator LED	N/A

Rear panel components

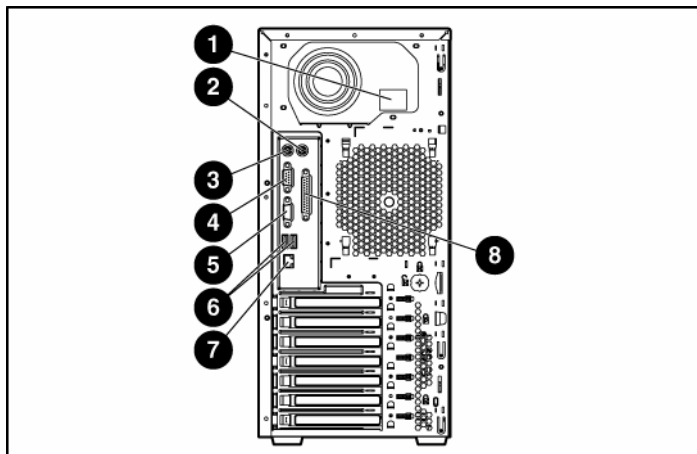

Item	Description
1	Power cord connector
2	Mouse connector
3	Keyboard connector

Item	Description
4	Serial connector
5	Video connector
6	USB connectors (2)
7	RJ-45 Ethernet connector
8	Parallel connector

Rear panel LEDs and buttons

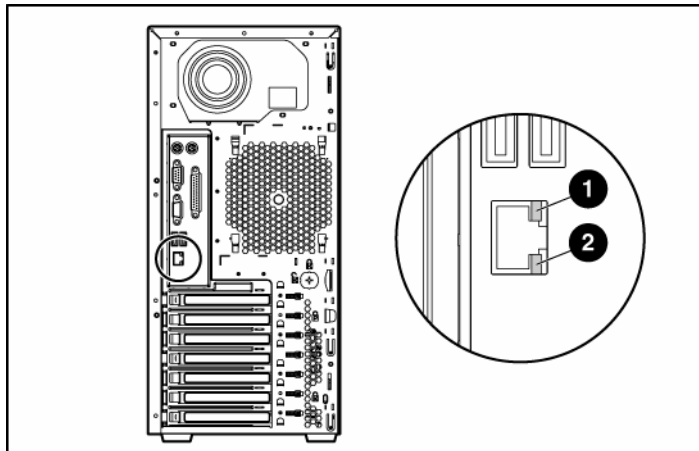

Item	Description	Status
1	10/100/1000 NIC link LED	On = Link Off = No link
2	10/100/1000 NIC standby LED	Flashing = Activity Off = No activity

System board components

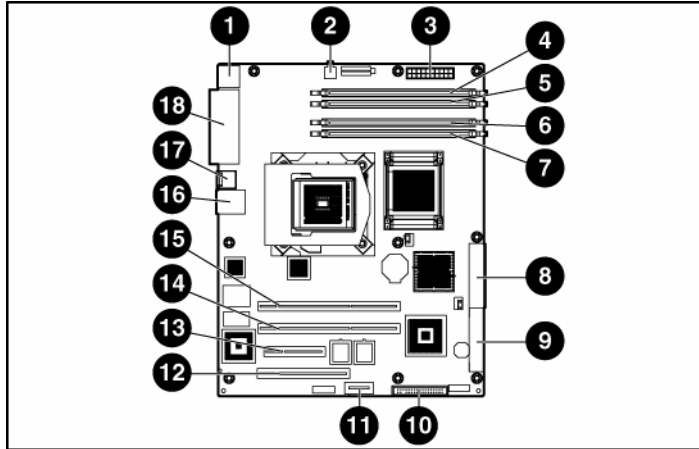

Item	Description	Item	Description
1	Mouse/keyboard connectors	10	Diskette drive connector
2	Processor power connector	11	RILOE connector
3	Power supply connector	12	32-bit PCI slot
4	DIMM slot 4 (B)	13	PCI Express x4 slot *
5	DIMM slot 3 (B)	14	PCI-X slot 2
6	DIMM slot 2 (A)	15	PCI-X slot 1
7	DIMM slot 1 (A)	16	RJ-45 connector
8	IDE connector	17	USB connectors (2)
9	SATA connector	18	Serial/video/parallel ports

* x8 PCI Express cards are supported, but will run at x4 speeds.

System maintenance switch

Position	Default	Function
S1	Off	Reserved

Position	Default	Function
S2	Off	Off = System configuration can be changed On = System configuration is locked
S3	Off	Reserved
S4	Off	Reserved
S5	Off	Off = No function On = Clears power-on password and administrator password
S6	Off	Off = Normal On = ROM treats system configuration as invalid

When the system maintenance switch position 6 is set to the On position, the system is prepared to erase all system configuration settings from both CMOS and NVRAM.

 **CAUTION:** Clearing CMOS and/or NVRAM deletes configuration information. Be sure to properly configure the server or data loss could occur.

System board LEDs

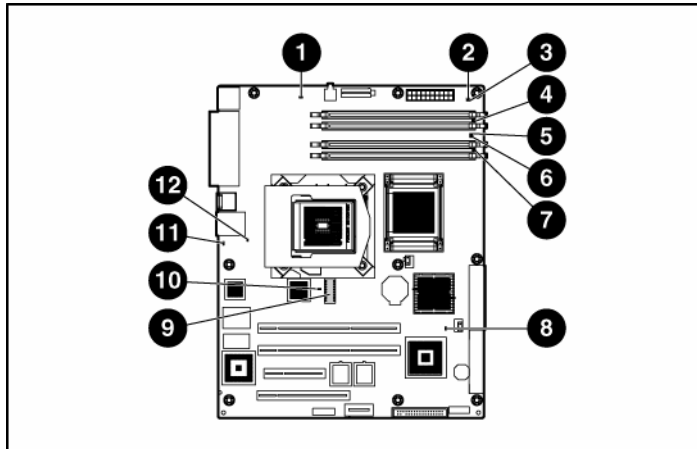

Item	LED description	Status
1	PPM failure	Off = Normal Amber = PPM failed or missing
2	Multibit error	Off = Normal Amber = A multibit error has occurred
3	Single bit error	Off = Normal Amber = Single bit error limit has been exceeded
4	DIMM 4 failure	Off = Normal Amber = DIMM 4 has failed or is missing
5	DIMM 3 failure	Off = Normal Amber = DIMM 3 has failed or is missing
6	DIMM 2 failure	Off = Normal Amber = DIMM 2 has failed or is missing
7	DIMM 1 failure	Off = Normal Amber = DIMM 1 has failed or is missing

Item	LED description	Status
8	Power good	Off = Normal Green = Power failed
9	Processor failure	Off = Normal Amber = Processor has failed
10	System temperature alert	Off = Normal Amber = System temperature has exceeded OS cautionary level
11	System fan failure	Off = Normal Amber = System fan has failed or is missing
12	Processor fan failure	Off = Normal Amber = Processor fan has failed or is missing

System LEDs and internal health LED combinations

When the internal health LED on the front panel illuminates either amber or red, the server is experiencing a health event. Combinations of illuminated system LEDs and the internal health LED indicate system status.



NOTE: The system management driver must be installed in order for the internal health LED to provide pre-failure and warranty conditions.

The front panel health LEDs indicate only the current hardware status. In some situations, HP SIM may report server status differently than the health LEDs because the software tracks more system attributes.

System LED and color	Internal health LED color	Status
Processor failure, socket X (Amber)	Red	One or more of the following conditions may exist: <ul style="list-style-type: none"> Processor in socket X has failed. Processor X is not installed in the socket. ROM detected a failed processor during POST.
	Amber	Processor in socket X is in a pre-failure condition.

System LED and color	Internal health LED color	Status
PPM failure, slot X (Amber)	Red	<ul style="list-style-type: none"> PPM in slot X has failed. PPM is not installed in slot X, but the corresponding processor is installed.
DIMM failure, slot X (Amber)	Red	<ul style="list-style-type: none"> DIMM in slot X has failed. DIMM has experienced a multi-bit error.
	Amber	<ul style="list-style-type: none"> DIMM in slot X has reached single-bit correctable error threshold. DIMM in slot X is in a pre-failure condition.
DIMM bank error (all slots in one bank, Amber)	Red	The bank is not populated entirely or DIMMs do not all match within the bank.
DIMM failure (all slots, Amber)	Red	<ul style="list-style-type: none"> No valid or usable memory is installed in the system. The banks are not populated in the correct order.
System temperature alert (Amber)	Red	System temperature has exceeded OS cautionary level or critical hardware level.
Fan (Amber)	Red	A required fan has failed.
	Amber	A redundant fan has failed.
Power supply backplane failure (Amber)	Red	The power supply backplane has failed.

SCSI IDs

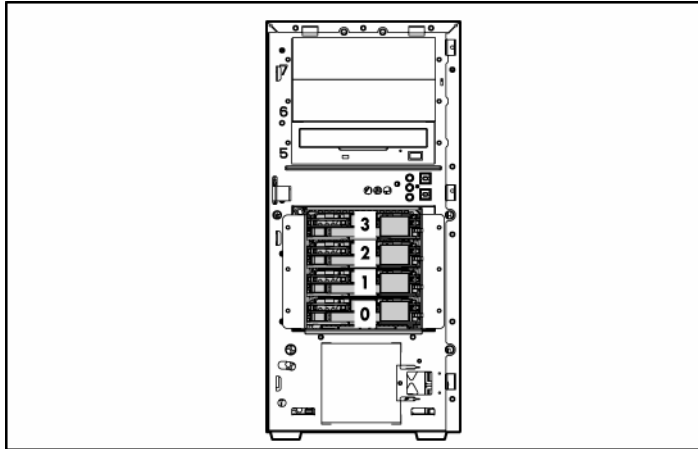

Hot-plug SCSI hard drive LEDs

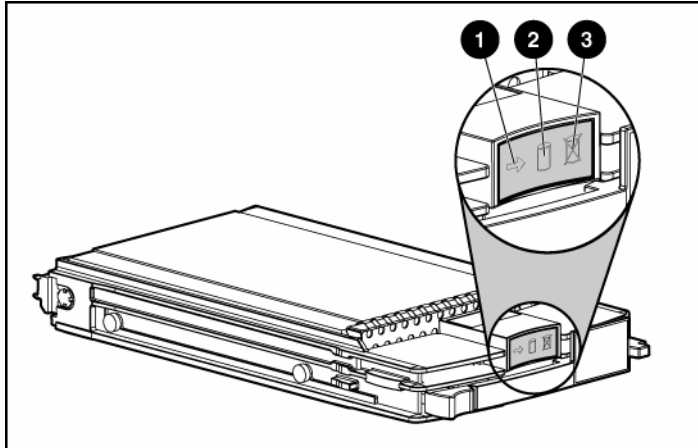

Item	LED description	Status
1	Activity status	On = Drive activity Flashing = High activity on the drive or drive is being configured as part of an array. Off = No drive activity
2	Online status	On = Drive is part of an array and is currently working. Flashing = Drive is actively online. Off = Drive is offline.
3	Fault status	On = Drive failure Flashing = Fault-process activity Off = No fault-process activity

Hot-plug SCSI hard drive LED combinations

Activity LED (1)	Online LED (2)	Fault LED (3)	Interpretation
On, off, or flashing	On or off	Flashing	A predictive failure alert has been received for this drive. Replace the drive as soon as possible.
On, off, or flashing	On	Off	The drive is online and is configured as part of an array. If the array is configured for fault tolerance and all other drives in the array are online, and a predictive failure alert is received or a drive capacity upgrade is in progress, you may replace the drive online.
On or flashing	Flashing	Off	Do not remove the drive. Removing a drive may terminate the current operation and cause data loss. The drive is rebuilding or undergoing capacity expansion.
On	Off	Off	Do not remove the drive. The drive is being accessed, but (1) it is not configured as part of an array; (2) it is a replacement drive and rebuild has not yet started; or (3) it is spinning up during the POST sequence.

Activity LED (1)	Online LED (2)	Fault LED (3)	Interpretation
Flashing	Flashing	Flashing	<p>Do not remove the drive. Removing a drive may cause data loss in non-fault-tolerant configurations.</p> <p>Either (1) the drive is part of an array being selected by an array configuration utility; (2) Drive Identification has been selected in HP SIM; or (3) drive firmware is being updated.</p>
Off	Off	On	<p>The drive has failed and has been placed offline.</p> <p>You may replace the drive.</p>
Off	Off	Off	<p>Either (1) the drive is not configured as part of an array; (2) the drive is configured as part of an array, but it is a replacement drive that is not being accessed or being rebuilt yet; or (3) the drive is configured as an online spare.</p> <p>If the drive is connected to an array controller, you may replace the drive online.</p>

Hot-plug SATA or SAS IDs

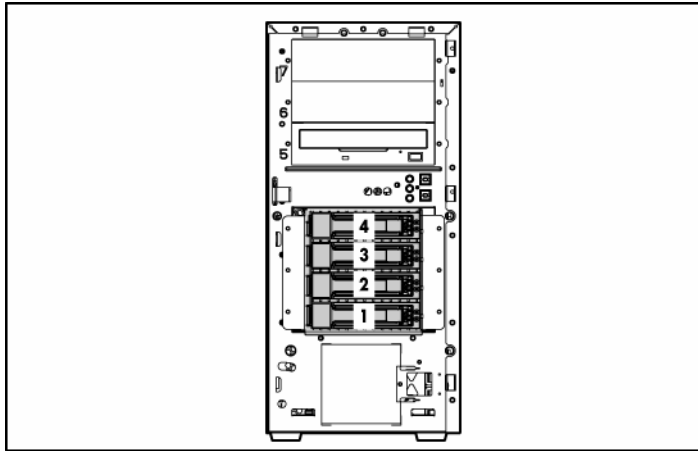

SATA or SAS hard drive LEDs

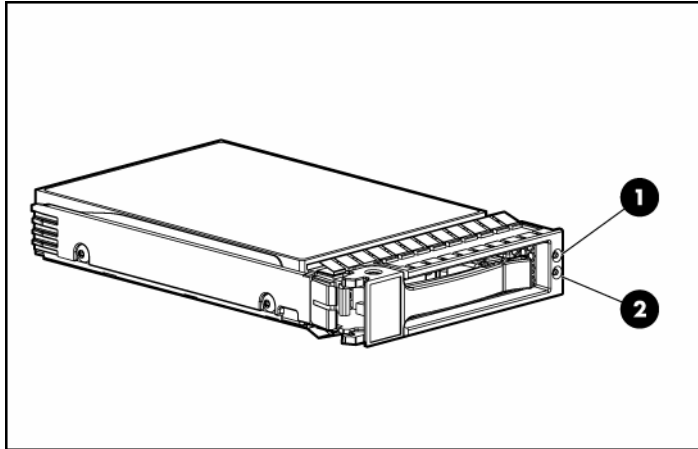

Item	LED description	Status
1	Fault/UID status	Amber = Drive failure Flashing amber = Fault-process activity Blue = Unit identification is active Off = No fault-process activity
2	Online/Activity status	Green = Drive activity Flashing green = High activity on the drive or drive is being configured as part of an array Off = No drive activity

 **IMPORTANT:** When hot-plug SATA hard drives are installed, SATA LED functionality and full SATA hot-plug capability are not supported with the embedded controller. For full LED and hot-plug support, an optional SATA RAID or SAS controller must be installed.

Fan locations

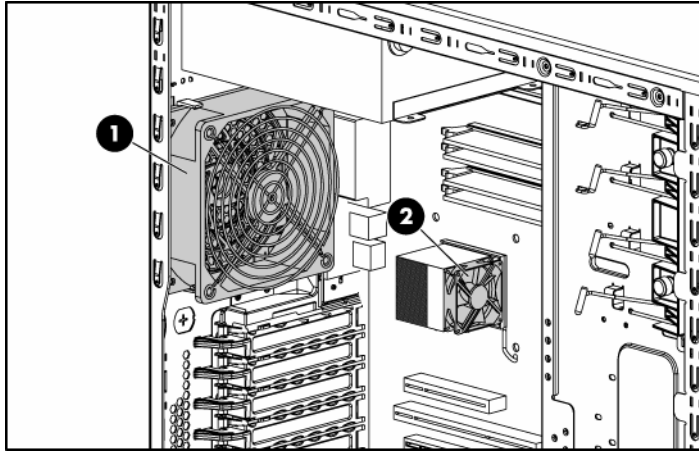

Item	Description
1	System fan
2	Processor fan

Specifications

In this section

Server specifications.....	67
Environmental specifications	68
Hot-plug power supply calculations	68
1.44-MB diskette drive specifications	68
CD-ROM drive specifications	69

Server specifications

Specification	Value
Dimensions	
Height	43 cm (16.93 in)
Depth (w/o bezel)	50 cm (19.69 in)
Depth (w bezel)	54 cm (21.26 in)
Width	20 cm (7.87 in)
Weight (maximum)	22 kg (47.41 lb)
Weight (no drives installed)	16.5 kg (36.24 lb)
Input Requirements	
Rated input voltage	100 VAC to 240 VAC *
Rated input frequency	47 Hz to 63 Hz
Rated input current	10 A (100 V) to 5 A (200 V)
Rated input power	1000 W
BTUs per hour	2730
Power Supply Output	
Rated steady-state power	320 W
Maximum peak power	350 W

*10 A is required for 100 to 127 VAC; 5 A is required for 200 to 240 VAC.

Environmental specifications

Specification	Value
Temperature range*	
Operating	10°C to 35°C (50°F to 95°F)
Shipping	-10°C to 60°C (14°F to 140°F)
Maximum wet bulb temperature	28°C (82.4°F)
Relative humidity (noncondensing)**	
Operating	20% to 80%
Non-operating	20% to 90%

* All temperature ratings shown are for sea level. An altitude derating of 1°C per 300 m (1.8°F per 1,000 ft) to 3048 m (10,000 ft) is applicable. No direct sunlight allowed.

** Storage maximum humidity of 95% is based on a maximum temperature of 45°C (113°F). Altitude maximum for storage corresponds to a pressure minimum of 70 KPa.

Hot-plug power supply calculations

For power supply specifications and calculators to determine electrical and heat loading for the server, refer to the HP Enterprise Configurator website (<http://h30099.www3.hp.com/configurator/>).

1.44-MB diskette drive specifications

Specification	Value
Dimensions	
Height	12.7 mm (0.5 in)
Width	96 mm (3.8 in)

Specification	Value
Depth	130 mm (5.1 in)
LEDs (front panel)	Green = On
Read/write capacity per diskette	
High density	1.44 MB
Low density	720 KB
Drives supported	1
Drive height	One-third height
Drive rotation	300 rpm
Transfer rate	
High	500 Kb/s
Low	250 Kb/s
Bytes/sector	512
Sectors per track (high/low)	18/9
Tracks per side (high/low)	80/80
Access times	
Track-to-track (high/low)	3 ms/6 ms
Average (high/low)	169 ms/94 ms
Setting time	15 ms
Latency average	100 ms
Cylinders (high/low)	80/80
Read/write heads	2

CD-ROM drive specifications

Specification	Value
Disk formats	CD-ROM (modes 1 and 2); mixed mode (audio and data combined); CD-DA; Photo CD (single/multiple-session), CD-XA ready; CDi ready

Specification	Value
Capacity	550 MB (mode 1, 12 cm)
	640 MB (mode 2, 12 cm)
Block size	2368, 2352 bytes (mode 0)
	2352, 2340, 2336, 2048 bytes (mode 1)
	2352, 2340, 2336, 2048 bytes (mode 2)
Dimensions	
Height	12.7 mm (0.50 in)
Depth	132.08 mm (5.20 in)
Width	132.08 mm (5.20 in)
Weight	0.34 kg (0.75 lb)
Data transfer rate	
Sustained	150 KB/s (sustained 1X), 1500/3600 KB/s (10X to 24X)
Burst	16.6 MB/s
Access times (typical)	
Full stroke	300 ms
Random	140 ms
Diameter	12 cm, 8 cm (4.70 in, 3.15 in)
Thickness	1.2 mm (0.05 in)
Track pitch	1.6 μm (6.3×10^{-7} in)
Cache/buffer	128 KB
Startup time	< 10 s
Stop time	< 5 s (single); < 30 s (multisession)
Laser parameters	
Type	Semiconductor laser GaAs
Wave length	700 \pm 25 nm
Divergence angle	53.5° \pm 1.5°
Output power	0.14 mW

Specification	Value
Operating conditions	
Temperature	5°C to 45°C (41°F to 118°F)
Humidity	5% to 90%

Acronyms and abbreviations

ABEND

abnormal end

ACU

Array Configuration Utility

ASR

Automatic Server Recovery

DDR

double data rate

DIMM

dual inline memory module

ECC

error checking and correcting

HBA

host bus adapter

IEC

International Electrotechnical Commission

iLO

Integrated Lights-Out

IML

Integrated Management Log

IPL

initial program load

IRQ

interrupt request

LDAP

Lightweight Directory Access Protocol

MPS

multi-processor specification

NEMA

National Electrical Manufacturers Association

NFPA

National Fire Protection Association

NIC

network interface controller

NMI

non-maskable interrupt

NVRAM

non-volatile memory

PCI-X

peripheral component interconnect extended

PDU

power distribution unit

POST

Power-On Self Test

PPM

Processor Power Module

PSP

ProLiant Support Pack

PXE

preboot eXecution environment

RAID

redundant array of inexpensive (or independent) disks

RBSU

ROM-Based Setup Utility

RILOE II

Remote Insight Lights-Out Edition II

SAS

serial attached SCSI

SATA

serial ATA

SCSI

small computer system interface

SDRAM

synchronous dynamic RAM

SIM

Systems Insight Manager

TMRA

recommended ambient operating temperature

UID

unit identification

VHDCI

very high density cable interconnect

WOL

Wake-on LAN

Index

A

AC power supply 27, 56
access panel 20
ADU (Array Diagnostic Utility) 49
air baffle 25
ASR (Automatic Server Recovery) 73
Automatic Server Recovery (ASR) 73

B

battery 21
bezel, removing 17
buttons 53

C

cabling 45, 46, 47, 48
CD-ROM drive 31, 69
components 53
connectors 53
CSR (customer self repair) 5
customer self repair 5

D

DC power supply 56
diagnostic tools 49, 50
diagnostics utility 50
DIMM slot locations 57
DIMMs 23
diskette drive 30, 68
drive LEDs 62, 63
DVD-ROM drive 31

E

electrostatic discharge 12
expansion boards 21

expansion slots 55

F

fan assembly 25
fan LED 62
fan zones 63
fans 25, 66
fans, replacing 25
front panel components 53
front panel LEDs 54

H

hard drive LEDs 62, 63
hard drive, replacing 17, 18, 37
hard drives 62, 63
hard drives, determining status of 62, 63
hard drives, removing 17, 18, 37
health LEDs 62
HP Insight Diagnostics 50

I

illustrated parts catalog 5
iLO (Integrated Lights-Out) 55
IML (Integrated Management Log) 50
Insight Diagnostics 50

K

keyboard connector 55

L

LEDs 53, 62, 63
LEDs, hard drive 62, 63

M

management tools 49
memory slot LEDs 60
memory slots 57
mouse connector 55

N

network connector LEDs 56
NIC (network interface controller) 74
NIC LEDs 60

O

overtemperature LED 60, 63

P

parallel connector 55
power button/LED board 35
power cord connector 55
power supplies 27, 55, 56
power supply LEDs 56, 60
powering down 15
PPM failure LEDs 60, 63
preparation procedures 15
processor failure LEDs 60
processor fan assembly, removing 27
processor module 27

R

rear panel components 55
rear panel connectors 55
rear panel LEDs 56
RJ-45 connectors 55
RJ-45 network connector LEDs 56

S

safety considerations 12
SAS backplane 40
SAS cabling 48
SAS hard drive cabling 48
SAS-SATA hard drive cage 40
SATA backplane 40
SATA drives 64
SCSI backplane 38
serial connector 55
serial number 55
spare part numbers 6, 7

specifications 67, 68
specifications, environmental 68
specifications, server 67
static electricity 12
Survey Utility 49
switches 57
system board 42, 57, 59
system board battery 21
system board LEDs 59

T

temperature, overtemperature LED 60, 63
tools 49, 55

U

UID LEDs 55, 56
USB connectors 55
utilities 49, 50

V

video connector 55

W

warnings 12, 13