

HP ProLiant ML310 Generation 5 Server Maintenance and Service Guide



Part Number 450223-004
August 2008 (Fourth Edition)

© Copyright 2007, 2008 Hewlett-Packard Development Company, L.P.

The information contained herein is subject to change without notice. The only warranties for HP products and services are set forth in the express warranty statements accompanying such products and services. Nothing herein should be construed as constituting an additional warranty. HP shall not be liable for technical or editorial errors or omissions contained herein.

Microsoft, Windows, and Windows Server are U.S. registered trademarks of Microsoft Corporation.

Intel, Celeron, Core, Pentium, and Xeon are trademarks or registered trademarks of Intel Corporation or its subsidiaries in the United States and other countries.

Intended audience

This guide is for an experienced service technician. HP assumes you are qualified in the servicing of computer equipment and trained in recognizing hazards in products with hazardous energy levels and are familiar with weight and stability precautions for rack installations.

Contents

Customer self repair	5
Parts only warranty service	5
Illustrated parts catalog	16
Mechanical components	16
System components	19
Removal and replacement procedures	24
Required tools	24
Safety considerations	24
Preventing electrostatic discharge	24
Server warnings and cautions	24
Rack warnings	25
Preparation procedures	26
Power down the server	26
Remove the server from the rack	26
Unlock the bezel	27
Bezel	27
Access panel	28
Bezel blank	28
Media bay blank	29
Hard drive blank	30
Hard drives	30
Power button/LED cable	31
Temperature sensor	32
Front USB connectors	33
USB diskette drive	33
Diskette drive	34
SATA optical drive	34
Full-height tape drive	35
USB tape drive	36
Hard drive cage and hard drive backplane	37
Rear fan and fan holder	38
System air baffle and PCI card guide	39
PCI fan	39
Non-redundant power supply	40
Hot-plug power supply	41
Redundant power supply backplane assembly	41
DIMM	42
Heatsink	43
Processor	45
Expansion boards	50
PCI-X extender board	50
Battery	51
System board	52
Server feet	58

Cabling	59
Server cabling	59
SATA hard drive cabling	60
SAS hard drive cabling	60
Diagnostic tools	61
Troubleshooting resources	61
HP Insight Diagnostics	61
HP Insight Diagnostics survey functionality	61
Integrated Management Log	62
ROMPaq disaster recovery	62
Component identification	63
Front panel components	63
Front panel LEDs and buttons	64
SAS and SATA device numbers	65
Hot-plug SATA or SAS hard drive LEDs	65
Rear panel components	66
Rear panel LEDs	67
System board components	68
System maintenance switch	69
NMI functionality	70
System board LEDs	71
System LEDs and internal health LED combinations	72
PCI-X extender board components	73
Fan locations	73
Specifications	74
Environmental specifications	74
Server specifications	74
Acronyms and abbreviations	76
Index	78

Customer self repair

HP products are designed with many Customer Self Repair (CSR) parts to minimize repair time and allow for greater flexibility in performing defective parts replacement. If during the diagnosis period HP (or HP service providers or service partners) identifies that the repair can be accomplished by the use of a CSR part, HP will ship that part directly to you for replacement. There are two categories of CSR parts:

- **Mandatory**—Parts for which customer self repair is mandatory. If you request HP to replace these parts, you will be charged for the travel and labor costs of this service.
- **Optional**—Parts for which customer self repair is optional. These parts are also designed for customer self repair. If, however, you require that HP replace them for you, there may or may not be additional charges, depending on the type of warranty service designated for your product.

NOTE: Some HP parts are not designed for customer self repair. In order to satisfy the customer warranty, HP requires that an authorized service provider replace the part. These parts are identified as "No" in the Illustrated Parts Catalog.

Based on availability and where geography permits, CSR parts will be shipped for next business day delivery. Same day or four-hour delivery may be offered at an additional charge where geography permits. If assistance is required, you can call the HP Technical Support Center and a technician will help you over the telephone. HP specifies in the materials shipped with a replacement CSR part whether a defective part must be returned to HP. In cases where it is required to return the defective part to HP, you must ship the defective part back to HP within a defined period of time, normally five (5) business days. The defective part must be returned with the associated documentation in the provided shipping material. Failure to return the defective part may result in HP billing you for the replacement. With a customer self repair, HP will pay all shipping and part return costs and determine the courier/carrier to be used.

For more information about HP's Customer Self Repair program, contact your local service provider. For the North American program, refer to the HP website (<http://www.hp.com/go/selfrepair>).

Parts only warranty service

Your HP Limited Warranty may include a parts only warranty service. Under the terms of parts only warranty service, HP will provide replacement parts free of charge.

For parts only warranty service, CSR part replacement is mandatory. If you request HP to replace these parts, you will be charged for the travel and labor costs of this service.

Réparation par le client (CSR)

Les produits HP comportent de nombreuses pièces CSR (Customer Self Repair = réparation par le client) afin de minimiser les délais de réparation et faciliter le remplacement des pièces défectueuses. Si pendant la période de diagnostic, HP (ou ses partenaires ou mainteneurs agréés) détermine que la réparation peut être effectuée à l'aide d'une pièce CSR, HP vous l'envoie directement. Il existe deux catégories de pièces CSR:

- **Obligatoire** - Pièces pour lesquelles la réparation par le client est obligatoire. Si vous demandez à HP de remplacer ces pièces, les coûts de déplacement et main d'œuvre du service vous seront facturés.
- **Facultatif** - Pièces pour lesquelles la réparation par le client est facultative. Ces pièces sont également conçues pour permettre au client d'effectuer lui-même la réparation. Toutefois, si vous demandez à HP de remplacer ces pièces, l'intervention peut ou non vous être facturée, selon le type de garantie applicable à votre produit.

REMARQUE: Certaines pièces HP ne sont pas conçues pour permettre au client d'effectuer lui-même la réparation. Pour que la garantie puisse s'appliquer, HP exige que le remplacement de la pièce soit effectué par un Mainteneur Agréé. Ces pièces sont identifiées par la mention "Non" dans le Catalogue illustré.

Les pièces CSR sont livrées le jour ouvré suivant, dans la limite des stocks disponibles et selon votre situation géographique. Si votre situation géographique le permet et que vous demandez une livraison le jour même ou dans les 4 heures, celle-ci vous sera facturée. Pour bénéficier d'une assistance téléphonique, appelez le Centre d'assistance technique HP. Dans les documents envoyés avec la pièce de rechange CSR, HP précise s'il est nécessaire de lui retourner la pièce défectueuse. Si c'est le cas, vous devez le faire dans le délai indiqué, généralement cinq (5) jours ouvrés. La pièce et sa documentation doivent être retournées dans l'emballage fourni. Si vous ne retournez pas la pièce défectueuse, HP se réserve le droit de vous facturer les coûts de remplacement. Dans le cas d'une pièce CSR, HP supporte l'ensemble des frais d'expédition et de retour, et détermine la société de courses ou le transporteur à utiliser.

Pour plus d'informations sur le programme CSR de HP, contactez votre Mainteneur Agréé local. Pour plus d'informations sur ce programme en Amérique du Nord, consultez le site Web HP (<http://www.hp.com/go/selfrepair>).

Service de garantie "pièces seules"

Votre garantie limitée HP peut inclure un service de garantie "pièces seules". Dans ce cas, les pièces de rechange fournies par HP ne sont pas facturées.

Dans le cadre de ce service, la réparation des pièces CSR par le client est obligatoire. Si vous demandez à HP de remplacer ces pièces, les coûts de déplacement et main d'œuvre du service vous seront facturés.

Riparazione da parte del cliente

Per abbreviare i tempi di riparazione e garantire una maggiore flessibilità nella sostituzione di parti difettose, i prodotti HP sono realizzati con numerosi componenti che possono essere riparati direttamente dal cliente (CSR, Customer Self Repair). Se in fase di diagnostica HP (o un centro di servizi o di assistenza HP) identifica il guasto come riparabile mediante un ricambio CSR, HP lo spedisce direttamente al cliente per la sostituzione. Vi sono due categorie di parti CSR:

- **Obbligatorie** – Parti che devono essere necessariamente riparate dal cliente. Se il cliente ne affida la riparazione ad HP, deve sostenere le spese di spedizione e di manodopera per il servizio.
- **Opzionali** – Parti la cui riparazione da parte del cliente è facultativa. Si tratta comunque di componenti progettati per questo scopo. Se tuttavia il cliente ne richiede la sostituzione ad HP, potrebbe dover sostenere spese addizionali a seconda del tipo di garanzia previsto per il prodotto.

NOTA: alcuni componenti HP non sono progettati per la riparazione da parte del cliente. Per rispettare la garanzia, HP richiede che queste parti siano sostituite da un centro di assistenza autorizzato. Tali parti sono identificate da un "No" nel Catalogo illustrato dei componenti.

In base alla disponibilità e alla località geografica, le parti CSR vengono spedite con consegna entro il giorno lavorativo seguente. La consegna nel giorno stesso o entro quattro ore è offerta con un supplemento di costo solo in alcune zone. In caso di necessità si può richiedere l'assistenza telefonica di un addetto del centro di supporto tecnico HP. Nel materiale fornito con una parte di ricambio CSR, HP specifica se il cliente deve restituire dei componenti. Qualora sia richiesta la resa ad HP del componente difettoso, lo si deve spedire ad HP entro un determinato periodo di tempo, generalmente cinque (5) giorni lavorativi. Il componente difettoso deve essere restituito con la documentazione associata nell'imballo di spedizione fornito. La mancata restituzione del componente può comportare la fatturazione del ricambio da parte di HP. Nel caso di riparazione da parte del cliente, HP sostiene tutte le spese di spedizione e resa e sceglie il corriere/vettore da utilizzare.

Per ulteriori informazioni sul programma CSR di HP contattare il centro di assistenza di zona. Per il programma in Nord America fare riferimento al sito Web HP (<http://www.hp.com/go/selfrepair>).

Servizio di garanzia per i soli componenti

La garanzia limitata HP può includere un servizio di garanzia per i soli componenti. Nei termini di garanzia del servizio per i soli componenti, HP fornirà gratuitamente le parti di ricambio.

Per il servizio di garanzia per i soli componenti è obbligatoria la formula CSR che prevede la riparazione da parte del cliente. Se il cliente invece richiede la sostituzione ad HP, dovrà sostenere le spese di spedizione e di manodopera per il servizio.

Customer Self Repair

HP Produkte enthalten viele CSR-Teile (Customer Self Repair), um Reparaturzeiten zu minimieren und höhere Flexibilität beim Austausch defekter Bauteile zu ermöglichen. Wenn HP (oder ein HP Servicepartner) bei der Diagnose feststellt, dass das Produkt mithilfe eines CSR-Teils repariert werden kann, sendet Ihnen HP dieses Bauteil zum Austausch direkt zu. CSR-Teile werden in zwei Kategorien unterteilt:

- **Zwingend** – Teile, für die das Customer Self Repair-Verfahren zwingend vorgegeben ist. Wenn Sie den Austausch dieser Teile von HP vornehmen lassen, werden Ihnen die Anfahrt- und Arbeitskosten für diesen Service berechnet.
- **Optional** – Teile, für die das Customer Self Repair-Verfahren optional ist. Diese Teile sind auch für Customer Self Repair ausgelegt. Wenn Sie jedoch den Austausch dieser Teile von HP vornehmen lassen möchten, können bei diesem Service je nach den für Ihr Produkt vorgesehenen Garantiebedingungen zusätzliche Kosten anfallen.

HINWEIS: Einige Teile sind nicht für Customer Self Repair ausgelegt. Um den Garantieanspruch des Kunden zu erfüllen, muss das Teil von einem HP Servicepartner ersetzt werden. Im illustrierten Teilekatalog sind diese Teile mit „No“ bzw. „Nein“ gekennzeichnet.

CSR-Teile werden abhängig von der Verfügbarkeit und vom Lieferziel am folgenden Geschäftstag geliefert. Für bestimmte Standorte ist eine Lieferung am selben Tag oder innerhalb von vier Stunden gegen einen Aufpreis verfügbar. Wenn Sie Hilfe benötigen, können Sie das HP technische Support Center

anrufen und sich von einem Mitarbeiter per Telefon helfen lassen. Den Materialien, die mit einem CSR-Ersatzteil geliefert werden, können Sie entnehmen, ob das defekte Teil an HP zurückgeschickt werden muss. Wenn es erforderlich ist, das defekte Teil an HP zurückzuschicken, müssen Sie dies innerhalb eines vorgegebenen Zeitraums tun, in der Regel innerhalb von fünf (5) Geschäftstagen. Das defekte Teil muss mit der zugehörigen Dokumentation in der Verpackung zurückgeschickt werden, die im Lieferumfang enthalten ist. Wenn Sie das defekte Teil nicht zurückschicken, kann HP Ihnen das Ersatzteil in Rechnung stellen. Im Falle von Customer Self Repair kommt HP für alle Kosten für die Lieferung und Rücksendung auf und bestimmt den Kurier-/Frachtdienst.

Weitere Informationen über das HP Customer Self Repair Programm erhalten Sie von Ihrem Servicepartner vor Ort. Informationen über das CSR-Programm in Nordamerika finden Sie auf der HP Website unter (<http://www.hp.com/go/selfrepair>).

Parts-only Warranty Service (Garantieservice ausschließlich für Teile)

Ihre HP Garantie umfasst möglicherweise einen Parts-only Warranty Service (Garantieservice ausschließlich für Teile). Gemäß den Bestimmungen des Parts-only Warranty Service stellt HP Ersatzteile kostenlos zur Verfügung.

Für den Parts-only Warranty Service ist das CSR-Verfahren zwingend vorgegeben. Wenn Sie den Austausch dieser Teile von HP vornehmen lassen, werden Ihnen die Anfahrt- und Arbeitskosten für diesen Service berechnet.

Reparaciones del propio cliente

Los productos de HP incluyen muchos componentes que el propio usuario puede reemplazar (*Customer Self Repair*, CSR) para minimizar el tiempo de reparación y ofrecer una mayor flexibilidad a la hora de realizar sustituciones de componentes defectuosos. Si, durante la fase de diagnóstico, HP (o los proveedores o socios de servicio de HP) identifica que una reparación puede llevarse a cabo mediante el uso de un componente CSR, HP le enviará dicho componente directamente para que realice su sustitución. Los componentes CSR se clasifican en dos categorías:

- **Obligatorio:** componentes para los que la reparación por parte del usuario es obligatoria. Si solicita a HP que realice la sustitución de estos componentes, tendrá que hacerse cargo de los gastos de desplazamiento y de mano de obra de dicho servicio.
- **Opcional:** componentes para los que la reparación por parte del usuario es opcional. Estos componentes también están diseñados para que puedan ser reparados por el usuario. Sin embargo, si precisa que HP realice su sustitución, puede o no conllevar costes adicionales, dependiendo del tipo de servicio de garantía correspondiente al producto.

NOTA: Algunos componentes no están diseñados para que puedan ser reparados por el usuario. Para que el usuario haga valer su garantía, HP pone como condición que un proveedor de servicios autorizado realice la sustitución de estos componentes. Dichos componentes se identifican con la palabra "No" en el catálogo ilustrado de componentes.

Según la disponibilidad y la situación geográfica, los componentes CSR se enviarán para que lleguen a su destino al siguiente día laborable. Si la situación geográfica lo permite, se puede solicitar la entrega en el mismo día o en cuatro horas con un coste adicional. Si precisa asistencia técnica, puede llamar al

Centro de asistencia técnica de HP y recibirá ayuda telefónica por parte de un técnico. Con el envío de materiales para la sustitución de componentes CSR, HP especificará si los componentes defectuosos deberán devolverse a HP. En aquellos casos en los que sea necesario devolver algún componente a HP, deberá hacerlo en el periodo de tiempo especificado, normalmente cinco días laborables. Los componentes defectuosos deberán devolverse con toda la documentación relacionada y con el embalaje de envío. Si no enviara el componente defectuoso requerido, HP podrá cobrarle por el de sustitución. En el caso de todas sustituciones que lleve a cabo el cliente, HP se hará cargo de todos los gastos de envío y devolución de componentes y escogerá la empresa de transporte que se utilice para dicho servicio.

Para obtener más información acerca del programa de Reparaciones del propio cliente de HP, póngase en contacto con su proveedor de servicios local. Si está interesado en el programa para Norteamérica, visite la página web de HP siguiente (<http://www.hp.com/go/selfrepair>).

Servicio de garantía exclusivo de componentes

La garantía limitada de HP puede que incluya un servicio de garantía exclusivo de componentes. Según las condiciones de este servicio exclusivo de componentes, HP le facilitará los componentes de repuesto sin cargo adicional alguno.

Para este servicio de garantía exclusivo de componentes, es obligatoria la sustitución de componentes por parte del usuario (CSR). Si solicita a HP que realice la sustitución de estos componentes, tendrá que hacerse cargo de los gastos de desplazamiento y de mano de obra de dicho servicio.

Customer Self Repair

Veel onderdelen in HP producten zijn door de klant zelf te repareren, waardoor de reparatieduur tot een minimum beperkt kan blijven en de flexibiliteit in het vervangen van defecte onderdelen groter is. Deze onderdelen worden CSR-onderdelen (Customer Self Repair) genoemd. Als HP (of een HP Service Partner) bij de diagnose vaststelt dat de reparatie kan worden uitgevoerd met een CSR-onderdeel, verzendt HP dat onderdeel rechtstreeks naar u, zodat u het defecte onderdeel daarmee kunt vervangen. Er zijn twee categorieën CSR-onderdelen:

- **Verplicht:** Onderdelen waarvoor reparatie door de klant verplicht is. Als u HP verzoekt deze onderdelen voor u te vervangen, worden u voor deze service reiskosten en arbeidsloon in rekening gebracht.
- **Optioneel:** Onderdelen waarvoor reparatie door de klant optioneel is. Ook deze onderdelen zijn ontworpen voor reparatie door de klant. Als u echter HP verzoekt deze onderdelen voor u te vervangen, kunnen daarvoor extra kosten in rekening worden gebracht, afhankelijk van het type garanteservice voor het product.

OPMERKING: Sommige HP onderdelen zijn niet ontwikkeld voor reparatie door de klant. In verband met de garantievoorzieningen moet het onderdeel door een geautoriseerde Service Partner worden vervangen. Deze onderdelen worden in de geïllustreerde onderdelencatalogus aangemerkt met "Nee".

Afhankelijk van de leverbaarheid en de locatie worden CSR-onderdelen verzonden voor levering op de eerstvolgende werkdag. Levering op dezelfde dag of binnen vier uur kan tegen meerkosten worden aangeboden, indien dit mogelijk is gezien de locatie. Indien assistentie gewenst is, belt u een HP Service Partner om via de telefoon technische ondersteuning te ontvangen. HP vermeldt in de documentatie bij het vervangende CSR-onderdeel of het defecte onderdeel aan HP moet worden geretourneerd. Als het defecte onderdeel aan HP moet worden teruggezonden, moet u het defecte onderdeel binnen een bepaalde

período, geralmente cinco (5) dias úteis, retornar ao HP. A peça defeituosa deve ser enviada com a documentação correspondente no material de transporte fornecido. Caso contrário, o HP poderá cobrar a reposição. Para as peças de reparo feito pelo cliente, o HP paga todas as despesas de transporte e de devolução da peça e determina a transportadora/serviço postal a ser utilizado.

Para obter mais informações sobre o programa de reparo feito pelo cliente da HP, entre em contato com o fornecedor de serviços local. Para o programa norte-americano, visite o site da HP (<http://www.hp.com/go/selfrepair>).

Garantieservice "Parts Only"

Het is mogelijk dat de HP garantie alleen de garantieservice "Parts Only" omvat. Volgens de bepalingen van de Parts Only garantieservice zal HP kosteloos vervangende onderdelen ter beschikking stellen.

Voor de Parts Only garantieservice is vervanging door CSR-onderdelen verplicht. Als u HP verzoekt deze onderdelen voor u te vervangen, worden u voor deze service reiskosten en arbeidsloon in rekening gebracht.

Reparo feito pelo cliente

Os produtos da HP são projetados com muitas peças para reparo feito pelo cliente (CSR) de modo a minimizar o tempo de reparo e permitir maior flexibilidade na substituição de peças com defeito. Se, durante o período de diagnóstico, a HP (ou fornecedores/parceiros de serviço da HP) concluir que o reparo pode ser efetuado pelo uso de uma peça CSR, a peça de reposição será enviada diretamente ao cliente. Existem duas categorias de peças CSR:

- **Obrigatória** – Peças cujo reparo feito pelo cliente é obrigatório. Se desejar que a HP substitua essas peças, serão cobradas as despesas de transporte e mão-de-obra do serviço.
- **Opcional** – Peças cujo reparo feito pelo cliente é opcional. Essas peças também são projetadas para o reparo feito pelo cliente. No entanto, se desejar que a HP as substitua, pode haver ou não a cobrança de taxa adicional, dependendo do tipo de serviço de garantia destinado ao produto.

OBSERVAÇÃO: Algumas peças da HP não são projetadas para o reparo feito pelo cliente. A fim de cumprir a garantia do cliente, a HP exige que um técnico autorizado substitua a peça. Essas peças estão identificadas com a marca "No" (Não), no catálogo de peças ilustrado.

Conforme a disponibilidade e o local geográfico, as peças CSR serão enviadas no primeiro dia útil após o pedido. Onde as condições geográficas permitirem, a entrega no mesmo dia ou em quatro horas pode ser feita mediante uma taxa adicional. Se precisar de auxílio, entre em contato com o Centro de suporte técnico da HP para que um técnico o ajude por telefone. A HP especifica nos materiais fornecidos com a peça CSR de reposição se a peça com defeito deve ser devolvida à HP. Nos casos em que isso for necessário, é preciso enviar a peça com defeito à HP dentro do período determinado, normalmente cinco (5) dias úteis. A peça com defeito deve ser enviada com a documentação correspondente no material de transporte fornecido. Caso contrário, o HP poderá cobrar a reposição. Para as peças de reparo feito pelo cliente, a HP paga todas as despesas de transporte e de devolução da peça e determina a transportadora/serviço postal a ser utilizado.

Para obter mais informações sobre o programa de reparo feito pelo cliente da HP, entre em contato com o fornecedor de serviços local. Para o programa norte-americano, visite o site da HP (<http://www.hp.com/go/selfrepair>).

Serviço de garantia apenas para peças

A garantia limitada da HP pode incluir um serviço de garantia apenas para peças. Segundo os termos do serviço de garantia apenas para peças, a HP fornece as peças de reposição sem cobrar nenhuma taxa.

No caso desse serviço, a substituição de peças CSR é obrigatória. Se desejar que a HP substitua essas peças, serão cobradas as despesas de transporte e mão-de-obra do serviço.

顧客自己修理保証サービス

修理時間を短縮し、故障部品の交換における高い柔軟性を確保するために、HP製品には多数の顧客自己修理（CSR）部品があります。診断の際に、CSR部品を使用すれば修理ができるとHP（HPまたはHP正規保守代理店）が判断した場合、HPはその部品を直接、お客様に発送し、お客様に交換していただきます。CSR部品には以下の2通りがあります。

- 必須 - 顧客自己修理が必須の部品。当該部品について、もしもお客様がHPに交換作業を依頼される場合には、その修理サービスに関する交通費および人件費がお客様に請求されます。
- 任意 - 顧客自己修理が任意である部品。この部品も顧客自己修理用です。当該部品について、もしもお客様がHPに交換作業を依頼される場合には、お買い上げの製品に適用される保証サービス内容の範囲内においては、別途費用を負担していただくことなく保証サービスを受けることができます。

注： HP製品の一部の部品は、顧客自己修理用ではありません。製品の保証を継続するためには、HPまたはHP正規保守代理店による交換作業が必須となります。部品カタログには、当該部品が顧客自己修理除外品である旨が記載されています。

部品供給が可能な場合、地域によっては、CSR部品を翌営業日に届くように発送します。また、地域によっては、追加費用を負担いただくことにより同日または4時間以内に届くように発送することも可能な場合があります。サポートが必要なときは、HPの修理受付窓口へ電話していただければ、技術者が電話でアドバイスします。交換用のCSR部品または同梱物には、故障部品をHPに返送する必要があるかどうかが表示されています。故障部品をHPに返送する必要がある場合は、指定期限内（通常は5営業日以内）に故障部品をHPに返送してください。故障部品を返送する場合は、届いた時の梱包箱に関連書類とともに入れてください。故障部品を返送しない場合、HPから部品費用が請求されます。顧客自己修理の際には、HPは送料および部品返送費を全額負担し、使用する宅配便会社や運送会社を指定します。

部品のみ保証サービス

HP保証サービスには、部品のみ保証サービスが適用される場合があります。このサービスでは、交換部品は無償で提供されます。

部品のみ保証サービスにおいては、CSR部品をお客様により交換作業していただくことが必須となります。当該部品について、もしもお客様がHPに交換作業を依頼される場合には、その修理サービスに関する交通費および人件費はお客様の負担となります。

客户自行维修

HP 产品提供许多客户自行维修 (CSR) 部件，以尽可能缩短维修时间和在更换缺陷部件方面提供更大的灵活性。如果在诊断期间 HP（或 HP 服务提供商或服务合作伙伴）确定可以通过使用 CSR 部件完成维修，HP 将直接把该部件发送给您进行更换。有两类 CSR 部件：

- **强制性的** — 要求客户必须自行维修的部件。如果您请求 HP 更换这些部件，则必须为该服务支付差旅费和人工费用。
- **可选的** — 客户可以选择是否自行维修的部件。这些部件也是为客户自行维修设计的。不过，如果您要求 HP 为您更换这些部件，则根据为您的产品指定的保修服务类型，HP 可能收取或不再收取任何附加费用。

注：某些 HP 部件的设计并未考虑客户自行维修。为了满足客户保修的需要，HP 要求授权服务提供商更换相关部件。这些部件在部件图解目录中标记为“否”。

CSR 部件将在下一个工作日发运（取决于备货情况和允许的地理范围）。在允许的地理范围内，可在当天或四小时内发运，但要收取额外费用。如果需要帮助，您可以致电 HP 技术支持中心，将会有技术人员通过电话为您提供帮助。HP 会在随更换的 CSR 部件发运的材料中指明是否必须将有缺陷的部件返还给 HP。如果要求您将缺陷的部件返还给 HP，那么您必须在规定期限内（通常是五 (5) 个工作日）将缺陷部件发给 HP。有缺陷的部件必须随所提供的发运材料中的相关文件一起返还。如果未能送还有缺陷的部件，HP 可能会要求您支付更换费用。客户自行维修时，HP 将承担所有相关运输和部件返回费用，并指定快递商/承运商。

有关 HP 客户自行维修计划的详细信息，请与您当地的服务提供商联系。有关北美地区的计划，请访问 HP 网站 (<http://www.hp.com/go/selfrepair>)。

仅部件保修服务

您的 HP 有限保修服务可能涉及仅部件保修服务。根据仅部件保修服务条款的规定，HP 将免费提供更换的部件。

仅部件保修服务要求进行 CSR 部件更换。如果您请求 HP 更换这些部件，则必须为该服务支付差旅费和人工费用。

客戶自行維修

HP 產品設計了許多「客戶自行維修」(CSR) 的零件以減少維修時間，並且使得更換瑕疵零件時能有更大的彈性。如果在診斷期間 HP（或 HP 服務供應商或維修夥伴）辨認出此項維修工作可以藉由使用 CSR 零件來完成，則 HP 將直接寄送該零件給您作更換。CSR 零件分為兩種類別：

- **強制的** — 客戶自行維修所使用的零件是強制性的。如果您要求 HP 更換這些零件，HP 將會向您收取此服務所需的外出費用與勞動成本。
- **選購的** — 客戶自行維修所使用的零件是選購的。這些零件也設計用於客戶自行維修之用。不過，如果您要求 HP 為您更換，則可能需要也可能不需要負擔額外的費用，端視針對此產品指定的保固服務類型而定。

備註：某些 HP 零件沒有消費者可自行維修的設計。為符合客戶保固，HP 需要授權的服務供應商更換零件。這些零件在圖示的零件目錄中，被標示為「否」。

基於材料取得及環境允許的情況下，CSR 零件將於下一個工作日以快遞寄送。在環境的允許下當天或四小時內送達，則可能需要額外的費用。若您需要協助，可致電「HP 技術支援中心」，會有一位技術人員透過電話來協助您。不論損壞的零件是否必須退回，HP 皆會在與 CSR 替換零件一起運送的材料中註明。若要將損壞的零件退回 HP，您必須在指定的一段時間內（通常為五 (5) 個工作天），將損壞的零件寄回 HP。損壞的零件必須與寄送資料中隨附的相關技術文件一併退還。如果無法退還損壞的零件，HP 可能要向您收取替換費用。針對客戶自行維修情形，HP 將負責所有運費及零件退還費用並指定使用何家快遞/貨運公司。

如需 HP 的「客戶自行維修」方案詳細資訊，請連絡您當地的服務供應商。至於北美方案，請參閱 HP 網站 (<http://www.hp.com/go/selfrepair>)。

僅限零件的保固服務

您的「HP 有限保固」可能包含僅限零件的保固服務。在僅限零件的保固服務情況下，HP 將免費提供替換零件。

針對僅限零件的保固服務，CSR 零件替換是強制性的。如果您要求 HP 更換這些零件，HP 將會向您收取此服務所需的外出費用與勞動成本。

고객 셀프 수리

HP 제품은 수리 시간을 최소화하고 결함이 있는 부품 교체 시 더욱 융통성을 발휘할 수 있도록 하기 위해 고객 셀프 수리(CSR) 부품을 다량 사용하여 설계되었습니다. 진단 기간 동안 HP(또는 HP 서비스 공급업체 또는 서비스 협력업체)에서 CSR 부품을 사용하여 수리가 가능하다고 판단되면 HP는 해당 부품을 바로 사용자에게 보내어 사용자가 교체할 수 있도록 합니다. CSR 부품에는 두 가지 종류가 있습니다.

- **고객 셀프 수리가 의무 사항인 필수 부품.** 사용자가 HP에 이 부품의 교체를 요청할 경우 이 서비스에 대한 출장비 및 작업비가 청구됩니다.
- **고객 셀프 수리가 선택 사항인 부품.** 이 부품들도 고객 셀프 수리가 가능하도록 설계되었습니다. 하지만 사용자가 HP에 이 부품의 교체를 요청할 경우 사용자가 구입한 제품에 해당하는 보증 서비스 유형에 따라 추가 비용 없이 교체가 가능할 수 있습니다.

참고: 일부 HP 부품은 고객 셀프 수리가 불가능하도록 설계되었습니다. HP는 만족스러운 고객 보증을 위해 공인 서비스 제공업체를 통해 부품을 교체하도록 하고 있습니다. 이러한 부품들은 Illustrated Parts Catalog에 "No"라고 표시되어 있습니다.

CSR 부품은 재고 상태와 지리적 조건이 허용하는 경우 다음 영업일 납품이 가능하도록 배송이 이루어집니다. 지리적 조건이 허용하는 경우 추가 비용이 청구되는 조건으로 당일 또는 4시간 배송이 가능할 수도 있습니다. 도움이 필요하시면 HP 기술 지원 센터로 전화하십시오. 전문 기술자가 전화로 도움을 줄 것입니다. HP는 결함이 발생한 부품을 HP로 반환해야 하는지 여부를 CSR 교체 부품과 함께 배송된 자료에 지정합니다. 결함이 발생한 부품을 HP로 반환해야 하는 경우에는 지정된 기간 내(통상 영업일 기준 5일)에 HP로 반환해야 합니다. 이 때 결함이 발생한 부품은 제공된 포장 재료에 넣어 관련 설명서와 함께 반환해야 합니다. 결함이 발생한 부품을 반환하지 않는 경우 HP가 교체 부품에 대해 비용을 청구할 수 있습니다. 고객 셀프 수리의 경우, HP는 모든 운송 및 부품 반환 비용을 부담하며 이용할 운송업체 및 택배 서비스를 결정합니다.

HP 고객 셀프 수리 프로그램에 대한 자세한 내용은 가까운 서비스 제공업체에 문의하십시오. 북미 지역의 프로그램에 대해서는 HP 웹 사이트(<http://www.hp.com/go/selfrepair>)를 참조하십시오.

부품 제공 보증 서비스

HP 제한 보증에는 부품 제공 보증 서비스가 포함될 수 있습니다. 이러한 경우 HP는 부품 제공 보증 서비스의 조건에 따라 교체 부품만을 무료로 제공합니다.

부품 제공 보증 서비스 제공 시 CSR 부품 교체는 의무 사항입니다. 사용자가 HP에 이 부품의 교체를 요청할 경우 이 서비스에 대한 출장비 및 작업비가 청구됩니다.

Illustrated parts catalog

Mechanical components

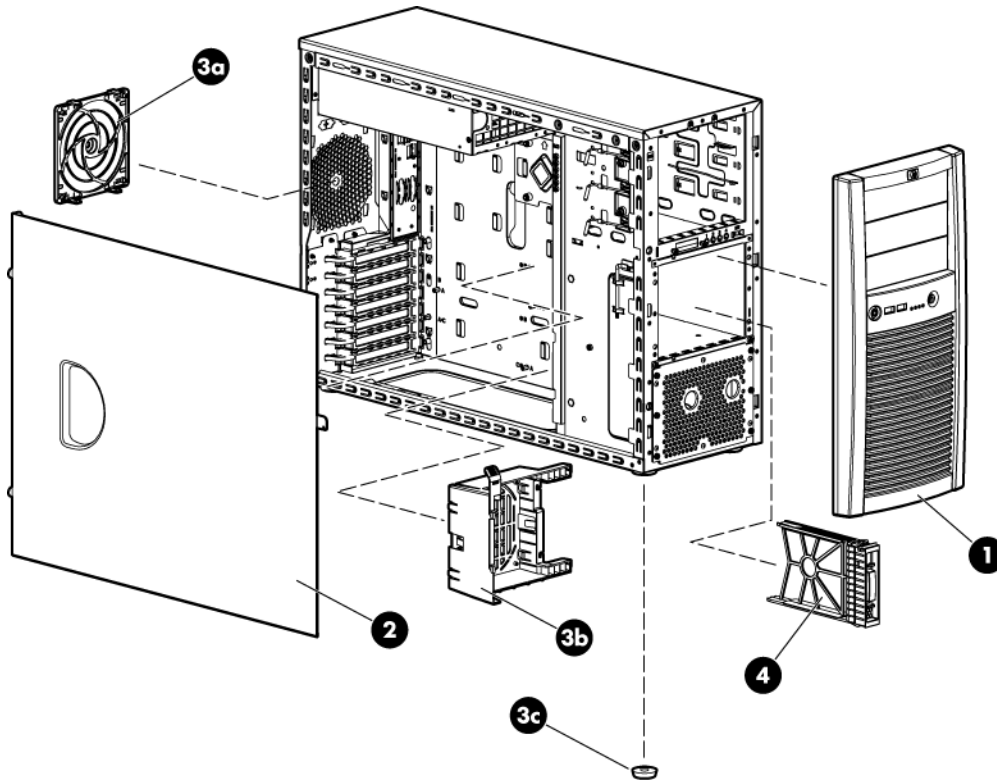

Item	Description	Spare part number	Customer self repair (on page 5)
1	Front bezel	459183-001 Mandatory	¹
2	Access panel	460024-001	Mandatory ¹
3	Plastics kit	460421-001	Mandatory ¹
	a) Fan holder	—	—
	b) System air baffle and PCI card guide	—	—
	c) Server feet	—	—
4	Hard drive blank	459187-001	Mandatory ¹

¹Mandatory—Parts for which customer self repair is mandatory. If you request HP to replace these parts, you will be charged for the travel and labor costs of this service.

²Optional—Parts for which customer self repair is optional. These parts are also designed for customer self repair. If, however, you require that HP replace them for you, there may or may not be additional charges, depending on the type of warranty service designated for your product.

³No—Some HP parts are not designed for customer self repair. In order to satisfy the customer warranty, HP requires that an authorized service provider replace the part. These parts are identified as "No" in the Illustrated Parts Catalog.

¹Mandatory: Obligatoire—Pièces pour lesquelles la réparation par le client est obligatoire. Si vous demandez à HP de remplacer ces pièces, les coûts de déplacement et main d'œuvre du service vous seront facturés.

²Optional: Facultatif—Pièces pour lesquelles la réparation par le client est facultative. Ces pièces sont également conçues pour permettre au client d'effectuer lui-même la réparation. Toutefois, si vous demandez à HP de remplacer ces pièces, l'intervention peut ou non vous être facturée, selon le type de garantie applicable à votre produit.

³No: Non—Certaines pièces HP ne sont pas conçues pour permettre au client d'effectuer lui-même la réparation. Pour que la garantie puisse s'appliquer, HP exige que le remplacement de la pièce soit effectué par un Mainteneur Agréé. Ces pièces sont identifiées par la mention "Non" dans le Catalogue illustré.

¹Mandatory: Obbligatorie—Parti che devono essere necessariamente riparate dal cliente. Se il cliente ne affida la riparazione ad HP, deve sostenere le spese di spedizione e di manodopera per il servizio.

²Optional: Opzionali—Parti la cui riparazione da parte del cliente è facoltativa. Si tratta comunque di componenti progettati per questo scopo. Se tuttavia il cliente ne richiede la sostituzione ad HP, potrebbe dover sostenere spese aggiuntive a seconda del tipo di garanzia previsto per il prodotto.

³No: Non CSR—Alcuni componenti HP non sono progettati per la riparazione da parte del cliente. Per rispettare la garanzia, HP richiede che queste parti siano sostituite da un centro di assistenza autorizzato. Tali parti sono identificate da un "No" nel Catalogo illustrato dei componenti.

¹Mandatory: Zwingend—Teile, die im Rahmen des Customer Self Repair Programms ersetzt werden müssen. Wenn Sie diese Teile von HP ersetzen lassen, werden Ihnen die Versand- und Arbeitskosten für diesen Service berechnet.

²Optional: Optional—Teile, für die das Customer Self Repair-Verfahren optional ist. Diese Teile sind auch für Customer Self Repair ausgelegt. Wenn Sie jedoch den Austausch dieser Teile von HP vornehmen lassen möchten, können bei diesem Service je nach den für Ihr Produkt vorgesehenen Garantiebedingungen zusätzliche Kosten anfallen.

³No: Kein—Einige Teile sind nicht für Customer Self Repair ausgelegt. Um den Garantieanspruch des Kunden zu erfüllen, muss das Teil von einem HP Servicepartner ersetzt werden. Im illustrierten Teilekatalog sind diese Teile mit „No“ bzw. „Nein“ gekennzeichnet.

¹Mandatory: Obligatorio—componentes para los que la reparación por parte del usuario es obligatoria. Si solicita a HP que realice la sustitución de estos componentes, tendrá que hacerse cargo de los gastos de desplazamiento y de mano de obra de dicho servicio.

²Optional: Opcional— componentes para los que la reparación por parte del usuario es opcional. Estos componentes también están diseñados para que puedan ser reparados por el usuario. Sin embargo, si precisa que HP realice su sustitución, puede o no conllevar costes adicionales, dependiendo del tipo de servicio de garantía correspondiente al producto.

³No: No—Algunos componentes no están diseñados para que puedan ser reparados por el usuario. Para que el usuario haga valer su garantía, HP pone como condición que un proveedor de servicios autorizado realice la sustitución de estos componentes. Dichos componentes se identifican con la palabra "No" en el catálogo ilustrado de componentes.

¹Mandatory: Verplicht—Onderdelen waarvoor Customer Self Repair verplicht is. Als u HP verzoekt deze onderdelen te vervangen, komen de reiskosten en het arbeidsloon voor uw rekening.

²Optional: Optioneel—Onderdelen waarvoor reparatie door de klant optioneel is. Ook deze onderdelen zijn ontworpen voor reparatie door de klant. Als u echter HP verzoekt deze onderdelen voor u te vervangen, kunnen daarvoor extra kosten in rekening worden gebracht, afhankelijk van het type garantieservice voor het product.

³No: Nee—Sommige HP onderdelen zijn niet ontwikkeld voor reparatie door de klant. In verband met de garantievooraarden moet het onderdeel door een geautoriseerde Service Partner worden vervangen. Deze onderdelen worden in de geïllustreerde onderdelencatalogus aangemerkt met "Nee".

¹Mandatory: Obrigatória—Peças cujo reparo feito pelo cliente é obrigatório. Se desejar que a HP substitua essas peças, serão cobradas as despesas de transporte e mão-de-obra do serviço.

²Optional: Opcional—Peças cujo reparo feito pelo cliente é opcional. Essas peças também são projetadas para o reparo feito pelo cliente. No entanto, se desejar que a HP as substitua, pode haver ou não a cobrança de taxa adicional, dependendo do tipo de serviço de garantia destinado ao produto.

³No: Nenhuma—Algumas peças da HP não são projetadas para o reparo feito pelo cliente. A fim de cumprir a garantia do cliente, a HP exige que um técnico autorizado substitua a peça. Essas peças estão identificadas com a marca “No” (Não), no catálogo de peças ilustrado.

¹Mandatory: 必須・顧客自己修理が必須の部品。当該部品について、もしもお客様がHPに交換作業を依頼される場合には、その修理サービスに関する交通費および人件費がお客様に請求されます。

²Optional: 任意・顧客自己修理が任意である部品。この部品も顧客自己修理用です。当該部品について、もしもお客様がHPに交換作業を依頼される場合には、お買い上げの製品に適用される保証サービス内容の範囲内においては、費用を負担していただくことなく保証サービスを受けることができます。

³No: 除外・HP製品の一部の部品は、顧客自己修理用ではありません。製品の保証を継続するためには、HPまたはHP正規保守代理店による交換作業が必須となります。部品カタログには、当該部品が顧客自己修理除外品である旨が記載されています。

¹Mandatory: 强制性的 — 要求客户必须自行维修的部件。如果您请求 HP 更换这些部件，则必须为该服务支付差旅费和人工费用。

²Optional: 可选的 — 客户可以选择是否自行维修的部件。这些部件也是为客户自行维修设计的。不过，如果您要求 HP 为您更换这些部件，则根据为您的产品指定的保修服务类型，HP 可能收取或不再收取任何附加费用。

³No: 否 — 某些 HP 部件的设计并未考虑客户自行维修。为了满足客户保修的需要，HP 要求授权服务提供商更换相关部件。这些部件在部件图解目录中标记为“否”。

¹Mandatory: 强制的 — 客户自行维修所使用的零件是强制性的。如果您要求 HP 更换这些零件，HP 将会向您收取此服务所需的外出费用与劳动成本。

²Optional: 選購的 — 客户自行维修所使用的零件是選購的。這些零件也設計用於客戶自行維修之用。不過，如果您要求 HP 為您更換，則可能需要也可能不需要負擔額外的費用，端視針對此產品指定的保固服務類型而定。

³No: 否 — 某些 HP 零件沒有消費者可自行維修的設計。為符合客戶保固，HP 需要授權的服務供應商更換零件。這些零件在圖示的零件目錄中，被標示為「否」。

¹ Mandatory: 필수 — 고객 셀프 수리가 의무 사항인 필수 부품. 사용자가 HP에 이 부품의 교체를 요청할 경우 이 서비스에 대한 출장비 및 작업비가 청구됩니다.

² Optional: 옵션 — 고객 셀프 수리가 선택 사항인 부품. 이 부품들도 고객 셀프 수리가 가능하도록 설계되었습니다. 하지만 사용자가 HP에 이 부품의 교체를 요청할 경우 사용자가 구입한 제품에 해당하는 보증 서비스 유형에 따라 추가 비용 없이 교체가 가능할 수 있습니다.

³ No: No — 고객 셀프 수리가 불가능하도록 설계된 HP 부품. 이 부품들은 고객 셀프 수리가 불가능하도록 설계되었습니다. HP는 고객 보증을 만족시키기 위해 공인 서비스 제공업체를 통해 부품을 교체하도록 하고 있습니다.

System components

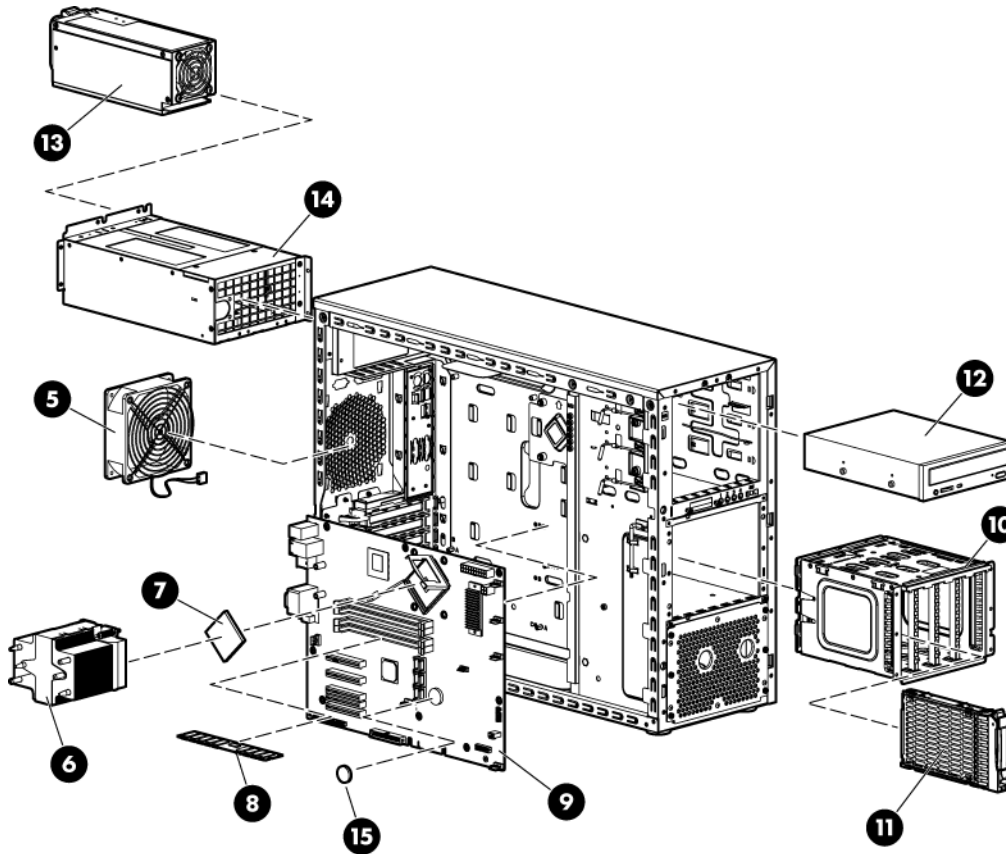

Item	Description	Spare part number	Customer self repair (on page 5)
System components			
5 Fa	n	459188-001	Mandatory ¹
6	Processor heatsink	457021-001	Mandatory ¹
7	Processor	—	—
	a) 1.6-GHz Intel® Celeron® 420, single-core, 512-KB L2 cache, 800-MHz FSB	454523-001 Op	tional ²
	b) 1.8-GHz Intel® Pentium® 2160, dual-core, 1-MB L2 cache, 800-MHz FSB*	455623-001 Op	tional ²
	c) 2.33-GHz Intel® Xeon® 3065, dual-core, 4-MB L2 cache, 1333-MHz FSB*	454525-001 Op	tional ²
	d) 2.66-GHz Intel® Xeon® 3075, dual-core, 4-MB L2 cache, 1333-MHz FSB*	454526-001 Op	tional ²
	e) 3.00-GHz Intel® Xeon® E3110, dual-core, 6-MB L2 cache, 1333-MHz FSB*	463509-001 Op	tional ²
	f) 3.16-GHz Intel® Xeon® E3120, dual-core, 6-MB L2 cache, 1333-MHz FSB*	493930-001 Op	tional ²
	g) 2.13-GHz Intel® Xeon® 3210, quad-core, 8-MB L2 cache, 1066-MHz FSB*	457020-001 Op	tional ²

Item	Description	Spare part number	Customer self repair (on page 5)
	h) 2.40-GHz Intel® Xeon® 3220, quad-core, 8-MB L2 cache, 1066-MHz FSB*	454529-001 Op	tional ²
	i) 2.00-GHz Intel® Core™2 E4400, dual-core, 2-MB L2 cache, 800-MHz FSB*	454528-001 Op	tional ²
	j) 2.40-GHz Intel® Core™2 E4600, dual-core, 2-MB L2 cache, 800-MHz FSB*	462569-001 Op	tional ²
	k) 2.66-GHz Intel® Xeon® X3350, quad-core, 12-MB L2 cache, 1333-MHz FSB*	463507-001 Op	tional ²
	l) 2.50-GHz Intel® Xeon® X3320, quad-core, 6-MB L2 cache, 1333-MHz FSB*	463508-001 Op	tional ²
	m) 2.66-GHz Intel® Xeon® X3330, quad-core, 6-MB L2 cache, 1333-MHz FSB*	493929-001 Op	tional ²
	n) 2.83-GHz Intel® Xeon® X3360, quad-core, 12-MB L2 cache, 1333-MHz FSB*	469859-001 Op	tional ²
	o) 3.00-GHz Intel® Xeon® X3370, quad-core, 12-MB L2 cache, 1333-MHz FSB*	493928-001 Op	tional ²
	p) 2.00-GHz Intel® Celeron® C440, single-core, 512-KB L2 cache, 800-MHz FSB*	454524-001 Op	tional ²
	Memory		
8	PC2-6400 ECC RoHS DIMM	—	—
	a) 512-MB	459931-001	Mandatory ¹
	b) 1-GB*	459932-001	Mandatory ¹
	c) 2-GB*	460424-001	Mandatory ¹
	Boards		
9 System	board	454510-001	Optional ²
10	Hard drive cage with hard drive backplane	459191-001	Optional ²
	Mass storage devices		
11 Hard	drive	—	—
	a) 36-GB, SAS, 10,000-rpm	376593-001	Mandatory ¹
	b) 72-GB, SAS, 10,000-rpm*	376594-001	Mandatory ¹
	c) 146-GB, SAS, 10,000-rpm*	376595-001	Mandatory ¹
	d) 72-GB, SAS, dual-port, 15,000-rpm*	389343-001	Mandatory ¹
	e) 146-GB, SAS, dual-port, 15,000-rpm*	389344-001	Mandatory ¹
	f) 300-GB, SAS, dual-port, 15,000-rpm*	416428-001	Mandatory ¹
	g) 80-GB, SATA, 7,200-rpm*	397551-001	Mandatory ¹
	h) 160-GB, SATA, 7,200-rpm*	397552-001	Mandatory ¹
	i) 250-GB, SATA, 7,200-rpm*	397553-001	Mandatory ¹
	j) 500-GB, SATA, 7,200-rpm*	395501-001	Mandatory ¹
	k) 750-GB, SATA, 7,200-rpm*	432401-001	Mandatory ¹

Item	Description	Spare part number	Customer self repair (on page 5)
12 DV	D-ROM drive	447464-001	Mandatory ¹
	Power		
13 Power	supplies	—	—
	a) Hot-plug power supply, 430-W	432479-001	Mandatory ¹
	b) Non-hot-plug power supply, 410-W*	460422-001	Mandatory ¹
14	Power supply cage with backplane	432478-001	Mandatory ¹
15 System	battery	234556-001	Mandatory ¹
	Cables		
16	Optical drive cable*	459189-001	Mandatory ¹
17	SAS/SATA hard drive cable*	459190-001	Mandatory ¹
18	SAS hard drive cable*	459934-001	Mandatory ¹
19	Power button/LED cable*	459186-001	Mandatory ¹
20	Temperature sensor cable*	460423-001	Mandatory ¹
21	Front USB cable*	459184-001	Mandatory ¹
	Miscellaneous		
22	T-10/T-15 Torx screwdriver*	413965-001	Mandatory ¹
23 Bezel	key*	405168-001	Mandatory ¹
	Options		
24 DV	D-RW drive*	447466-001	Mandatory ¹
25 Disk	ette drive*	392545-001	Mandatory ¹
26 PC	I-X extender board*	462412-001	Mandatory ¹
27	HP Smart Array E200 Controller*	412799-001	Mandatory ¹
28	HP Smart Array E500 Controller*	444843-001	Mandatory ¹
29	HP Smart Array P400 Controller*	405832-001	Mandatory ¹
30	HP Smart Array P800 Controller*	398647-001	Mandatory ¹

* Not shown

¹Mandatory—Parts for which customer self repair is mandatory. If you request HP to replace these parts, you will be charged for the travel and labor costs of this service.

²Optional—Parts for which customer self repair is optional. These parts are also designed for customer self repair. If, however, you require that HP replace them for you, there may or may not be additional charges, depending on the type of warranty service designated for your product.

³No—Some HP parts are not designed for customer self repair. In order to satisfy the customer warranty, HP requires that an authorized service provider replace the part. These parts are identified as "No" in the Illustrated Parts Catalog.

¹Mandatory: Obligatoire—Pièces pour lesquelles la réparation par le client est obligatoire. Si vous demandez à HP de remplacer ces pièces, les coûts de déplacement et main d'œuvre du service vous seront facturés.

²Optional: Facultatif—Pièces pour lesquelles la réparation par le client est facultative. Ces pièces sont également conçues pour permettre au client d'effectuer lui-même la réparation. Toutefois, si vous demandez à HP de remplacer ces pièces, l'intervention peut ou non vous être facturée, selon le type de garantie applicable à votre produit.

³No: Non—Certaines pièces HP ne sont pas conçues pour permettre au client d'effectuer lui-même la réparation. Pour que la garantie puisse s'appliquer, HP exige que le remplacement de la pièce soit effectué par un Mainteneur Agréé. Ces pièces sont identifiées par la mention "Non" dans le Catalogue illustré.

¹Mandatory: Obbligatorie—Parti che devono essere necessariamente riparate dal cliente. Se il cliente ne affida la riparazione ad HP, deve sostenere le spese di spedizione e di manodopera per il servizio.

²Optional: Opzionali—Parti la cui riparazione da parte del cliente è facoltativa. Si tratta comunque di componenti progettati per questo scopo. Se tuttavia il cliente ne richiede la sostituzione ad HP, potrebbe dover sostenere spese addizionali a seconda del tipo di garanzia previsto per il prodotto.

³No: Non CSR—Alcuni componenti HP non sono progettati per la riparazione da parte del cliente. Per rispettare la garanzia, HP richiede che queste parti siano sostituite da un centro di assistenza autorizzato. Tali parti sono identificate da un "No" nel Catalogo illustrato dei componenti.

¹Mandatory: Zwingend—Teile, die im Rahmen des Customer Self Repair Programms ersetzt werden müssen. Wenn Sie diese Teile von HP ersetzen lassen, werden Ihnen die Versand- und Arbeitskosten für diesen Service berechnet.

²Optional: Optional—Teile, für die das Customer Self Repair-Verfahren optional ist. Diese Teile sind auch für Customer Self Repair ausgelegt. Wenn Sie jedoch den Austausch dieser Teile von HP vornehmen lassen möchten, können bei diesem Service je nach den für Ihr Produkt vorgesehenen Garantiebedingungen zusätzliche Kosten anfallen.

³No: Kein—Einige Teile sind nicht für Customer Self Repair ausgelegt. Um den Garantieanspruch des Kunden zu erfüllen, muss das Teil von einem HP Servicepartner ersetzt werden. Im illustrierten Teilekatalog sind diese Teile mit „No“ bzw. „Nein“ gekennzeichnet.

¹Mandatory: Obligatorio—componentes para los que la reparación por parte del usuario es obligatoria. Si solicita a HP que realice la sustitución de estos componentes, tendrá que hacerse cargo de los gastos de desplazamiento y de mano de obra de dicho servicio.

²Optional: Opcional— componentes para los que la reparación por parte del usuario es opcional. Estos componentes también están diseñados para que puedan ser reparados por el usuario. Sin embargo, si precisa que HP realice su sustitución, puede o no conllevar costes adicionales, dependiendo del tipo de servicio de garantía correspondiente al producto.

³No: No—Algunos componentes no están diseñados para que puedan ser reparados por el usuario. Para que el usuario haga valer su garantía, HP pone como condición que un proveedor de servicios autorizado realice la sustitución de estos componentes. Dichos componentes se identifican con la palabra "No" en el catálogo ilustrado de componentes.

¹Mandatory: Verplicht—Onderdelen waarvoor Customer Self Repair verplicht is. Als u HP verzoekt deze onderdelen te vervangen, komen de reiskosten en het arbeidsloon voor uw rekening.

²Optional: Optioneel—Onderdelen waarvoor reparatie door de klant optioneel is. Ook deze onderdelen zijn ontworpen voor reparatie door de klant. Als u echter HP verzoekt deze onderdelen voor u te vervangen, kunnen daarvoor extra kosten in rekening worden gebracht, afhankelijk van het type garantieservice voor het product.

³No: Nee—Sommige HP onderdelen zijn niet ontwikkeld voor reparatie door de klant. In verband met de garantievooraarden moet het onderdeel door een geautoriseerde Service Partner worden vervangen. Deze onderdelen worden in de geïllustreerde onderdelencatalogus aangemerkt met "Nee".

¹Mandatory: Obrigatória—Peças cujo reparo feito pelo cliente é obrigatório. Se desejar que a HP substitua essas peças, serão cobradas as despesas de transporte e mão-de-obra do serviço.

²Optional: Opcional—Peças cujo reparo feito pelo cliente é opcional. Essas peças também são projetadas para o reparo feito pelo cliente. No entanto, se desejar que a HP as substitua, pode haver ou não a cobrança de taxa adicional, dependendo do tipo de serviço de garantia destinado ao produto.

³No: Nenhuma—Algumas peças da HP não são projetadas para o reparo feito pelo cliente. A fim de cumprir a garantia do cliente, a HP exige que um técnico autorizado substitua a peça. Essas peças estão identificadas com a marca "No" (Não), no catálogo de peças ilustrado.

¹Mandatory: 必須・顧客自己修理が必須の部品。当該部品について、もしもお客様がHPに交換作業を依頼される場合には、その修理サービスに関する交通費および人件費がお客様に請求されます。

²Optional: 任意・顧客自己修理が任意である部品。この部品も顧客自己修理用です。当該部品について、もしもお客様がHPに交換作業を依頼される場合には、お買い上げの製品に適用される保証サービス内容の範囲内においては、費用を負担していただくことなく保証サービスを受けることができます。

³No: 除外・HP製品の一部の部品は、顧客自己修理用ではありません。製品の保証を継続するためには、HPまたはHP正規保守代理店による交換作業が必須となります。部品カタログには、当該部品が顧客自己修理除外品である旨が記載されています。

¹Mandatory: 强制性的 — 要求客户必须自行维修的部件。如果您请求 HP 更换这些部件，则必须为该服务支付差旅费和人工费用。

²Optional: 可选的 — 客户可以选择是否自行维修的部件。这些部件也是为客户自行维修设计的。不过，如果您要求 HP 为您更换这些部件，则根据为您的产品指定的保修服务类型，HP 可能收取或不再收取任何附加费用。

³No: 否 — 某些 HP 部件的设计并未考虑客户自行维修。为了满足客户保修的需要，HP 要求授权服务提供商更换相关部件。这些部件在部件图解目录中标记为“否”。

¹Mandatory: 强制的 — 客户自行维修所使用的零件是强制性的。如果您要求 HP 更换这些零件，HP 将会向您收取此服务所需的外出费用与劳动成本。

²Optional: 選購的 — 客户自行维修所使用的零件是選購的。這些零件也設計用於客戶自行維修之用。不過，如果您要求 HP 為您更換，則可能需要也可能不需要負擔額外的費用，端視針對此產品指定的保固服務類型而定。

³No: 否 — 某些 HP 零件沒有消費者可自行維修的設計。為符合客戶保固，HP 需要授權的服務供應商更換零件。這些零件在圖示的零件目錄中，被標示為「否」。

¹ Mandatory: 필수 — 고객 셀프 수리가 의무 사항인 필수 부품. 사용자가 HP에 이 부품의 교체를 요청할 경우 이 서비스에 대한 출장비 및 작업비가 청구됩니다.

² Optional: 옵션 — 고객 셀프 수리가 선택 사항인 부품. 이 부품들도 고객 셀프 수리가 가능하도록 설계되었습니다. 하지만 사용자가 HP에 이 부품의 교체를 요청할 경우 사용자가 구입한 제품에 해당하는 보증 서비스 유형에 따라 추가 비용 없이 교체가 가능할 수 있습니다.

³ No: No — 고객 셀프 수리가 불가능하도록 설계된 HP 부품. 이 부품들은 고객 셀프 수리가 불가능하도록 설계되었습니다. HP는 고객 보증을 만족시키기 위해 공인 서비스 제공업체를 통해 부품을 교체하도록 하고 있습니다.

Removal and replacement procedures

Required tools

You need the following items for some procedures:

- T-10/T-15 Torx screwdriver (included with the server)
- HP Insight Diagnostics software ("[HP Insight Diagnostics](#)" on page 61)

Safety considerations

Before performing service procedures, review all the safety information.

Preventing electrostatic discharge

To prevent damaging the system, be aware of the precautions you need to follow when setting up the system or handling parts. A discharge of static electricity from a finger or other conductor may damage system boards or other static-sensitive devices. This type of damage may reduce the life expectancy of the device.

To prevent electrostatic damage:

- Avoid hand contact by transporting and storing products in static-safe containers.
- Keep electrostatic-sensitive parts in their containers until they arrive at static-free workstations.
- Place parts on a grounded surface before removing them from their containers.
- Avoid touching pins, leads, or circuitry.
- Always be properly grounded when touching a static-sensitive component or assembly.





Server warnings and cautions

Before installing a server, be sure that you understand the following warnings and cautions.





WARNING: To reduce the risk of electric shock or damage to the equipment:

- Do not disable the power cord grounding plug. The grounding plug is an important safety feature.
 - Plug the power cord into a grounded (earthed) electrical outlet that is easily accessible at all times.
 - Unplug the power cord from the power supply to disconnect power to the equipment.
 - Do not route the power cord where it can be walked on or pinched by items placed against it. Pay particular attention to the plug, electrical outlet, and the point where the cord extends from the server.
-

-
-  **WARNING:** To reduce the risk of personal injury from hot surfaces, allow the drives and the internal system components to cool before touching them.
-
-  **WARNING:** To reduce the risk of personal injury, electric shock, or damage to the equipment, remove the power cord to remove power from the server. The front panel Power On/Standby button does not completely shut off system power. Portions of the power supply and some internal circuitry remain active until AC power is removed.
-
-  **CAUTION:** Do not operate the server for long periods with the access panel open or removed. Operating the server in this manner results in improper airflow and improper cooling that can lead to thermal damage.
-
-  **CAUTION:** Protect the server from power fluctuations and temporary interruptions with a regulating uninterruptible power supply (UPS). This device protects the hardware from damage caused by power surges and voltage spikes and keeps the system in operation during a power failure.
-

Rack warnings

-
-  **WARNING:** To reduce the risk of personal injury or damage to the equipment, be sure that:
- The leveling jacks are extended to the floor.
 - The full weight of the rack rests on the leveling jacks.
 - The stabilizing feet are attached to the rack if it is a single-rack installation.
 - The racks are coupled together in multiple-rack installations.
 - Only one component is extended at a time. A rack may become unstable if more than one component is extended for any reason.
-
-  **WARNING:** To reduce the risk of personal injury or equipment damage when unloading a rack:
- At least two people are needed to safely unload the rack from the pallet. An empty 42U rack can weigh as much as 115 kg (253 lb), can stand more than 2.1 m (7 ft) tall, and may become unstable when being moved on its casters.
 - Never stand in front of the rack when it is rolling down the ramp from the pallet. Always handle the rack from both sides.
-
-  **WARNING:** When installing a server in a telco rack, be sure that the rack frame is adequately secured to the top and bottom of the building structure.
-



WARNING: This server is very heavy. To reduce the risk of personal injury or damage to the equipment:

- Observe local occupational health and safety requirements and guidelines for manual material handling.
 - Get help to lift and stabilize the product during installation or removal, especially when the product is not fastened to the rails. When the server weighs more than 22.5 kg (50 lb), at least two people must lift the server into the rack together. A third person may be required to help align the server if the server is installed higher than chest level.
 - Use caution when installing the server in or removing the server from the rack; it is unstable when not fastened to the rails.
-

Preparation procedures

Power down the server



WARNING: To reduce the risk of personal injury, electric shock, or damage to the equipment, remove the power cord to remove power from the server. The front panel Power On/Standby button does not completely shut off system power. Portions of the power supply and some internal circuitry remain active until AC power is removed.



IMPORTANT: If installing a hot-plug device, it is not necessary to power down the server.

1. Shut down the OS as directed by the OS documentation.
2. Press the Power On/Standby button to place the server in standby mode. When the server enters standby power mode, the system power LED changes to amber.
3. Disconnect the power cords.

The system is now without power.

Remove the server from the rack

If the server is installed with an optional rack enabling kit, remove the server from the rack before beginning any service procedures.

1. Power down the server (on page 26).
2. Disconnect peripheral device and power cables.
3. Release the server/tray from the rack.
4. Extend the server/tray from the rack.
5. Remove the server from the tray and place it on a flat work surface.

Unlock the bezel

Unlock and remove the bezel before accessing the hard drive cage and media bays. Unlock the bezel before removing the access panel. Close and lock the bezel during normal server operations to ensure proper cooling airflow.

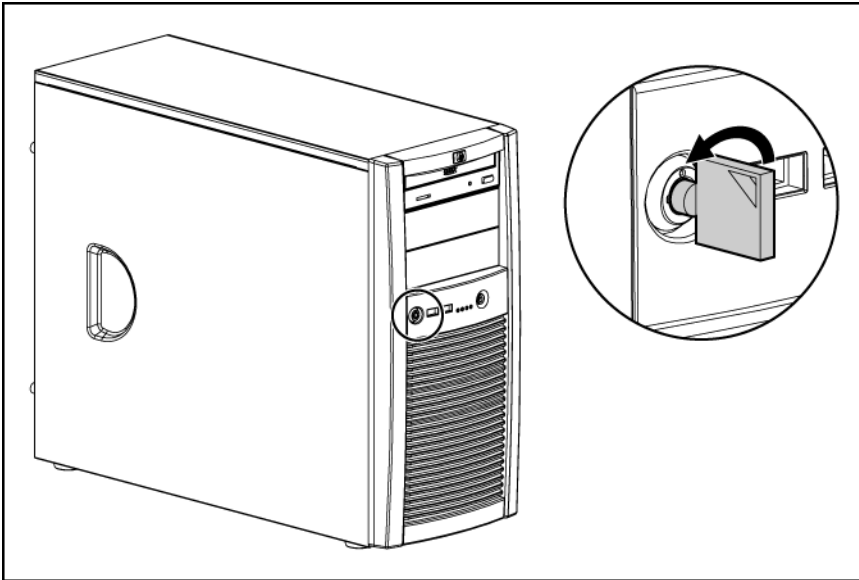

Bezel

Unlock and remove the bezel before accessing the hard drive cage and media bays. Unlock the bezel before removing the access panel. Close and lock the bezel during normal server operations to ensure proper cooling airflow.

To remove the component:

1. Power down the server (on page [26](#)).
2. Unlock the bezel.

3. Remove the bezel.

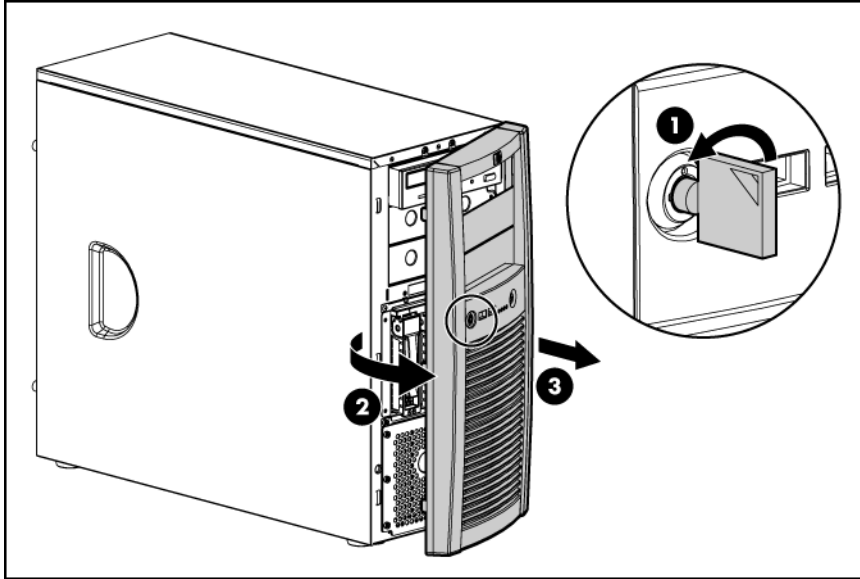

To replace the component, reverse the removal procedure.

Access panel



WARNING: To reduce the risk of personal injury from hot surfaces, allow the drives and the internal system components to cool before touching them.



CAUTION: Do not operate the server for long periods with the access panel open or removed. Operating the server in this manner results in improper airflow and improper cooling that can lead to thermal damage.

To remove the component:

1. Power down the server (on page 26).
2. Remove the server from the rack, if necessary ("[Remove the server from the rack](#)" on page 26).
3. Unlock and open the bezel ("[Unlock the bezel](#)" on page 27).
4. Loosen the two thumbscrews.
5. Slide the access panel toward the rear of the server and remove from the server.

To replace the component, reverse the removal procedure.

Bezel blank

To remove the component:

1. Power down the server (on page 26).
2. Remove the front bezel ("[Bezel](#)" on page 27).

3. Remove a bezel blank.

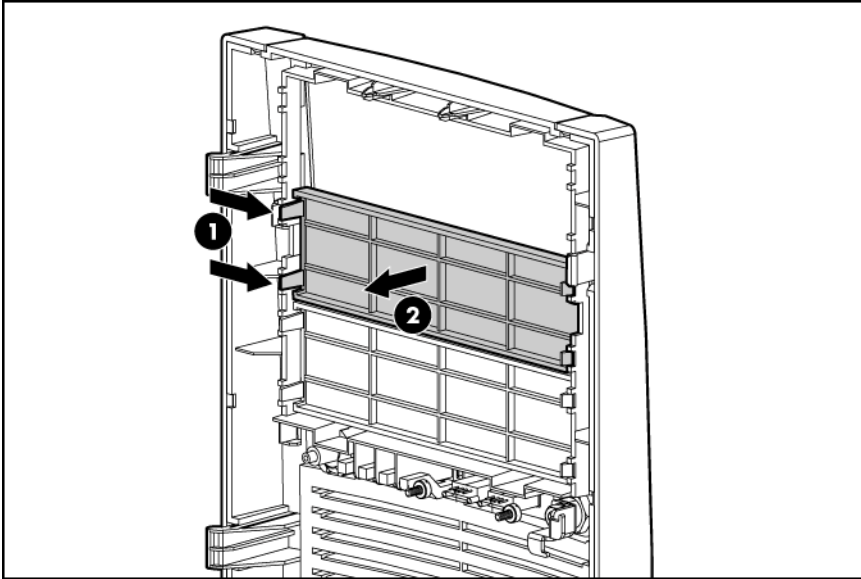

To replace the component, reverse the removal procedure.

Media bay blank

To remove the component:

1. Power down the server (on page 26).
2. Remove the front bezel ("Bezel" on page 27).
3. Remove a media bay blank.

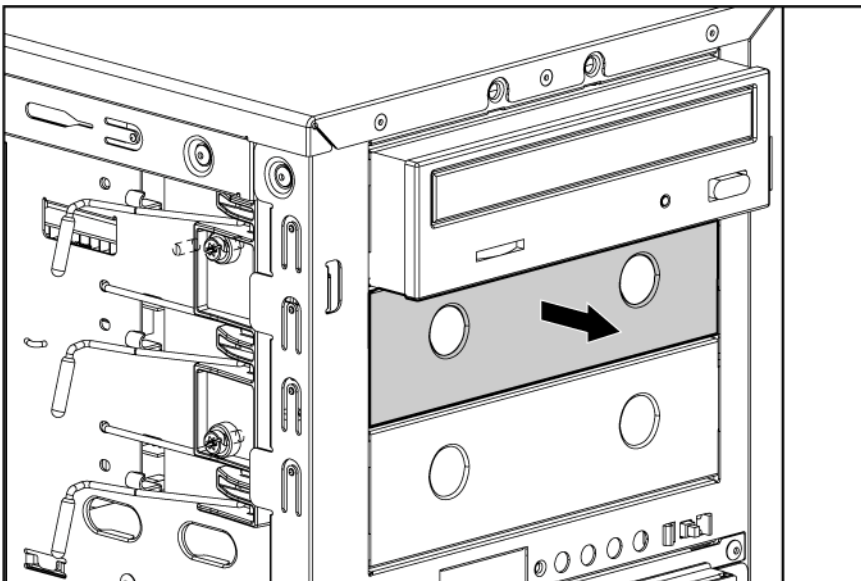

To replace the component, reverse the removal procedure.

Hard drive blank

Remove the component as indicated.

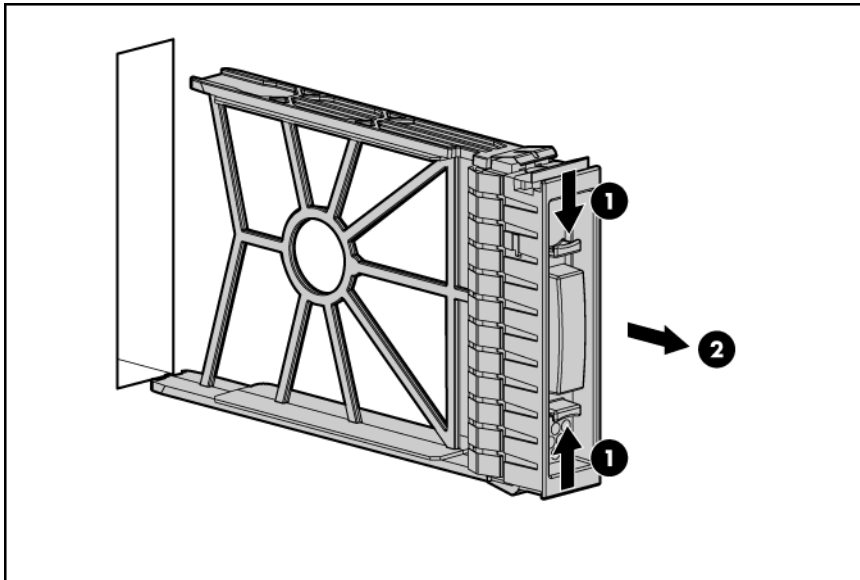

To replace the component, slide the component into the bay until it clicks.

Hard drives

To remove the component:



CAUTION: To prevent improper cooling and thermal damage, do not operate the server unless all bays are populated with either a component or a blank.

1. Determine the status of the hard drive from the hot-plug hard drive LEDs ("[Hot-plug SATA or SAS hard drive LEDs](#)" on page 65).



IMPORTANT: When hot-plug SATA hard drives are installed, SATA LED functionality and full SATA hot-plug capability are not supported with the embedded controller. For full LED and hot-plug support, an optional SATA RAID or SAS controller must be installed.

2. Unlock and open the bezel ("[Unlock the bezel](#)" on page 27).

3. Remove the hard drive.

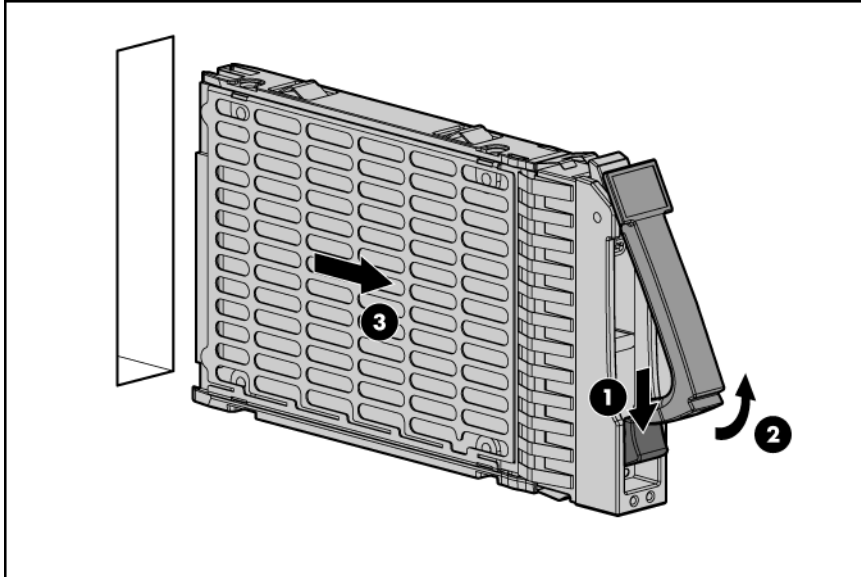

To replace the component:

1. Slide the drive into the cage until it clicks, locking the drive into place.
2. Close the lever.



IMPORTANT: When the drive is inserted, the drive LEDs flash for 2 seconds to indicate that the drive is seated properly and receiving power.

3. As the drive begins to spin, be sure that the drive LEDs illuminate one at a time and then turn off together to indicate that the system has recognized the new drive.
4. In fault-tolerant configurations, allow the replacement drive to be reconstructed automatically with data from the other drives. While reconstruction is in progress, the online LED flashes.

Power button/LED cable

To remove the component:

1. Power down the server (on page 26).
2. Remove the bezel ("Bezel" on page 27).
3. Remove the access panel ("Access panel" on page 28).
4. Remove the media drive in the bottom bay, if necessary ("SATA optical drive" on page 34).
5. Disconnect the power button/LED cable from the system board ("System board components" on page 68).

6. Remove the power button/LED cable.

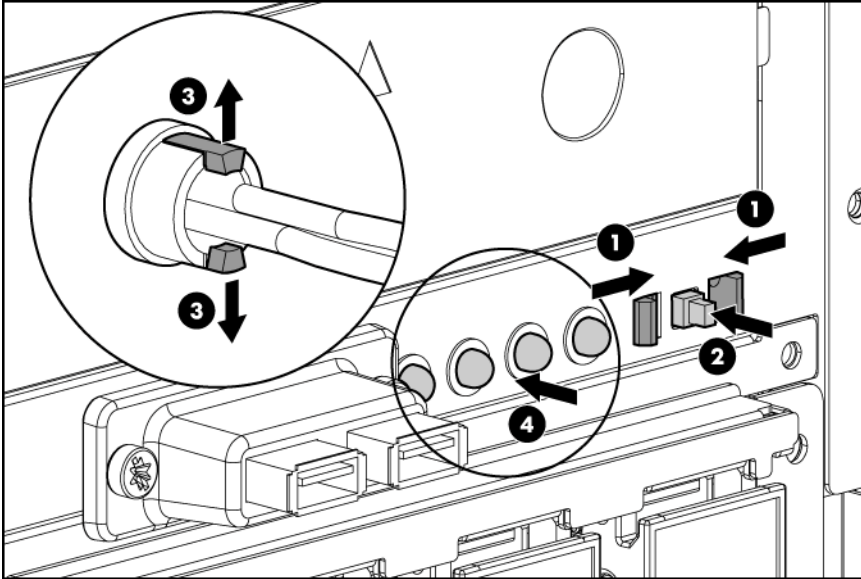

To replace the component, reverse the removal procedure.

Temperature sensor

To remove the component:

1. Power down the server (on page 26).
2. Remove the bezel ("Bezel" on page 27).
3. Remove the access panel ("Access panel" on page 28).
4. Disconnect the temperature sensor cable from the system board ("System board components" on page 68).
5. Remove the temperature sensor.

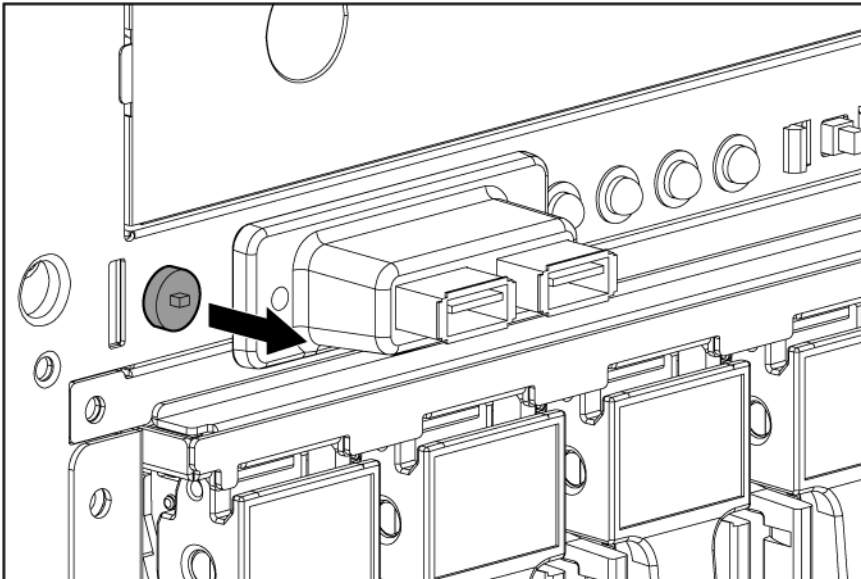

To replace the component, reverse the removal procedure.

Front USB connectors

To remove the component:

1. Power down the server (on page 26).
2. Remove the bezel ("Bezel" on page 27).
3. Remove the access panel ("Access panel" on page 28).
4. Disconnect the front USB cable from the system board ("System board components" on page 68).
5. Remove the front USB connectors.

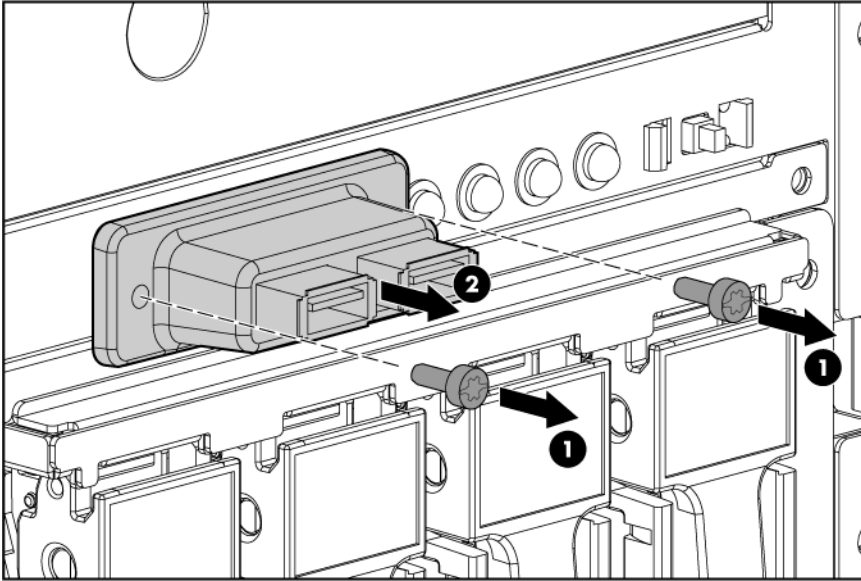

To replace the component, reverse the removal procedure.

USB diskette drive

Disconnect a USB diskette drive from the USB connector on the server front panel.

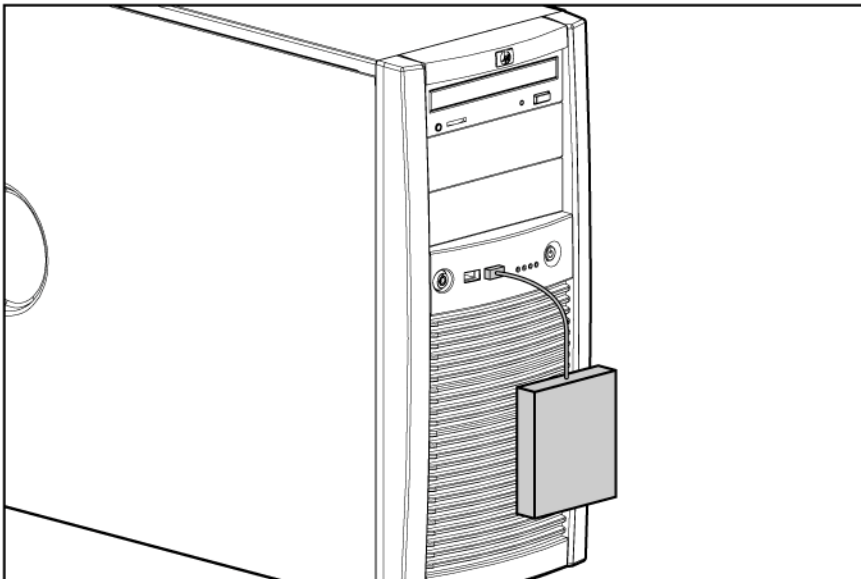

Diskette drive

CAUTION: To prevent improper cooling and thermal damage, do not operate the server unless all bays are populated with either a component or a blank.

To remove the component:

1. Power down the server (on page 26).
2. Remove the bezel ("Bezel" on page 27).
3. Remove the access panel ("Access panel" on page 28).
4. Disconnect the power and data cables from the drive and the system board ("System board components" on page 68).
5. Remove the diskette drive.

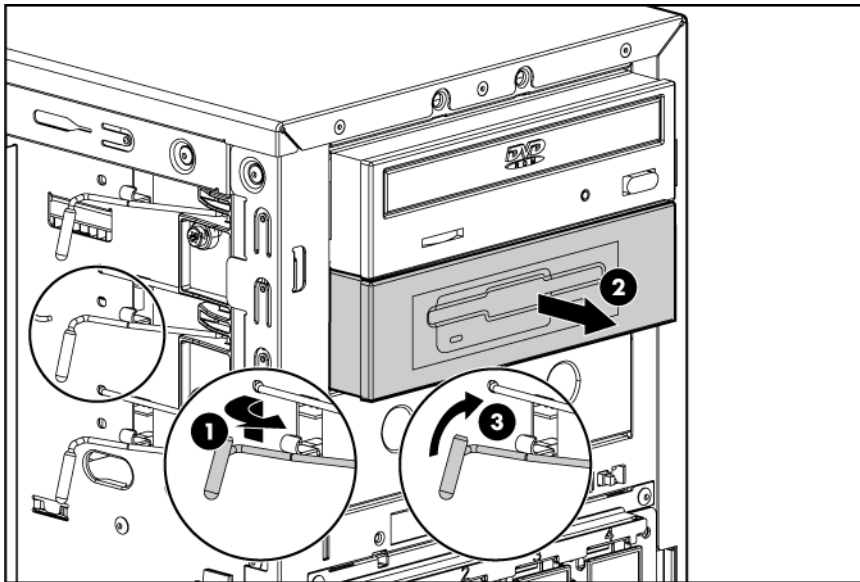

To replace the component, reverse the removal procedure.

SATA optical drive

CAUTION: To prevent improper cooling and thermal damage, do not operate the server unless all bays are populated with either a component or a blank.

To remove the component:

1. Power down the server (on page 26).
2. Remove the bezel ("Bezel" on page 27).
3. Remove the access panel ("Access panel" on page 28).
4. Disconnect the power and data cables from the rear of the drive and the system board ("System board components" on page 68).

5. Remove the SATA optical drive.

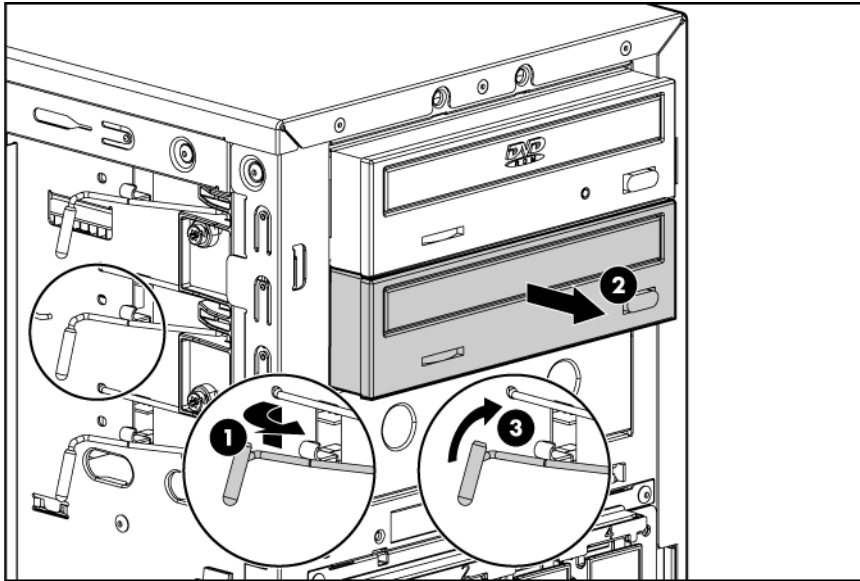

To replace the component, reverse the removal procedure.

Full-height tape drive

CAUTION: To prevent improper cooling and thermal damage, do not operate the server unless all bays are populated with either a component or a blank.

To remove the component:

1. Power down the server (on page 26).
2. Remove the bezel ("Bezel" on page 27).
3. Remove the access panel ("Access panel" on page 28).
4. Disconnect the power and data cables from the drive and the system board ("System board components" on page 68).

5. Remove the full-height tape drive.

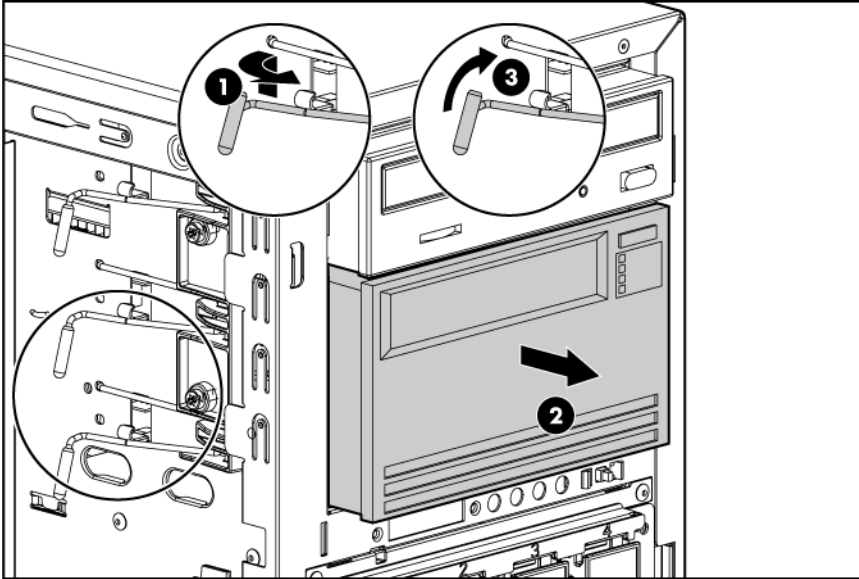

To replace the component, reverse the removal procedure.

USB tape drive

CAUTION: To prevent improper cooling and thermal damage, do not operate the server unless all bays are populated with either a component or a blank.

To remove the component:

1. Power down the server (on page 26).
2. Remove the bezel ("Bezel" on page 27).
3. Remove the access panel ("Access panel" on page 28).
4. Disconnect the USB tape drive cable from the drive and the system board ("System board components" on page 68).

5. Remove the USB tape drive.

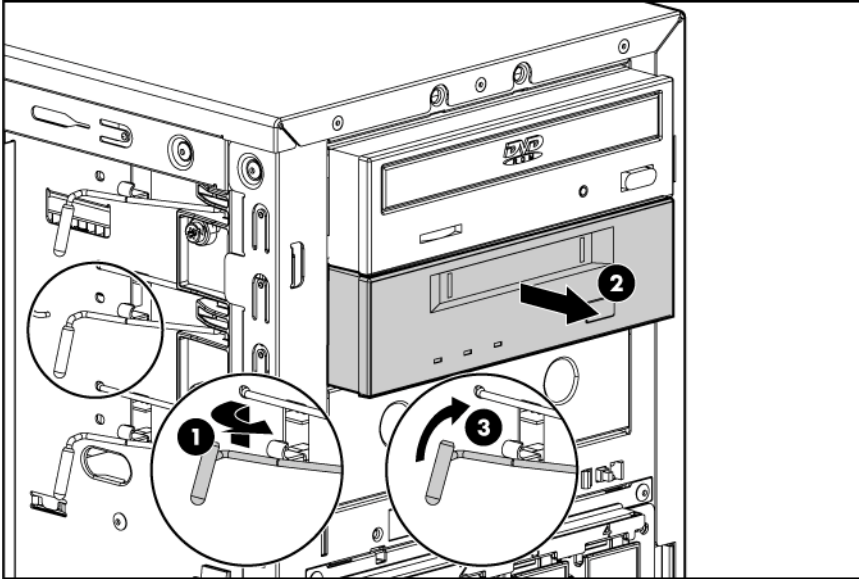

To replace the component, reverse the removal procedure.

Hard drive cage and hard drive backplane

To remove the component:

1. Power down the server (on page 26).
2. Remove the bezel ("Bezel" on page 27).
3. Remove the access panel ("Access panel" on page 28).
4. Remove all hot-plug hard drives ("Hard drives" on page 30).
5. Disconnect the power and data cables from the hard drive backplane and the system board ("System board components" on page 68).
6. Remove the hard drive cage and hard drive backplane.

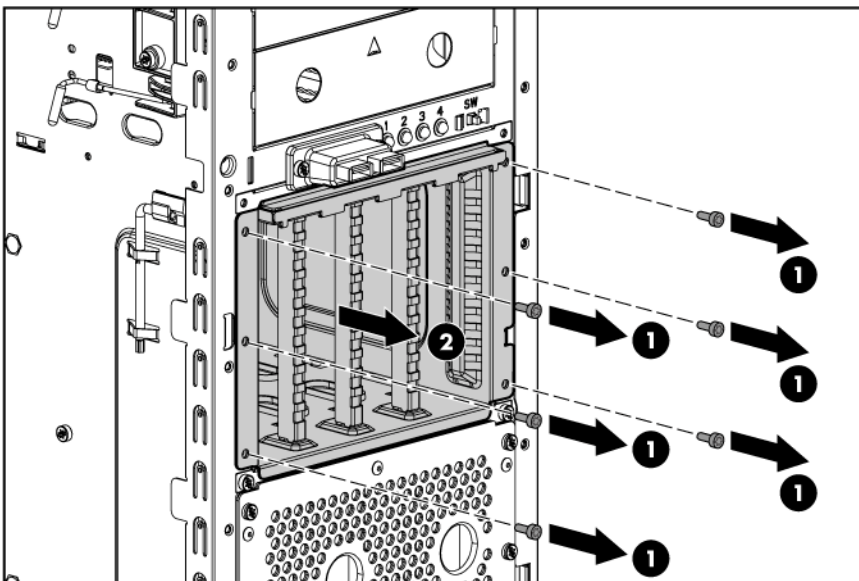

To replace the component, reverse the removal procedure.

Rear fan and fan holder

To remove the component:

1. Power down the server (on page 26).
2. Unlock the bezel (on page 27).
3. Remove the access panel ("Access panel" on page 28).
4. Remove the rear fan.

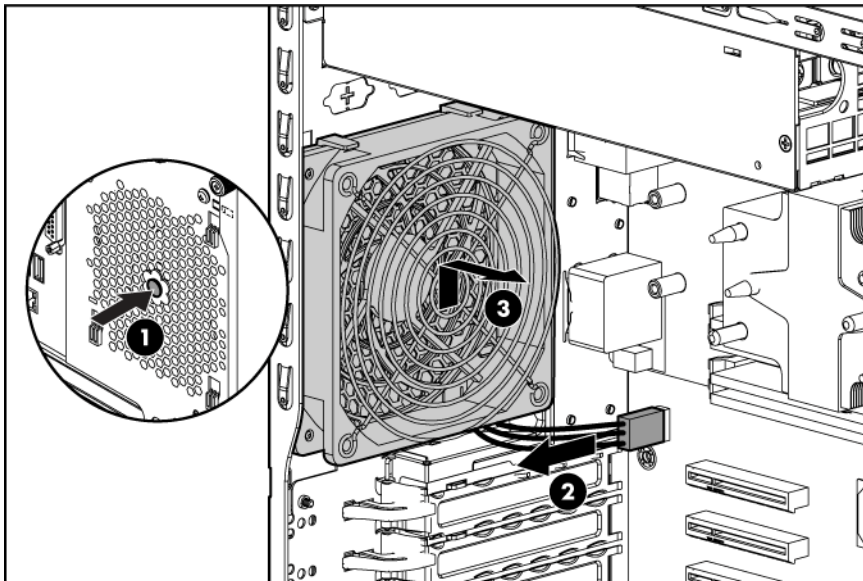

5. Remove the rear fan from the fan holder.

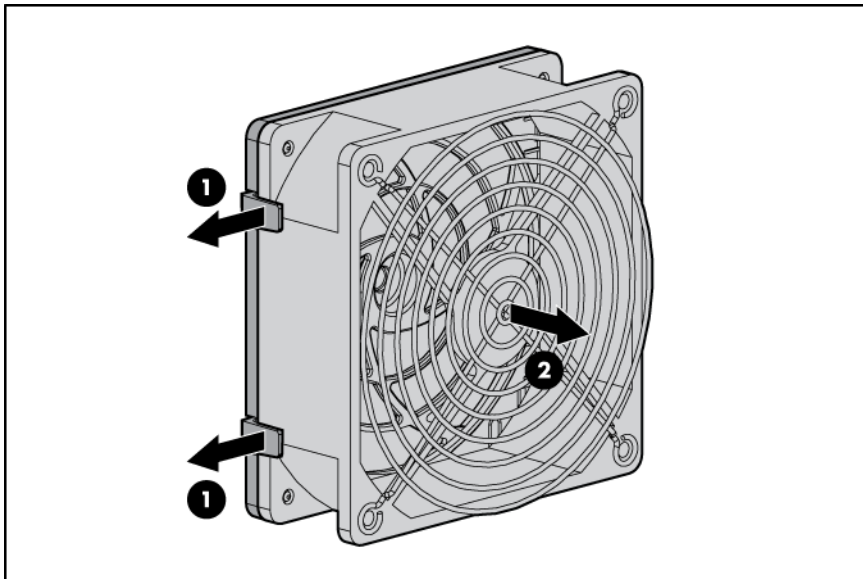

To replace the component, reverse the removal procedure.

System air baffle and PCI card guide

To remove the component:



WARNING: To reduce the risk of personal injury from hot surfaces, allow the drives and the internal system components to cool before touching them.



CAUTION: Do not operate the server for long periods with the access panel open or removed. Operating the server in this manner results in improper airflow and improper cooling that can lead to thermal damage.

1. Power down the server (on page 26).
2. Unlock the bezel (on page 27).
3. Remove the access panel ("Access panel" on page 28).
4. Remove any full-length expansion boards installed in slot 1, 3, or 5, if installed ("Expansion boards" on page 50).
5. Disconnect the PCI fan cable, if installed ("System board components" on page 68).
6. Remove the system air baffle and PCI card guide.

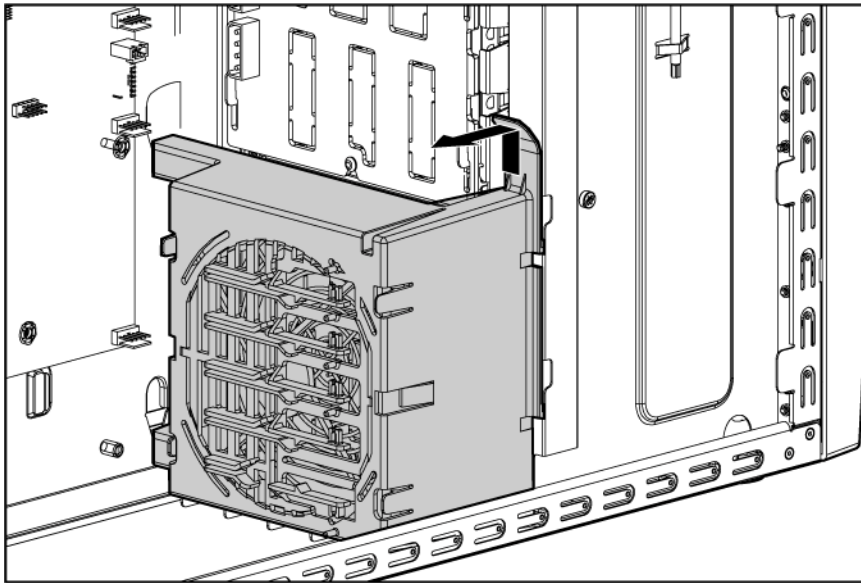

To replace the component, reverse the removal procedure.

PCI fan

To remove the component:

1. Power down the server (on page 26).
2. Unlock the bezel (on page 27).
3. Remove the access panel ("Access panel" on page 28).
4. Disconnect the PCI fan cable from the system board ("System board components" on page 68).
5. Remove the system air baffle and PCI card guide ("System air baffle and PCI card guide" on page 39).

6. Remove the PCI fan.

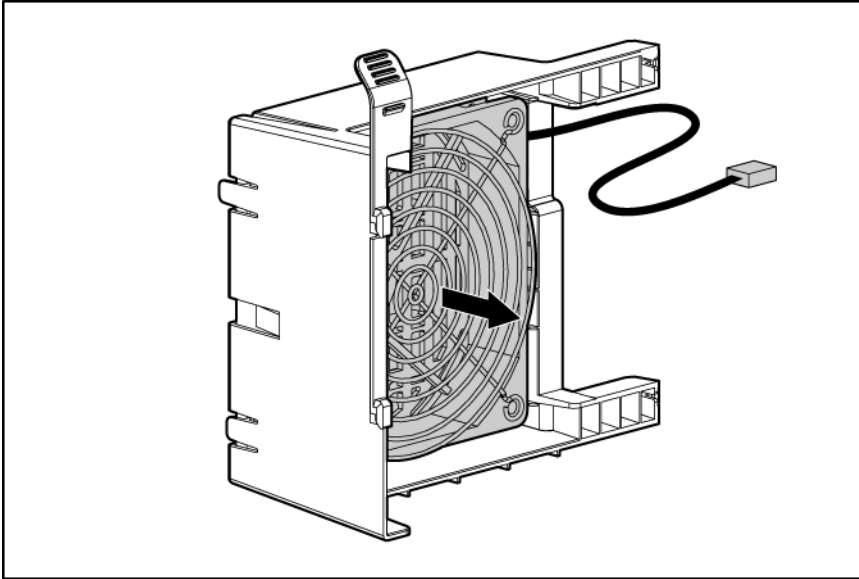

To replace the component, reverse the removal procedure.

Non-redundant power supply

To remove the component:

1. Power down the server (on page 26).
2. Unlock the bezel (on page 27).
3. Remove the access panel ("Access panel" on page 28).
4. Disconnect the power and signal cables from the system board ("System board components" on page 68).
5. Remove the power supply.

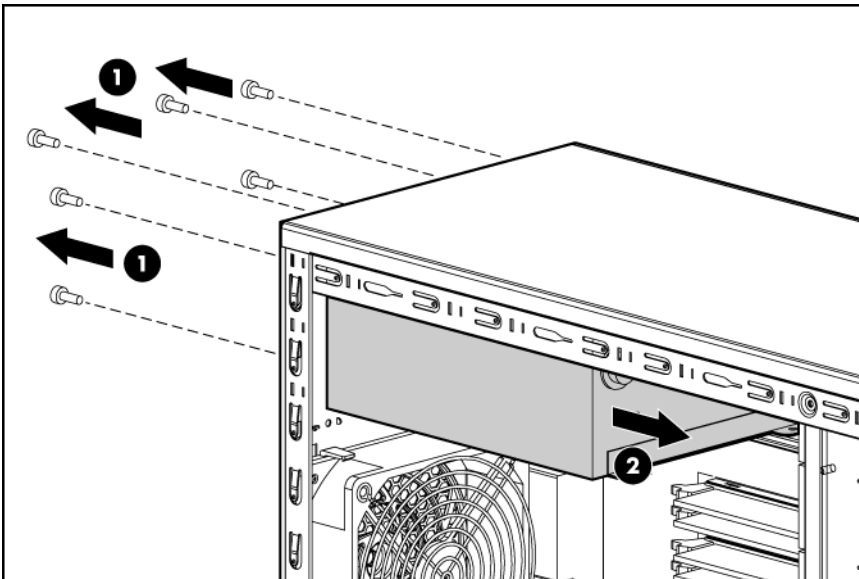

To replace the component, reverse the removal procedure.

Hot-plug power supply

△ **CAUTION:** Leave all failed power supplies installed until ready to replace with a working power supply.

1. Disconnect the power cord of the failed power supply from the AC power source.
2. Disconnect the power cord from the failed power supply.
3. Remove the power supply.

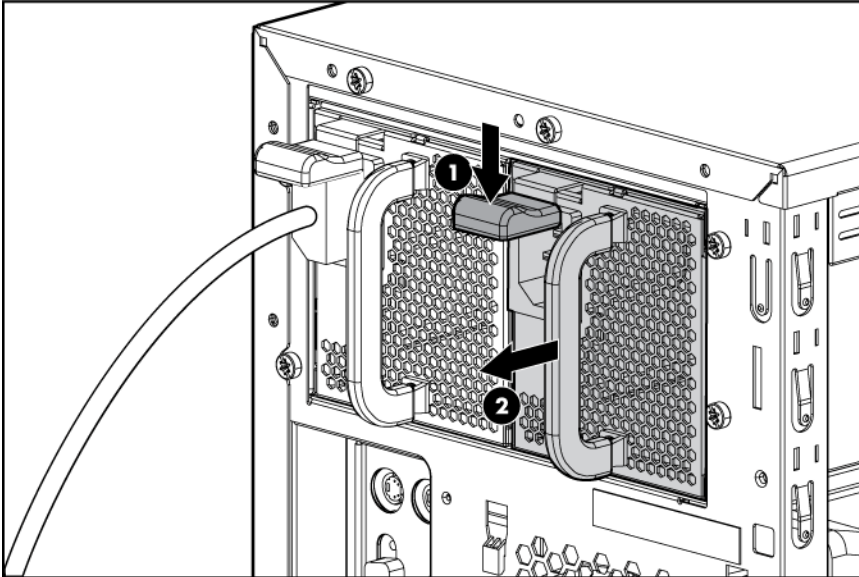

To replace the component, reverse the removal procedure.

Redundant power supply backplane assembly

To remove the component:

1. Power down the server (on page 26).
2. Unlock the bezel (on page 27).
3. Remove the access panel ("Access panel" on page 28).
4. Remove all power supplies ("Hot-plug power supply" on page 41).
5. Disconnect all power cables.

6. Remove the redundant power supply backplane assembly.

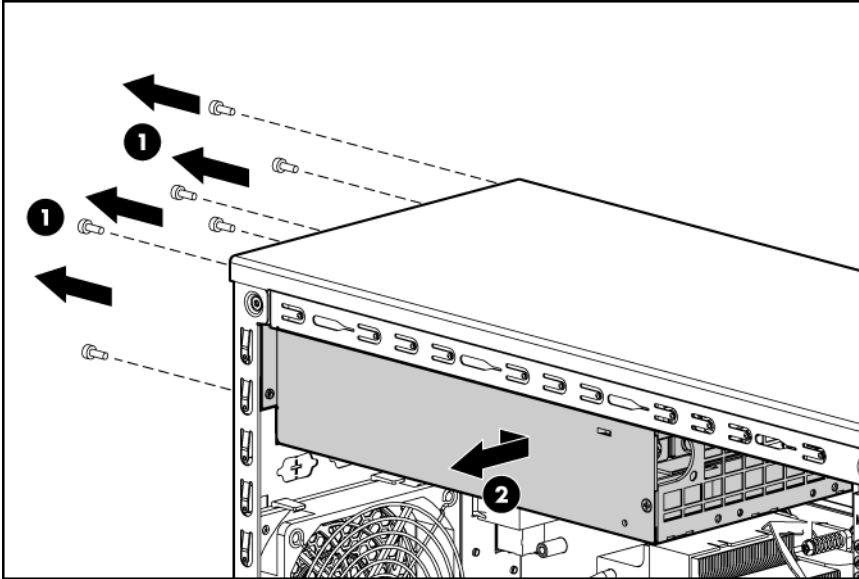

To replace the component, reverse the removal procedure.

DIMM

To remove the component:

1. Power down the server (on page 26).
2. Unlock the bezel (on page 27).
3. Remove the access panel ("Access panel" on page 28).
4. Remove the DIMM.

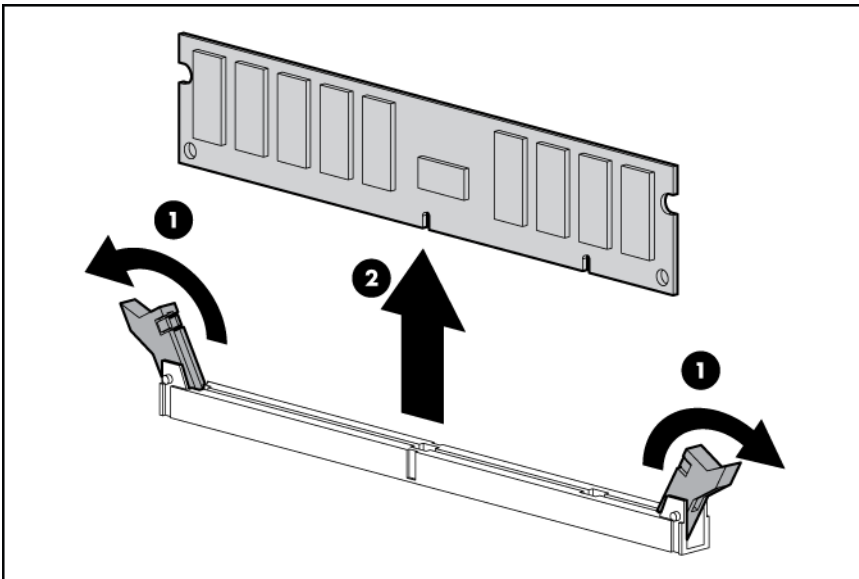

To replace the component, reverse the removal procedure.



IMPORTANT: DIMMs do not seat fully if turned the wrong way.

You can expand server memory by installing PC2-6400 DDR2 SDRAM DIMMs. The system supports up to four DIMMs for a maximum of 8 GB.

For DIMM slot locations and bank assignments, see "System board components (on page 68)."

Observe the following guidelines when installing additional memory:

- DIMMs installed in the server must be unbuffered DDR2 SDRAM with ECC.
- If only a single DIMM is installed, it must be installed in slot 1A.
- All DIMMs installed must be the same speed.

BIOS detects the DIMM population and sets the system as follows:

- Single-bank mode: Single DIMM installed in one bank only
- Single-bank interleaved mode: DIMMs installed in one bank with equal capacities per slot
- Dual-bank asymmetric mode: DIMMs installed in both banks, but of unequal capacities per bank
- Dual-bank interleaved mode: DIMMs installed in both banks with equal capacities per bank

The following table lists some, but not all, possible configurations. For best performance, HP recommends dual-bank interleaved mode configurations.

Slot 1A	Slot 2B	Slot 3A	Slot 4B	Total memory	Mode
512 MB	— — — 512			MB	Single-bank
512 MB	—	512 MB	—	1 GB	Single-bank interleaved
1 GB	— — — 1			GB	Single-bank
1 GB	—	1 GB	—	2 GB	Single-bank interleaved
2 GB	— — — 2			GB	Single-bank
2 GB	—	2 GB	—	4 GB	Single-bank interleaved
2 GB	2 GB	2 GB	—	6 GB	Dual-bank asymmetric
2 GB	2 GB	2 GB	2 GB	8 GB	Dual-bank interleaved

Heatsink

To remove the component:

1. Power down the server (on page 26).
2. Unlock the bezel (on page 27).
3. Remove the access panel ("Access panel" on page 28).
4. Disconnect the processor heatsink fan cable from the system board ("System board components" on page 68).
5. Remove the heatsink.



CAUTION: Heatsink retaining screws should be loosened in diagonally opposite pairs (in an "X" pattern).

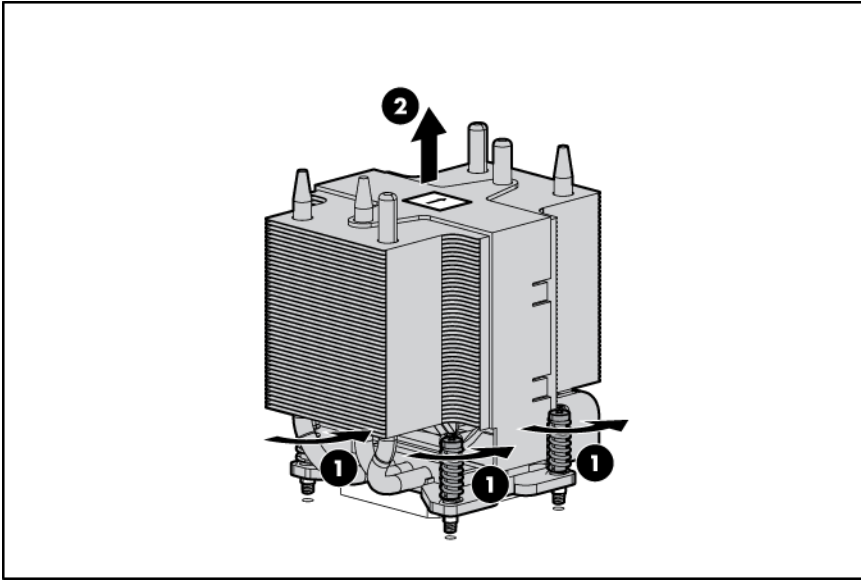

To replace the heatsink:

1. Use the alcohol swab to remove all the existing thermal grease from the processor. Allow the alcohol to evaporate before continuing.
2. Apply new grease to the top of the processor in one of the following patterns to ensure even distribution.

CAUTION: The heatsink thermal interface media is not reusable and must be replaced if the heatsink is removed from the processor after it has been installed.

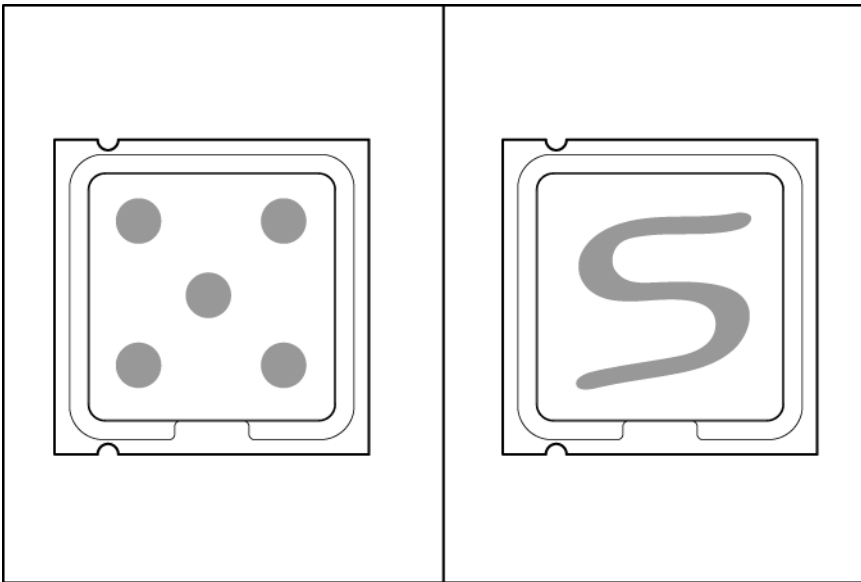

CAUTION: The heatsink is designed to fit one way in the server. Failure to install the heatsink properly can result in thermal damage or equipment failure.

CAUTION: Heatsink retaining screws should be tightened in diagonally opposite pairs (in an "X" pattern).

3. Align and install the heatsink with the arrow on the heatsink label pointing to the front of the server.

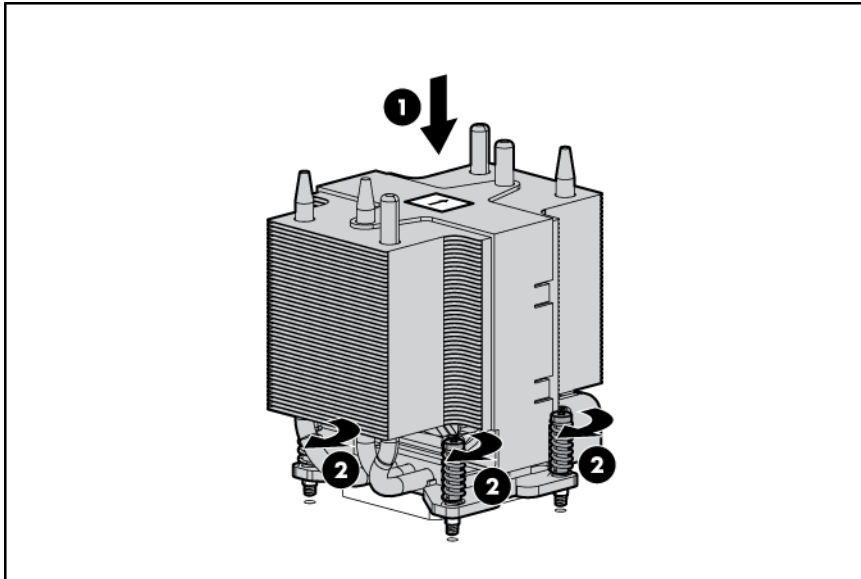

4. Connect the processor heatsink fan cable to the system board ("[System board components](#)" on page 68). When the heatsink is oriented properly, cable length is sufficient for the corresponding connector.
5. Install the access panel.
6. Lock the bezel.

Processor



CAUTION: Removal of the processor or heatsink renders the thermal layer between the processor and heatsink useless. Clean the component with the provided alcohol swab, then add thermal grease.



IMPORTANT: If upgrading processor speed, update the system ROM before installing the processor.

NOTE: PPM 1 is embedded in the system board.

To remove the component:

1. Power down the server (on page 26).
2. Unlock the bezel (on page 27).
3. Remove the access panel ("[Access panel](#)" on page 28).
4. Remove the heatsink ("[Heatsink](#)" on page 43).

5. Open the processor retaining latch and the processor socket retaining bracket.

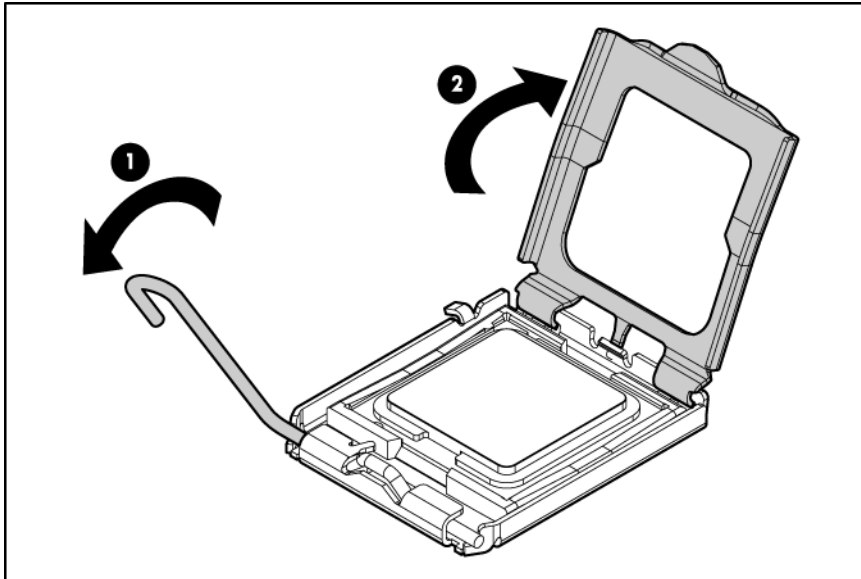

6. Using your fingers, remove the failed processor.

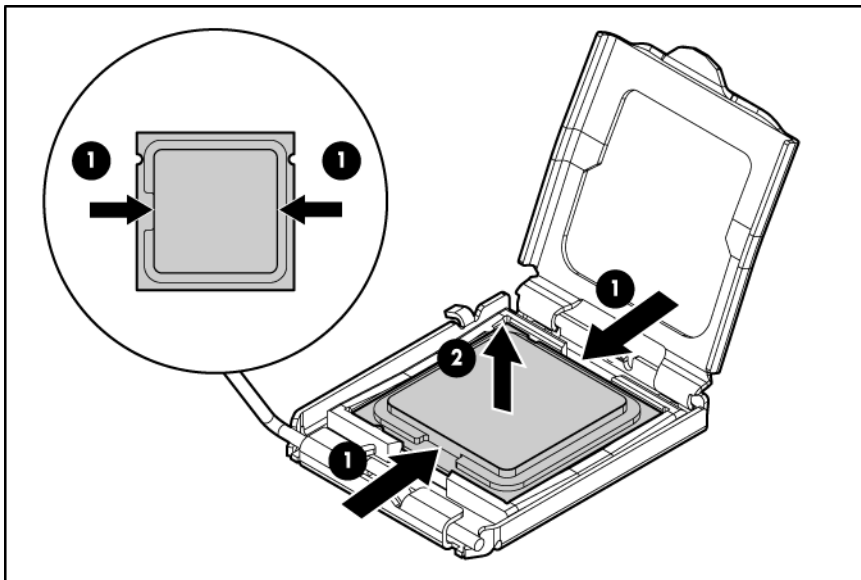

To replace the component:



IMPORTANT: Be sure the processor remains inside the processor installation tool.

1. If the processor has separated from the installation tool, carefully re-insert the processor in the tool.

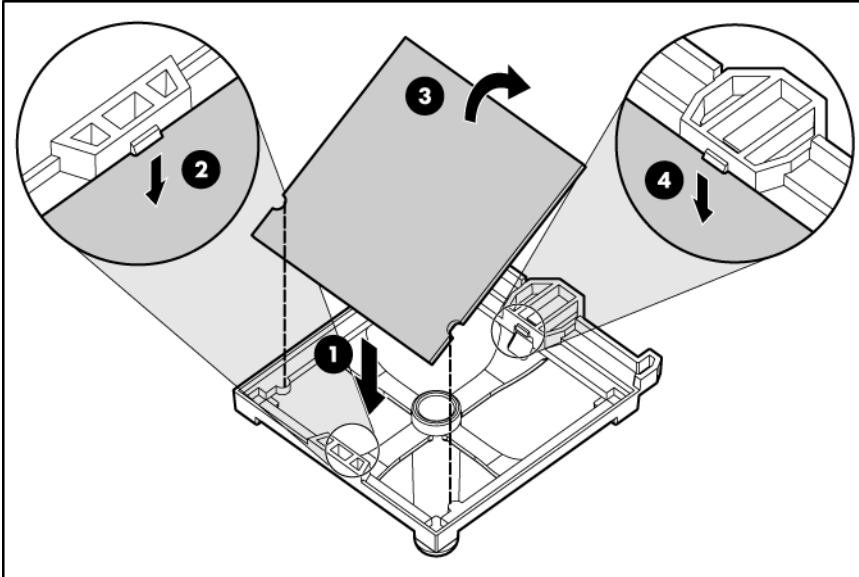

2. Align the processor installation tool with the socket and install the spare processor.

CAUTION: The processor is designed to fit one way into the socket. Use the alignment guides on the processor and socket to properly align the processor with the socket. Refer to the server hood label for specific instructions.

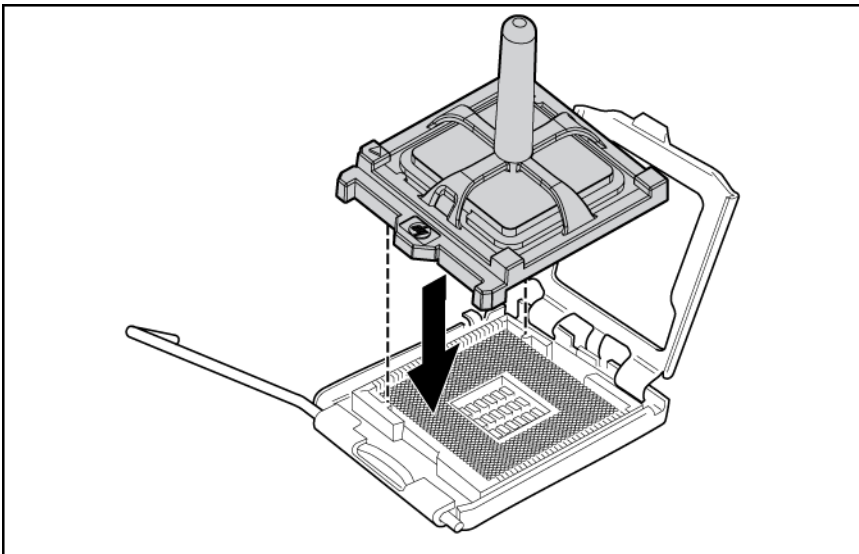

3. Press down firmly until the processor installation tool clicks and separates from the processor, and then remove the processor installation tool.

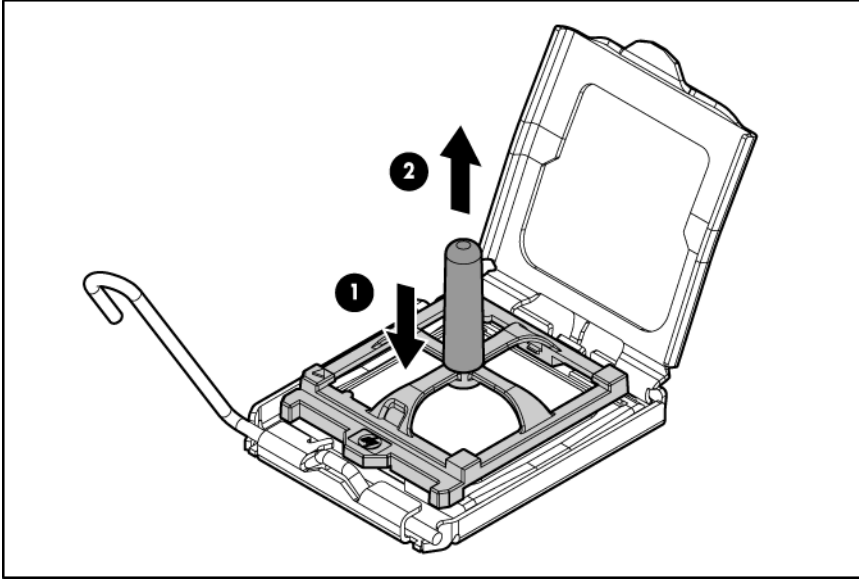

4. Close the processor retaining latch and the processor socket retaining bracket.

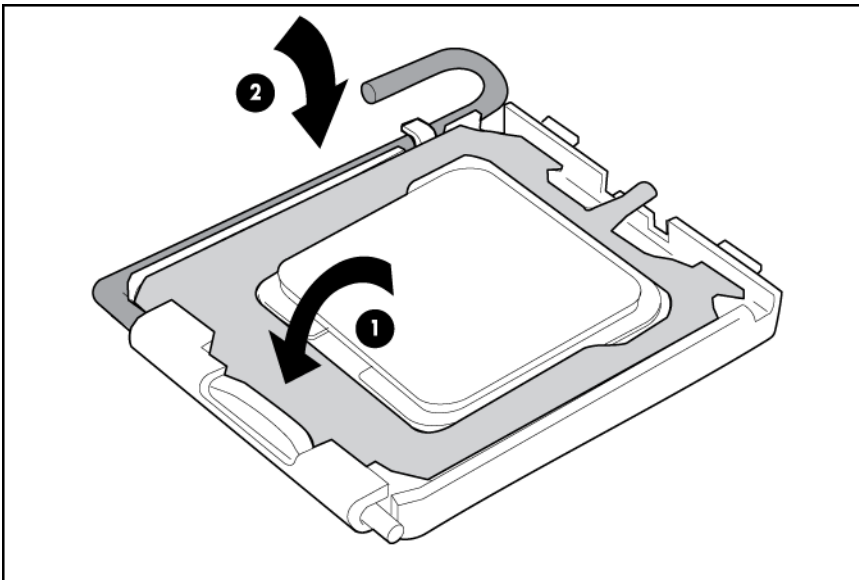

5. Clean the old thermal grease from the heatsink with the alcohol swab. Allow the alcohol to evaporate before continuing.

6. Apply all the grease to the top of the processor in one of the following patterns to ensure even distribution:

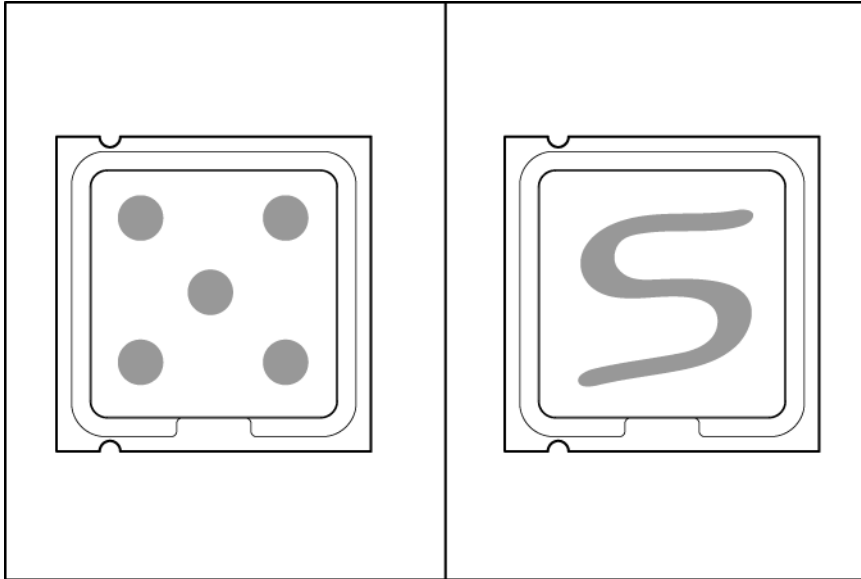

-
- ⚠ **CAUTION:** The heatsink is designed to fit one way in the server. Failure to install the heatsink properly can result in thermal damage or equipment failure.
-
- ⚠ **CAUTION:** Heatsink retaining screws should be tightened in diagonally opposite pairs (in an "X" pattern).
-

7. Align and install the heatsink with the arrow on the heatsink label pointing to the front of the server.

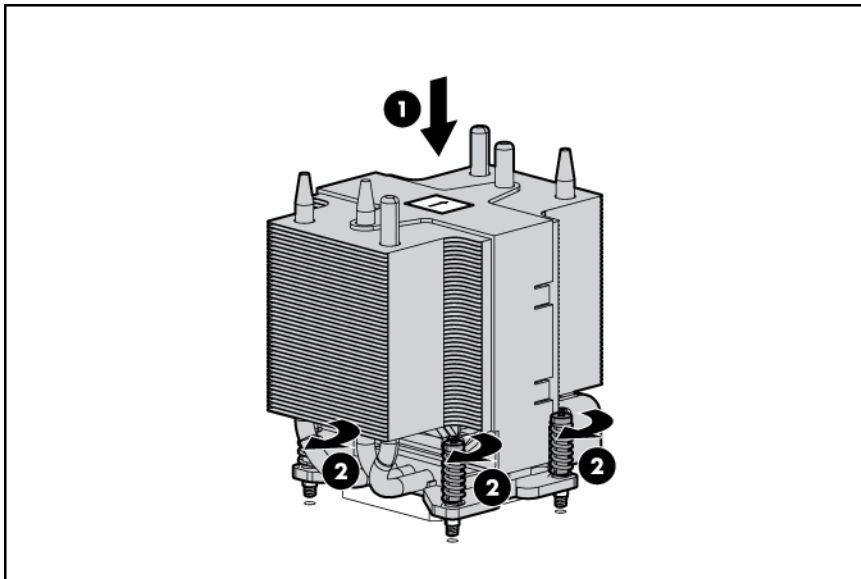

8. Connect the processor heatsink fan cable to the system board ("[System board components](#)" on page 68). When the heatsink is oriented properly, cable length is sufficient for the corresponding connector.
9. Install the access panel.
10. Lock the bezel.
11. Power up the server.

Expansion boards

To remove the component:

1. Power down the server (on page 26).
2. Unlock the bezel (on page 27).
3. Remove the bezel ("Bezel" on page 27).
4. Remove the access panel ("Access panel" on page 28).
5. Remove the expansion board.

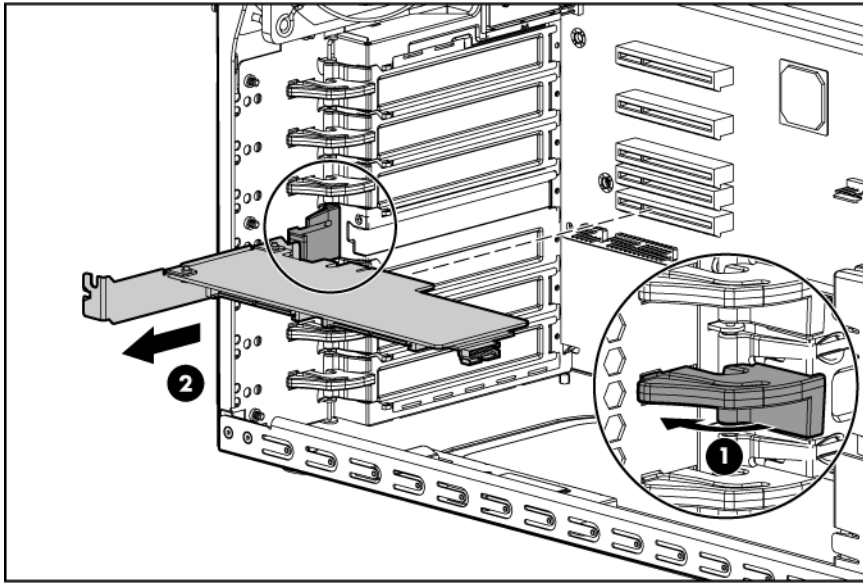

To replace the component, reverse the removal procedure.

PCI-X extender board

To remove the component:

1. Power down the server (on page 26).
2. Unlock the bezel (on page 27).
3. Remove the access panel ("Access panel" on page 28).
4. Remove the expansion board installed in slot 1, if installed ("Expansion boards" on page 50).
5. Remove the system air baffle and PCI card guide ("System air baffle and PCI card guide" on page 39).

6. Remove the PCI-X extender board.

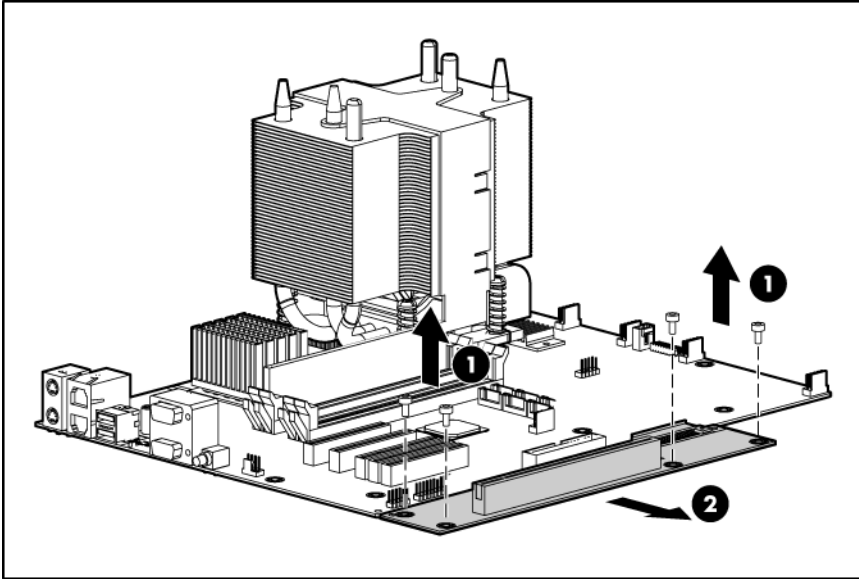

To replace the component, reverse the removal procedure.

Battery

If the server no longer automatically displays the correct date and time, you may need to replace the battery that provides power to the real-time clock. Under normal use, battery life is 5 to 10 years.



WARNING: The computer contains an internal lithium manganese dioxide, a vanadium pentoxide, or an alkaline battery pack. A risk of fire and burns exists if the battery pack is not properly handled. To reduce the risk of personal injury:

- Do not attempt to recharge the battery.
- Do not expose the battery to temperatures higher than 60°C (140°F).
- Do not disassemble, crush, puncture, short external contacts, or dispose of in fire or water.
- Replace only with the spare designated for this product.

To remove the component:

1. Power down the server (on page [26](#)).
2. Remove the bezel ("[Bezel](#)" on page [27](#)).
3. Remove the access panel ("[Access panel](#)" on page [28](#)).

4. Remove the battery.

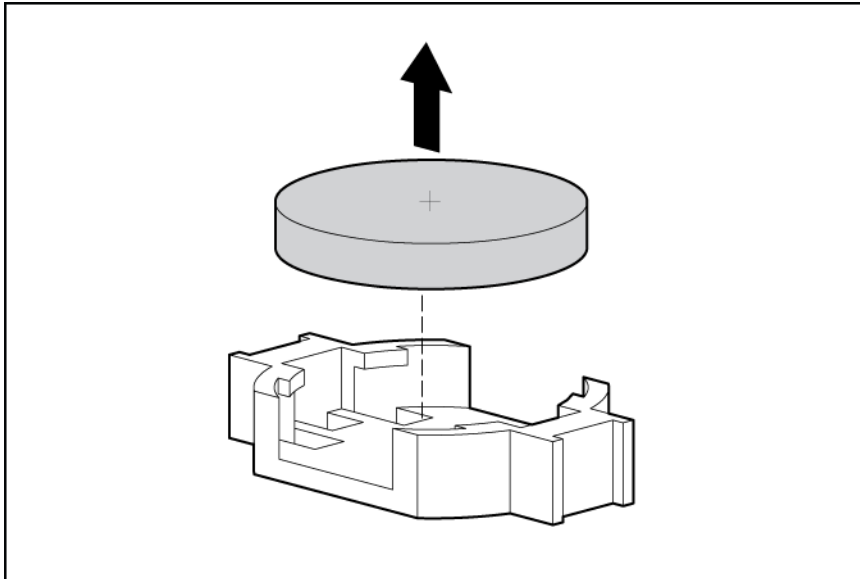

To replace the component, reverse the removal procedure.



IMPORTANT: After replacing the battery, the server is automatically configured with the default settings. The user can update these settings using RBSU.

For more information about battery replacement or proper disposal, contact an authorized reseller or an authorized service provider.

System board

To remove the component:

1. Power down the server (on page [26](#)).
2. Unlock the bezel (on page [27](#)).
3. Remove the access panel ("[Access panel](#)" on page [28](#)).
4. Remove all DIMMs ("[DIMM](#)" on page [42](#)).
5. Remove all PCI expansion boards ("[Expansion boards](#)" on page [50](#)).
6. Remove the system air baffle and PCI card guide ("[System air baffle and PCI card guide](#)" on page [39](#)).
7. Remove the PCI-X extender board, if installed ("[PCI-X extender board](#)" on page [50](#)).
8. Disconnect all cables from the system board ("[System board components](#)" on page [68](#)).
9. Remove the heatsink.



CAUTION: Heatsink retaining screws should be loosened in diagonally opposite pairs (in an "X" pattern).

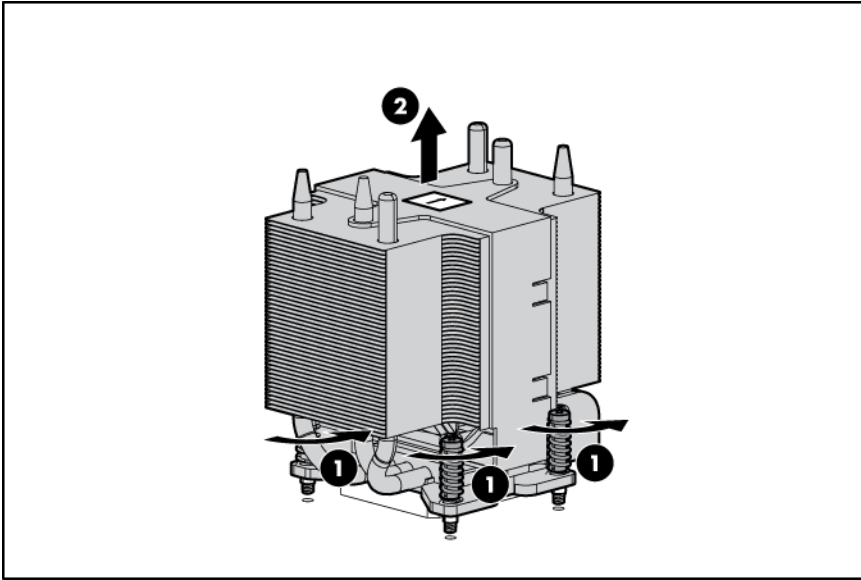

10. Open the processor retaining latch and the processor socket retaining bracket.

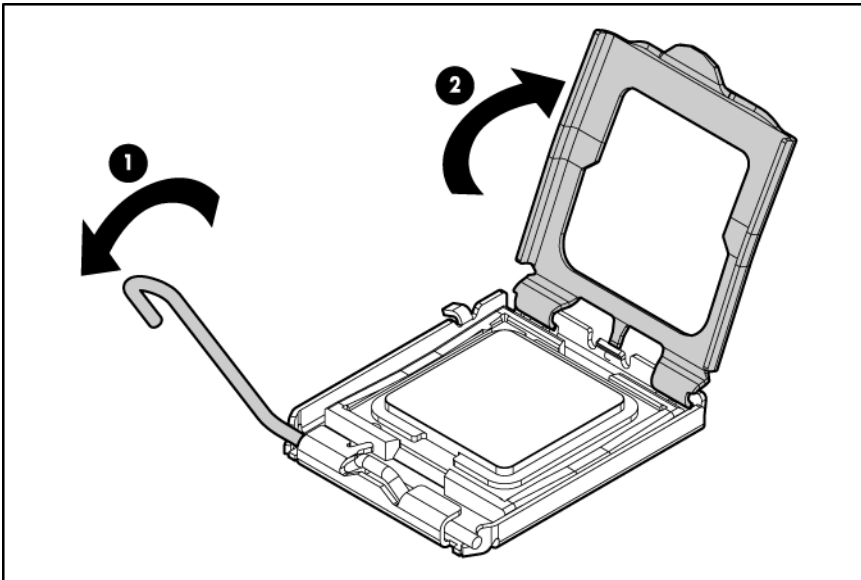

CAUTION: To avoid damage to the processor:

- Handle the processor only by the edges.
- Do not touch the bottom of the processor, especially the contact area.

11. Using your fingers, remove the processor from the failed system board.

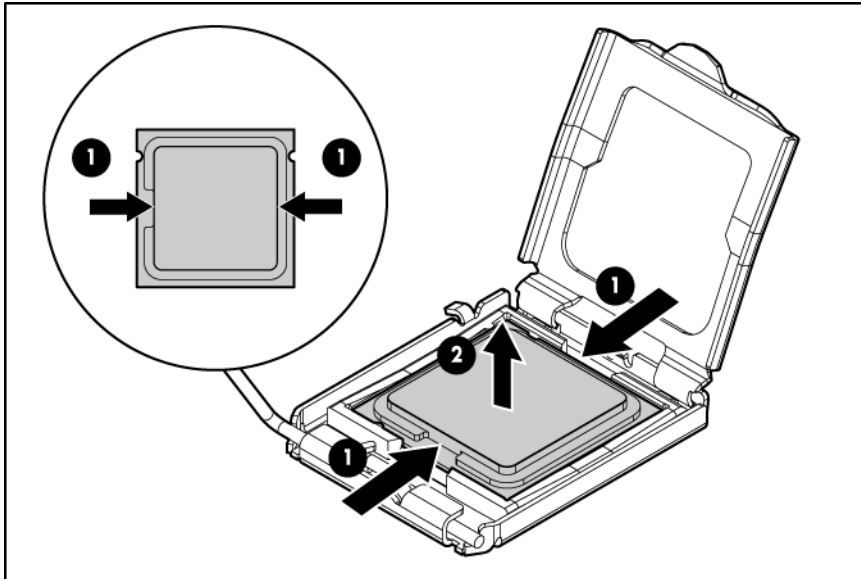

⚠ CAUTION: To avoid damage to the system board:

- Do not touch the processor socket contacts.
- Always install the processor socket cover after removing the processor from the socket.
- Do not tilt or slide the processor when lowering the processor into the socket.

12. Remove the failed system board.

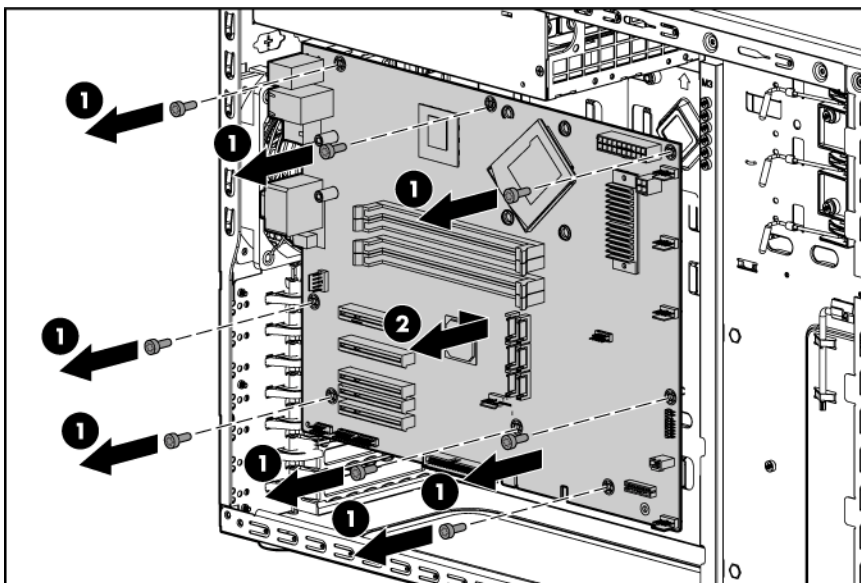

To replace the system board:

1. Install the spare system board in the server before installing the processor.
2. Prepare the processor socket on the spare system board:

- a. Open the processor retaining latch and the processor socket retaining bracket.

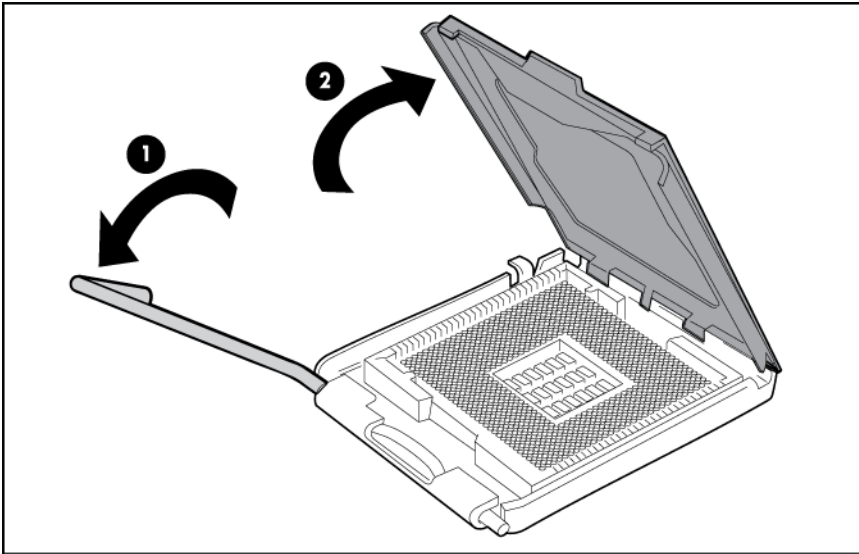

- b. Remove the processor socket protective cover.

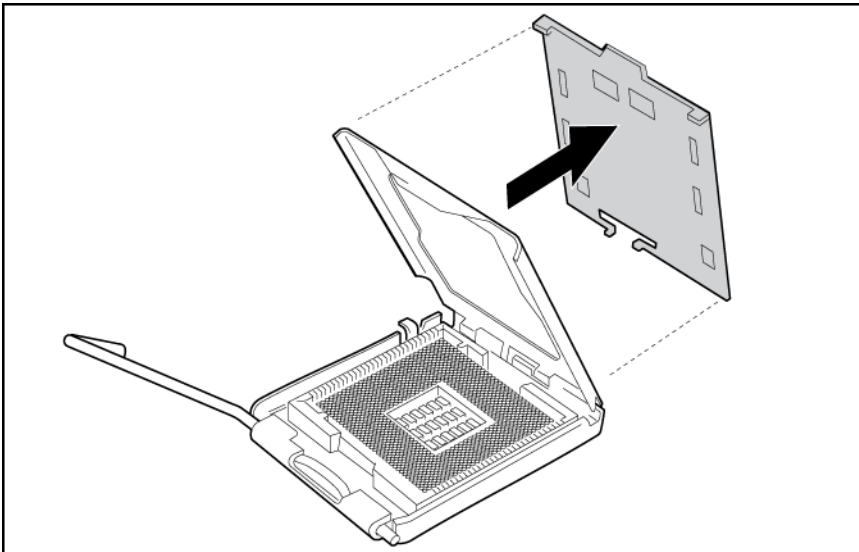

3. Install the processor socket cover onto the processor socket of the failed system board.
4. Install the processor on the spare system board.

△ **CAUTION:** The processor is designed to fit one way into the socket. Use the alignment guides on the processor and socket to properly align the processor with the socket. Refer to the server hood label for specific instructions.

△ **CAUTION:** Always install the processor parallel to the system board to avoid damage to the pins.

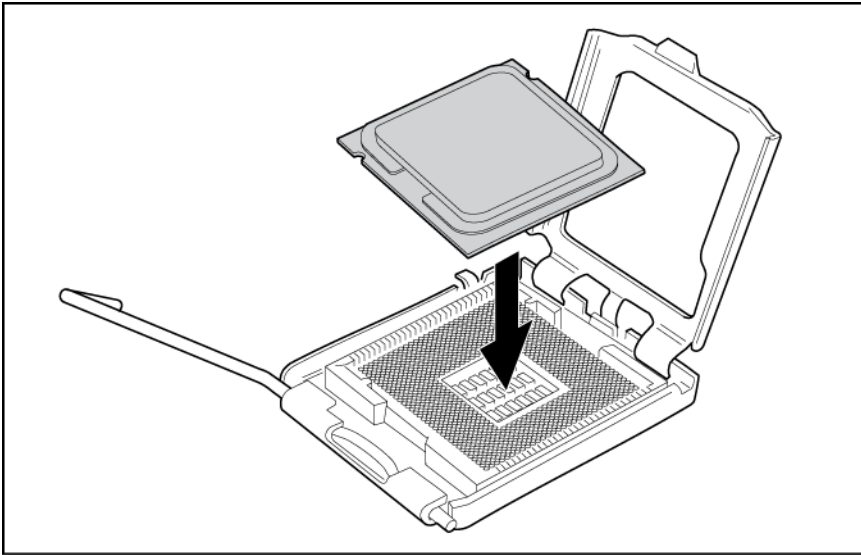

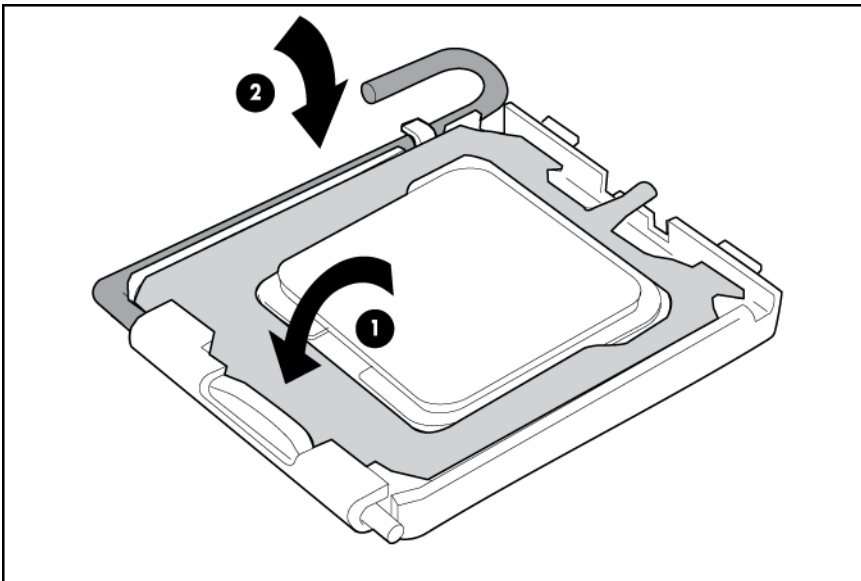

5. Close the processor retaining latch and the processor socket retaining bracket.

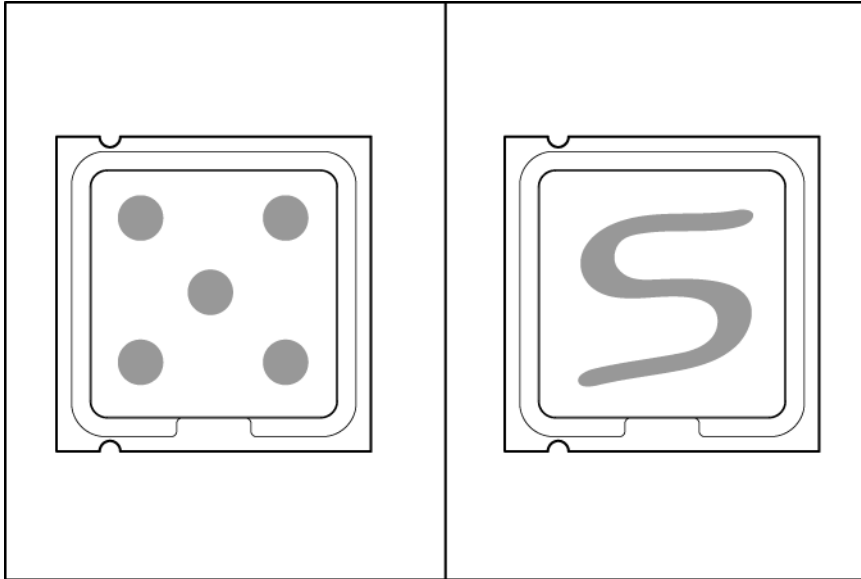

6. Clean the old thermal grease from the heatsink and the top of the processor with the alcohol swab. Allow the alcohol to evaporate before continuing.

7. Apply all the grease to the top of the processor in one of the following patterns to ensure even distribution:



-
-  **CAUTION:** The heatsink is designed to fit one way in the server. Failure to install the heatsink properly can result in thermal damage or equipment failure.
-
-  **CAUTION:** Heatsink retaining screws should be tightened in diagonally opposite pairs (in an "X" pattern).
-

8. Align and install the heatsink with the arrow on the heatsink label pointing to the front of the server.

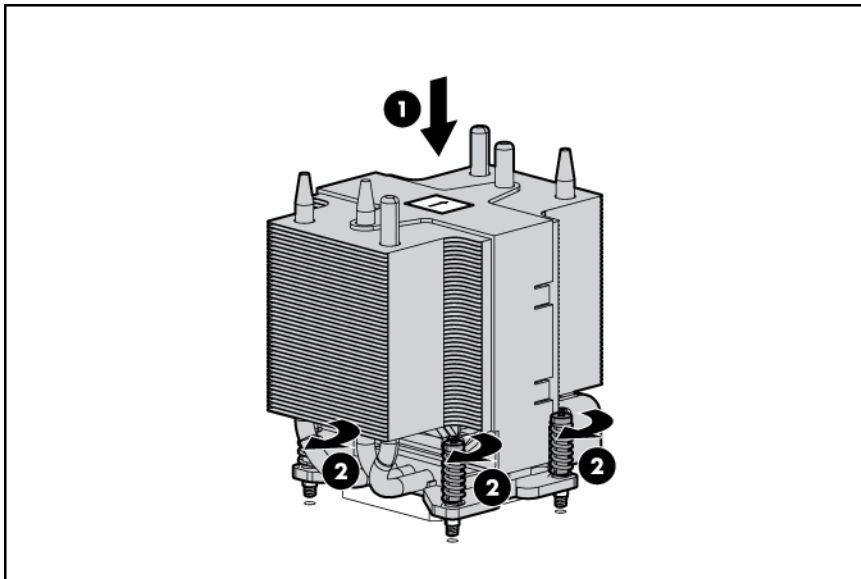

9. Connect the processor heatsink fan cable to the system board ("[System board components](#)" on page 68). When the heatsink is oriented properly, cable length is sufficient for the corresponding connector.

-  **IMPORTANT:** Install all components with the same configuration that was used on the failed system board.
-

10. Install all components removed from the failed system board.
11. Install the access panel.
12. Lock the bezel.
13. Power up the server.

After you replace the system board, you must re-enter the server serial number and the product ID.

1. During the server startup sequence, press the **F9** key to access RBSU.
2. Select the **Advanced Options** menu.
3. Select **Serial Number**. The following warning is displayed:
Warning: The serial number should ONLY be modified by qualified service personnel. This value should always match the serial number located on the chassis.
4. Press the **Enter** key to clear the warning.
5. Enter the serial number.
6. Select **Product ID**. The following warning is displayed.
Warning: The Product ID should ONLY be modified by qualified service personnel. This value should always match the Product ID located on the chassis.
7. Enter the product ID and press the **Enter** key.
8. Press the **Esc** key to close the menu.
9. Press the **Esc** key to exit RBSU.
10. Press the **F10** key to confirm exiting RBSU. The server will automatically reboot.

Server feet

This procedure applies to tower servers only.

To remove the component:

1. Power down the server (on page 26).
2. Place the server on its side on a flat, level surface.
3. Remove the screws securing each of the server feet.
4. Remove the server feet.

To replace the component, reverse the removal procedure.

Cabling

Server cabling

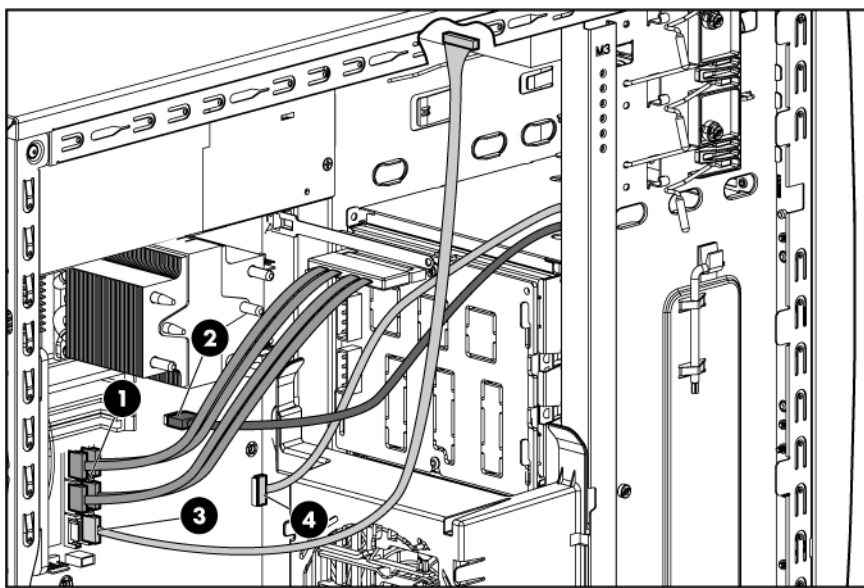

Item	Description
1	SATA hard drive cable (hard drive)
2	Front USB cable
3	SATA optical drive cable
4	Front panel LED cable

SATA hard drive cabling

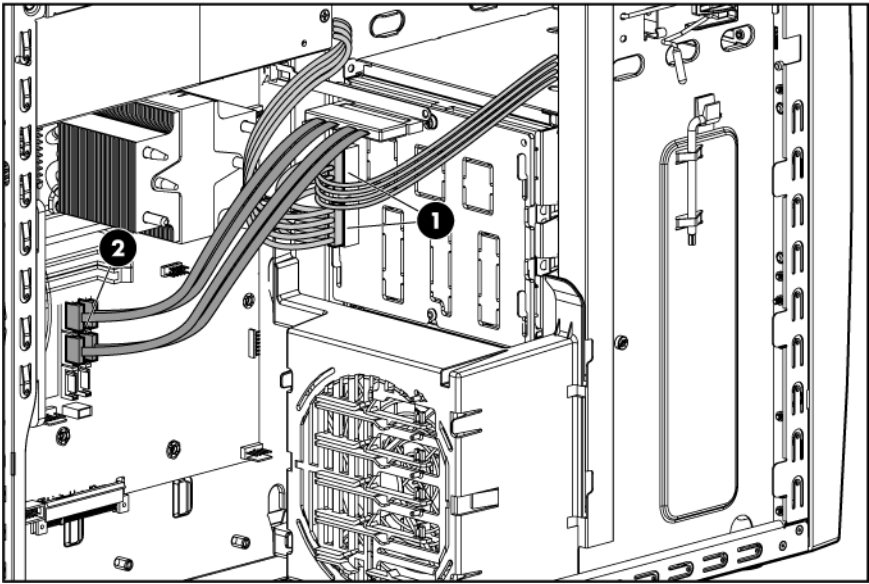

Item	Description
1 Power	cable
2 SATA	cable

SAS hard drive cabling

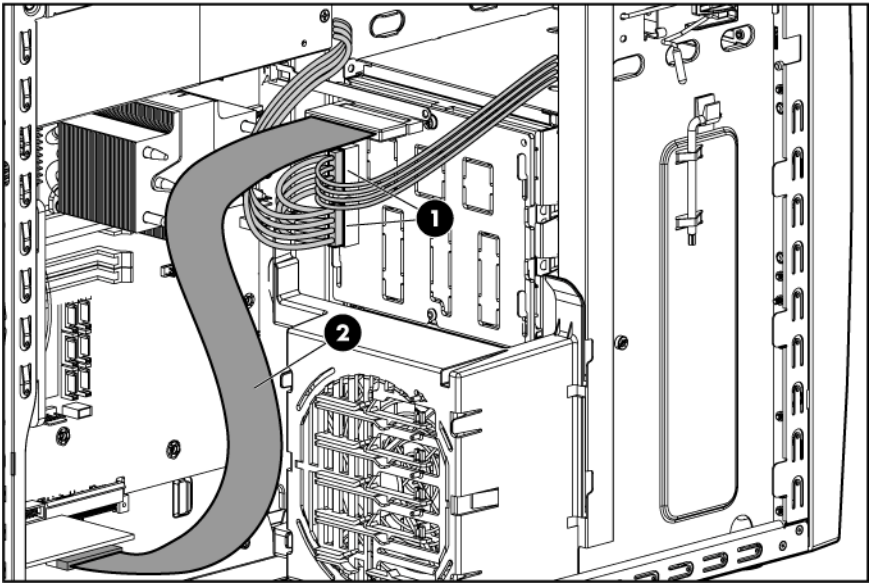

Item	Description
1 Power	cable
2 SAS	cable

Diagnostic tools

Troubleshooting resources

The *HP ProLiant Servers Troubleshooting Guide* provides procedures for resolving common problems and comprehensive courses of action for fault isolation and identification, error message interpretation, issue resolution, and software maintenance on ProLiant servers and server blades. This guide includes problem-specific flowcharts to help you navigate complex troubleshooting processes. To view the guide, select a language:

- English (http://www.hp.com/support/ProLiant_TSG_en)
- French (http://www.hp.com/support/ProLiant_TSG_fr)
- Italian (http://www.hp.com/support/ProLiant_TSG_it)
- Spanish (http://www.hp.com/support/ProLiant_TSG_sp)
- German (http://www.hp.com/support/ProLiant_TSG_gr)
- Dutch (http://www.hp.com/support/ProLiant_TSG_nl)
- Japanese (http://www.hp.com/support/ProLiant_TSG_jp)

HP Insight Diagnostics

HP Insight Diagnostics is a proactive server management tool, available in both offline and online versions, that provides diagnostics and troubleshooting capabilities to assist IT administrators who verify server installations, troubleshoot problems, and perform repair validation.

HP Insight Diagnostics Offline Edition performs various in-depth system and component testing while the OS is not running. To run this utility, launch the SmartStart CD.

HP Insight Diagnostics Online Edition is a web-based application that captures system configuration and other related data needed for effective server management. Available in Microsoft® Windows® and Linux versions, the utility helps to ensure proper system operation.

For more information or to download the utility, refer to the HP website (<http://www.hp.com/servers/diags>).

HP Insight Diagnostics survey functionality

HP Insight Diagnostics (on page 61) provides survey functionality that gathers critical hardware and software information on ProLiant servers.

This functionality supports operating systems that may not be supported by the server. For operating systems supported by the server, see the HP website (<http://www.hp.com/go/supportos>).

If a significant change occurs between data-gathering intervals, the survey function marks the previous information and overwrites the survey data files to reflect the latest changes in the configuration.

Survey functionality is installed with every SmartStart-assisted HP Insight Diagnostics installation, or it can be installed through the HP PSP.

NOTE: The current version of SmartStart provides the memory spare part numbers for the server. To download the latest version, see the HP website (<http://www.hp.com/support>).

Integrated Management Log

The IML records hundreds of events and stores them in an easy-to-view form. The IML timestamps each event with 1-minute granularity.

You can view recorded events in the IML in several ways, including the following:

- From within HP SIM
- From within Survey Utility
- From within operating system-specific IML viewers
 - For NetWare: IML Viewer
 - For Windows®: IML Viewer
 - For Linux: IML Viewer Application
- From within the iLO 2 user interface
- From within HP Insight Diagnostics (on page 61)

For more information, refer to the Management CD in the HP ProLiant Essentials Foundation Pack.

ROMPaq disaster recovery

If the current version of the ROM is corrupt, perform ROMPaq disaster recovery procedures:

1. Create a ROMPaq diskette using the Autorun Menu on the SmartStart CD.
2. Power down the server (on page 26).
3. Insert the ROMPaq diskette.
4. Power up the server.
 - a. The server generates one long beep and two short beeps to indicate that you are in disaster recovery mode. If the diskette is not in place, the system continues to beep until a valid ROMPaq diskette is inserted.
 - b. The ROMPaq diskette flashes the system ROM image. If successful, a sequence of ascending audible beeps is generated. If unsuccessful, a sequence of descending audible beeps is generated and you need to repeat the disaster recovery process.
5. Power down the server (on page 26).
6. Remove the ROMPaq diskette.
7. Power up the server.

Component identification

Front panel components

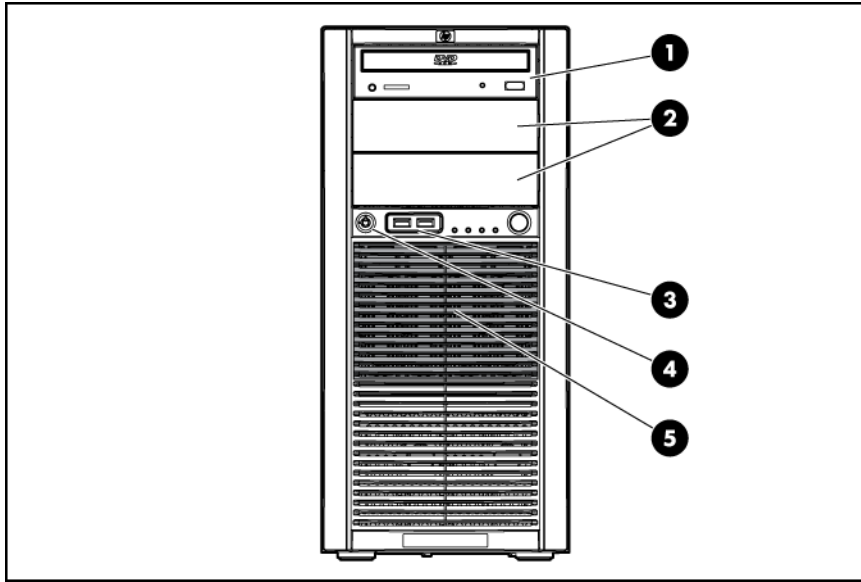

Item	Description
1	DVD-ROM drive
2	Media bays (bezel blanks)
3	USB connectors (2)
4	Bezel lock
5	Hard drive bays

Front panel LEDs and buttons

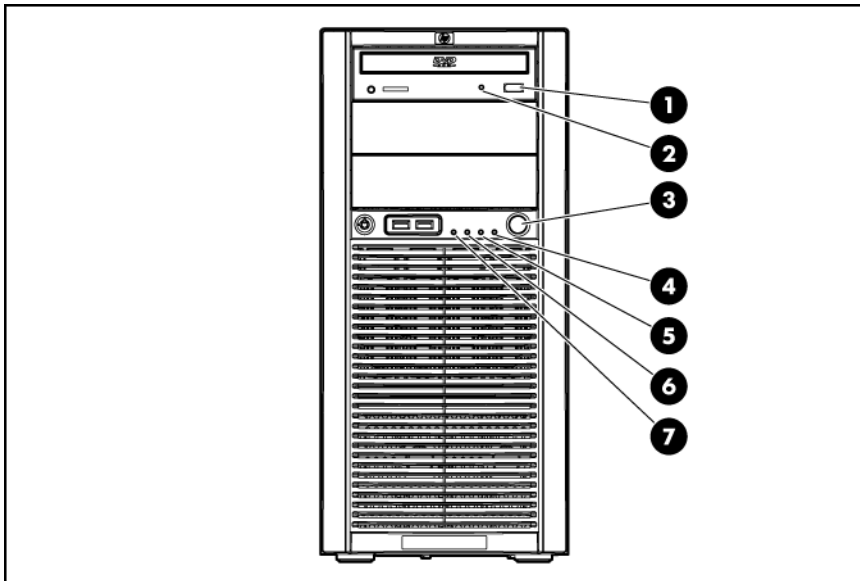

Item	Description	Status
1	DVD-ROM drive ejector button	—
2	DVD-ROM drive activity LED	On = Activity Off = No activity
3	Power On/Standby button	—
4	System power LED	Green = AC power is functioning Amber = AC power is in standby mode Off = AC power is not available
5	Hard drive activity LED	Green = Activity Off = No activity
6	NIC link/activity LED	Green = Linked Flashing green = Linked with activity on the network Off = No network link
7	Internal health LED*	Green = System health is OK Amber = System health is degraded Red = System health is critical Off = Normal (when in standby mode)

* For servers with redundant hot-plug power supplies, the internal health LED also signals a power supply event ("Rear panel LEDs" on page 67).

SAS and SATA device numbers

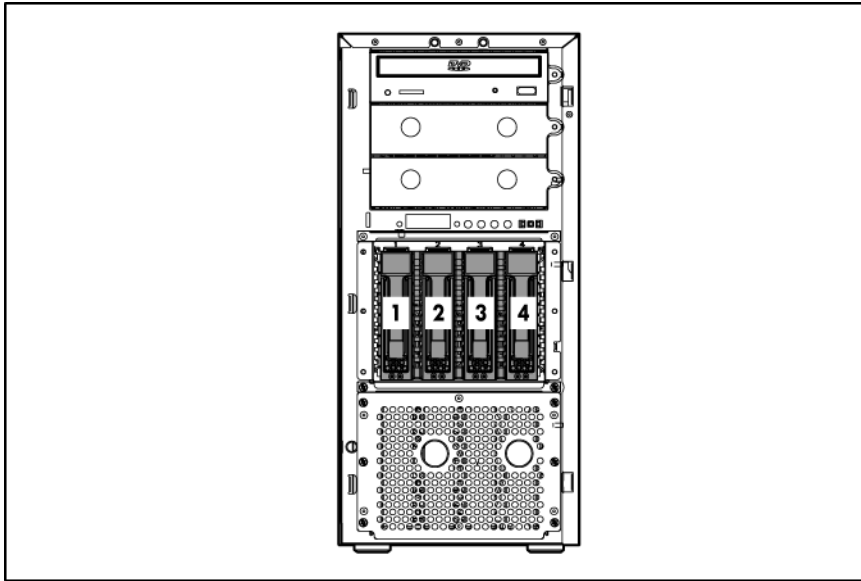

Hot-plug SATA or SAS hard drive LEDs

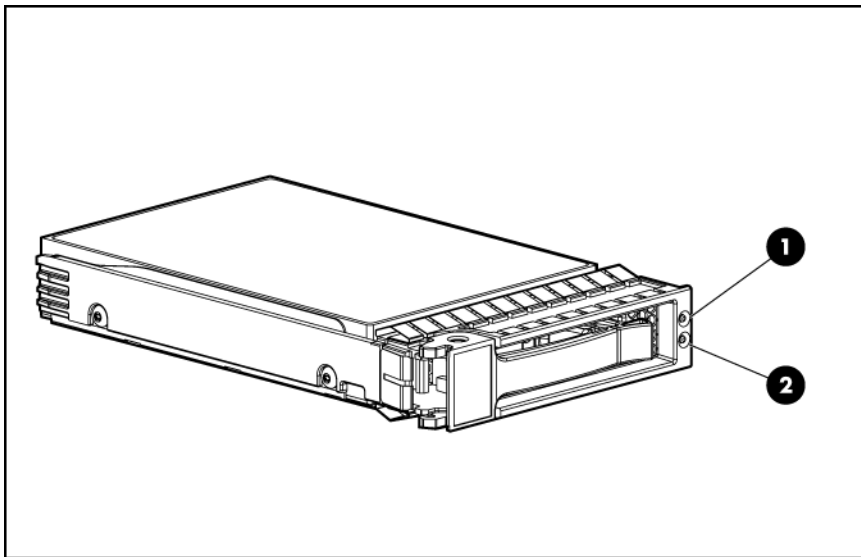

Item	LED description	Status
1	Fault/UID status	Amber = Drive failure Flashing amber = Fault-process activity Blue = Unit identification is active Off = No fault-process activity
2	Online/Activity status	Green = Drive activity Flashing green = High activity on the drive or drive is being configured as part of an array Off = No drive activity

The online/activity status LED will not illuminate if using SATA drives connected to the embedded storage device. In this configuration, SATA hard drive activity can be identified using the hard drive activity LED on the system front panel.

Rear panel components

The server may look different from that shown.

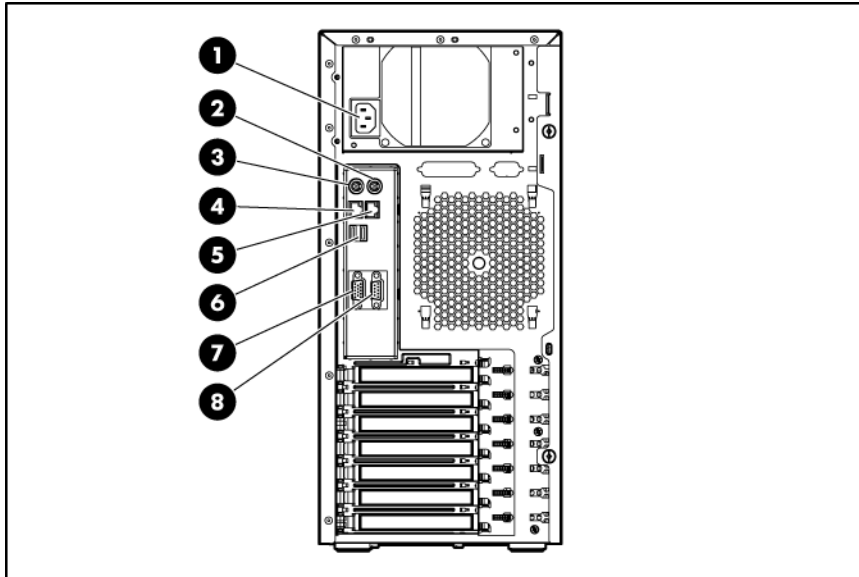

Item	Description
1	Power supply connector
2 Mouse	connector
3 K	eyboard connector
4	10/100/1000 NIC 1 connector
5	iLO 2 management port
6	USB connectors (2)
7 V	ideo connector
8 Seria	l connector

Rear panel LEDs

- Redundant hot-plug power supply model

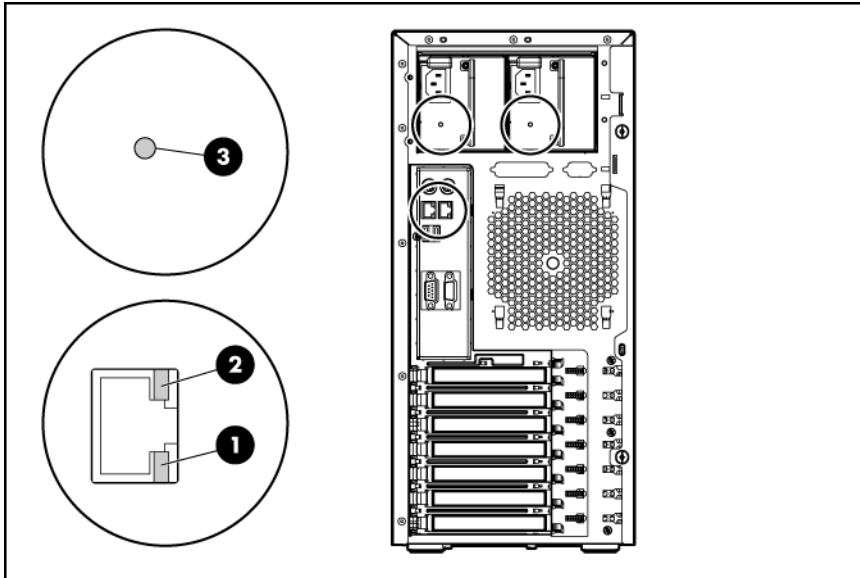

Item	LED	Status
1	NIC/iLO 2 link	On = Link Off = No link
2	NIC/iLO 2 activity	Flashing = Activity Off = No activity
3 Redundant	power supply	Green = Power supply is on and functioning Off = Power supply is not connected or power supply fault

- Non-redundant non-hot-plug power supply model

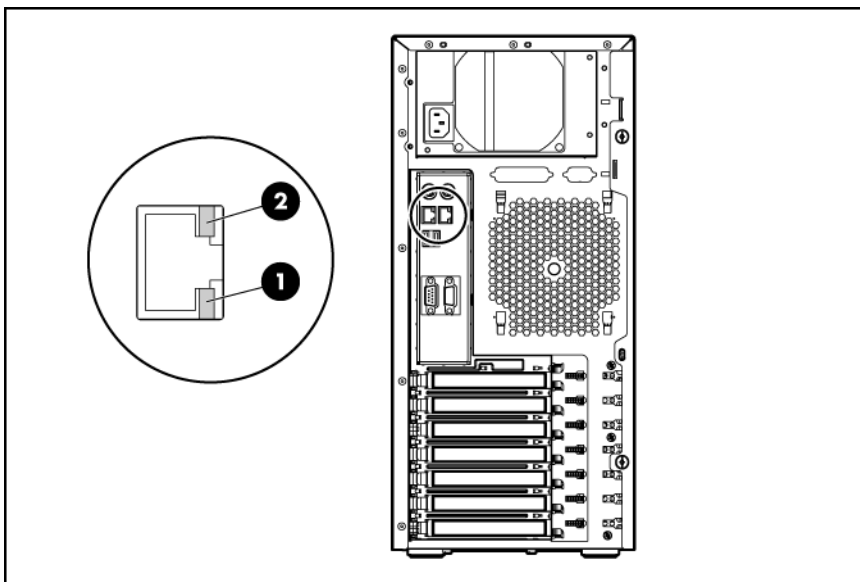

Item	LED	Status
1	NIC/iLO 2 link	On = Link Off = No link
2	NIC/iLO 2 activity	Flashing = Activity Off = No activity

System board components

For this server, some system board slots and connectors are reserved.

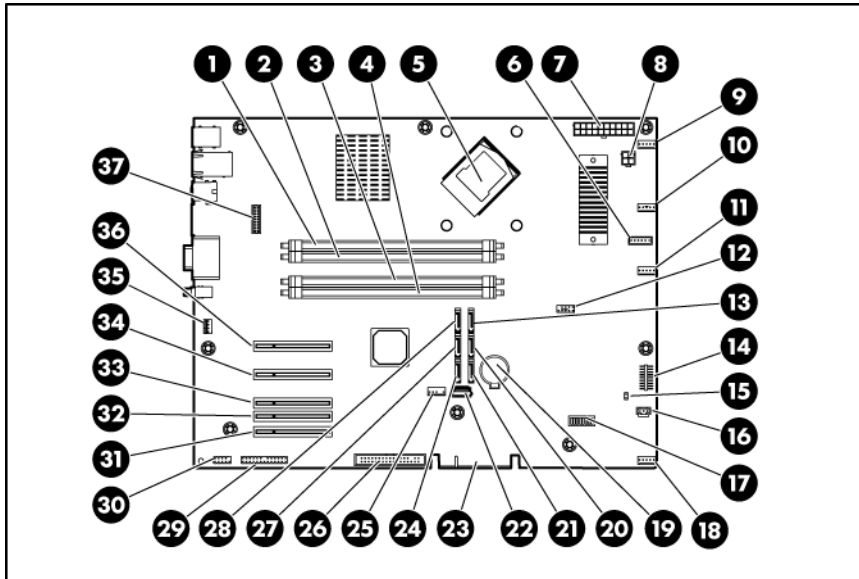

Item	Description
1	DIMM slot 1 (bank A)
2	DIMM slot 2 (bank B)
3	DIMM slot 3 (bank A)
4	DIMM slot 4 (bank B)
5	Processor socket
6	Redundant power supply connector
7	System power connector
8	Processor power connector
9	Processor heatsink fan connector
10	Reserved
11	Reserved
12	Front USB cable connector
13	SATA connector 2 (hard drive)
14	Front panel LED cable connector
15	NMI jumper
16	Temperature sensor connector

Item	Description
17	System maintenance switch
18	PCI fan connector
19	System battery
20	SATA connector 4 (hard drive)
21	SATA connector 6 (optical drive)
22	Internal USB connector
23	PCI-X extender board connector
24	SATA connector 5 (optical drive)
25	USB tape drive connector
26	Diskette drive connector
27	SATA connector 3 (hard drive)
28	SATA connector 1 (hard drive)
29	Parallel connector
30	Serial connector
31	PCI Express expansion slot 3
32	Reserved
33	PCI Express expansion slot 5*
34	PCI Express expansion slot 6*
35	Rear fan connector
36	PCI Express expansion slot 7*
37	Reserved

* x8 PCI Express cards are supported, but will run at x1 speeds.

System maintenance switch

Position	Default	Function
S1 Off		Off = iLO 2 security is enabled On = iLO 2 security is disabled
S2 Off		Off = System configuration can be changed On = System configuration is locked
S3 Off		Reserved
S4 Off		Reserved
S5 Off		Off = No function On = Clears power-on password and administrator password
S6	Off	Off = Normal On = ROM treats system configuration as invalid

Position	Default	Function
S7 Off		Reserved
S8 Off		Reserved

When the system maintenance switch position 6 is set to the On position, the system is prepared to erase all system configuration settings from both CMOS and NVRAM.

 **CAUTION:** Clearing CMOS and/or NVRAM deletes configuration information. Be sure to properly configure the server or data loss could occur.

For information on emergency ROM backup recovery, refer to ROMPaq disaster recovery (on page 62).

NMI functionality

An NMI crash dump enables administrators to create crash dump files when a system is hung and not responding to traditional debug mechanisms.

Crash dump log analysis is an essential part of diagnosing reliability problems, such as hangs in operating systems, device drivers, and applications. Many crashes freeze a system, and the only available action for administrators is to cycle the system power. Resetting the system erases any information that could support problem analysis, but the NMI feature preserves that information by performing a memory dump before a hard reset.

To force the OS to invoke the NMI handler and generate a crash dump log, the administrator can do any of the following:

- Short the NMI jumper pins
- Press the NMI switch
- Use the iLO Virtual NMI feature

For additional information, see the whitepaper on the HP website (<http://h20000.www2.hp.com/bc/docs/support/SupportManual/c00797875/c00797875.pdf>).

System board LEDs

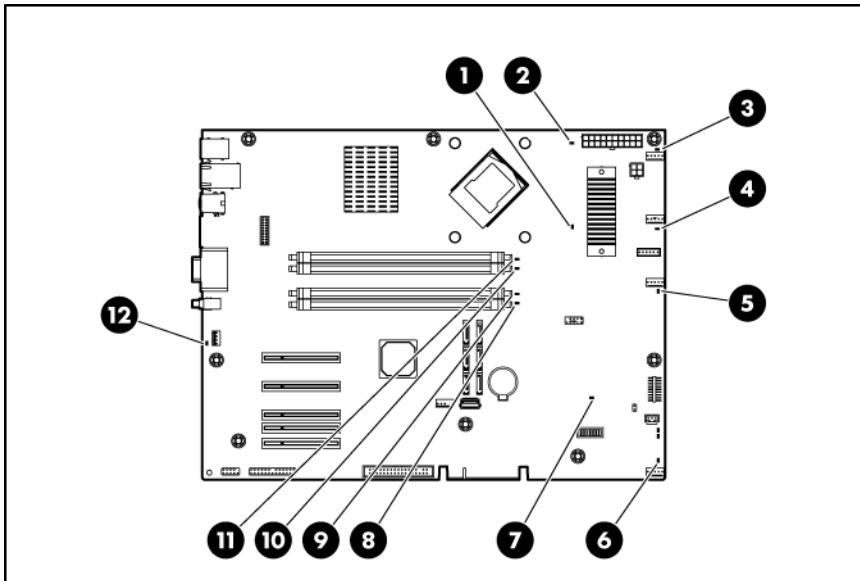

Item	LED description	Status
1	Processor failure	Amber = A multibit error has occurred. Off = Normal
2	PPM failure	Amber = PPM has failed. Off = Normal
3	Processor heatsink fan failure	Amber = Processor heatsink fan has failed or is missing. Off = Normal
4	Reserved	—
5	Reserved	—
6	PCI fan failure	Amber = PCI fan has failed or is missing. Off = Normal
7	Overtemperature	Amber = System has reached a cautionary or critical temperature level. Off = Normal
8	DIMM 4 failure	Amber = DIMM has failed or is missing. Off = Normal
9	DIMM 3 failure	Amber = DIMM has failed or is missing. Off = Normal
10	DIMM 2 failure	Amber = DIMM has failed or is missing. Off = Normal
11	DIMM 1 failure	Amber = DIMM has failed or is missing. Off = Normal
12	Rear fan failure	Amber = Rear fan has failed or is missing. Off = Normal

System LEDs and internal health LED combinations

When the internal health LED on the front panel illuminates either amber or red, the server is experiencing a health event. Combinations of illuminated system LEDs and the internal health LED indicate system status.

NOTE: The system management driver must be installed for the internal system health LED to provide pre-failure and warranty conditions.

The front panel health LEDs indicate only the current hardware status. In some situations, HP SIM may report server status differently than the health LEDs because the software tracks more system attributes.

System LED and color	Internal health LED color	Status
Processor failure (Amber)	Red	One or more of the following conditions may exist: <ul style="list-style-type: none">• Processor has failed.• Processor is not installed in the socket.• ROM detected a failed processor during POST.
	Amber	Processor is in a pre-failure condition.
PPM failure (Amber)	Red	PPM has failed.
DIMM failure, slot X (Amber)	Red	<ul style="list-style-type: none">• DIMM in slot X has failed.• DIMM has experienced a multi-bit error.
	Amber	<ul style="list-style-type: none">• DIMM in slot X has reached single-bit correctable error threshold.• DIMM in slot X is in a pre-failure condition.
DIMM failure (all slots, Amber)	Red	<ul style="list-style-type: none">• No valid or usable memory is installed in the system.• The banks are not populated in the correct order.
Overtemperature (Amber)	Red	System temperature has exceeded OS cautionary level or critical hardware level.
Fan failure (Amber)	Red	A required fan has failed.

PCI-X extender board components

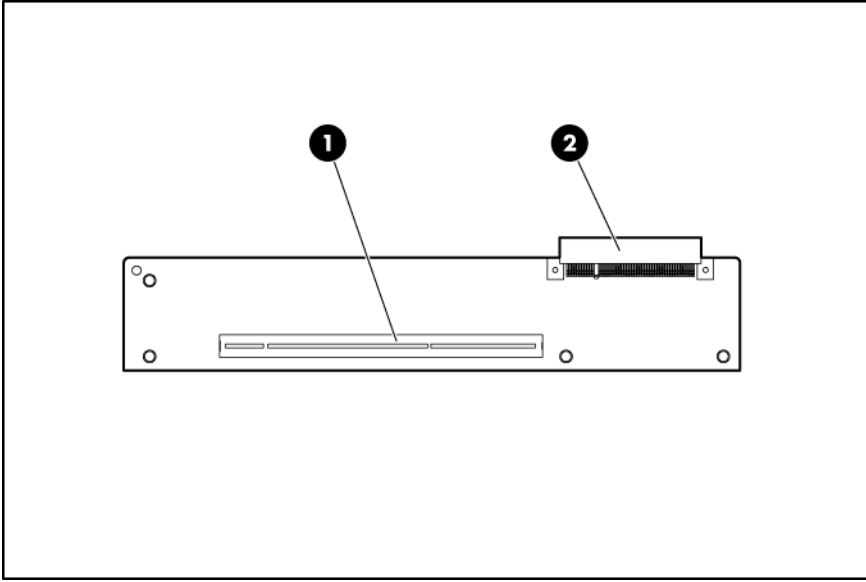

Item	Description
1	PCI-X expansion slot 1
2	System board connector

Fan locations

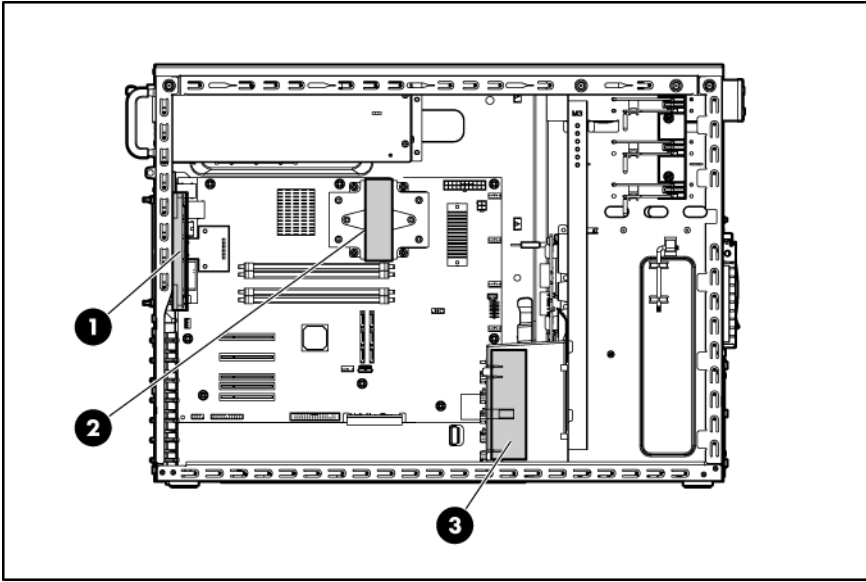

Item	Description
1	Rear fan
2	Processor fan
3	PCI fan (optional)

Specifications

Environmental specifications

Specification	Value
Temperature range*	
Operating 10	°C to 35°C (50°F to 95°F)
Shipping -1	0°C to 60°C (14°F to 140°F)
Maximum wet bulb temperature	28°C (82.4°F)
Relative humidity (noncondensing)**	
Operating 20%	to 80%
Non-operating 20%	to 90%

* All temperature ratings shown are for sea level. An altitude derating of 1°C per 300 m (1.8°F per 1,000 ft) to 3048 m (10,000 ft) is applicable. No direct sunlight allowed.

** Storage maximum humidity of 95% is based on a maximum temperature of 45°C (113°F). Altitude maximum for storage corresponds to a pressure minimum of 70 KPa.

Server specifications

Specification	Value
Dimension	
Height	43.2 cm (17.0 in)
Depth (without bezel)	58.0 cm (22.8 in)
Depth (with bezel)	61.0 cm (24.0 in)
Width	20.0 cm (7.9 in)
Weight (no drives installed)	15.0 kg (33.1 lb)
Input requirement	
Rated input voltage	100 VAC to 240 VAC *
Rated input frequency	47 Hz to 63 Hz
Rated input current	8 A (100 V) to 4 A (200 V)
Rated input power	1000 W
BTUs per hour	2730
Power supply output	
Rated steady-state power	3.3 V/5 V 110 W 12 V CPU 300 W

Specification	Value
Maximum peak power	410 W (non-redundant non-hot-plug) 430 W (redundant hot-plug)

* 100 to 127 VAC is required for 8 A; 200 to 240 VAC is required for 4 A.

Acronyms and abbreviations

CMOS

complementary metal-oxide semiconductor

CSR

Customer Self Repair

DDR2

double data rate-2

HP SIM

HP Systems Insight Manager

NMI

non-maskable interrupt

PCI

peripheral component interface

PCI Express

Peripheral Component Interconnect Express

PCI-X

peripheral component interconnect extended

POST

Power-On Self Test

PPM

processor power module

RAID

redundant array of inexpensive (or independent) disks

RBSU

ROM-Based Setup Utility

SAS

serial attached SCSI

SATA

serial ATA

SCSI

small computer system interface

UID

unit identification

UPS

uninterruptible power system

USB

universal serial bus

Index

A

access panel 16, 28
additional information 61
air baffle 39

B

battery 51, 70
bezel 16, 27
bezel blank 28
bezel key 19
bezel lock 27, 63
bezel, front 16, 28
bezel, removing 27
bezel, tower 27
blanks 16, 28, 29, 30
blue screen event 70
buttons 63, 64

C

cables 31, 32, 59, 60
cabling 59, 60
component identification 63, 70
components 16, 19, 63, 66
connectors 63
controller 19
crash dump analysis 70
CSR (customer self repair) 5
customer self repair (CSR) 5, 16, 19

D

device numbers 65
diagnostic tools 61
diagnostics utility 61
DIMM slot LEDs 71, 72
DIMMs 19, 42, 68
disaster recovery 62
Disaster Recovery, ROMPaq 62
diskette drive 19, 33, 34
diskette drive connectors 68
drive LEDs 65
DVD-ROM drive 19, 34, 63

E

electrostatic discharge 24
environmental specifications 74
expansion boards 50
expansion slots 68, 73

F

fan connectors 68
fan holder 16, 38
fan LED 72
fans 19, 38, 39, 73
fans, replacing 39
features 63
feet, server 16, 58
front bezel 16, 27
front panel buttons 64
front panel components 63
front panel LEDs 64
front panel/LED board connector 68
front temperature sensor cable 19
front USB cable 19, 33
front USB connectors 33, 68
full-height media drive 19, 35
full-height tape drive 19, 35

H

half-height media drive 19
hard drive backplane 19, 37
hard drive bays 63
hard drive blanks 16, 30
hard drive cable 19
hard drive cable connector 68
hard drive cage 19, 37
hard drive LEDs 65
hard drive, replacing 30
hard drives 19, 30, 37
health LEDs 64, 70, 72
heatsink 19, 43
HP Insight Diagnostics 61
HP Insight Diagnostics survey functionality 61

I

iLO (Integrated Lights-Out) 69
IML (Integrated Management Log) 62
Insight Diagnostics 61
Integrated Management Log (IML) 62
internal health LED 72
internal USB connector 68

K

keyboard connector 66

L

LED, DIMM slot 71, 72
LED, drive activity 64
LED, fan 71, 72
LED, health 64, 72
LED, internal health 64, 72
LED, link/port activity 64, 67
LED, power supply signal 67
LED, processor 71, 72
LED, system power 26, 64
LEDs, front panel 64
LEDs, hard drive 65
LEDs, NIC 67
LEDs, power supply 67
LEDs, PPM failure 71, 72
LEDs, processor failure 71, 72
LEDs, rear panel 67
LEDs, SAS hard drive 65
LEDs, system board 71
LEDs, troubleshooting 65, 71, 72

M

management tools 61
mechanical components 16
media bay blank 29, 63
memory 19, 42
memory slot LEDs 71
mouse connector 66

N

network connector LEDs 67
NIC LEDs 64, 67
NMI switch 68, 70

O

optical device 34

optical drive cable 19
optical drive connector 68
overtemperature LED 71, 72

P

parallel connector 68
part numbers 16, 19
PCI card guide 16, 39
PCI fan 39
PCI slots 71
PCI-X extender board 19, 50
PCI-X extender board components 73
PCI-X extender board connector 68
power button/LED cable 19, 31
power connectors, external 66
power connectors, internal 68
power cord connector 66
Power On/Standby button 26, 63
power supplies 19, 40, 41, 66
power supplies, removing 40, 41
power supply backplane 41
power supply cage assembly 19, 41
powering down 26
PPM failure LEDs 71, 72
preparation procedures 26
processor failure LEDs 69, 72
processor power connector 68
processors 19

R

rear fan 38
rear panel components 66
rear panel connectors 66
rear panel LEDs 67
redundant power supply cable connector 68
required tools 24
RJ-45 network connector LEDs 67
ROMPaq Disaster Recovery 62

S

safety considerations 24
safety information 24
SAS cabling 60
SAS device numbers 65
SAS hard drive cabling 60
SAS hard drive LEDs 65
SATA cabling 60
SATA drives 65
SATA hard drive LEDs 65

- SATA optical drive 34
- serial connector 66, 68
- serial number 52
- server feet 16, 58
- server specifications 74
- server, front panel LEDs 64
- server, rear panel LEDs 67
- server, rear panel components 66
- spare part numbers 16, 19
- specifications, environmental 74
- specifications, server 74
- static electricity 24
- switches 69, 70
- system air baffle 16, 39
- system battery 19, 68
- system board 52, 68
- system board battery 51
- system board components 68
- system board LEDs 71
- system components 19
- system maintenance switch 68, 69, 70
- system power connector 68
- system power LED 26

T

- T-10/T-15 Torx screwdriver 19, 24
- tape drives 35, 36
- temperature ranges (environmental) 74
- temperature sensor 32
- tools 16, 24, 61
- tower bezel, removing 27
- troubleshooting 61
- troubleshooting resources 61

U

- USB connectors 33, 63, 66
- USB devices 33
- USB flash device 19, 36
- USB tape drive cable connector 68
- utilities 61

V

- video connector 66

W

- warnings 24, 25