

# HP ProLiant ML350 Generation 3 Server Maintenance and Service Guide



March 2004 (Third Edition)  
Part Number 316336-003

© Copyright 2003, 2004 Hewlett-Packard Development Company, L.P.

Microsoft, Windows, and Windows NT are U.S. registered trademarks of Microsoft Corporation.

Intel is a registered trademark of Intel Corporation in the U.S. and other countries and is used under license.

Java is a U.S. trademark of Sun Microsystems, Inc.

Hewlett-Packard Company shall not be liable for technical or editorial errors or omissions contained herein. The information in this document is provided "as is" without warranty of any kind and is subject to change without notice. The warranties for HP products are set forth in the express limited warranty statements accompanying such products. Nothing herein should be construed as constituting an additional warranty.

HP ProLiant ML350 Generation 3 Server Maintenance and Service Guide

March 2004 (Third Edition)  
Part Number 316336-003

---

# Contents

## About This Guide

Audience Assumptions .....	vii
Technician Notes .....	vii
Where to Go for Additional Help .....	ix
Integrated Management Log .....	ix
Telephone Numbers .....	ix

## Chapter 1

### Illustrated Parts Catalog

Mechanical Parts Exploded View .....	1-2
Mechanical Spare Parts List .....	1-3
System Components Exploded View .....	1-4
System Components Spare Parts List .....	1-5

## Chapter 2

### Removal and Replacement Procedures

Electrostatic Discharge Information .....	2-2
Symbols on Equipment .....	2-3
Preparation Procedures .....	2-4
Non-Hot-Pluggable Device .....	2-4
Powering Down the Server .....	2-4
Rack Stability Warning .....	2-5
Bezel Door (Tower Model Only) .....	2-6
Access Panel .....	2-7
Bezel (Rack Model Only) .....	2-8
Removable Media Device Blank .....	2-11
Cable Routing Diagrams .....	2-12
Diskette Drive Signal Cable .....	2-12
IDE CD-ROM Drive Signal Cable .....	2-13
Removable Media Device Cable .....	2-13
SCSI Point-to-Point Cable .....	2-14
Air Baffle .....	2-15
System Fan Modules .....	2-16
Drive Bay Configuration .....	2-19
Hot-Plug Hard Drive Blank .....	2-20
Hot-Plug Hard Drive .....	2-21
Hot-Plug Hard Drive Cage .....	2-22
Removable Media Device .....	2-24
Expansion Slots .....	2-27

Expansion Board ..... 2-28

Memory Module Guidelines ..... 2-30

Memory Modules ..... 2-31

Processors and Processor Power Modules ..... 2-32

    Processor ..... 2-33

    Processor Power Module ..... 2-36

System Board ..... 2-37

Re-entering the Server Serial Number ..... 2-38

System Battery ..... 2-39

    System Board Battery ..... 2-39

Power Supply ..... 2-41

Power Supply Backplane Board ..... 2-42

Feet (Tower Model Only) ..... 2-43

**Chapter 3**

**Diagnostic Tools**

Diagnostic Tools Utility Overview ..... 3-1

For More Information ..... 3-4

**Chapter 4**

**Connectors, Switches, and LEDs**

Connectors and Components ..... 4-2

    Rear Panel Components ..... 4-2

    System Board Components ..... 4-3

Switches ..... 4-4

    System Configuration Switch Settings ..... 4-4

    Resetting System Configuration Settings ..... 4-6

LEDs ..... 4-7

    Power Button, System Status LEDs, and Unit Identification Button ..... 4-8

System Board LEDs ..... 4-11

    Hot-Plug Hard Drive LEDs ..... 4-13

    Network Interface Controller LEDs ..... 4-16

**Chapter 5**

**Physical and Operating Specifications**

System Unit ..... 5-2

Rack Server System Unit ..... 5-3

Memory ..... 5-4

1.44-MB Diskette Drive ..... 5-4

IDE CD-ROM Drive ..... 5-5

Wide Ultra3 SCSI Hot-Plug Hard Drives ..... 5-6

Integrated NC7760 Gigabit Server Auto-switching NIC ..... 5-6

Integrated Dual Channel Wide Ultra3 SCSI Adapter..... 5-7

Remote Insight Lights-Out Edition II Option Board..... 5-8

**Index**



---

## About This Guide

This maintenance and service guide can be used for reference when servicing HP ProLiant ML350 Generation 3 servers.



**WARNING:** To reduce the risk of personal injury from electric shock and hazardous energy levels, only authorized service technicians should attempt to repair this equipment. Improper repairs can create conditions that are hazardous.

---

## Audience Assumptions

This guide is for service technicians. HP assumes you are qualified in the servicing of computer equipment and trained in recognizing hazard in products with hazardous energy levels and are familiar with weight and stability precautions for rack installations.

## Technician Notes



**WARNING:** Only authorized technicians trained by HP should attempt to repair this equipment. All troubleshooting and repair procedures are detailed to allow only subassembly/module-level repair. Because of the complexity of the individual boards and subassemblies, no one should attempt to make repairs at the component level or to make modifications to any printed wiring board. Improper repairs can create a safety hazard.

---



**WARNING:** To reduce the risk of personal injury from electric shock and hazardous energy levels, do not exceed the level of repairs specified in these procedures. Because of the complexity of the individual boards and subassemblies, do not attempt to make repairs at the component level or to make modifications to any printed wiring board. Improper repairs can create conditions that are hazardous.

---



**WARNING:** To reduce the risk of electric shock or damage to the equipment:

- **Disconnect power from the system by unplugging all power cords from the power supplies.**
  - **Do not disable the power cord grounding plug. The grounding plug is an important safety feature.**
  - **Plug the power cord into a grounded (earthed) electrical outlet that is easily accessible at all times.**
- 



**CAUTION:** To properly ventilate the system, you must provide at least 7.6 cm (3.0 in.) of clearance at the front and back of the server.

---



**CAUTION:** The computer is designed to be electrically grounded (earthed). To ensure proper operation, plug the AC power cord into a properly grounded AC outlet only.

---

**NOTE:** Any indications of component replacement or printed wiring board modifications may void any warranty.



## Where to Go for Additional Help

In addition to this guide, the following information sources are available:

- User documentation
- *Service Quick Reference Guide*
- Service training guides
- Service advisories and bulletins
- QuickFind information services
- Insight Manager software

## Integrated Management Log

The server includes an integrated, nonvolatile management log that contains fault and management information. The contents of the Integrated Management Log (IML) can be viewed with Insight Manager.

## Telephone Numbers

For the name of your nearest HP authorized reseller:

- In the United States, call 1-800-345-1518.
- In Canada, call 1-800-263-5868.

For HP technical support:

- In the United States and Canada, call 1-800-652-6672.
- Outside the United States and Canada, refer to [www.hp.com](http://www.hp.com)

---

## Illustrated Parts Catalog

This chapter provides the illustrated parts breakdown and spare parts lists for the HP ProLiant ML350 Generation 3 server. Refer to Table 1-1, and Table 1-2 for the names of referenced spare parts.

# Mechanical Parts Exploded View

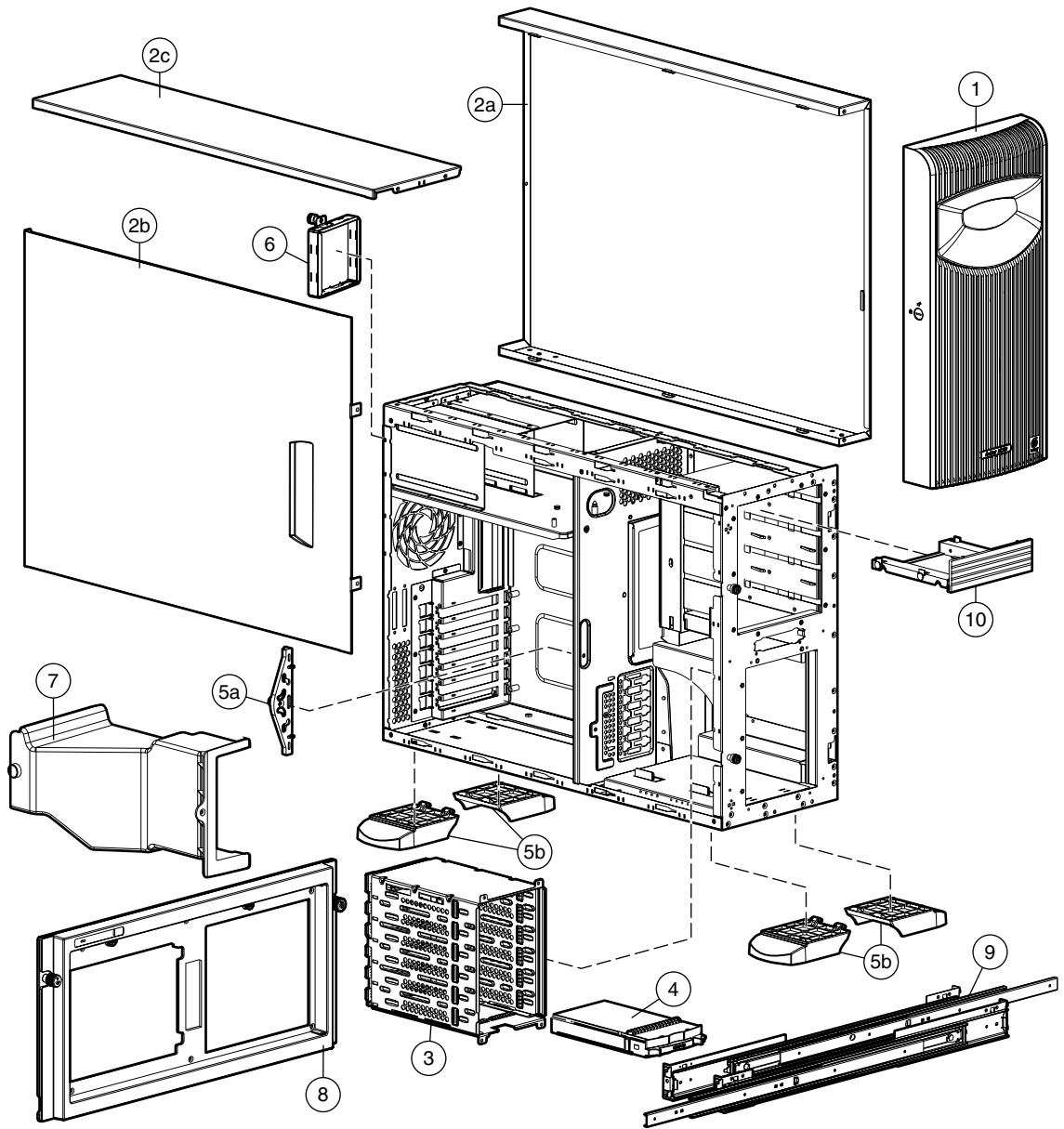

Figure 1-1: Mechanical parts exploded view

## Mechanical Spare Parts List

**Table 1-1: Mechanical Spare Parts List**

Item	Description	Spare Part Number
<b>Chassis</b>		
1	Bezel door (tower model only)	322315-001
2	Cover kit	216104-001
	a) Hood panel (tower model only)	
	b) Access panel	
	c) Top panel	
3	Hot-plug hard drive cage	262171-001
4	Hot-plug hard drive blank	122759-001
5	Miscellaneous plastics kit	250843-001
	a) Expansion board retainer	
	b) Feet (4) (tower model only)	
	c) Expansion board guide*	
	d) Retainer clips*	
6	Power supply blank	249923-001
7	Air baffle	289549-001
8	Front faceplate and bezel (rack model only)	322316-001
9	Rack-mounting hardware kit with rails and cable management arm	292230-001
10	Removable media device blank	231212-001
*Not shown		

## System Components Exploded View

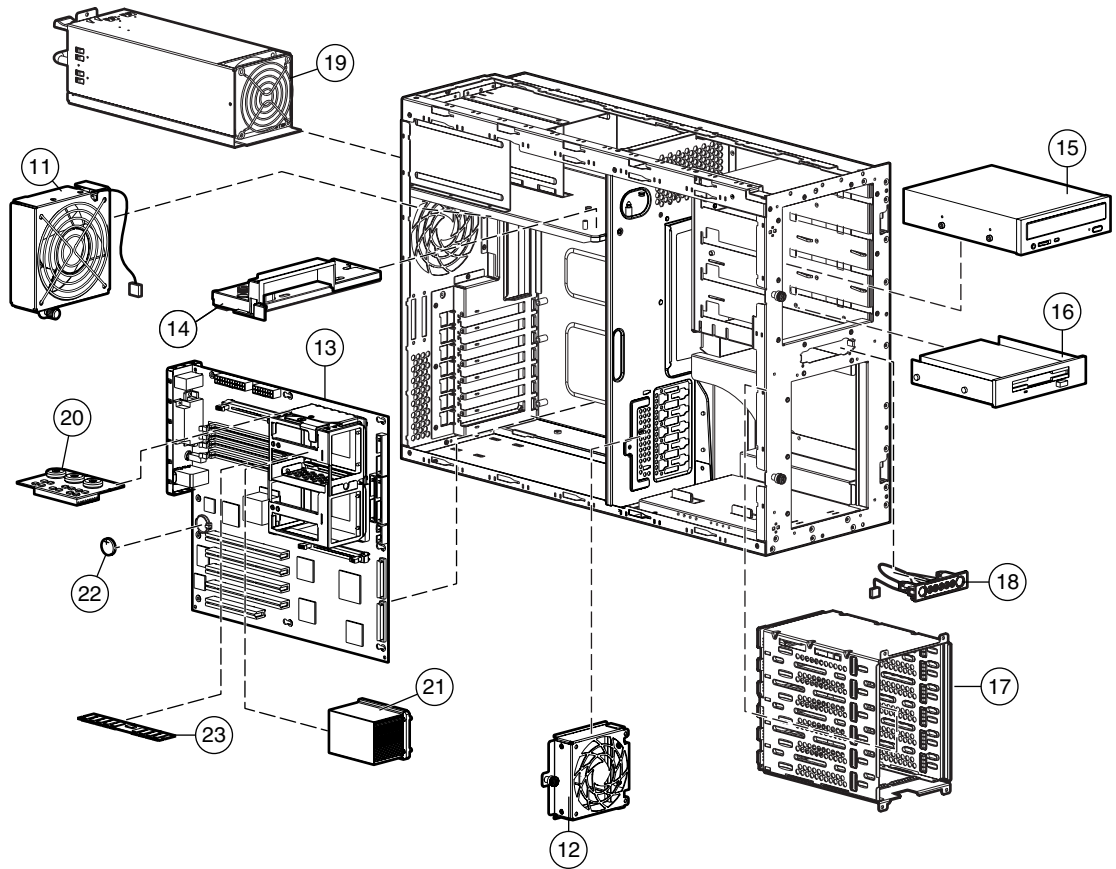

Figure 1-2: System components exploded view

## System Components Spare Parts List

**Table 1-2: System Components Spare Parts List**

Item	Description	Spare Part Number
11	CPU fan module, 120 mm	301017-001
12	I/O fan module, 92 mm	289562-001
<b>Boards</b>		
13	System board 400 MHz	292234-001
	System board 533 MHz*	322318-001
14	Power supply backplane board with cover	292235-001
<b>Mass storage devices</b>		
15	IDE CD-ROM drive (48X)	288894-001
16	Diskette drive	233409-001
17	Hot-plug hard drive cage	262171-001
<b>Power</b>		
18	Power switch assembly	292236-001
19	500-W power supply with power factor correction	292237-001
20	Processor Power Module (PPM)	290560-001
<b>Options</b>		
21	Processor with Heatsink	
	a) Intel® Xeon 2.0-GHz/400-MHz	301018-001
	b) Intel Xeon 2.2-GHz/400-MHz*	301019-001
	c) Intel Xeon 2.4-GHz/400-MHz*	290558-001
	d) Intel Xeon 2.8-GHz/533-MHz* **	322560-001
	e) Intel Xeon 2.8-GHz/1-MB* **	359650-001
	f) Intel Xeon 3.06-GHz/533-MHz* **	314669-001
22	CR2032 lithium battery for system board	234556-001
23	Memory	
	a) 128-MB PC2100 DDR ECC Registered DIMM	301691-001
	b) 256-MB PC2100 DDR ECC Registered DIMM*	300699-001
	c) 512-MB PC2100 DDR ECC Registered DIMM*	300700-001
	d) 1-GB PC2100 DDR ECC Registered DIMM*	300701-001
	e) 2-GB PC2100 DDR ECC Registered DIMM*	300702-001

\*Not shown

\*\* Processors with 533-MHz front side bus can only be used on the 533 system board.

*continued*

**Table 1-2: System Components Spare Parts List** *continued*

Item	Description	Spare Part Number
<b>Miscellaneous</b>		
24	Enhanced keyboard (carbon)*	311059-001
25	Mouse (carbon)*	311060-001
26	Signal cable kit*	163353-001
	a) IDE ribbon cable assembly	
	b) Diskette drive cable assembly	
	c) Removable media device SCSI cable	
27	SCSI Point-to-Point cable*	292232-001
28	Return kit (tower model only)*	249929-001
29	Return kit (rack model only)*	250189-001
30	Country kit for 400-MHz models*	303713-001
31	Country kit for 533-MHz model*	322320-001
32	Tower-to-rack conversion kit*	292231-001
33	Hard drive blank tray*	319602-001
34	Diskette drive*	322319-001
35	AC Power cord 12 in, 120 V*	292231-001

\*Not shown

---

## Removal and Replacement Procedures

This chapter provides subassembly/module-level removal and replacement procedures for the HP ProLiant ML350 Generation 3 server. After completing any removal or replacement procedure, run the diagnostics program to verify that all components operate properly.

To service the server, a T-15 Torx screwdriver may be needed.



## Electrostatic Discharge Information

An electrostatic discharge (ESD) can damage static-sensitive devices or microcircuitry. Proper packaging and grounding techniques are necessary precautions to prevent damage. To prevent electrostatic damage, observe the following precautions:

- Transport products in static-safe containers such as conductive tubes, bags, or boxes.
- Keep electrostatic-sensitive parts in their containers until they arrive at static-free stations.
- Cover workstations with approved static-dissipating material. Use a wrist strap connected to the work surface, and properly grounded (earthed) tools and equipment.
- Keep work area free of nonconductive materials, such as ordinary plastic assembly aids and foam packing.
- Make sure that you are always properly grounded (earthed) when touching a static-sensitive component or assembly.
- Avoid touching pins, leads, or circuitry.
- Always place drives with the Printed Circuit Board (PCB) assembly-side down.
- Use conductive field service tools.

## Symbols on Equipment

These symbols may be located on equipment in areas where hazardous conditions may exist.



**WARNING:** This symbol, in conjunction with any of the following symbols, indicates the presence of a potential hazard. The potential for injury exists if warnings are not observed. Consult your documentation for specific details.



This symbol indicates the presence of hazardous energy circuits or electric shock hazards. Refer all servicing to qualified personnel.

**WARNING:** To reduce the risk of injury from electric shock hazards, do not open this enclosure. Refer all maintenance, upgrades, and servicing to qualified personnel.



This symbol indicates the presence of electric shock hazards. The area contains no user or field serviceable parts. Do not open for any reason.

**WARNING:** To reduce the risk of injury from electric shock hazards, do not open this enclosure



This symbol on an RJ-45 receptacle indicates a network interface connection.

**WARNING:** To reduce the risk of electric shock, fire, or damage to the equipment, do not plug telephone or telecommunications connectors into this receptacle.



This symbol indicates the presence of a hot surface or hot component. If this surface is contacted, the potential for injury exists.

**WARNING:** To reduce the risk of injury from a hot component, allow the surface to cool before touching.



These symbols, on power supplies or systems, indicate that the equipment is supplied by multiple sources of power.

**WARNING:** To reduce the risk of injury from electric shock, remove all power cords to completely disconnect power from the system.



This symbol indicates that the component exceeds the recommended weight for one individual to handle safely.

Weight in kg  
Weight in lb

**WARNING:** To reduce the risk of personal injury or damage to the equipment, observe local occupational health and safety requirements and guidelines for manual material handling.

## Preparation Procedures



**WARNING:** Only authorized technicians trained by HP should attempt to repair this equipment. Because of the complexity of the individual boards and subassemblies, no one should attempt to make repairs at the component level or to make modifications to any printed wiring board. Improper repairs can create a safety hazard.

---



**CAUTION:** Electrostatic discharge (ESD) can damage electronic components. Be sure that you are properly grounded (earthed) before beginning any installation procedure. Refer to “Electrostatic Discharge Information” earlier in this chapter for more information.

---

Before removing any serviceable parts, determine whether the part is hot-pluggable or non-hot-pluggable.

## Non-Hot-Pluggable Device

If the device is non-hot-pluggable, the server must be powered down. Non-hot-pluggable devices in the server include the processor, all boards, memory modules, fans, PCI option cards and drive cages.

## Powering Down the Server

The server does not completely power down when the front panel power button is pressed. The button toggles between On and Standby. The standby position removes power from most electronics and the drives, but some internal circuitry remains active. To completely remove all power from the system, disconnect all power cords from the server.



**WARNING:** To reduce the risk of injury from electric shock, disconnect all power cords to completely remove power from the system.

---



**WARNING:** To reduce the risk of personal injury from hot surfaces, allow the internal system components to cool before touching them.

---



**CAUTION:** Protect the server from power fluctuations and temporary interruptions with a regulating uninterruptible power supply (UPS). This device protects the hardware from damage caused by power surges and voltage spikes, and keeps the system in operation during a power failure.

---



**CAUTION:** The server must always be operated with system unit covers on. Proper cooling is not achieved when the system unit covers are removed.

---

To power down the server:

1. Press the power button to toggle to Standby. This places the server in standby mode, disabling the main power supply output and providing auxiliary power to the server. Standby does not completely disable or remove power from the system.
2. Be sure that the system LED closest to the right on the front panel is amber and that the fan noise has stopped.
3. Disconnect the AC power cord from the AC outlet, and then from the server.
4. Disconnect all external peripheral devices from the server.

## Rack Stability Warning

For stability and safety, properly positioning the server is critical.



**WARNING:** To reduce the risk of personal injury or damage to the equipment, be sure that:

- The leveling jacks are extended to the floor.
  - The full weight of the rack rests on the leveling jacks.
  - The stabilizing feet are connected to the rack if it is a single-rack installation.
  - The racks are coupled together in multiple-rack installations.
  - Only one component is extended at a time. A rack may become unstable if more than one component is extended for any reason.
-

## Bezel Door (Tower Model Only)

To remove the bezel door:

1. Complete the preparation procedures. Refer to “Preparation Procedures” earlier in this chapter.
2. If the keylock is locked, unlock the bezel door using the included key (1).
3. Open the bezel door fully to the right (2).
4. Lift the bezel door and then pull it away from the chassis (3).

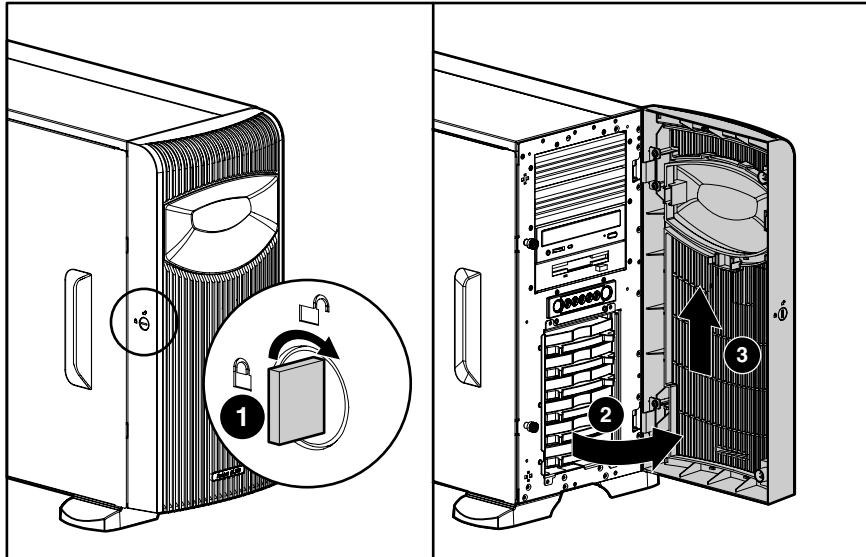

**Figure 2-1: Removing the bezel door (tower model only)**

To replace the bezel door, reverse steps 3 and 4.

## Access Panel

To remove the access panel:

1. Complete the preparation procedures. Refer to “Preparation Procedures” earlier in this chapter.
2. Open the bezel door fully to the right. Refer to “Bezel Door (Tower Model Only)” earlier in this chapter.
3. Loosen the two thumbscrews located on the left of the front chassis (1).
4. Slide the access panel back about 1.5 cm (0.5 inch), then lift and remove the panel (2).

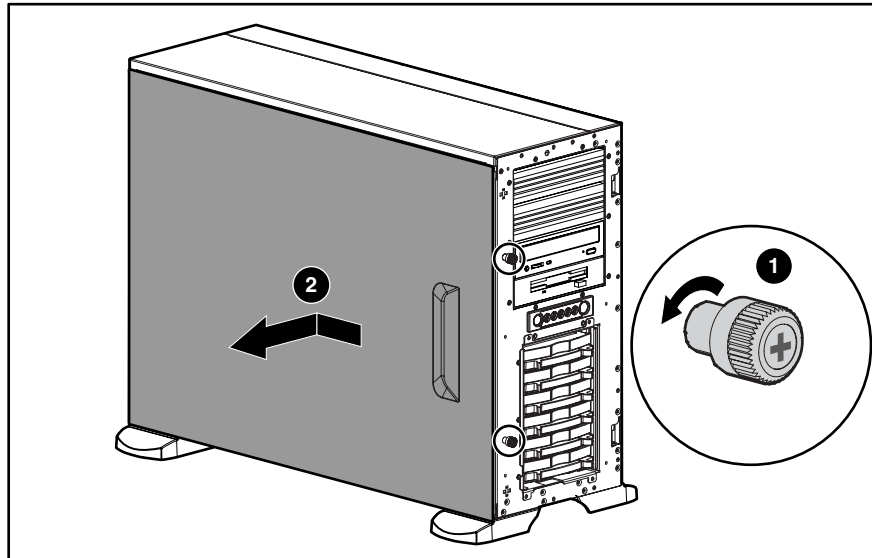

**Figure 2-2: Removing the access panel**

To replace the access panel, reverse steps 2 through 4.

## Bezel (Rack Model Only)

To remove the bezel:

1. Complete the preparation procedures. Refer to “Preparation Procedures” earlier in this chapter.
2. Loosen the thumbscrews holding the chassis in the rack (1).
3. Fully extend the chassis from the rack.

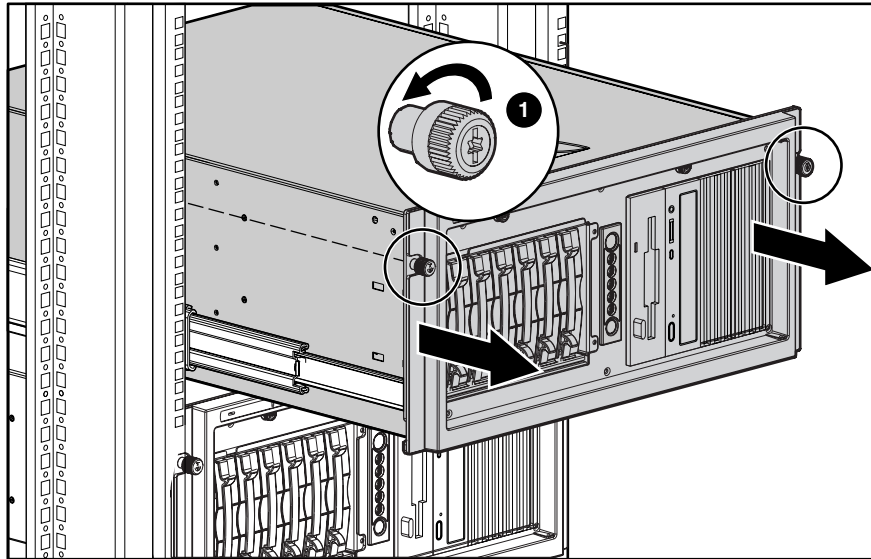

**Figure 2-3: Loosen the thumbscrews holding the chassis and fully extend the chassis from the rack**

4. Loosen the access panel thumbscrews (1).
5. Slide the access panel back about 1.5 cm (0.5 inch), then lift and remove the panel (2).

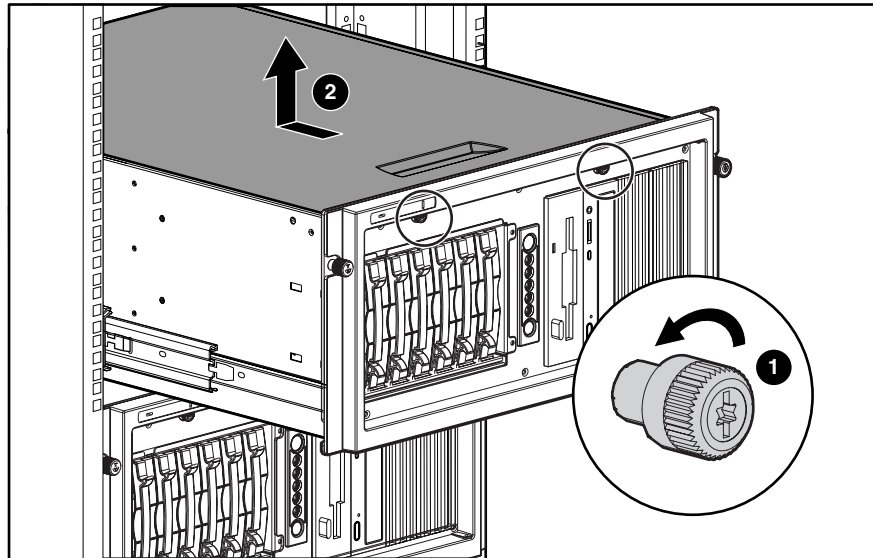

**Figure 2-4: Loosening the access panel thumbscrews**

6. Loosen the two thumbscrews securing the rack bezel to the chassis.

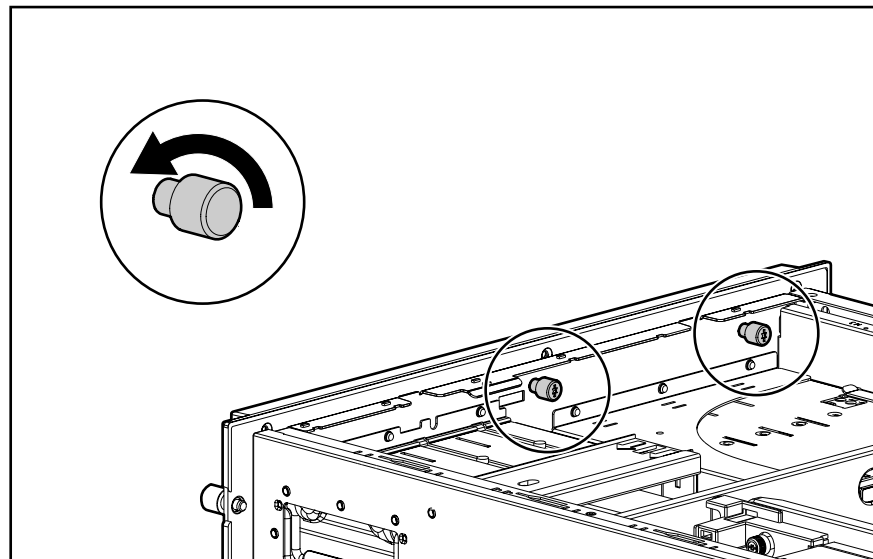

**Figure 2-5: Loosening the thumbscrews securing the rack bezel to the chassis**



7. Pull the bezel up and away from the chassis.

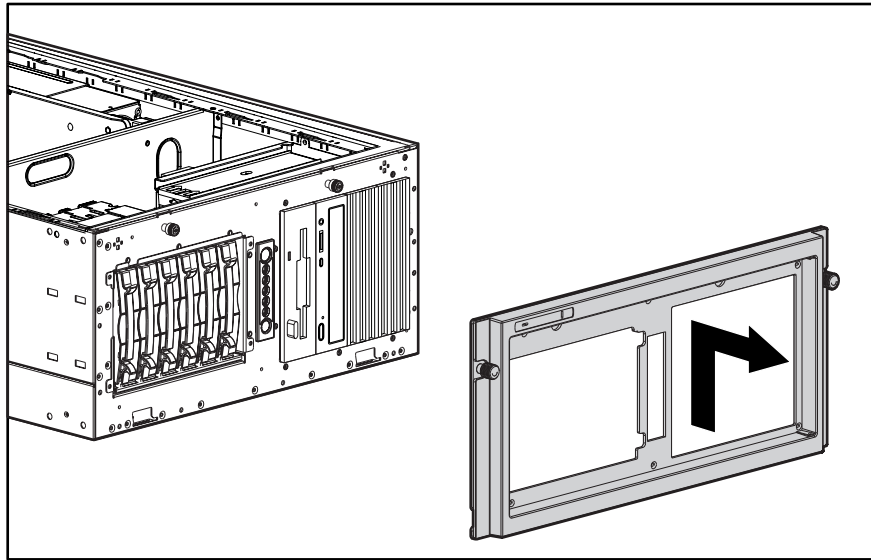

**Figure 2-6: Removing the bezel (rack model only)**

To replace the bezel, reverse steps 2 through 7.

## Removable Media Device Blank

**IMPORTANT:** To install a removable media device or a hard drive for the first time, the removable media device blank must be removed from an available removable media bay.

To remove a removable media device blank from the front chassis:

1. Complete the preparation procedures. Refer to “Preparation Procedures” earlier in this chapter.
2. Open the bezel door. Refer to “Bezel Door (Tower Model Only)” earlier in this chapter.
3. Remove the access panel. Refer to “Access Panel” earlier in this chapter.
4. Push up on the drivelock to release the device blanks (1).
5. Gently pull the appropriate blank completely out from the front of the chassis (2).

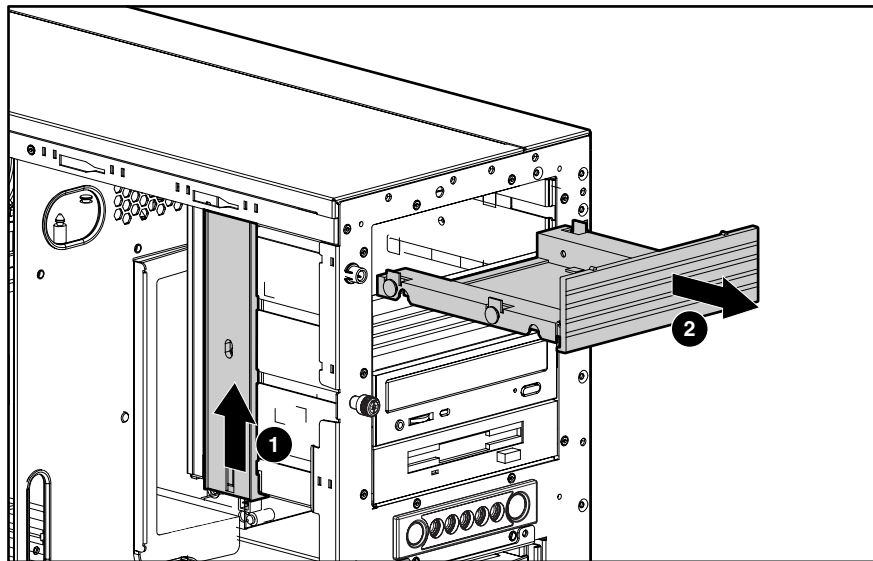

**Figure 2-7: Removing the media device blank**

To replace the media device blank, reverse steps 2 through 5.

## Cable Routing Diagrams

Figure 2-8 through Figure 2-11 show the cable routing for the server.



**CAUTION:** When routing cables, be sure that the cables are not in a position where they can be pinched or crimped.

---

### Diskette Drive Signal Cable

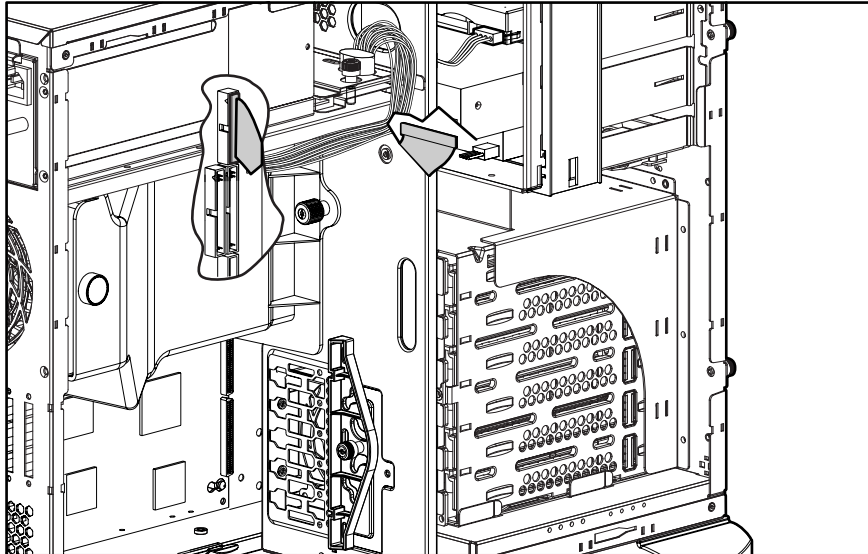

**Figure 2-8: Diskette drive signal cable routing**

### IDE CD-ROM Drive Signal Cable

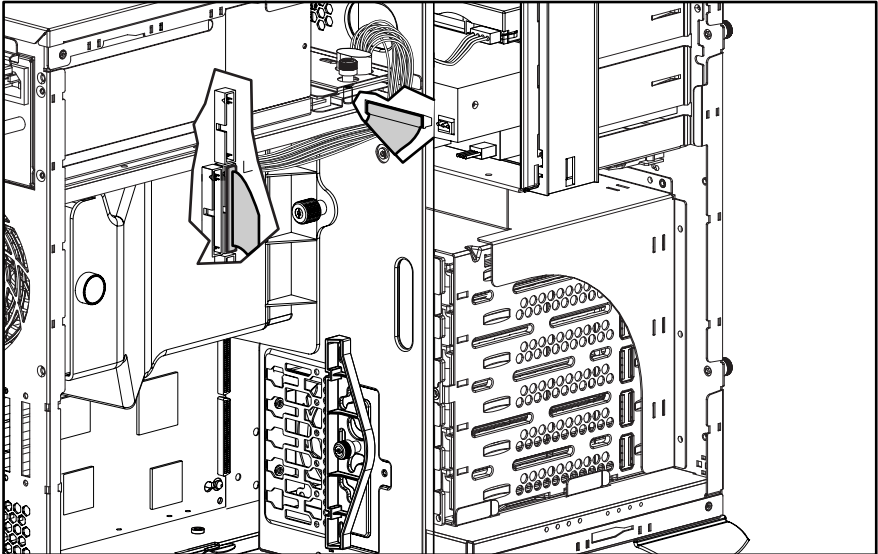

Figure 2-9: IDE CD-ROM drive signal cable routing

### Removable Media Device Cable

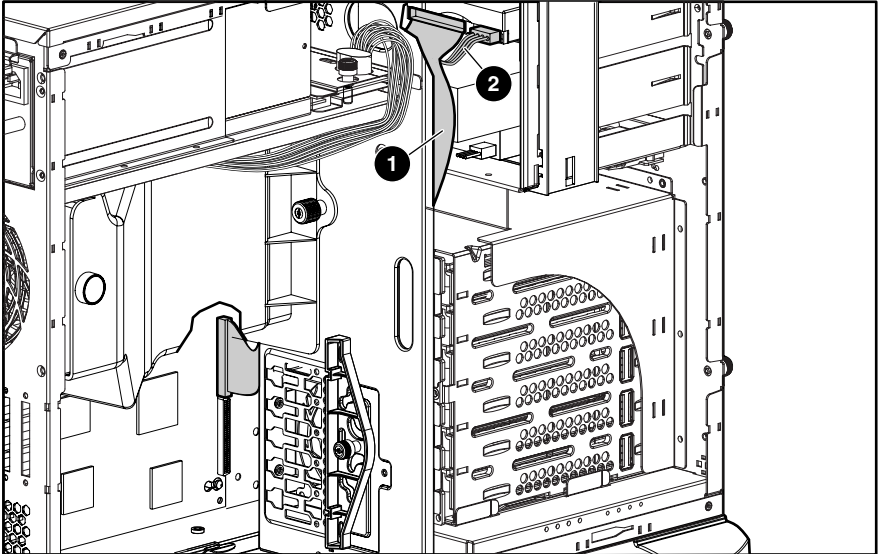
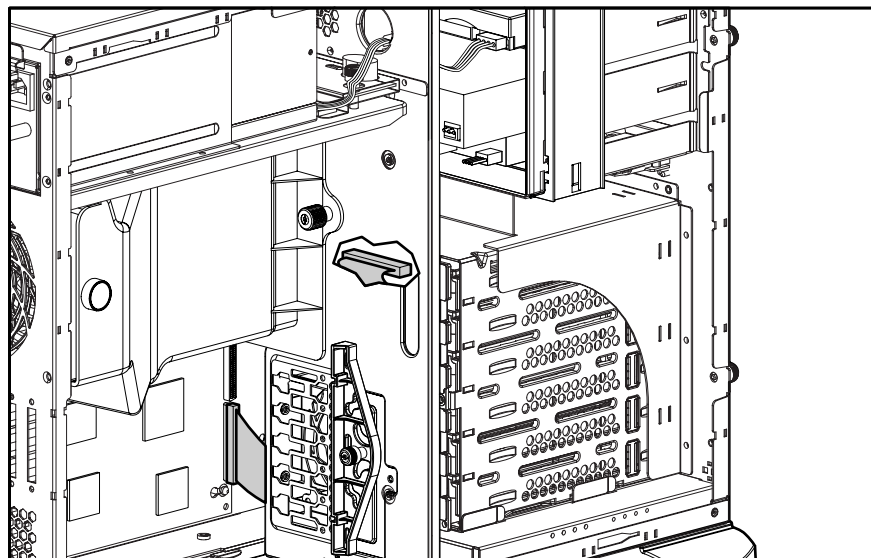

Figure 2-10: Removable media device cable routing

Table 2-1: Removable Media Device Cable Routing

Item	Description
1	Signal cable
2	Power cable

## SCSI Point-to-Point Cable

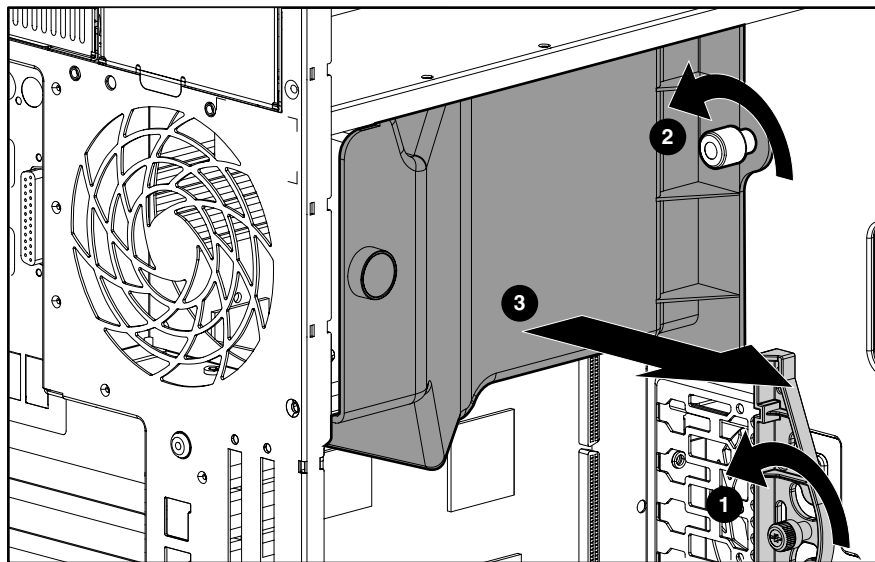

**Figure 2-11: SCSI LVD Point-to-Point cable routing**

## Air Baffle

To remove the air baffle:

1. Complete the preparation procedures. Refer to “Preparation Procedures” earlier in this chapter.
2. Open the bezel door. Refer to “Bezel Door (Tower Model Only)” earlier in this chapter.
3. Remove the access panel. Refer to “Access Panel” earlier in this chapter.
4. Loosen the thumbscrew (1) and remove the PCI card retainer.
5. Loosen the thumbscrew that secures the air baffle to the server chassis (2).
6. Lift the air baffle out of the server (3).



**Figure 2-12: Removing the air baffle**

To replace the air baffle, reverse steps 2 through 6.

## System Fan Modules

To remove the system CPU fan module:

1. Complete the preparation procedures. Refer to “Preparation Procedures” earlier in this chapter.
2. Open the bezel door. Refer to “Bezel Door (Tower Model Only)” earlier in this chapter.
3. Remove the access panel. Refer to “Access Panel” earlier in this chapter.
4. Remove the air baffle. Refer to “Air Baffle” earlier in this chapter.
5. Disconnect the system CPU fan cable (1) from the system board.

**NOTE:** I/O fan cable connection show for clarity (2).

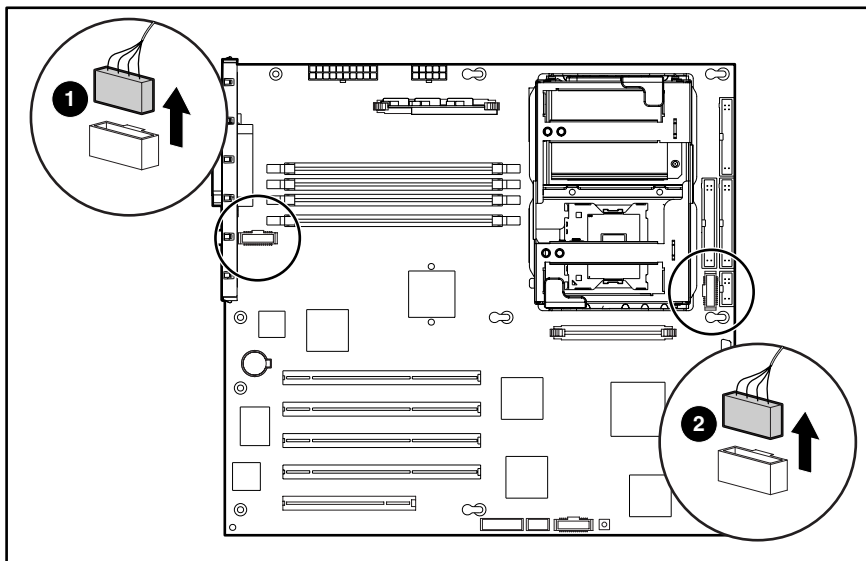

**Figure 2-13: Disconnecting the fan cables from the system board**

6. Loosen the thumbscrew securing the system CPU fan module to the chassis (1).
7. Carefully pull the system CPU fan module away from and out of the chassis (2).

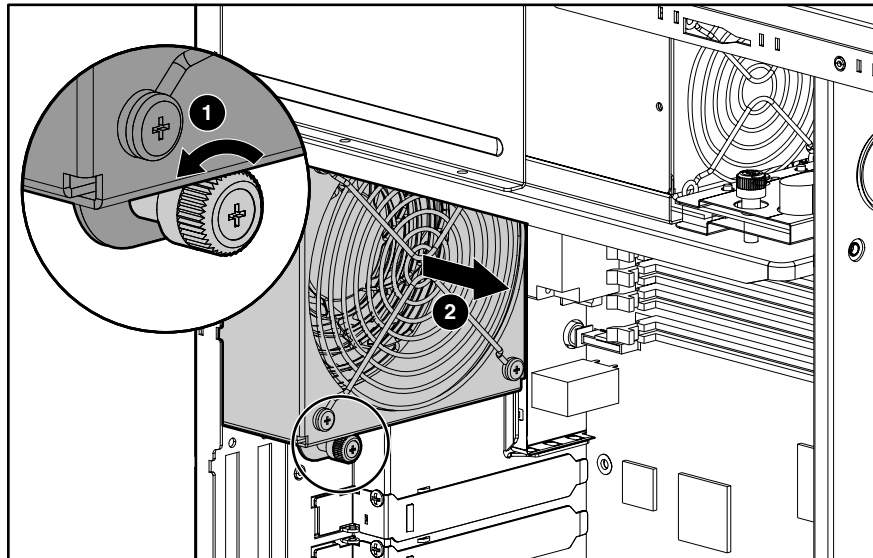

**Figure 2-14: Removing the system CPU fan module**

To replace the system CPU fan module, reverse steps 2 through 7.



To remove the front I/O system fan module:

1. Disconnect the I/O fan cable from the system board (2). Refer to Figure 2-13.

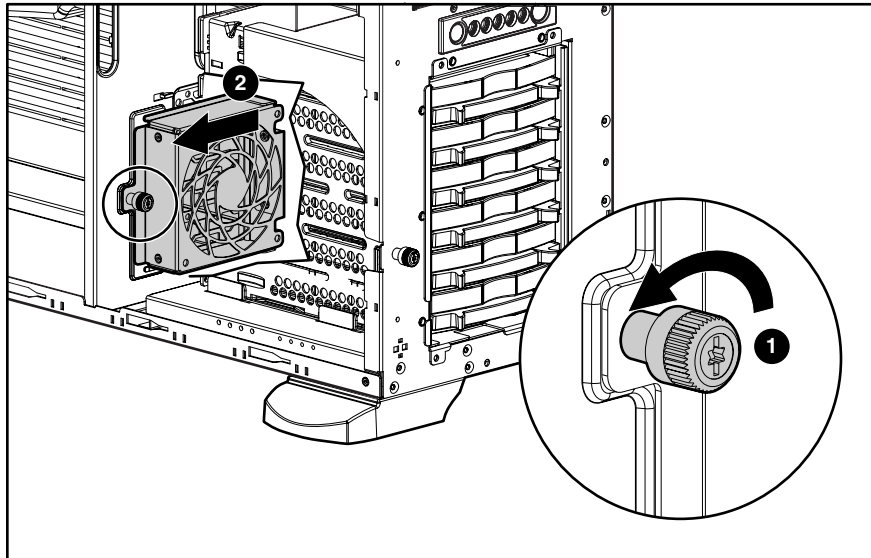

**Figure 2-15: Removing the system I/O fan module**

2. Loosen the thumbscrew securing the I/O fan module to the chassis (1).
3. Carefully lift the I/O fan module out and away from the chassis (2).

To replace the I/O fan module, reverse steps 1 through 3.

## Drive Bay Configuration

The server supports a maximum of ten internal drive bays (four are for removable media devices; six are for hot-plug hard drives). The removable media device bays contain a one-third height, 1.44-MB diskette drive; a one-half height IDE CD-ROM drive; and two empty half-height drive bays. The empty bays may be used for a DVD-ROM drive, tape drive, non-hot-pluggable hard drive, any SCSI device or a 2-bay SCSI drive cage, including a DLT tape drive. A DLT tape drive or the 2-bay SCSI drive cage require both empty half-height drive bays.

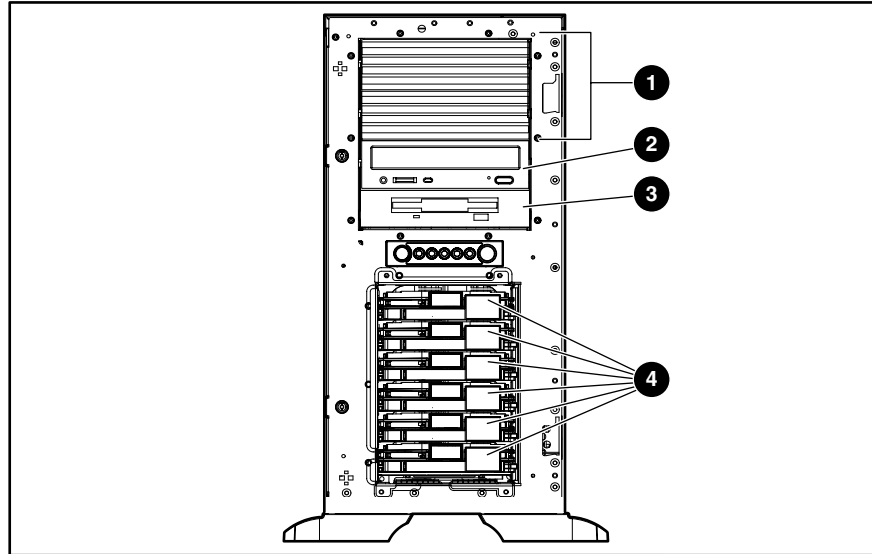

**Figure 2-16: Server drive bay configuration**

**Table 2-2: Drive Bay Configuration**

Item	Description
1	Removable media device bays
2	CD-ROM drive
3	1.44-MB diskette drive
4	Hot-plug hard drive bays

## Hot-Plug Hard Drive Blank

**NOTE:** The server does not need to be powered off to complete this operation.

To remove a hot-plug hard drive blank:

1. Open the bezel door. Refer to “Bezel Door (Tower Model Only)” earlier in this chapter.
2. Slide the release latch to the left (1), and then pull the hot-plug drive blank out of the drive bay (2).

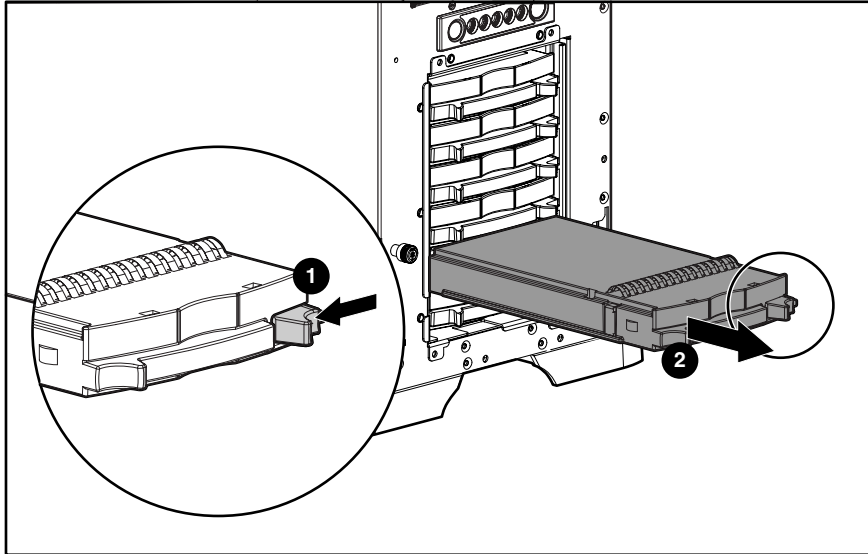

**Figure 2-17: Removing a hot-plug hard drive blank**

To replace a hot-plug hard drive blank, reverse steps 1 and 2.

## Hot-Plug Hard Drive

**NOTE:** The server does not need to be powered off to complete this operation.

To remove a hot-plug hard drive:

1. Open the bezel door. Refer to “Bezel Door (Tower Model Only)” earlier in this chapter.
2. Slide the hard drive release latch (1) to open the ejector lever (2).
3. Pull the hot-plug hard drive out of the drive bay.

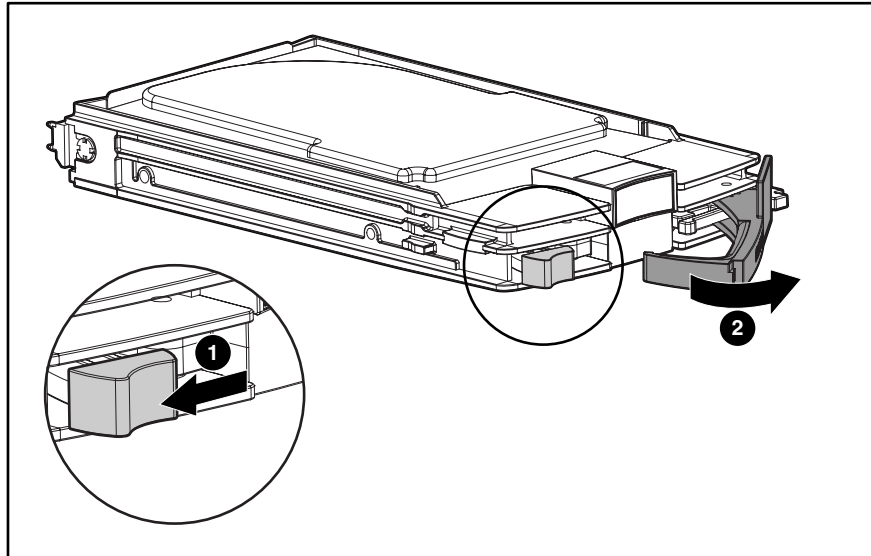

**Figure 2-18: Removing a hot-plug hard drive**

To replace a hot-plug hard drive, push the drive back into the bay and then close the ejector lever to fully seat the drive.

## Hot-Plug Hard Drive Cage

To remove a hot-plug hard drive cage:

1. Complete the preparation procedures. Refer to “Preparation Procedures” earlier in this chapter.
2. Remove the bezel door. Refer to “Bezel Door (Tower Model Only)” earlier in this chapter.
3. Remove the access panel. Refer to “Access Panel” earlier in this chapter.
4. Disconnect the power cable from the back of the hot-plug hard drive cage (1).
5. Disconnect the SCSI cable from the back of the hot-plug hard drive cage and system board (2).

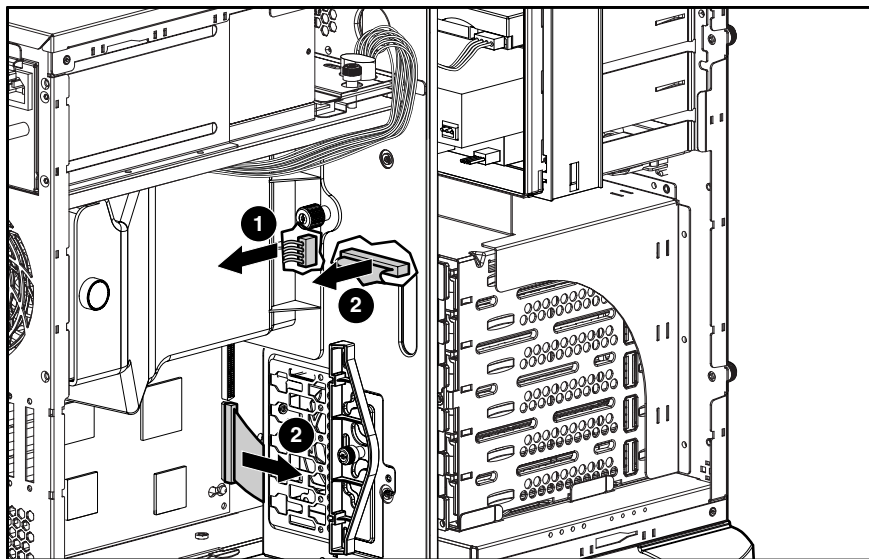

**Figure 2-19: Disconnecting cables from the hot-plug hard drive cage**

6. Remove all drive blanks and hard drives. Refer to “Hot-Plug Hard Drive Blank” and “Hot-Plug Hard Drive” earlier in this chapter.
7. Remove the four screws securing the drive cage to the chassis with a T-15 Torx screwdriver (1).
8. Pull the hot-plug hard drive cage out from the chassis (2).

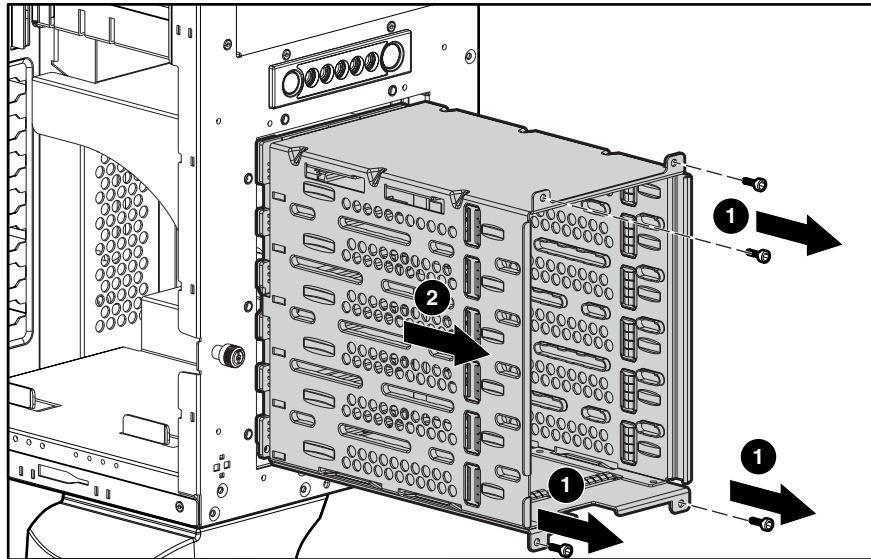

**Figure 2-20: Removing a hot-plug hard drive cage**

To replace a hot-plug hard drive cage, reverse steps 2 through 8.

## Removable Media Device

To remove a removable media device:

1. Complete the preparation procedures. Refer to “Preparation Procedures” earlier in this chapter.
2. Open the bezel door. Refer to “Bezel Door (Tower Model Only)” earlier in this chapter.
3. Remove the access panel. Refer to “Access Panel” earlier in this chapter.
4. Disconnect the cables from the back of the removable media device and the system board.

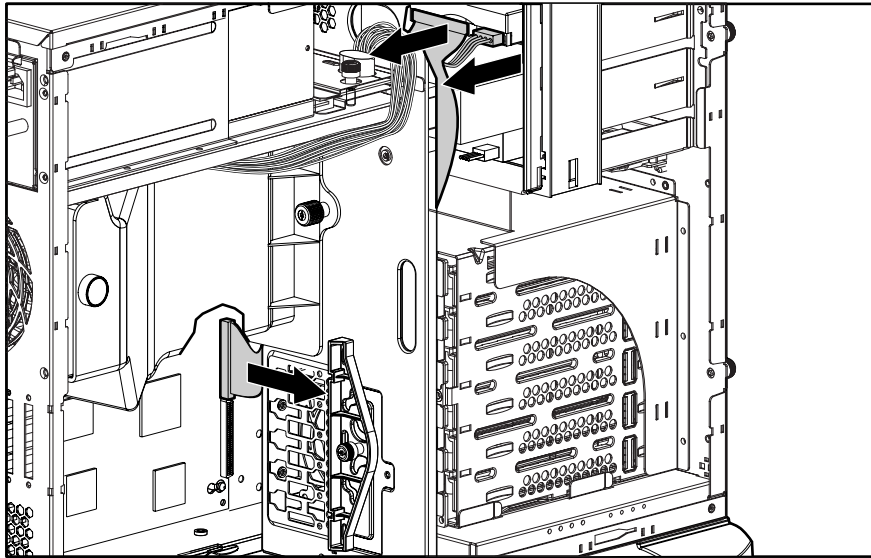

**Figure 2-21: Disconnecting the removable media device cables**

5. While pushing up the drivelock (1), pull the removable media device out of the bay (2).

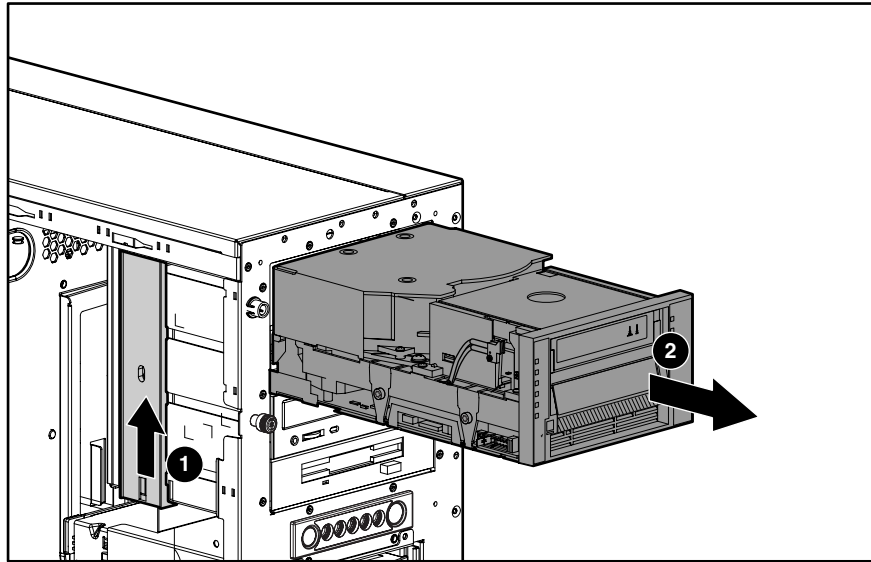

**Figure 2-22: Removing the removable media device**



To replace removable media devices, other than HP StorageWorks AIT or SDLT tape drives, insert the device into the bay until it clicks into place.



**CAUTION:** Install all other options and blanks prior to installing the tape drive.

---



**CAUTION:** If you are replacing HP StorageWorks AIT or SDLT tape drives, be sure to replace the left rear mounting screw with a T-8 Torx screwdriver. Failure to do so prevents proper installation and can damage the tape drive.

---

**NOTE:** It is not necessary to push up on the drivelock when installing a removable media device.

To replace HP StorageWorks AIT or SDLT tape drives:

1. Replace the left rear mounting screw with a T-8 Torx screwdriver, included in the tape drive kit.
2. Insert the device into the bay until the device clicks into place.

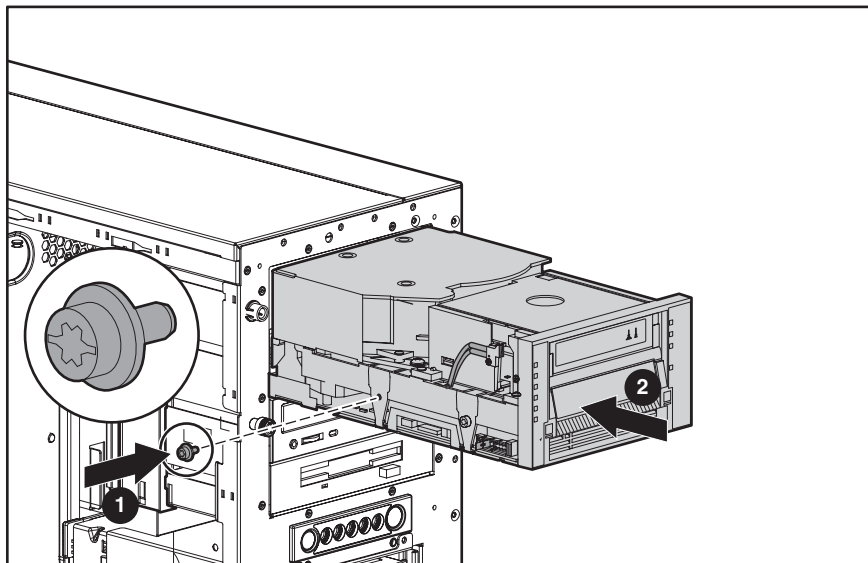

**Figure 2-23: Replacing the tape drive**

## Expansion Slots

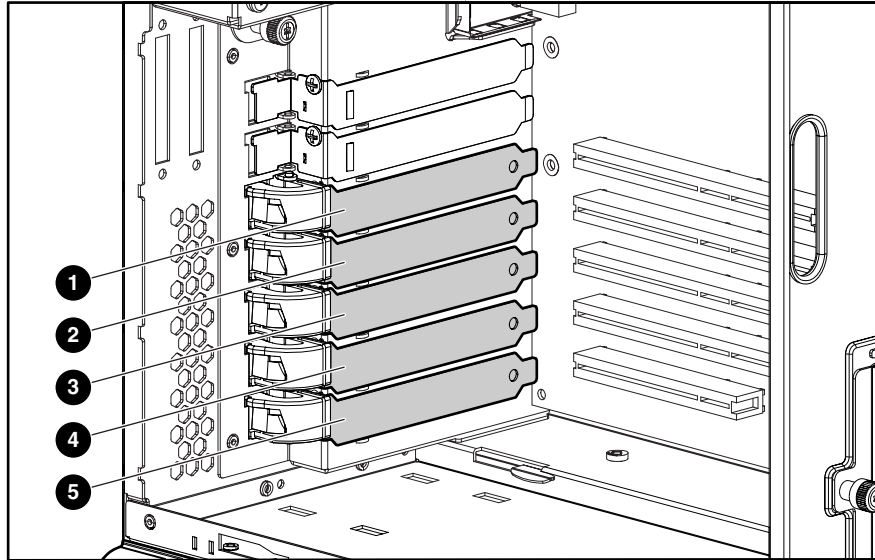

Figure 2-24: Expansion slot locations

Table 2-3: Expansion Slots

Item	Slot	Slot Number
1	64-bit 100-MHz PCI-X, 3.3-V, bus 2	1
2	64-bit 100-MHz PCI-X, 3.3-V, bus 2	2
3	64-bit 100-MHz PCI-X, 3.3-V, bus 5	3
4	64-bit 100-MHz PCI-X, 3.3-V, bus 5	4
5	32-bit 33-MHz PCI, 5-V	5

**Note:** Slots 1, 2, 3 and 4 are optimized for PCI-X 100 add-in cards.

## Expansion Board

To remove an expansion board:

1. Complete the preparation procedures. Refer to “Preparation Procedures” earlier in this chapter.
2. Open the bezel door. Refer to “Bezel Door (Tower Model Only)” earlier in this chapter.
3. Remove the access panel. Refer to “Access Panel” earlier in this chapter.
4. Disconnect any cables connected to the expansion board.
5. If an expansion board retainer is in place:
  - a. Loosen the thumbscrew of the expansion board retainer (1).
  - b. Lift the retainer away from and out of the chassis (2).

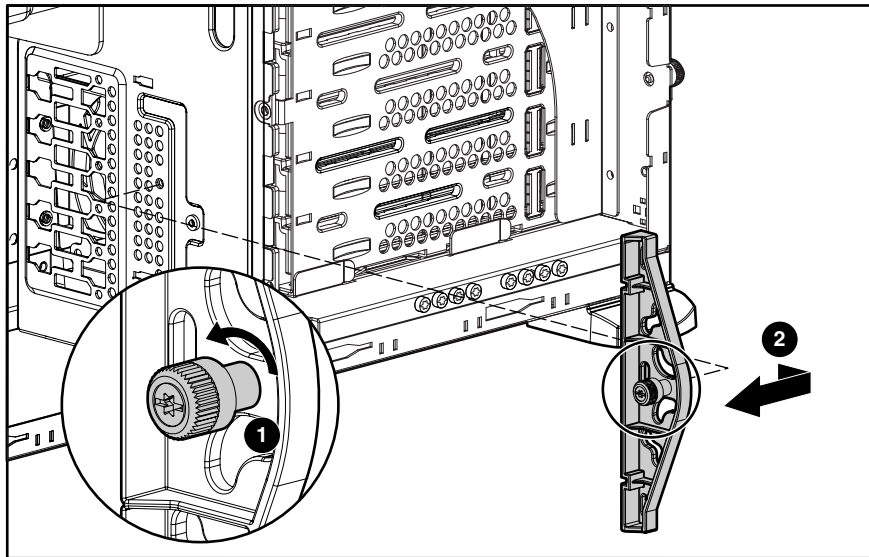
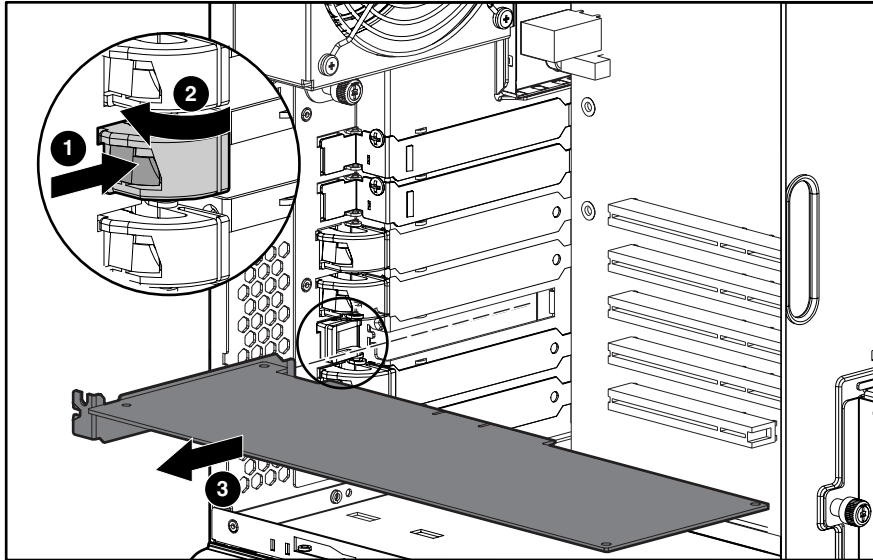

Figure 2-25: Removing the expansion board retainer

6. Press on the top of the expansion slot latch (1) and open the latch toward the rear of the chassis (2).
7. Remove the expansion board (3).
8. Close the expansion slot latch.
9. Replace the expansion board retainer if the expansion board is not immediately being replaced.



**Figure 2-26: Removing the expansion board**

To replace an expansion board, reverse steps 2 through 9.

## Memory Module Guidelines



**CAUTION:** To prevent damage to equipment or loss of information, make sure that the server is powered down, all cables are disconnected from the back of the server, and the power cord is disconnected from the grounded (earthed) AC outlet before removing the access panel.



**CAUTION:** To prevent damage to the system when handling components, refer to the *HP ProLiant ML350 Generation 3 Server Setup and Installation Guide*.



**CAUTION:** When handling a memory module, be careful not to touch any of the contacts. Doing so may damage the module.

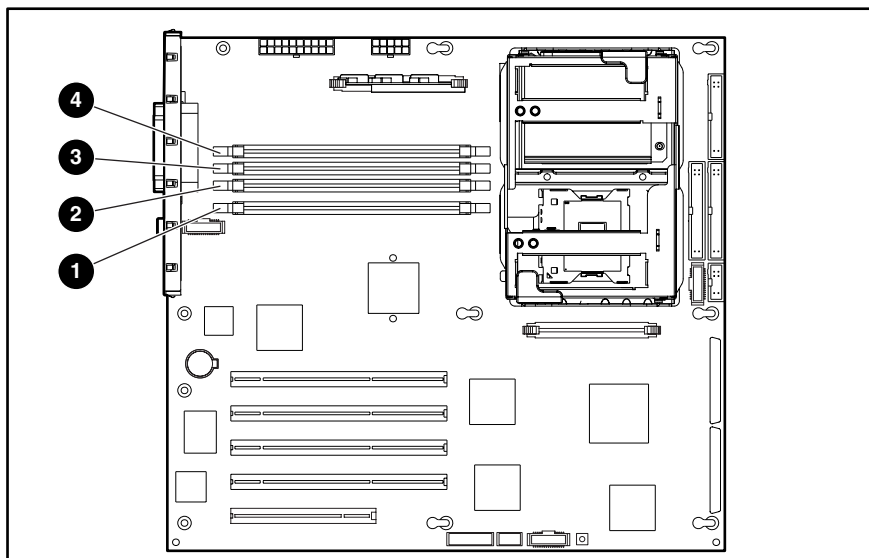

**Figure 2-27: DDR SDRAM DIMM sockets location**

The following guidelines **must** be followed when memory modules are being added or replaced:

- DIMMs must be industry-standard, 256-MB, 512-MB, 1-GB or 2-GB, 3-cm (1.2-inch), 184-pin PC2100, DDR ECC memory DIMMs. The DDR memory DIMMs must support CAS Latency 2, CL=2 or greater. They must also contain the mandatory Joint Electronic Device Engineering Council (JEDEC) Serial Presence Detect (SPD) information.
- If two-way memory interleaving is desired, identical DIMMs must be installed in socket pairs. DIMMs installed in Pair A (sockets 1 and 2), however do not need to be identical to the DIMMs in pair B (sockets 3 and 4). If the two DIMMs within a pair are not identical, the system will automatically run in non-interleaved mode.
- DIMMs installed in the server must be registered DDR, 3.3-volts, 72-bits wide.

- Do not mix ECC and non-ECC DIMMs. If different types of DIMMs are mixed, the system will not properly function.
- A DIMM will only fit one way in the socket. Be sure to match the two key slots in the DIMM with the tabs in the DIMM socket. Push the memory module into the DIMM socket, ensuring that it is fully inserted and properly seated.

## Memory Modules



**CAUTION:** Electrostatic discharge (ESD) can damage electronic components. Be sure that you are properly grounded (earthed) before beginning any installation procedure. Refer to “Electrostatic Discharge Information” earlier in this chapter.

To remove a memory module:

1. Complete the preparation procedures. Refer to “Preparation Procedures” earlier in this chapter.
2. Open the bezel door. Refer to “Bezel Door (Tower Model Only)” earlier in this chapter.
3. Remove the access panel. Refer to “Access Panel” earlier in this chapter.
4. Press both memory module socket latches outward (1). This action releases the module and partially lifts it out of the socket.
5. Lift out the memory module (2).

**IMPORTANT:** A memory module can be installed only one way. Be sure to match the key sockets on the module with the tabs on the memory socket. Push the module down into the socket. Be sure that the module is fully inserted and properly seated.

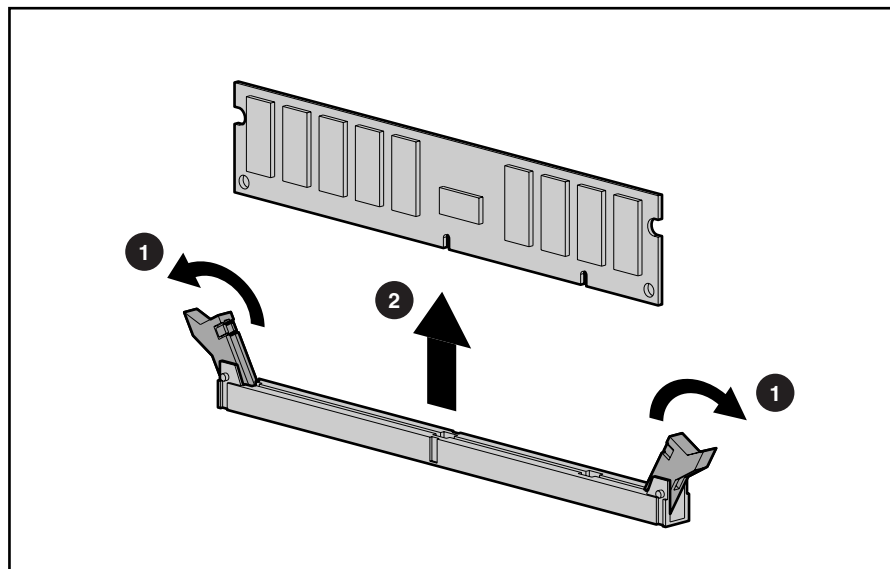

**Figure 2-28: Removing a memory module**

To replace a memory module, reverse steps 2 through 5.

## Processors and Processor Power Modules

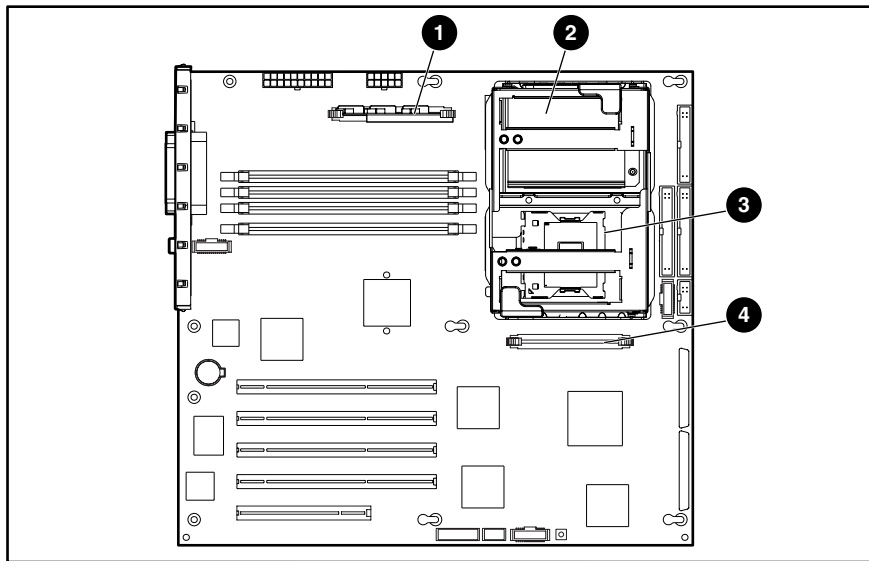

**Figure 2-29: Processor and Processor Power Module (PPM) locations**

**Table 2-4: Processor and Processor Power Module (PPM) Locations**

Item	Description
1	PPM socket 1 (populated)
2	Processor socket 1 (populated)
3	Processor socket 2
4	PPM socket 2

## Processor



**CAUTION:** Electrostatic discharge (ESD) can damage electronic components. Be sure that you are properly grounded (earthed) before beginning any installation procedure. Refer to “Electrostatic Discharge Information” earlier in this chapter.

To remove a processor:

1. Complete the preparation procedures. Refer to “Preparation Procedures” earlier in this chapter.
2. Open the bezel door. Refer to “Bezel Door (Tower Model Only)” earlier in this chapter.
3. Remove the access panel. Refer to “Access Panel” earlier in this chapter.
4. Remove the air baffle. Refer to “Air Baffle” earlier in this chapter.

**IMPORTANT:** For tower models, lay the system on the right side.

5. Locate the processor on the system board.
6. Lift up on the processor-cage retaining latch.

**IMPORTANT:** The lever must be perpendicular to the board or socket for the processor to unlock.

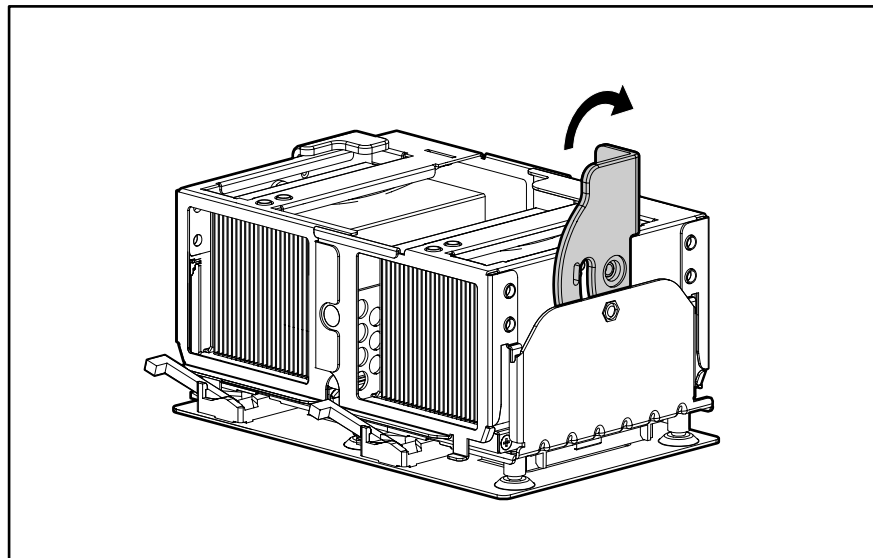

**Figure 2-30: Releasing the processor-cage latch**



7. Rotate the processor cage upward.

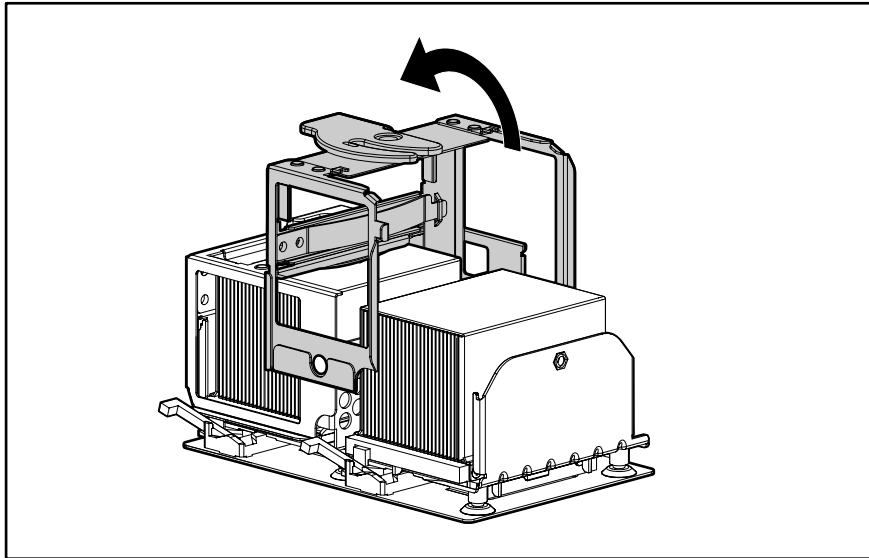

**Figure 2-31: Rotating the processor cage**

8. Rotate the processor-locking lever to release the processor.

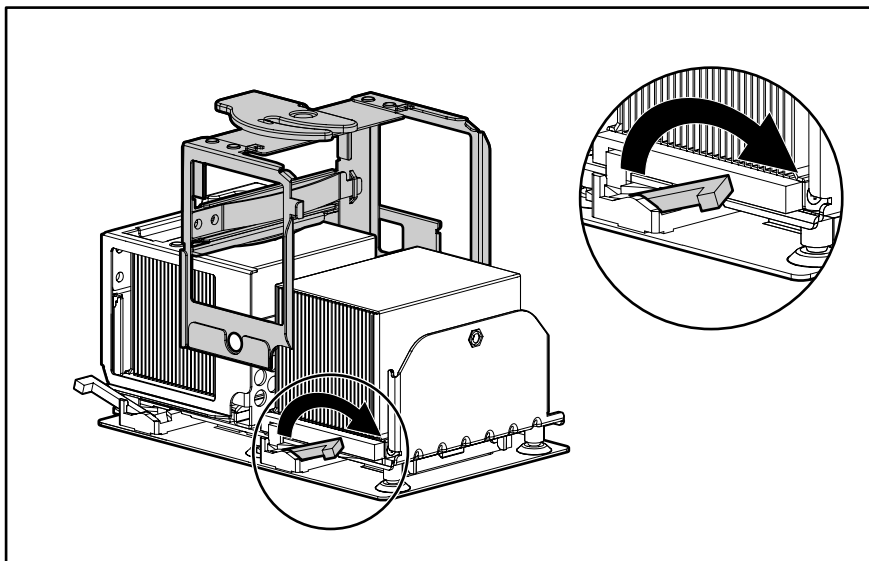

**Figure 2-32: Releasing the processor-locking lever**

9. Remove the processor/heatsink assembly from the socket.

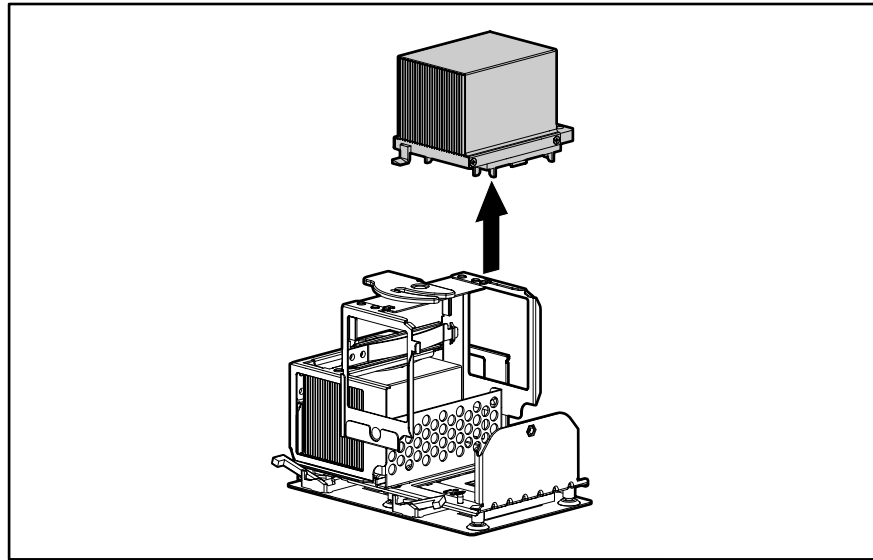

**Figure 2-33: Removing the processor/heatsink assembly**



**CAUTION:** Failure to fully open the processor locking lever will prevent the processor from seating properly during installation and can potentially lead to hardware damage.



**CAUTION:** To prevent possible server malfunction, be sure to completely close the processor locking lever.

To replace the processor, reverse steps 2 through 9.

## Processor Power Module



**WARNING:** To reduce the risk of personal injury from hot surfaces, allow the internal system components to cool before touching them.

---

To remove a Processor Power Module (PPM):

1. Complete the preparation procedures. Refer to “Preparation Procedures” earlier in this chapter.
2. Open the bezel door. Refer to “Bezel Door (Tower Model Only)” earlier in this chapter.
3. Remove the access panel. Refer to “Access Panel” earlier in this chapter.
4. Locate the PPM to be removed.
5. Press the latches outward to release the PPM (1).
6. Lift the PPM away from the socket (2).

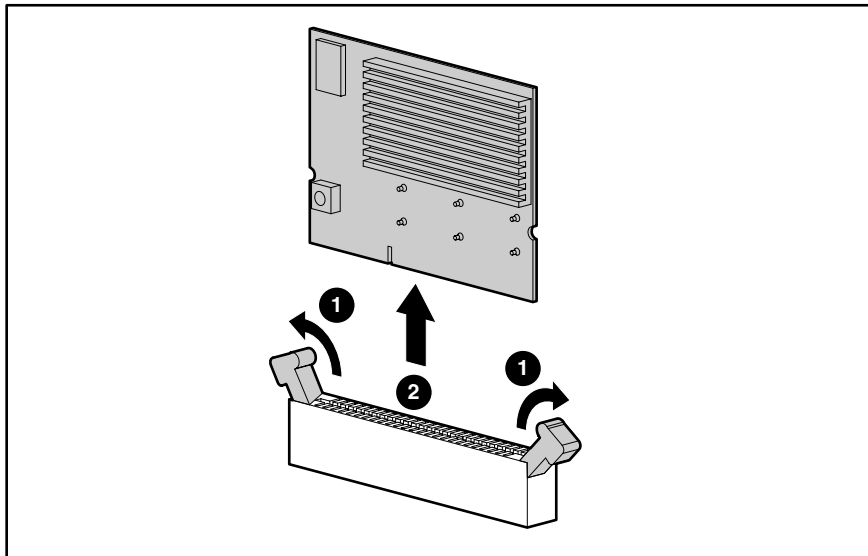

**Figure 2-34: Removing a Processor Power Module (PPM)**

To replace a PPM, reverse steps 2 through 6.

## System Board

To remove the system board:

1. Complete the preparation procedures. Refer to “Preparation Procedures” earlier in this chapter.
2. Open the bezel door. Refer to “Bezel Door (Tower Model Only)” earlier in this chapter.
3. Remove the access panel. Refer to “Access Panel” earlier in this chapter.
4. Remove the air baffle. Refer to “Air Baffle” earlier in this chapter.

**IMPORTANT:** For tower models, lay the system on the right side.

5. Remove the CPU fan module. Refer to “System Fan Modules” earlier in this chapter.
6. Disconnect all power cables, device cables, and the power button cable from the system board. Refer to “Cable Routing Diagrams” earlier in this chapter.
7. Remove all expansion board(s) and memory modules. Refer to “Expansion Board” and “Memory Modules” earlier in this chapter.
8. Remove all processors and Processor Power Modules (PPMs). Refer to “Processors and Processor Power Modules” earlier in this chapter.
9. Remove the four screws securing the system board to the chassis with a T-15 Torx screwdriver (1).
10. Push the system board toward the front of the unit until the board stops (2).
11. Holding the system board from the edges, lift up the rear of the system board, pulling up and away from the chassis (3).

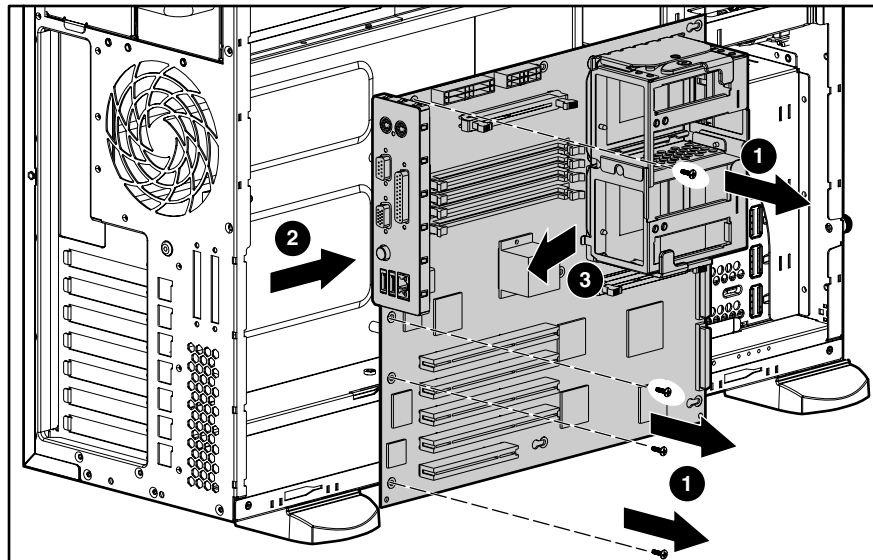

**Figure 2-35: Removing the system board**

To replace the system board, reverse steps 2 through 11.

**IMPORTANT:** The server serial number must be re-entered through RBSU after replacing the system board. Refer to “Re-entering the Server Serial Number” in this chapter.

## Re-entering the Server Serial Number

After replacing the server host module or clearing the NVRAM, the server serial number must be re-entered. To re-enter the serial number:

During the server startup sequence, press the **F9** key to access RBSU.

1. Select the **System Options** menu.
2. Select **Serial Number**. The following warning is displayed:

WARNING! WARNING! WARNING! The serial number is loaded into the system during the manufacturing process and should NOT be modified. This option should ONLY be used by qualified service personnel. This value should always match the serial number sticker located on the chassis.

Press the **Enter** key to clear the warning.

3. Enter the serial number and press the **Enter** key.
4. Press the **Escape** key to close the menu.
5. Press the **Escape** key to exit RBSU.
6. Press the **F10** key to confirm exiting RBSU. The server will automatically reboot.

## System Battery

The server uses nonvolatile memory that requires a battery to retain system information when power is removed. The battery is on the system board.

## System Board Battery

If the server no longer automatically displays the correct date and time, the system board battery that provides power to the real-time clock may need to be replaced. Under normal use, battery life is 5 to 10 years.



**WARNING:** The system board contains a lithium battery. There is a risk of fire and chemical burn if the battery is improperly handled. Do not disassemble, crush, puncture, or short external contacts, dispose of in water or fire, or expose the battery to temperatures higher than 60°C (140°F).

---



**CAUTION:** Static electricity can damage the electronic components of the server. Before beginning these procedures, be sure that you are discharged of static electricity by briefly touching a grounded (earthed) metal object. Refer to “Electrostatic Discharge Information” earlier in this chapter.

---

To replace the system board battery:

1. Complete the preparation procedures. Refer to “Preparation Procedures” earlier in this chapter.
2. Open the bezel door. Refer to “Bezel Door (Tower Model Only)” earlier in this chapter.
3. Remove the access panel. Refer to “Access Panel” earlier in this chapter.
4. Locate the battery on the system board.
5. Press the battery release lever away from the battery (1).
6. Lift the battery up from that side and out of its holder (2).

**IMPORTANT:** The battery should be installed with the positive polarity (+ side) positioned up.

**NOTE:** If expansion boards are installed, you may need to remove them to gain access to the battery.

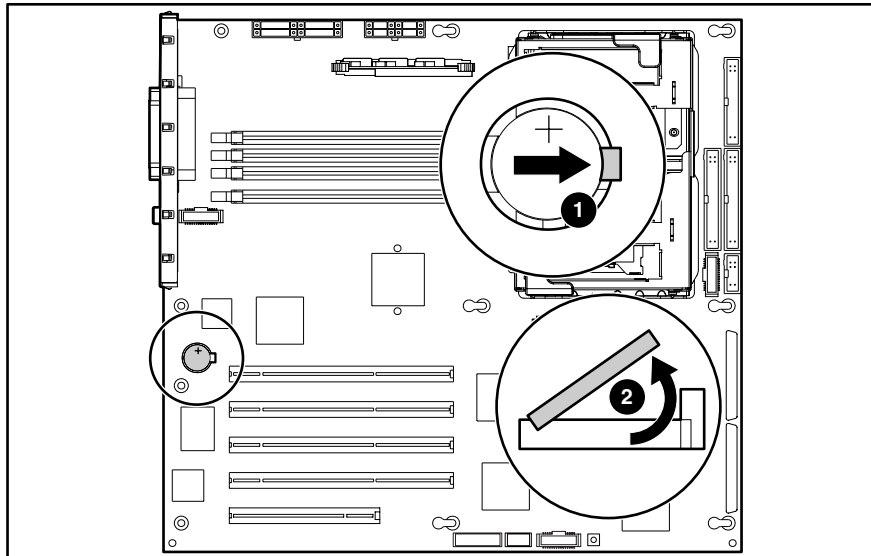

**Figure 2-36: Locating and removing a system board battery**

## Power Supply

To remove the power supply:

**IMPORTANT:** The power supply of the server is hot-pluggable. When removing a power supply, do not power down the server when the redundant power supply option is used.

1. Remove the power cord from the power supply to be removed from the server.
2. Push down on the power supply release latch (1).
3. Slide the power supply out of the server (2).

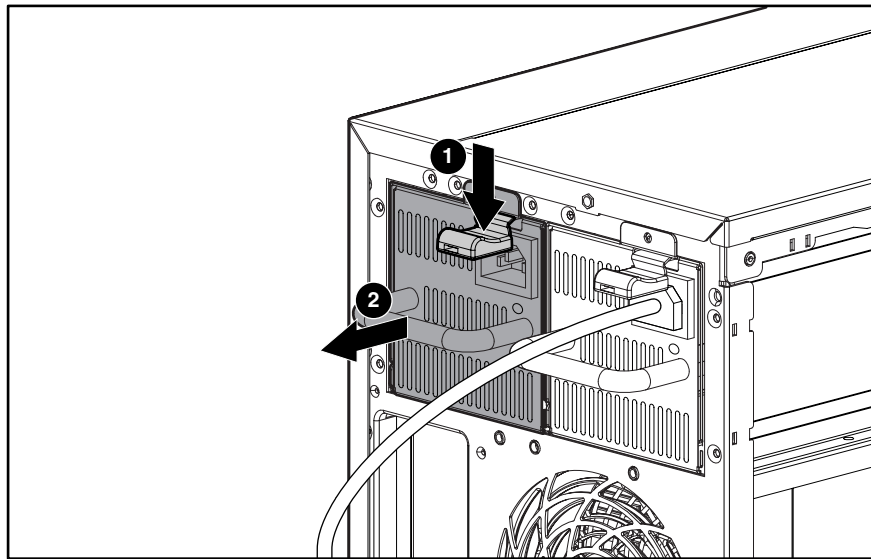

**Figure 2-37: Removing the power supply (shown with optional redundant power supply)**

To replace the power supply, reverse steps 1 through 3.



## Power Supply Backplane Board

To remove the power supply backplane board:

1. Complete the preparation procedures. Refer to “Preparation Procedures” earlier in this chapter.
2. Remove the access panel. Refer to “Access Panel” earlier in this chapter.
3. Remove any installed power supplies. Refer to “Power Supply” in the previous section.
4. Remove all cables from the power supply backplane board.
5. Loosen the thumbscrew securing the power supply backplane board to the server chassis (1).
6. Slide the power supply backplane board slightly toward the open side of the chassis to release the power supply backplane board from the mounting posts, and then lift the board up and out of the chassis (2).

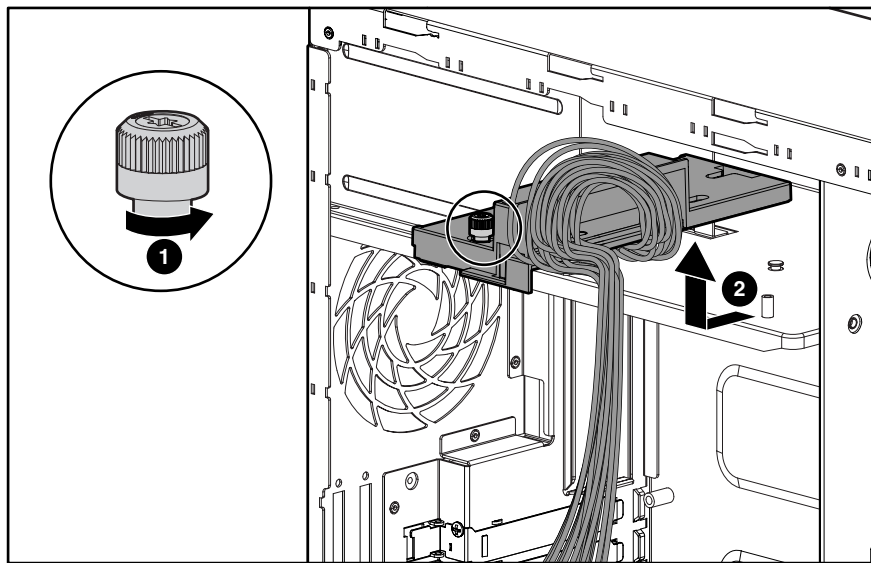

**Figure 2-38: Removing the power supply backplane board**

To replace the power supply backplane board, reverse steps 2 through 6.

## Feet (Tower Model Only)

To remove the four feet from the chassis, one at a time:

1. Complete the preparation procedures. Refer to “Preparation Procedures” earlier in this chapter.
2. Place the server upside down.
3. Remove the T-15 Torx screw that secures each foot to the chassis (1).
4. Lift up the other end of each foot (2) and pull it off the base of the chassis (3).

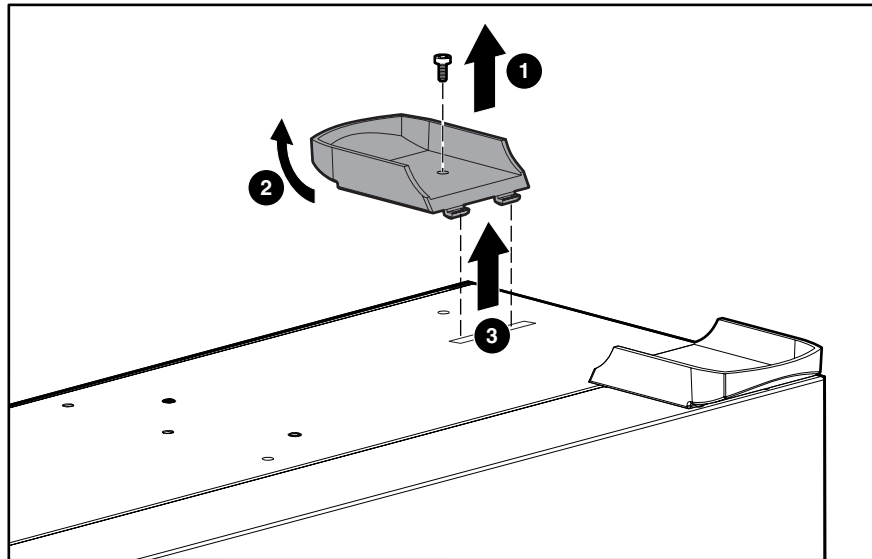

**Figure 2-39: Removing the feet from the chassis**

To replace the feet, reverse steps 2 through 4.

## Diagnostic Tools

This chapter provides an overview of the software and firmware diagnostic tools available for the HP ProLiant ML350 Generation 3 server.

### Diagnostic Tools Utility Overview

The following utilities were developed to assist in diagnosing problems, testing the hardware, and monitoring and managing the server hardware.

**Table 3-1: Diagnostic Tools**

Tool	Description	How to run it
Diagnostics Utility	Utility to assist testing and/or verifying operation of HP hardware. If problems are found, the Diagnostics Utility isolates failures down to the replaceable part, whenever possible.	<p>Diagnostics and utilities must be accessed when a system configuration error is detected during Power-On Self-Test (POST). For a complete list of POST error messages, refer to the <i>Servers Troubleshooting Guide</i>.</p> <p>Diagnostics software is also available on the HP SmartStart software CD. A Diagnostics diskette may be created from the SmartStart software CD. Diagnostics can then be run from the diskette.</p>
Insight Manager application	A client/server application that remotely manages HP systems in a network environment. Reports hardware fault conditions (both failure and prefailure) and collects data for reporting and graphing.	For more information, refer to the <i>HP Insight Manager User Guide</i> . Documentation for Insight Manager is available on the Management CD in <i>CD-ROM DRIVE: \OVERVIEW.HLP</i>

*continued*

**Table 3-1: Diagnostic Tools** *continued*

Tool	Description	How to run it
Survey Utility	<p>An online information-gathering program that runs on servers, gathering critical hardware and software information from various sources. A utility for servers running Microsoft® Windows NT®, Linux, or Novell NetWare.</p> <p>If a significant change occurs between data-gathering intervals, previous information is marked, and the survey text file is appended to reflect the latest configuration and changes since the last configuration. This utility provides a historical record of change events for server hardware and software.</p>	<p>Survey Utility automatically runs at startup and user-specified time intervals. Modify the command-line parameters to change the data-gathering interval.</p> <p>For more information on Survey Utility, including installation and application procedures, refer to the <i>HP Survey Utility Online Help User Guide</i> accessed through:  <a href="http://www.hp.com/servers/proliant/manage">www.hp.com/servers/proliant/manage</a>            Perform a search for “Survey Utility”, then follow the appropriate link.</p>
SmartStart software	<p>Located on the SmartStart CD, the SmartStart utility is the intelligent way to set up your HP server. The SmartStart CD is used to load the system software, thereby achieving a well-integrated server and ensuring maximum dependability and supportability. The SmartStart CD contains diagnostic utilities and ROMPaq tools.</p>	<p>Power up from the SmartStart Software for Servers CD.</p>
SmartStart Diskette Builder	<p>Creates a diskette version of the utility from the SmartStart CD. The support diskettes include the following:</p> <ul style="list-style-type: none"> <li>• Array Configuration Utility (ACU)</li> <li>• Operating System support</li> <li>• Server Utilities</li> <li>• Erase Utility</li> </ul>	<p>Use a workstation running Windows XP®, Windows 95, Windows 98, Windows NT, or Windows 2000. You also need several 1.44-MB diskettes. Insert the SmartStart CD into the workstation drive. The CD automatically runs the Diskette Builder Utility; however, if the server does not support the “auto-run” feature, use Windows Explorer to run <i>CD-ROM DRIVE: \DSKBLDR\DSKBLDR.EXE</i>.</p>
ROMPaq Utility	<p>Utility that upgrades the current system ROM.</p>	<p>Insert a ROMPaq diskette into the diskette drive, remove power from the server, and then power up the server again.</p>

*continued*

**Table 3-1: Diagnostic Tools** *continued*

Tool	Description	How to run it
System Firmware Update	Utility that enables Windows NT 4 and Windows 2000 to efficiently update system and array controller ROMs on remote servers from a central location.	Latest maintenance ROM executable file can be downloaded from <a href="http://www.hp.com/servers/proliant/manage">www.hp.com/servers/proliant/manage</a>
ROM-Based Setup Utility (RBSU)	<p>Utility used to configure some hardware installed in or connected to the server. Specifically, it can:</p> <ul style="list-style-type: none"> <li>• Resolve resource conflicts in areas such as memory, port addresses, and interrupts (IRQs)</li> <li>• Configure PCI boards automatically.</li> <li>• Manage installation of memory, processor upgrades, and mass storage devices such as hard drives, tape drives, and diskette drives</li> <li>• Store configuration information in nonvolatile memory</li> <li>• Configure the platform for an operating system</li> </ul>	Run RBSU directly from the system ROM by pressing the <b>F9</b> key when prompted during POST.
Automatic Server Recovery (ASR)	<p>A tool that restarts the server automatically after a catastrophic operating system failure, including software errors, OS lockups, environmental abnormalities, and some hardware errors.</p> <p>A system failsafe timer, the ASR timer, is started when the HP System Management driver, also known as the health driver, is loaded. The Insight Manager console notifies you in the event of an ASR restart. Disable the ASR from the Insight Manager console.</p>	This tool is a function of the hardware/software system through RBSU. Verify that this tool is enabled through RBSU. The systems management drive must be loaded to activate ASR.
POST	The POST is a series of diagnostic tests that checks firmware and assemblies to ensure that the server is properly functioning.	POST runs automatically on HP servers when the server is powered up.

*continued*

**Table 3-1: Diagnostic Tools** *continued*

<b>Tool</b>	<b>Description</b>	<b>How to run it</b>
INSPECT	A utility that provides a report detailing system information.	INSPECT can be run from the Diagnostics program.
Integrated Management Log (IML)	A log of system events, such as system failures or nonfatal error conditions. View events in the IML from within: <ul style="list-style-type: none"><li>• Insight Manager</li><li>• Survey utility</li><li>• OS-specific IML utilities</li></ul>	The IML requires operating system-dependent drivers. Refer to the Software Support CD for instructions on installing the appropriate drivers.
Array Diagnostics Utility (ADU)	A Windows-based tool designed to run on all HP systems that support HP array controllers. The main functions of ADU are to collect all possible information about the array controllers in the system and to generate a list of detected problems.	Power up the SmartStart for Servers CD or use the Diskette Builder (also located on the CD) to create ADU bootable diskettes.  Use the information provided in the ADU.  For a complete list of ADU error messages, refer to the <i>Servers Troubleshooting Guide</i> .

## For More Information

For detailed information about each of these diagnostic tools, refer to the *Servers Troubleshooting Guide* on the documentation CD. For the most recent version of this guide, go to

[www.hp.com](http://www.hp.com)

---

## Connectors, Switches, and LEDs

This chapter contains illustrations and tables identifying and describing connectors, switches, and LED locations on the front panel, rear panel, system board and hard drives for the HP ProLiant ML350 Generation 3 server.

## Connectors and Components

This section contains illustrations and tables identifying connector locations and components on the server rear panel and system board.

### Rear Panel Components

Figure 4-1 and Table 4-1 show and describe the location of the components on the rear panel of the server.

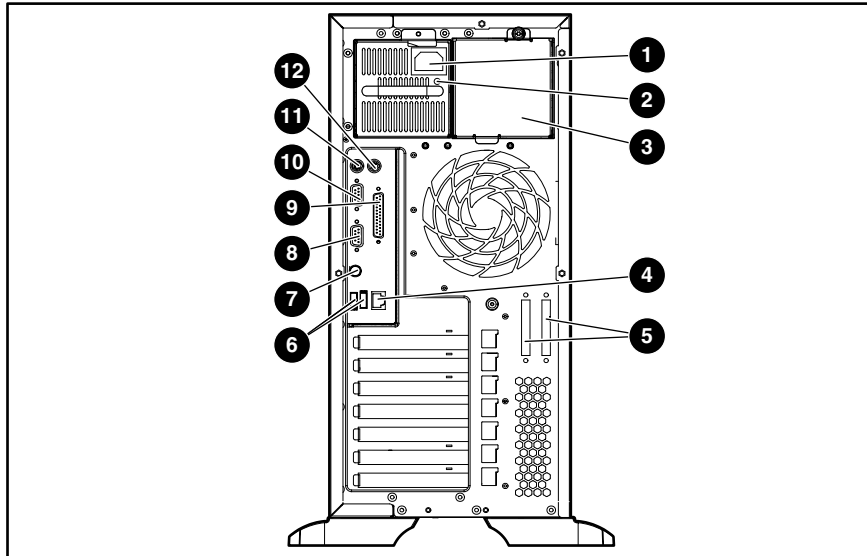

Figure 4-1: Rear panel components

Table 4-1: Rear Panel Components

Item	Description	Item	Description
1	Power cord connector	7	Unit Identification (UID) LED/button
2	Power supply LED	8	Video connector
3	Optional redundant power supply bay	9	Parallel port connector
4	RJ-45 Ethernet connector	10	Serial port connector
5	SCSI connector knockouts	11	Keyboard connector
6	USB port connectors (2)	12	Mouse connector



## System Board Components

Figure 4-2 and Table 4-2 show and describe the location of the components on the server system board.

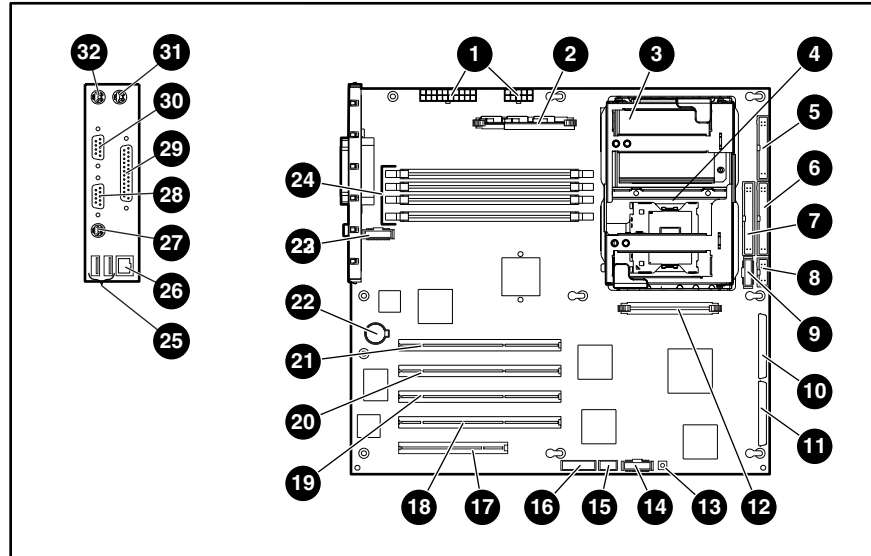

**Figure 4-2: System board components**

**Table 4-2: System Board Components**

Item	Description	Item	Description
1	Power supply connectors	17	32-bit 33-MHz PCI slot
2	(PPM) Module socket 1 (populated)	18	64-bit 100-MHz PCI-X slot, bus 5
3	Processor socket 1 (populated)	19	64-bit 100-MHz PCI-X slot, bus 5
4	Processor socket 2	20	64-bit 100-MHz PCI-X slot, bus 2
5	Diskette drive connector	21	64-bit 100-MHz PCI-X slot, bus 2
6	Primary IDE connector	22	Battery
7	Secondary IDE	23	CPU fan connector (rear)
8	Power button connector	24	DIMM sockets
9	I/O fan connector (front)	25	USB port connectors
10	Secondary B SCSI	26	RJ-45 Ethernet connector
11	Primary A SCSI	27	Unit ID LED/button
12	(PPM) Module socket 2	28	Video connector
13	Non-maskable interrupt (NMI) switch	29	Parallel port connector
14	RILOE II connector (30 pin)	30	Serial port connector
15	System ID switch	31	Mouse connector
16	System configuration switch	32	Keyboard connector

## Switches

### System Configuration Switch Settings

The server system board has two sets of switches, an 8-position configuration switch and a 4-position system ID switch. Figure 4-3, Table 4-3, and Table 4-4 show and describe the use of each switch.

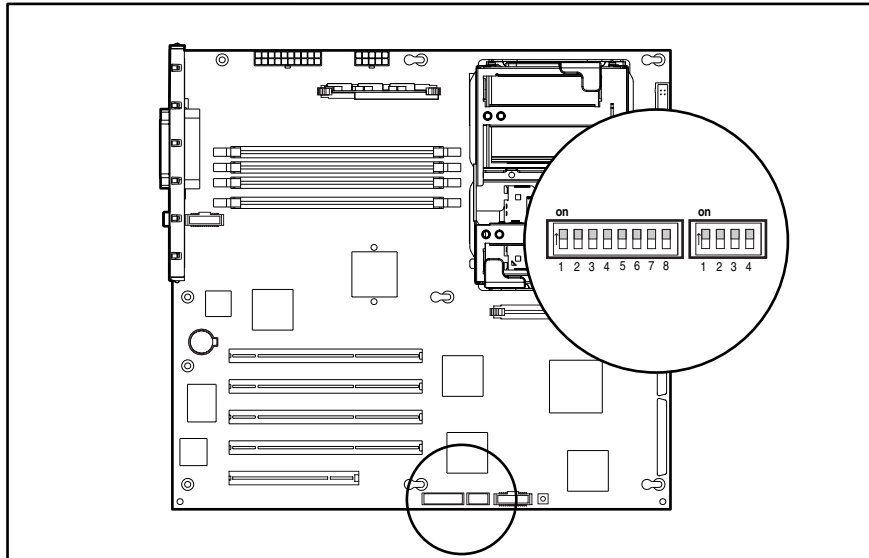

**Figure 4-3: System configuration switch settings**

**Table 4-3: System Configuration Switch Settings**

Switch	Default Position	Function	Description	Settings
1	Off	Reserved	N/A	N/A
2	Off	Lock configuration	Enables or disables the ability to write to NVRAM to reconfigure the system	Off = Configuration may be changed. On = Configuration is locked and cannot be changed.
3	Off	Tower or rack configuration	Specifies a tower or rack configuration	Off = Tower configuration On = Rack configuration
4	Off	Enable diskette boot	Enables or disables booting from the diskette drive	Off = Diskette drive boot is controlled by the configuration. On = Diskette boot is disabled.
5	Off	Password disable	Disables password	Off = Password is enabled. On = Password is disabled.
6	Off	Clear CMOS and NVRAM	Clears system configuration settings	Off = Normal On = When server is powered up, all system configuration information is erased.
7	Off	Reserved	N/A	N/A
8	Off	Reserved	N/A	N/A

**Note:** Switch positions 7 and 8 are reserved for HP authorized service providers only. Do not change the specified default setting for these positions, unless instructed otherwise.

**Table 4-4: System ID Switch Settings**

Position	Default	Function/Description
1	Off	Reserved
2	Off	Reserved
3	Off	Reserved
4	Off	Reserved

## Resetting System Configuration Settings

It may be necessary at some time to clear and reset system configuration settings. When the system configuration switch position 6 is set to the **on** position, the system is prepared to erase all system configuration settings from both CMOS and nonvolatile RAM (NVRAM):

**IMPORTANT:** Clearing NVRAM deletes the configuration information. Refer to the *HP ProLiant ML350 Generation 3 Server Setup and Installation Guide* for complete instructions on configuring the server.

1. Power down the server.
2. Set the system configuration switch position 6 to the **on** position.
3. Power up the server. All configuration settings are now erased and all system operations halt.
4. Power down the server.
5. Reset the position 6 switch to the default **off** position.
6. Power up the server.
7. Reset all system configuration settings.

Refer to Chapter 3 of this guide, “Diagnostic Tools,” or refer to the *HP ROM-Based Setup Utility User Guide* found on the server documentation CD for more information on RBSU.

## LEDs

Several status LEDs and buttons are located on the front and back of the server. Problem diagnosis is aided by the LEDs that indicate the status of the components and operations of the server. LEDs are also located on the system board. The following server LEDs and buttons are explained in this section:

- Power button
- System status LEDs (on the front of the server)
  - Power On/Standby and AC power status
  - Network Interface Controller (NIC) activity
  - External health
  - Internal health
  - Unit Identification
- Unit Identification (UID) button
- System board LEDs
  - Processor failure
  - Processor Power Module (PPM) failure
  - Memory failure
  - Thermal failure
  - Fan failure
- Hot-plug hard drive LEDs
- Network Interface Controller LEDs (on the back of the server)
  - Network activity status
  - Network link
  - Connection speed

## Power Button, System Status LEDs, and Unit Identification Button

The power button, system status LEDs, and Unit Identification (UID) button are located on the front of the server.

The power button:

- Powers up the server.
- Places the server in standby mode.
- Powers down the server.

The following system status LEDs are explained:

- Power On/Standby status
- NIC
- External health
- Internal health
- UID
- Hard drive status

The UID button:

- Activates identification.
- Deactivates identification.
- Indicates activation remotely.

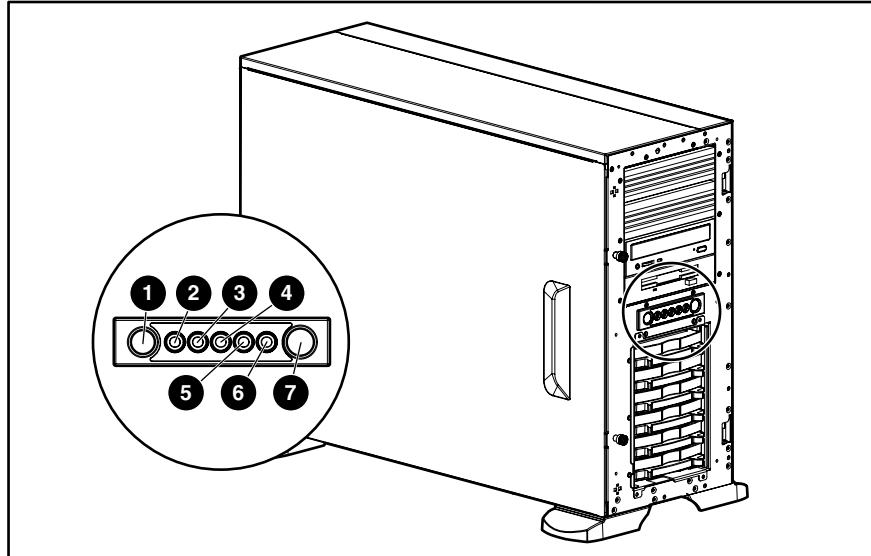

**Figure 4-4: Power button, system status LEDs, and UID button**

**Table 4-5: Power Button, System Status LEDs, and Unit Identification Button**

Item	Description	Status	Description
1	UID button	N/A	Allows the user to activate or deactivate unit identification. Pushing the button activates unit identification, shown by the blue UID LED, so that the onsite administrator can identify a particular server.
2	UID LED	Off	Identification off
		Blue	Identification on
		Flashing blue	Remote console activity
3	Internal health	Off	System off and last health good
		Green	System on, AC power available, health good
		Amber	System degraded; system on or system off with auxiliary power
		Red	System critical; system on or system off with auxiliary power
4	External health	Off	System off
		Green	System on; AC power available
		Amber	System degraded; on or off with auxiliary power (One redundant power supply has failed)
		Red	System critical; on or off with auxiliary power

*continued*

**Table 4-5: Power Button, System Status LEDs, and Unit Identification Button**  
*continued*

Item	Description	Status	Description
5	NIC LED	Off	No connection
		Green	Linked to network
		Flashing green	System linked and activity present on network
6	Power On/Standby and AC power status LED	Off	System off, no AC power
		Amber	System is shut down but power is applied
		Green	System is on with AC power applied
7	Power button	N/A	Allows the user to power up the server, place the server in standby mode, and power down the server.



**CAUTION:** When the power LED is green, it is unsafe to remove AC power from the system without performing a proper shutdown of the operating system.



## System Board LEDs

Figure 4-5 and Table 4-6 show and describe LEDs on the system board of the server that indicate when a processor, PPM, memory module, or fan fails. System board LEDs also indicate when the Server Feature Board is not properly seated or when a thermal threshold is exceeded.

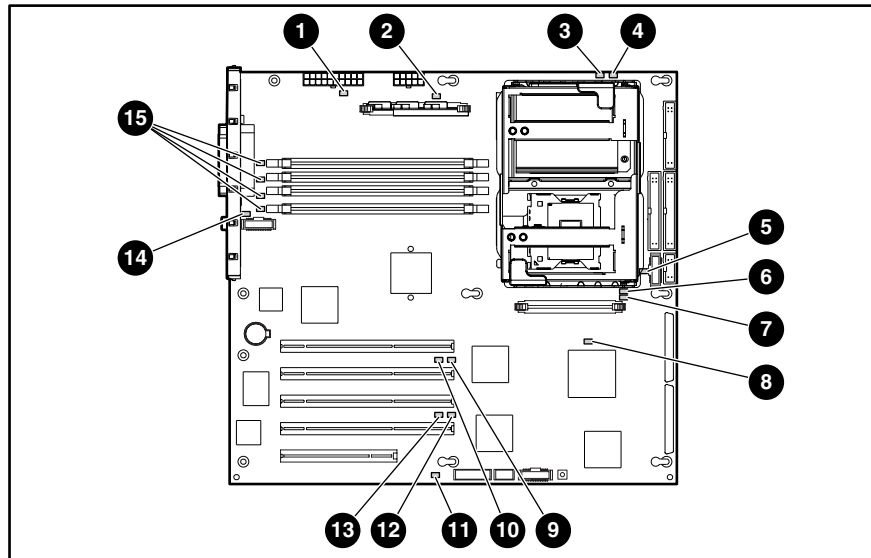

Figure 4-5: System board LEDs

Table 4-6: System Board LEDs

Item	Description	Status
1	AC power	Off = No AC power, poor power supply, or power supply current limits exceeded  Green = Power supply is powered on and functioning, or power supplied by auxiliary power
2	PPM 1 status	Off = PPM 1 functioning  Amber = PPM 1 failed
3	Processor 1 thermal	Off = Normal  Amber = Thermal trip detected for processor 1. Refer to the <i>HP ProLiant ML350 Generation 3 Server Setup and Installation Guide</i> for the appropriate instructions.
4	Processor 1 status	Off = Processor 1 functioning  Amber = Processor 1 failed

*continued*

**Table 4-6: System Board LEDs** *continued*

Item	Description	Status
5	I/O fan status	Off = Fan functioning Amber = Fan is not installed or has failed
6	Processor 2 status	Off = Processor 2 functioning Amber = Processor 2 failed
7	Processor 2 thermal	Off = Normal Amber = Thermal trip detected for processor 2. Refer to the <i>HP ProLiant ML350 Generation 3 Server Setup and Installation Guide</i> for the appropriate instructions.
8	PPM 2 status	Off = PPM 2 functioning Amber = PPM 2 failed
9	PCI-X bus 2 speed	Off = PCI 33 MHz/PCI-X 66 MHz operating mode On = PCI 66 MHz/PCI-X 100 MHz operating mode
10	PCI-X bus 2 mode	Off = PCI-X mode is inactive On = PCI-X mode is active
11	Temperature threshold	Off = Normal Amber = Temperature threshold exceeded
12	PCI-X bus 5 speed	Off = PCI 33 MHz/PCI-X 66 MHz operating mode On = PCI 66 MHz/PCI-X 100 MHz operating mode
13	PCI-X bus 5 mode	Off = PCI-X mode is inactive On = PCI-X mode is active
14	CPU fan status	Off = Fan functioning Amber = Fan is not installed or has failed
15	DIMM status (DIMM slots 1 through 4)	Off = DIMM functioning Amber = DIMM failed

## Hot-Plug Hard Drive LEDs

The hot-plug SCSI hard drive LEDs, located on each physical drive, are visible on the front of the server or external storage unit. They provide status information regarding drive activity (1), connectivity (2), and fault (3) status for each corresponding drive when configured as part of an array and connected to an array controller. Their behavior may vary, depending on the status of other drives in the array. Use the illustration in Figure 4-6 in conjunction with Table 4-7 to analyze current status for hot-plug hard drives that are connected to an array controller.



**CAUTION:** To avoid data loss, read “Hot-Plug Hard Drive Replacement Guidelines” in the *Servers Troubleshooting Guide* before removing a hard drive.

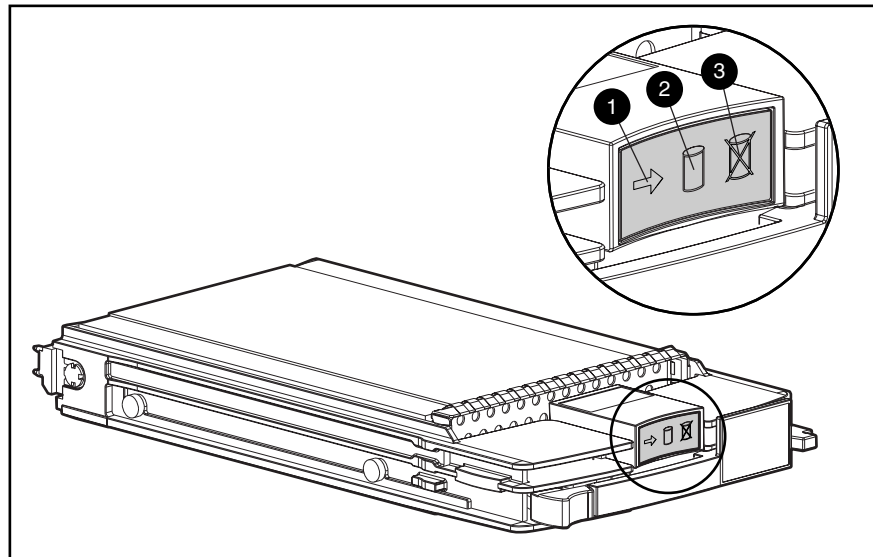

**Figure 4-6: Hot-plug hard drive LEDs**

For additional information on troubleshooting hard drive problems, refer to “Hard Drive Problems” and “SCSI Device Problems” in the *Servers Troubleshooting Guide*.

Table 4-7: Hot-Plug SCSI Hard Drive LED Combinations

Activity	Online	Fault	Meaning
On	Off	Off	<p><b>Do not remove the drive. Removing a drive during this process causes data loss.</b></p> <p>The drive is being accessed and is not configured as part of an array.</p>
On	Flashing	Off	<p><b>Do not remove the drive. Removing a drive during this process causes data loss.</b></p> <p>The drive is rebuilding or undergoing capacity expansion.</p>
Flashing	Flashing	Flashing	<p><b>Do not remove the drive. Removing a drive during this process causes data loss.</b></p> <p>The drive is part of an array being selected by the Array Configuration utility (ACU).</p> <p>-Or-</p> <p>The Options ROMPaq is upgrading the drive.</p>
Off	Off	Off	<p>It is OK to replace the drive online if a predictive failure alert is received (refer to the "Predictive Failure Alert" section in the <i>HP Servers Troubleshooting Guide</i> for details) and the drive is connected to an array controller.</p> <p>The drive is not configured as part of an array.</p> <p>-Or-</p> <p>If this drive is part of an array, a powered-up controller is not accessing the drive.</p> <p>-Or-</p> <p>The drive is configured as an online spare.</p>
Off	Off	On	<p>It is OK to replace the drive online.</p> <p>The drive has failed and has been placed offline.</p>

continued

**Table 4-7: Hot-Plug SCSI Hard Drive LED Combinations** *continued*

<b>Activity</b>	<b>Online</b>	<b>Fault</b>	<b>Meaning</b>
Off	On	Off	<p>OK to replace the drive online if a predictive failure alert is received (refer to the “Predictive Failure Alert” section in the <i>HP Servers Troubleshooting Guide</i> for details), provided that the array is configured for fault tolerance and all other drives in the array are online.</p> <p>The drive is online and is configured as part of an array.</p>
Off	On	Off	<p>OK to replace the drive online if a predictive failure alert is received (refer to the “Predictive Failure Alert” section in the <i>HP Servers Troubleshooting Guide</i> for details), provided that the array is configured for fault tolerance and all other drives in the array are online.</p> <p>The drive is online and is configured as part of an array.</p>
On or flashing	On	Off	<p>OK to replace the drive online if a predictive failure alert is received (refer to the “Predictive Failure Alert” section in the <i>HP Servers Troubleshooting Guide</i> for details), provided that the array is configured for fault tolerance and all other drives in the array are online.</p> <p>The drive is online and is being accessed.</p>

## Network Interface Controller LEDs

The NIC LEDs are located on the back of the server. They provide the following information:

- The speed at which the network is being accessed
- If the server is linked to the network
- If there is current network activity

Refer to the *HP Servers Troubleshooting Guide* for more information on troubleshooting network controller problems.

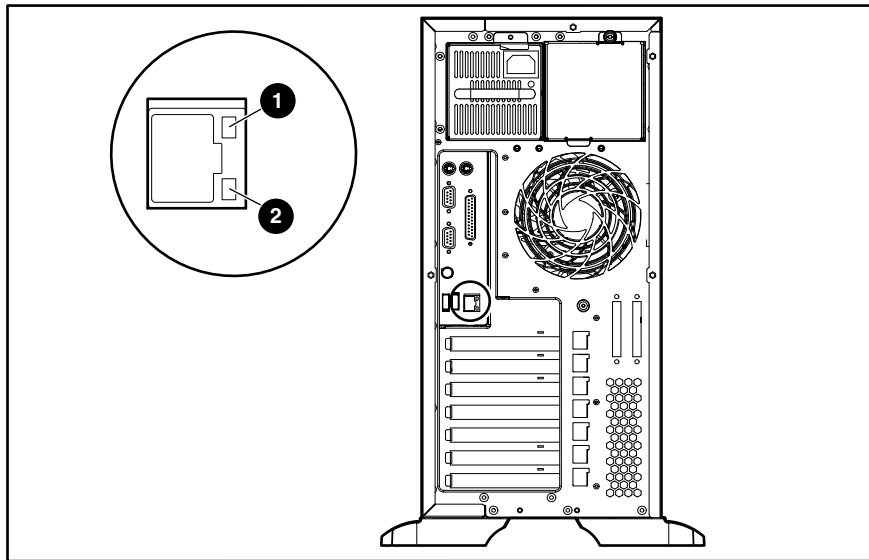

**Figure 4-7: Network Interface Controller (NIC) LEDs**

**Table 4-8: Network Interface Controller LEDs**

Item	Description	Status	Condition
1	Activity	Off	No network activity
		Green blinking	Linked and activity on the network
2	Link	Off	No network link
		Green	Linked to network

---

## Physical and Operating Specifications

This chapter provides physical and operating specifications for the HP ProLiant ML350 Generation 3 server. The following specifications are provided:

- System unit
- Rack server system unit
- Memory
- 1.44-MB Diskette drive
- IDE CD-ROM drive
- Wide Ultra3 SCSI hot-plug hard drives
- Integrated NC7760 gigabit server auto-switching NIC
- Integrated dual channel Wide Ultra3 SCSI adapter
- Remote Insight Lights-Out Edition II option board

## System Unit

**Table 5-1: System Unit Specifications**

Item	Description
Height (without feet)	44.5 cm (17.5 in)
Height (with feet)	46.99 cm (18.5 in)
Depth (without bezel)	60.96 cm (24.0 in)
Depth (with bezel)	66.04 cm (26.0 in)
Width (without feet)	21.59 cm (8.5 in)
Width (with feet)	26.04 cm (10.25 in)
Weight (no drives installed)	27.24 kg (60.0 lb)
Input requirements	International Units (English Units)
Rated input voltage	200 VAC to 240 VAC (100 VAC to 120 VAC)
Rated input frequency	50 Hz to 60 Hz
Rated input current	3.7 A (7.4 A)
Rated input power	538 W
BTUs per hour	1,839
Power supply output	
Rated steady-state power	500 W
Temperature range	
Operating	10°C to 35°C (50°F to 95°F)
Shipping	-40°C to 70°C (-40°F to 158°F)
Relative humidity (noncondensing)	
Operating	10% to 90%
Nonoperating	5% to 95%
Wet-bulb temperature	
Maximum	28°C (82.4°F)
Acoustic noise	
Idle (hard drives spinning)	6.2 NPEL (BELS)/45 AVERAGE SPL (dba)
Operating (random seeks to hard drives)	6.8 NPEL (BELS)/49 AVERAGE SPL (dba)



## Rack Server System Unit

**Table 5-2: Rack Server System Unit Specifications**

<b>Feature</b>	<b>International Units (English Units)</b>
Dimensions	
Height	21.87 cm (8.61 in)
Depth	60.96 cm (24 in)
Width	48.26 cm (19.0 in)
Weight (no drives installed)	27.24 kg (60 lb)
Input requirements	
Rated input voltage	200 VAC to 240 VAC (100 VAC to 120 VAC)
Rated input frequency	50 Hz to 60 Hz
Rated input current	3.7 A (7.4 A)
Rated input power	538 W
BTUs per hour	1,839
Power supply output	
Rated steady-state power	500 W
Temperature range	
Operating	10°C to 35°C (50°F to 95°F)
Shipping	-40°C to 70°C (-40°F to 158°F)
Relative humidity (noncondensing)	
Operating	10% to 90%
Nonoperating	5% to 95%
Wet-bulb temperature	
Maximum	28°C (82.4°F)

## Memory

**Table 5-3: Memory Specifications**

Item	Description
Size	256 MB, 512 MB, 1 GB and 2 GB
Speed	200/266 MHz
Type	PC2100 ECC Registered DDR SDRAM DIMMs
<p><b>Note:</b> DIMMs must be industry-standard 184-pin PC2100 DDR DIMMs. The DDR DIMMs must support CAS Latency 2 or greater. They must also contain the mandatory Joint Electronic Device Engineering Council (JEDEC) Serial Presence Detect (SPD).</p>	

## 1.44-MB Diskette Drive

**Table 5-4: 1.44-M Diskette Drive Specifications**

Item	Description
Size	88.9 mm (3.5 in)
LED (front panel)	Green
Read/write capacity per diskette (high/low density)	1.44 MB/720 KB
Drives supported	1
Drive height	15.2 mm (0.6 inch)
Drive rotation	300 rpm
Transfer rate bits/sec (high/low)	500/250 Kbps
Bytes/sector	512
Sectors/track (high/low)	18/9
Tracks/side (high/low)	80/80
Access times	
Track-to-track (high/low)	6 ms/3 ms
Average (high/low)	174 ms/94 ms
Settling time	15 ms
Latency average	100 ms
Cylinders (high/low)	80/80
Read/write heads	2

## IDE CD-ROM Drive

**Table 5-5: IDE CD-ROM Drive Specifications**

Item	Description
Capacity	540 MB (mode 1, 12 cm) 650 MB (mode 2, 12 cm)
Block size	2,048 bytes (mode 1); 2,340; 2336 bytes (mode 2); 2,352 bytes (CD-DA); 2,328 (CD-XA)
Dimensions	
Height	12.7 mm (0.5 in)
Width	130 mm (5.11 in)
Depth	131 mm (5.16 in)
Weight	<1,200 g (<42.4 oz)
Data transfer rate	
Sustained	150 KBps (sustained 1X)
Burst	2,500 KBps to 6,000 KBps
Bus rate	48 MBps
Access times (typical)	
Full stroke	<100 ms
Random	<150 ms
Disk diameter	12 cm, 8 cm (4.7 in, 3.15 in)
Disk thickness	1.2 mm, 0.05 cm (0.047 in x 0.20 in)
Track pitch	1.6 $\mu$ m
Cache/buffer	128 KB
Startup time	<7s (single session); <30s (multisession)
Stop time	<4s
Operating conditions	
Temperature	5°C to 45°C (41°F to 110°F)
Humidity	10% to 80%

## Wide Ultra3 SCSI Hot-Plug Hard Drives

**Table 5-6: Wide Ultra3 SCSI Hard Drive Specifications**

Item	9-GB Drive	18-GB Drive	36-GB Drive	72-GB Drive
Capacity	9100.0 MB	18,209.8 MB	36,419.6 MB	72,839.2 MB
Height	One-third, 1.0 in	One-third, 1.0 in	One-third, 1.0 in	One-third, 1.0 in
Size	3.5 in	3.5 in	3.5 in	3.5 in
Interface	Wide Ultra3	Wide Ultra3	Wide Ultra3	Wide Ultra3
Transfer Rate	160 MBps	160 MBps	160 MBps	160 MBps
Rotational Speed	10,000 RPM	10,000 RPM	10,000 RPM	10,000 RPM
Bytes per sector	512	512	512	512
Logical Blocks	17,773,524	35,566,080	71,132,000	142,264,000
Operating Temperature	10°C to 35°C (50°F to 95°F)	10°C to 35°C (50°F to 95°F)	10°C to 35°C (50°F to 95°F)	10°C to 35°C (50°F to 95°F)

## Integrated NC7760 Gigabit Server Auto-switching NIC

**Table 5-7: Integrated NC7760 Gigabit Server Auto-switching NIC Specifications**

Item	Description
Network interface	10Base-T/100Base-TX/1000Base-T Ethernet
Compatibility	IEEE 802.2, 802.3, 803.3u
Data transfer method	32-bit, PC 33-MHz bus master
Network transfer rate	10/100/1000 Mbps
Connector	RJ-45
I/O address and interrupt	Plug and Play PCI

## Integrated Dual Channel Wide Ultra3 SCSI Adapter

**Table 5-8: Integrated Dual Channel Wide Ultra3 SCSI Adapter Specifications**

Item	Description
Protocol	Wide Ultra160 SCSI, Wide Ultra3 SCSI, Wide Ultra SCSI, Fast-Wide SCSI-2, and Fast SCSI-2
Compatibility	All PCI server configurations are backward compatible with Fast, Fast-Wide SCSI-2, Wide Ultra2 SCSI, and Wide Ultra3 SCSI devices
Drives supported	Up to 15 SCSI devices per channel
Data transfer method	32-bit PCI bus master
Maximum transfer rate per PCI bus	133 MBps
SCSI channel transfer rate	160 MBps
SCSI termination	Active termination
SCSI connectors	2 internal (68-pin)
Capacity	509.6 GB
Height	1.0 in
Size	3.5 in
Interface	Wide Ultra3 SCSI
Seek time	
Single track	0.8 ms
Average	7.9 ms
Full stroke	17.0 ms
Rotational speed	7,200 rpm
Physical configuration	
Bytes/sector	512
Logical blocks	17,773,524
Operating temperature	10°C to 35°C (50°F to 95°F)

## Remote Insight Lights-Out Edition II Option Board

**Table 5-9: Remote Insight Lights-out Edition II Option Board Specifications**

Item	Description
Architecture	32-bit PCI-based remote management board (For the ProLiant ML350 Generation 3 server, install the board in the 32-bit PCI slot.)
Processor	IBM 405 GP 200 Mhz (Power PC)
Memory	32-MB SDRAM, 4-MB Flash ROM
Upgradability	Option firmware upgradable using flash ROM
Video support	ATI Rage XL, supporting modes: <ul style="list-style-type: none"><li>• 640 x 480 (256 to 16.7 M colors)</li><li>• 800 x 600 (256 to 16.7 M colors)</li><li>• 1,024 x 768 (256 to 65 K colors)</li><li>• 1,280 x 1,024 (256 colors)</li></ul>
Connectors	External power, keyboard/mouse, video, Ethernet network connection (10/100 Mbps)
External power adapter	10 VDC, 1.5 A
Remote Insight operating system support	Go to <a href="http://www.hp.com/servers/lights-out">www.hp.com/servers/lights-out</a>
Remote Insight client browser support	Microsoft Internet Explorer 5.0, Netscape Navigator 6.01, or any other Java™ 1.1-compliant browser software

## A

- AC power, caution 4-10
- access panel
  - part number 1-3
  - removing 2-7
  - replacing 2-7
- ADU (Array Diagnostics Utility) 3-4
- air baffle
  - part number 1-3
  - removing 2-15
  - replacing 2-15
- Array Diagnostics Utility *See* ADU
- ASR (Automatic Server Recovery), running 3-3

## B

- battery
  - handling, warning 2-39
  - part number 1-5
  - system board 2-39
  - system board, location 2-40
  - system board, replacing 2-40
- bezel (rack)
  - part number 1-3
  - removing 2-8
  - removing, illustrated 2-10
  - replacing 2-10
- bezel door (tower)
  - part number 1-3
  - removing 2-6
  - replacing 2-6
- boards, part number 1-5

## C

- cable routing
  - caution 2-12
  - diagrams 2-12
- cautions
  - AC power 4-10
  - cable routing 2-12
  - ESD 2-4, 2-31, 2-33, 2-39
  - handling components 2-30

- handling memory modules 2-30
- hot-plug hard drive replacement 4-13
- power fluctuations 2-4
- processor locking lever 2-35
- proper cooling 2-4
- removing access panel 2-30
- CMOS, clearing 4-6
- component-level repairs *vii*
  - warnings 2-4
- connectors, overview 4-2
- cooling, caution 2-4
- country kit, part number 1-6
- cover kit
  - contents 1-3
  - part number 1-3
- CPU fan module
  - part number 1-5
  - removing 2-16
  - status LED 4-12

## D

- diagnostics overview 3-1
- Diagnostics Utility
  - accessing 3-1
  - locating 3-1
- diskette drive
  - access times 5-4
  - dimensions 5-4
  - part number 1-5
- diskette drive cable assembly, part number 1-6
- drive bay configuration, illustrated 2-19
- drivers, installing 3-4
- dual channel Wide Ultra3 SCSI adapter, capacity 5-7

## E

- electric shock
  - symbol 2-3
  - warning 2-3
- electrostatic discharge *See* ESD
- ESD (electrostatic discharge)
  - caution 2-4, 2-33
  - packaging 2-2
  - preventing 2-2

- sensitive parts 2-2
  - storing 2-2
  - tools recommended 2-2
  - transporting 2-2
  - work area recommendations 2-2
- event log
- described 3-4
  - viewing 3-4
- expansion board
- removing 2-28
  - replacing 2-29
- expansion board guide, part number 1-3
- expansion board retainer
- part number 1-3
  - removing, illustrated 2-28
- exploded view, mechanical parts 1-2
- ## F
- fan *See* system fan module
- feet
- part number 1-3
  - removing 2-43
  - replacing 2-43
- front faceplate and bezel (rack), part number 1-3
- ## G
- grounding viii
- techniques 2-2
- grounding plug viii
- ## H
- hard drive LEDs
- activity 4-14, 4-15
  - fault 4-14, 4-15
  - online 4-14, 4-15
- hazard symbol 2-3
- hazardous conditions *See* symbols on equipment
- hazardous energy circuits symbol 2-3
- help resources ix
- hood panel, part number 1-3
- hot surface
- symbol 2-3
  - warning 2-3
- hot surface, warning 2-4, 2-36
- hot-plug hard drive
- LEDs, illustrated 4-13
  - removing 2-21
  - replacing 2-21
  - replacing, caution 4-13
- hot-plug hard drive blank
- part number 1-3
  - removing 2-20
  - replacing 2-20
- hot-plug hard drive cage
- part number 1-3, 1-5
  - removing 2-22
  - replacing 2-23
- HP authorized reseller ix
- HP Insight Manager 3-1
- ## I
- I/O fan module
- part number 1-5
  - removing 2-18
  - status LED 4-12
- ID switch
- location 4-4
  - settings 4-5
- IDE CD-ROM drive
- access times 5-5
  - block size 5-5
  - capacity 5-5
  - dimensions 5-5
  - operating conditions 5-5
  - part number 1-5
  - signal cable routing, illustrated 2-13
  - transfer rate 5-5
  - weight 5-5
- IDE ribbon cable assembly, part number 1-6
- IML (Integrated Management Log), described 3-4
- indicators *See* LEDs
- INSPECT
- accessing 3-4
  - described 3-4
- IRQ conflict, resolving 3-3
- ## J
- jumper settings, obtaining 3-3
- ## K
- keyboard, part number 1-6
- kits
- country, part number 1-6
  - cover, part number 1-3
  - miscellaneous plastics, part number 1-3
  - return (rack), part number 1-6
  - return (tower), part number 1-6
  - signal cable, part number 1-6
  - tower-to-rack conversion, part number 1-6
- ## L
- labels *See* symbols on equipment
- LEDs
- CPU fan status 4-12
  - DIMM status 4-12



- external health 4-9
- hard drive , table of combinations 4-14, 4-15
- hard drive activity, defined 4-14, 4-15
- hard drive fault 4-14, 4-15
- hard drive online 4-14, 4-15
- hot-plug hard drive, illustrated 4-13
- I/O fan status 4-12
- internal health 4-9
- network activity 4-16
- network link 4-16
- network speed, illustrated 4-16
- NIC (Network Interface Connector) 4-10
- NIC, illustrated 4-16
- NIC, summary 4-16
- overview 4-7
- Power On/Standby 4-10
- power supply 4-11
- PPM 1 status 4-11
- PPM 2 status 4-12
- processor 1 status 4-11
- processor 1 thermal 4-11
- processor 2 status 4-12
- processor 2 thermal 4-12
- system board 4-11
- system status 4-8
- temperature threshold 4-12
- unit identification (UID) 4-9

## M

- mass storage devices, part number 1-5
- mechanical parts
  - illustrated 1-2
  - spare parts list 1-3
- media device blank
  - removing 2-11
  - replacing 2-11
- memory modules
  - installation guidelines 2-30
  - part number 1-5
  - removing 2-31
  - replacing 2-31
  - size 5-4
  - socket locations, illustrated 2-30
  - speed 5-4
- miscellaneous plastics kit, part number 1-3
- miscellaneous, part numbers 1-6

## N

- NIC (network interface controller)
  - activity LED 4-16
  - LEDs, illustrated 4-16
  - LEDs, summary 4-16
  - link LED 4-16
- NVRAM (nonvolatile RAM), clearing 4-6

## O

- options, part numbers 1-5

## P

- part numbers
  - access panel 1-3
  - air baffle 1-3
  - battery 1-5
  - bezel door (tower) 1-3
  - boards 1-5
  - country kit 1-6
  - cover kit 1-3
  - CPU fan module 1-5
  - diskette drive 1-5
  - diskette drive cable assembly 1-6
  - expansion board guide 1-3
  - expansion board retainer 1-3
  - feet 1-3
  - front faceplate and bezel (rack) 1-3
  - hood panel 1-3
  - hot-plug drive blank 1-3
  - hot-plug hard drive cage 1-3, 1-5
  - I/O fan module 1-5
  - IDE CD-ROM drive 1-5
  - IDE ribbon cable assembly 1-6
  - keyboard 1-6
  - mass storage devices 1-5
  - memory modules 1-5
  - miscellaneous 1-6
  - miscellaneous plastics kit 1-3
  - options 1-5
  - power 1-5
  - power supply backplane board 1-5
  - power supply backplane board cover 1-3
  - power supply blank 1-3
  - power supply with power factor correction 1-5
  - power switch assembly 1-5
  - PPM 1-5
  - processor 1-5
  - rackmount hardware kit with rails 1-3
  - removable media device blank 1-3
  - removable media device, SCSI cable 1-6
  - retainer clips 1-3
  - return kit (rack) 1-6
  - return kit (tower) 1-6
  - SCSI Point-to Point cable 1-6
  - signal cable kit 1-6
  - system board 1-5
  - top panel 1-3
  - tower-to-rack conversion kit 1-6
- parts
  - catalog, illustrated 1-1
  - handling 2-2
  - storing 2-2

- transporting 2-2
- PCI boards, configuring automatically 3-3
- personal injury, warning 2-4
- POST
  - described 3-3
  - running 3-3
- power button
  - location 4-10
  - positions 2-4
  - summary 4-8
- power cords, disconnecting, warning 2-4
- power fluctuations, caution 2-4
- Power On/Standby status, LED 4-10
- power sources symbol 2-3
- power supply
  - blank, part number 1-3
  - LED 4-11
  - removing 2-41
  - replacing 2-41
- power supply backplane board
  - part number 1-5
  - removing 2-42
  - replacing 2-42
- power supply backplane board cover, part number 1-3
- power supply with power factor correction, part number 1-5
- power switch assembly, part number 1-5
- power warning 2-3
- power, part number 1-5
- power-down procedures 2-4
- Power-On Self-Test *See* POST
- PPM (Processor Power Module)
  - part number 1-5
  - Processor Power Module 1, LEDs 4-11
  - Processor Power Module 2, LEDs 4-12
  - removing 2-36
  - replacing 2-36
  - socket locations, illustrated 2-32
  - warning 2-36
- processor
  - caution 2-35
  - part number 1-5
  - removing 2-33
  - replacing 2-35
  - socket locations, illustrated 2-32
- processor 1
  - LEDs, status 4-11
  - LEDs, thermal 4-11
- processor 2
  - LEDs, status 4-12
  - LEDs, thermal 4-12
- Processor Power Module *See* PPM

## R

- rack server system unit
  - dimensions 5-3
  - input voltage requirements 5-3
  - power supply output 5-3
  - relative humidity 5-3
  - temperature range 5-3
  - wet-bulb temperature 5-3
- rack stability, warning 2-5
- rackmount hardware kit with rails, part number 1-3
- RBSU (ROM-Based Setup Utility)
  - description 3-3
  - running 3-3
- rear panel components 4-2
- removable media device
  - removing 2-24
  - SCSI cable, part number 1-6
  - signal cable routing, illustrated 2-13
- removable media device blank, part number 1-3
- removal and replacement procedures 2-1
- resource conflict, resolving 3-3
- retainer clips, part number 1-3
- return kit (rack), part number 1-6
- return kit (tower), part number 1-6
- RJ-45 receptacle symbol 2-3
- RJ-45 receptacle, warning 2-3
- ROM-Based Setup Utility *See* RBSU
- ROMPaq Utility, running 3-2

## S

- screwdriver symbol 2-3
- SCSI LVD hard drive
  - Point-to-Point cable routing 2-14
  - Point-to-Point cable, part number 1-6
  - specifications 5-6
- signal cable kit, part number 1-6
- SmartStart Diskette Builder
  - description 3-2
  - running 3-2
- SmartStart software 3-2
- specifications
  - IDE CD-ROM Drive 5-5
  - NIC 5-6
  - physical and operating, overview 5-1
  - Remote Insight Lights-out Edition board 5-8
  - SCSI LVD hard drive 5-6
  - Ultra3 SCSI Adapter 5-7
- standby
  - activating 2-5
  - effects 2-4
- Survey Utility
  - description 3-2
  - installing 3-2
- switch settings, obtaining 3-3

- symbols
    - on equipment 2-3
  - system board
    - components 4-3
    - configuration switch settings 4-5
    - ID switch settings 4-5
    - LEDs 4-11
    - part number 1-5
    - removing 2-37
    - replacing 2-38
    - switches 4-4
  - system components
    - exploded view 1-4
    - illustrated 1-4
    - spare parts list 1-5, 1-6
  - system configuration switch
    - CMOS, clearing 4-6
    - location 4-4
    - NVRAM, clearing 4-6
    - settings 4-5
  - system fan modules, connector locations 2-16
  - System Firmware Update 3-3
  - system status LEDs
    - location 4-9
    - summary 4-8
  - system unit
    - acoustic noise 5-2
    - input voltage requirements 5-2
    - power supply output 5-2
    - relative humidity 5-2
    - temperature range 5-2
    - wet-bulb temperature 5-2
- T**
- technician notes vii
  - telephone numbers ix
  - telephone symbol 2-3
  - temperature threshold LED 4-12
  - tools recommended for servicing 2-1
  - top panel, part number 1-3
  - tower-to-rack conversion kit, part number 1-6
- U**
- unit identification button (UID)
    - described 4-9
  - summary 4-8
- utilities**
- ADU (Array Diagnostics Utility) 3-4
  - ASR (Automatic Server Recovery) 3-3
  - Diagnostics 3-1
  - HP Insight Manager 3-1
  - IML 3-4
  - INSPECT 3-4
  - INSPECT, accessing 3-4
  - overview 3-1
  - POST 3-3
  - RBSU (ROM-Based Setup Utility) 3-3
  - ROMPaq 3-2
  - SmartStart Diskette Builder 3-2
  - SmartStart, described 3-2
  - Survey Utility 3-2
- V**
- ventilation clearances viii
- W**
- warnings**
- battery handling 2-39
  - component-level repairs 2-4
  - disconnecting power cords 2-4
  - electric shock 2-3
  - heavy weight 2-3
  - hot surface 2-3, 2-4, 2-36
  - improper repairs 2-4
  - multiple sources of power 2-3
  - personal injury 2-4
  - rack stability 2-5
  - RJ-45 receptacle 2-3
  - technician notes 2-4
- warranty** viii
- weight**
- symbol 2-3
  - warning 2-3
- Wide Ultra3 SCSI hard drive**
- operating temperature 5-7
  - physical configuration 5-7
  - seek time 5-7
- work area recommendations** 2-2
- wrist strap, using** 2-2