



**Hewlett Packard**  
Enterprise

# **HPE ProLiant SL270s Gen8 SE Server**

## Maintenance and Service Guide

### Abstract

This guide is for an experienced service technician. Hewlett Packard Enterprise assumes you are qualified in the servicing of computer equipment and trained in recognizing hazards in products with hazardous energy levels and are familiar with weight and stability precautions for rack installations.

Part Number: 743909-001R  
December 2015  
Edition: 2

© Copyright 2013, 2015 Hewlett Packard Enterprise Development LP

The information contained herein is subject to change without notice. The only warranties for Hewlett Packard Enterprise products and services are set forth in the express warranty statements accompanying such products and services. Nothing herein should be construed as constituting an additional warranty. Hewlett Packard Enterprise shall not be liable for technical or editorial errors or omissions contained herein.

Microsoft®, Windows®, and Windows Server® are either registered trademarks or trademarks of Microsoft Corporation in the United States and/or other countries. Intel® Xeon® is a trademark of Intel Corporation in the U.S. and other countries.

# Contents

Customer self repair .....	5
Parts only warranty service .....	5
Illustrated parts catalog .....	15
Mechanical components .....	15
System components .....	18
Removal and replacement procedures .....	24
Required tools .....	24
Safety considerations .....	24
Preventing electrostatic discharge .....	24
Symbols on equipment .....	24
Server warnings and cautions .....	25
Preparation procedures .....	25
Power up the server .....	25
Power down the server .....	26
Remove the server from the chassis .....	26
Remove the hot-plug SFF drive cage .....	27
Remove the shipping brackets and shipping plates .....	27
Remove the PCI/FlexibleLOM riser cage .....	28
Remove the GPU cage .....	29
Drive blank .....	31
Hot-plug drive .....	32
Hot-plug drive cage backplane .....	33
x32 riser board .....	34
System battery .....	35
Flash-backed write cache procedures .....	36
FBWC capacitor pack .....	36
FBWC capacitor pack holder .....	37
PCIe/FlexibleLOM riser board .....	38
GPU module or blank .....	39
Expansion boards .....	40
Mezzanine board .....	41
DIMMs .....	42
Processor air baffle .....	43
Heatsink .....	43
Processor .....	45
System board .....	49
Re-entering the server serial number and product ID .....	55
Personality board .....	56
L2 power board .....	57
HP Trusted Platform Module .....	57
Diagnostic tools .....	58
Troubleshooting resources .....	58
HPE ROM-Based Setup Utility .....	58
HPE Insight Diagnostics .....	59
Integrated Management Log .....	59
Component identification .....	60
Front panel components .....	60
Front panel LEDs and buttons .....	61
Rear panel components .....	62
Rear panel LEDs and buttons .....	62
System board components .....	63

DIMM slot locations .....	64
System maintenance switch .....	65
NMI functionality .....	65
Drive numbering .....	66
GPU numbering .....	66
Hot-plug drive LED definitions .....	67
Cabling .....	68
Cabling overview .....	68
Personality board cabling .....	68
FBWC capacitor pack cabling .....	69
Front drive cage cabling .....	71
GPU cabling .....	72
Specifications .....	74
Environmental specifications .....	74
Server specifications .....	74
Hot-plug power supply calculations .....	74
Acronyms and abbreviations .....	75
Documentation feedback .....	77
Index .....	78

# Customer self repair

Hewlett Packard Enterprise products are designed with many Customer Self Repair (CSR) parts to minimize repair time and allow for greater flexibility in performing defective parts replacement. If during the diagnosis period Hewlett Packard Enterprise (or Hewlett Packard Enterprise service providers or service partners) identifies that the repair can be accomplished by the use of a CSR part, Hewlett Packard Enterprise will ship that part directly to you for replacement. There are two categories of CSR parts:

- **Mandatory**—Parts for which customer self repair is mandatory. If you request Hewlett Packard Enterprise to replace these parts, you will be charged for the travel and labor costs of this service.
- **Optional**—Parts for which customer self repair is optional. These parts are also designed for customer self repair. If, however, you require that Hewlett Packard Enterprise replace them for you, there may or may not be additional charges, depending on the type of warranty service designated for your product.

**NOTE:** Some Hewlett Packard Enterprise parts are not designed for customer self repair. In order to satisfy the customer warranty, Hewlett Packard Enterprise requires that an authorized service provider replace the part. These parts are identified as "No" in the Illustrated Parts Catalog.

Based on availability and where geography permits, CSR parts will be shipped for next business day delivery. Same day or four-hour delivery may be offered at an additional charge where geography permits. If assistance is required, you can call the Hewlett Packard Enterprise Support Center and a technician will help you over the telephone. Hewlett Packard Enterprise specifies in the materials shipped with a replacement CSR part whether a defective part must be returned to Hewlett Packard Enterprise. In cases where it is required to return the defective part to Hewlett Packard Enterprise, you must ship the defective part back to Hewlett Packard Enterprise within a defined period of time, normally five (5) business days. The defective part must be returned with the associated documentation in the provided shipping material. Failure to return the defective part may result in Hewlett Packard Enterprise billing you for the replacement. With a customer self repair, Hewlett Packard Enterprise will pay all shipping and part return costs and determine the courier/carrier to be used.

For more information about the Hewlett Packard Enterprise CSR program, contact your local service provider. For the North American program, go to the Hewlett Packard Enterprise CSR website (<http://www.hpe.com/support/selfrepair>).

## Parts only warranty service

Your Hewlett Packard Enterprise Limited Warranty may include a parts only warranty service. Under the terms of parts only warranty service, Hewlett Packard Enterprise will provide replacement parts free of charge.

For parts only warranty service, CSR part replacement is mandatory. If you request Hewlett Packard Enterprise to replace these parts, you will be charged for the travel and labor costs of this service.

## Réparation par le client (CSR)

Les produits Hewlett Packard Enterprise comportent de nombreuses pièces CSR (Customer Self Repair = réparation par le client) afin de minimiser les délais de réparation et faciliter le remplacement des pièces défectueuses. Si pendant la période de diagnostic, Hewlett Packard Enterprise (ou ses partenaires ou mainteneurs agréés) détermine que la réparation peut être effectuée à l'aide d'une pièce CSR, Hewlett Packard Enterprise vous l'envoie directement. Il existe deux catégories de pièces CSR :

- **Obligatoire**—Pièces pour lesquelles la réparation par le client est obligatoire. Si vous demandez à Hewlett Packard Enterprise de remplacer ces pièces, les coûts de déplacement et main d'œuvre du service vous seront facturés.
- **Facultatif**—Pièces pour lesquelles la réparation par le client est facultative. Ces pièces sont également conçues pour permettre au client d'effectuer lui-même la réparation. Toutefois, si vous demandez à Hewlett Packard Enterprise de remplacer ces pièces, l'intervention peut ou non vous être facturée, selon le type de garantie applicable à votre produit.

**REMARQUE:** Certaines pièces Hewlett Packard Enterprise ne sont pas conçues pour permettre au client d'effectuer lui-même la réparation. Pour que la garantie puisse s'appliquer, Hewlett Packard Enterprise exige que le remplacement de la pièce soit effectué par un Mainteneur Agréé. Ces pièces sont identifiées par la mention "Non" dans le Catalogue illustré.

Les pièces CSR sont livrées le jour ouvré suivant, dans la limite des stocks disponibles et selon votre situation géographique. Si votre situation géographique le permet et que vous demandez une livraison le jour même ou dans les 4 heures, celle-ci vous sera facturée. Pour toute assistance, appelez le Centre d'assistance Hewlett Packard Enterprise pour qu'un technicien vous aide au téléphone. Dans les documents envoyés avec la pièce de rechange CSR, Hewlett Packard Enterprise précise s'il est nécessaire de lui retourner la pièce défectueuse. Si c'est le cas, vous devez le faire dans le délai indiqué, généralement cinq (5) jours ouvrés. La pièce et sa documentation doivent être retournées dans l'emballage fourni. Si vous ne retournez pas la pièce défectueuse, Hewlett Packard Enterprise se réserve le droit de vous facturer les coûts de remplacement. Dans le cas d'une pièce CSR, Hewlett Packard Enterprise supporte l'ensemble des frais d'expédition et de retour, et détermine la société de courses ou le transporteur à utiliser.

Pour plus d'informations sur le programme CSR de Hewlett Packard Enterprise, contactez votre Mainteneur Agréé local. Pour plus d'informations sur ce programme en Amérique du Nord, consultez le site Web Hewlett Packard Enterprise (<http://www.hpe.com/support/selfrepair>).

## Service de garantie "pièces seules"

Votre garantie limitée Hewlett Packard Enterprise peut inclure un service de garantie "pièces seules". Dans ce cas, les pièces de rechange fournies par Hewlett Packard Enterprise ne sont pas facturées.

Dans le cadre de ce service, la réparation des pièces CSR par le client est obligatoire. Si vous demandez à Hewlett Packard Enterprise de remplacer ces pièces, les coûts de déplacement et main d'œuvre du service vous seront facturés.

## Riparazione da parte del cliente

Per abbreviare i tempi di riparazione e garantire una maggiore flessibilità nella sostituzione di parti difettose, i prodotti Hewlett Packard Enterprise sono realizzati con numerosi componenti che possono essere riparati direttamente dal cliente (CSR, Customer Self Repair). Se in fase di diagnostica Hewlett Packard Enterprise (o un centro di servizi o di assistenza Hewlett Packard Enterprise) identifica il guasto come riparabile mediante un ricambio CSR, Hewlett Packard Enterprise lo spedisce direttamente al cliente per la sostituzione. Vi sono due categorie di parti CSR:

- **Obbligatorie**—Parti che devono essere necessariamente riparate dal cliente. Se il cliente ne affida la riparazione ad Hewlett Packard Enterprise, deve sostenere le spese di spedizione e di manodopera per il servizio.
- **Opzionali**—Parti la cui riparazione da parte del cliente è facoltativa. Si tratta comunque di componenti progettati per questo scopo. Se tuttavia il cliente ne richiede la sostituzione ad Hewlett Packard Enterprise, potrebbe dover sostenere spese aggiuntive a seconda del tipo di garanzia previsto per il prodotto.

**NOTA:** alcuni componenti Hewlett Packard Enterprise non sono progettati per la riparazione da parte del cliente. Per rispettare la garanzia, Hewlett Packard Enterprise richiede che queste parti siano sostituite da un centro di assistenza autorizzato. Tali parti sono identificate da un "No" nel Catalogo illustrato dei componenti.

In base alla disponibilità e alla località geografica, le parti CSR vengono spedite con consegna entro il giorno lavorativo seguente. La consegna nel giorno stesso o entro quattro ore è offerta con un supplemento di costo solo in alcune zone. In caso di necessità si può richiedere l'assistenza telefonica di un addetto del centro di supporto tecnico Hewlett Packard Enterprise. Nel materiale fornito con una parte di ricambio CSR, Hewlett Packard Enterprise specifica se il cliente deve restituire dei componenti. Qualora sia richiesta la resa ad Hewlett Packard Enterprise del componente difettoso, lo si deve spedire ad Hewlett Packard Enterprise entro un determinato periodo di tempo, generalmente cinque (5) giorni lavorativi. Il componente difettoso deve essere restituito con la documentazione associata nell'imballo di spedizione fornito. La mancata restituzione del componente può comportare la fatturazione del ricambio da parte di Hewlett Packard Enterprise. Nel caso di riparazione da parte del cliente, Hewlett Packard Enterprise sostiene tutte le spese di spedizione e resa e sceglie il corriere/vettore da utilizzare.

Per ulteriori informazioni sul programma CSR di Hewlett Packard Enterprise, contattare il centro di assistenza di zona. Per il programma in Nord America fare riferimento al sito Web (<http://www.hpe.com/support/selfrepair>).

## Servizio di garanzia per i soli componenti

La garanzia limitata Hewlett Packard Enterprise può includere un servizio di garanzia per i soli componenti. Nei termini di garanzia del servizio per i soli componenti, Hewlett Packard Enterprise fornirà gratuitamente le parti di ricambio.

Per il servizio di garanzia per i soli componenti è obbligatoria la formula CSR che prevede la riparazione da parte del cliente. Se il cliente invece richiede la sostituzione ad Hewlett Packard Enterprise dovrà sostenere le spese di spedizione e di manodopera per il servizio.

## Customer Self Repair

Hewlett Packard Enterprise Produkte enthalten viele CSR-Teile (Customer Self Repair), um Reparaturzeiten zu minimieren und höhere Flexibilität beim Austausch defekter Bauteile zu ermöglichen. Wenn Hewlett Packard Enterprise (oder ein Hewlett Packard Enterprise Servicepartner) bei der Diagnose feststellt, dass das Produkt mithilfe eines CSR-Teils repariert werden kann, sendet Ihnen Hewlett Packard Enterprise dieses Bauteil zum Austausch direkt zu. CSR-Teile werden in zwei Kategorien unterteilt:

- **Zwingend**—Teile, für die das Customer Self Repair-Verfahren zwingend vorgegeben ist. Wenn Sie den Austausch dieser Teile von Hewlett Packard Enterprise vornehmen lassen, werden Ihnen die Anfahrt- und Arbeitskosten für diesen Service berechnet.
- **Optional**—Teile, für die das Customer Self Repair-Verfahren optional ist. Diese Teile sind auch für Customer Self Repair ausgelegt. Wenn Sie jedoch den Austausch dieser Teile von Hewlett Packard Enterprise vornehmen lassen möchten, können bei diesem Service je nach den für Ihr Produkt vorgesehenen Garantiebedingungen zusätzliche Kosten anfallen.

**HINWEIS:** Einige Hewlett Packard Enterprise Teile sind nicht für Customer Self Repair ausgelegt. Um den Garantieanspruch des Kunden zu erfüllen, muss das Teil von einem Hewlett Packard Enterprise Servicepartner ersetzt werden. Im illustrierten Teilekatalog sind diese Teile mit „No“ bzw. „Nein“ gekennzeichnet.

CSR-Teile werden abhängig von der Verfügbarkeit und vom Lieferziel am folgenden Geschäftstag geliefert. Für bestimmte Standorte ist eine Lieferung am selben Tag oder innerhalb von vier Stunden gegen einen Aufpreis verfügbar. Wenn Sie Hilfe benötigen, können Sie das Hewlett Packard Enterprise

Support Center anrufen und sich von einem Mitarbeiter per Telefon helfen lassen. Den Materialien von Hewlett Packard Enterprise, die mit einem CSR-Ersatzteil geliefert werden, können Sie entnehmen, ob das defekte Teil an Hewlett Packard Enterprise zurückgeschickt werden muss. Wenn es erforderlich ist, das defekte Teil an Hewlett Packard Enterprise zurückzuschicken, müssen Sie dies innerhalb eines vorgegebenen Zeitraums tun, in der Regel innerhalb von fünf (5) Geschäftstagen. Das defekte Teil muss mit der zugehörigen Dokumentation in der Verpackung zurückgeschickt werden, die im Lieferumfang enthalten ist. Wenn Sie das defekte Teil nicht zurückschicken, kann Hewlett Packard Enterprise Ihnen das Ersatzteil in Rechnung stellen. Im Falle von Customer Self Repair kommt Hewlett Packard Enterprise für alle Kosten für die Lieferung und Rücksendung auf und bestimmt den Kurier-/Frachtdienst.

Weitere Informationen über das Hewlett Packard Enterprise Customer Self Repair Programm erhalten Sie von Ihrem Servicepartner vor Ort. Informationen über das CSR-Programm in Nordamerika finden Sie auf der Hewlett Packard Enterprise Website unter (<http://www.hpe.com/support/selfrepair>).

## Parts-only Warranty Service (Garantieservice ausschließlich für Teile)

Ihre Hewlett Packard Enterprise Garantie umfasst möglicherweise einen Parts-only Warranty Service (Garantieservice ausschließlich für Teile). Gemäß den Bestimmungen des Parts-only Warranty Service stellt Hewlett Packard Enterprise Ersatzteile kostenlos zur Verfügung.

Für den Parts-only Warranty Service ist das CSR-Verfahren zwingend vorgegeben. Wenn Sie den Austausch dieser Teile von Hewlett Packard Enterprise vornehmen lassen, werden Ihnen die Anfahrt- und Arbeitskosten für diesen Service berechnet.

## Reparaciones del propio cliente

Los productos de Hewlett Packard Enterprise incluyen muchos componentes que el propio usuario puede reemplazar (Customer Self Repair, CSR) para minimizar el tiempo de reparación y ofrecer una mayor flexibilidad a la hora de realizar sustituciones de componentes defectuosos. Si, durante la fase de diagnóstico, Hewlett Packard Enterprise (o los proveedores o socios de servicio de Hewlett Packard Enterprise) identifica que una reparación puede llevarse a cabo mediante el uso de un componente CSR, Hewlett Packard Enterprise le enviará dicho componente directamente para que realice su sustitución. Los componentes CSR se clasifican en dos categorías:

- **Obligatorio**—Componentes cuya reparación por parte del usuario es obligatoria. Si solicita a Hewlett Packard Enterprise que realice la sustitución de estos componentes, tendrá que hacerse cargo de los gastos de desplazamiento y de mano de obra de dicho servicio.
- **Opcional**—Componentes cuya reparación por parte del usuario es opcional. Estos componentes también están diseñados para que puedan ser reparados por el usuario. Sin embargo, si precisa que Hewlett Packard Enterprise realice su sustitución, puede o no conllevar costes adicionales, dependiendo del tipo de servicio de garantía correspondiente al producto.

**NOTA:** Algunos componentes de Hewlett Packard Enterprise no están diseñados para que puedan ser reparados por el usuario. Para que el usuario haga valer su garantía, Hewlett Packard Enterprise pone como condición que un proveedor de servicios autorizado realice la sustitución de estos componentes. Dichos componentes se identifican con la palabra "No" en el catálogo ilustrado de componentes.

Según la disponibilidad y la situación geográfica, los componentes CSR se enviarán para que lleguen a su destino al siguiente día laborable. Si la situación geográfica lo permite, se puede solicitar la entrega en el mismo día o en cuatro horas con un coste adicional. Si precisa asistencia técnica, puede llamar al Centro de asistencia técnica de Hewlett Packard Enterprise y recibirá ayuda telefónica por parte de un técnico. Con el envío de materiales para la sustitución de componentes CSR, Hewlett Packard Enterprise especificará si los componentes defectuosos deberán devolverse a Hewlett Packard Enterprise. En aquellos casos en los que sea necesario devolver algún componente a Hewlett Packard Enterprise,



deberá hacerlo en el periodo de tiempo especificado, normalmente cinco días laborables. Los componentes defectuosos deberán devolverse con toda la documentación relacionada y con el embalaje de envío. Si no enviara el componente defectuoso requerido, Hewlett Packard Enterprise podrá cobrarle por el de sustitución. En el caso de todas sustituciones que lleve a cabo el cliente, Hewlett Packard Enterprise se hará cargo de todos los gastos de envío y devolución de componentes y escogerá la empresa de transporte que se utilice para dicho servicio.

Para obtener más información acerca del programa de Reparaciones del propio cliente de Hewlett Packard Enterprise, póngase en contacto con su proveedor de servicios local. Si está interesado en el programa para Norteamérica, visite la página web de Hewlett Packard Enterprise CSR (<http://www.hpe.com/support/selfrepair>).

## Servicio de garantía exclusivo de componentes

La garantía limitada de Hewlett Packard Enterprise puede que incluya un servicio de garantía exclusivo de componentes. Según las condiciones de este servicio exclusivo de componentes, Hewlett Packard Enterprise le facilitará los componentes de repuesto sin cargo adicional alguno.

Para este servicio de garantía exclusivo de componentes, es obligatoria la sustitución de componentes por parte del usuario (CSR). Si solicita a Hewlett Packard Enterprise que realice la sustitución de estos componentes, tendrá que hacerse cargo de los gastos de desplazamiento y de mano de obra de dicho servicio.

## Customer Self Repair

Veel onderdelen in Hewlett Packard Enterprise producten zijn door de klant zelf te repareren, waardoor de reparatieduur tot een minimum beperkt kan blijven en de flexibiliteit in het vervangen van defecte onderdelen groter is. Deze onderdelen worden CSR-onderdelen (Customer Self Repair) genoemd. Als Hewlett Packard Enterprise (of een Hewlett Packard Enterprise Service Partner) bij de diagnose vaststelt dat de reparatie kan worden uitgevoerd met een CSR-onderdeel, verzendt Hewlett Packard Enterprise dat onderdeel rechtstreeks naar u, zodat u het defecte onderdeel daarmee kunt vervangen. Er zijn twee categorieën CSR-onderdelen:

- **Verplicht**—Onderdelen waarvoor reparatie door de klant verplicht is. Als u Hewlett Packard Enterprise verzoekt deze onderdelen voor u te vervangen, worden u voor deze service reiskosten en arbeidsloon in rekening gebracht.
- **Optioneel**—Onderdelen waarvoor reparatie door de klant optioneel is. Ook deze onderdelen zijn ontworpen voor reparatie door de klant. Als u echter Hewlett Packard Enterprise verzoekt deze onderdelen voor u te vervangen, kunnen daarvoor extra kosten in rekening worden gebracht, afhankelijk van het type garantieservice voor het product.

**OPMERKING:** Sommige Hewlett Packard Enterprise onderdelen zijn niet ontwikkeld voor reparatie door de klant. In verband met de garantievoorwaarden moet het onderdeel door een geautoriseerde Service Partner worden vervangen. Deze onderdelen worden in de geïllustreerde onderdelencatalogus aangemerkt met "Nee".

Afhankelijk van de leverbaarheid en de locatie worden CSR-onderdelen verzonden voor levering op de eerstvolgende werkdag. Levering op dezelfde dag of binnen vier uur kan tegen meerkosten worden aangeboden, indien dit mogelijk is gezien de locatie. Indien assistentie is gewenst, belt u het Hewlett Packard Enterprise Support Center om via de telefoon ondersteuning van een technicus te ontvangen. Hewlett Packard Enterprise vermeldt in de documentatie bij het vervangende CSR-onderdeel of het defecte onderdeel aan Hewlett Packard Enterprise moet worden geretourneerd. Als het defecte onderdeel aan Hewlett Packard Enterprise moet worden teruggezonden, moet u het defecte onderdeel binnen een bepaalde periode, gewoonlijk vijf (5) werkdagen, retourneren aan Hewlett Packard Enterprise. Het defecte onderdeel moet met de bijbehorende documentatie worden geretourneerd in het meegeleverde verpakkingsmateriaal. Als u het defecte onderdeel niet terugzendt, kan Hewlett Packard

Enterprise u voor het vervangende onderdeel kosten in rekening brengen. Bij reparatie door de klant betaalt Hewlett Packard Enterprise alle verzendkosten voor het vervangende en geretourneerde onderdeel en kiest Hewlett Packard Enterprise zelf welke koerier/transportonderneming hiervoor wordt gebruikt.

Neem contact op met een Service Partner voor meer informatie over het Customer Self Repair programma van Hewlett Packard Enterprise. Informatie over Service Partners vindt u op de Hewlett Packard Enterprise website (<http://www.hpe.com/support/selfrepair>).

## Garantieservice "Parts Only"

Het is mogelijk dat de Hewlett Packard Enterprise garantie alleen de garantieservice "Parts Only" omvat. Volgens de bepalingen van de Parts Only garantieservice zal Hewlett Packard Enterprise kosteloos vervangende onderdelen ter beschikking stellen.

Voor de Parts Only garantieservice is vervanging door CSR-onderdelen verplicht. Als u Hewlett Packard Enterprise verzoekt deze onderdelen voor u te vervangen, worden u voor deze service reiskosten en arbeidsloon in rekening gebracht

## Reparo feito pelo cliente

Os produtos da Hewlett Packard Enterprise são projetados com muitas peças para reparo feito pelo cliente (CSR) de modo a minimizar o tempo de reparo e permitir maior flexibilidade na substituição de peças com defeito. Se, durante o período de diagnóstico, a Hewlett Packard Enterprise (ou fornecedores/parceiros da Hewlett Packard Enterprise) concluir que o reparo pode ser efetuado pelo uso de uma peça CSR, a Hewlett Packard Enterprise enviará a peça diretamente ao cliente. Há duas categorias de peças CSR:

- **Obrigatória**—Peças cujo reparo feito pelo cliente é obrigatório. Se desejar que a Hewlett Packard Enterprise substitua essas peças, serão cobradas as despesas de transporte e mão-de-obra do serviço.
- **Opcional**—Peças cujo reparo feito pelo cliente é opcional. Essas peças também são projetadas para o reparo feito pelo cliente. No entanto, se desejar que a Hewlett Packard Enterprise as substitua, pode haver ou não a cobrança de taxa adicional, dependendo do tipo de serviço de garantia destinado ao produto.

**OBSERVAÇÃO:** Algumas peças da Hewlett Packard Enterprise não são projetadas para o reparo feito pelo cliente. A fim de cumprir a garantia do cliente, a Hewlett Packard Enterprise exige que um técnico autorizado substitua a peça. Essas peças estão identificadas com a marca "No" (Não), no catálogo de peças ilustrado.

Conforme a disponibilidade e o local geográfico, as peças CSR serão enviadas no primeiro dia útil após o pedido. Onde as condições geográficas permitirem, a entrega no mesmo dia ou em quatro horas pode ser feita mediante uma taxa adicional. Se precisar de auxílio, entre em contato com o Centro de suporte técnico da Hewlett Packard Enterprise para que um técnico o ajude por telefone. A Hewlett Packard Enterprise especifica nos materiais fornecidos com a peça CSR de reposição se a peça com defeito deve ser devolvida à Hewlett Packard Enterprise. Nos casos em que isso for necessário, é preciso enviar a peça com defeito à Hewlett Packard Enterprise, você deverá enviar a peça com defeito de volta para a Hewlett Packard Enterprise dentro do período de tempo definido, normalmente em 5 (cinco) dias úteis. A peça com defeito deve ser enviada com a documentação correspondente no material de transporte fornecido. Caso não o faça, a Hewlett Packard Enterprise poderá cobrar a reposição. Para as peças de reparo feito pelo cliente, a Hewlett Packard Enterprise paga todas as despesas de transporte e de devolução da peça e determina a transportadora/serviço postal a ser utilizado.

Para obter mais informações sobre o programa de reparo feito pelo cliente da Hewlett Packard Enterprise, entre em contato com o fornecedor de serviços local. Para o programa norte-americano, visite o site da Hewlett Packard Enterprise (<http://www.hpe.com/support/selfrepair>).

## Serviço de garantia apenas para peças

A garantia limitada da Hewlett Packard Enterprise pode incluir um serviço de garantia apenas para peças. Segundo os termos do serviço de garantia apenas para peças, a Hewlett Packard Enterprise fornece as peças de reposição sem cobrar nenhuma taxa.

No caso desse serviço, a substituição de peças CSR é obrigatória. Se desejar que a Hewlett Packard Enterprise substitua essas peças, serão cobradas as despesas de transporte e mão-de-obra do serviço.

## カスタマーセルフリペア

修理時間を短縮し、故障部品の交換における高い柔軟性を確保するために、Hewlett Packard Enterprise製品には多数のカスタマーセルフリペア（CSR）部品があります。診断の際に、CSR部品を使用すれば修理ができるかとHewlett Packard Enterprise（Hewlett Packard EnterpriseまたはHewlett Packard Enterprise正規保守代理店）が判断した場合、Hewlett Packard Enterpriseはその部品を直接、お客様に発送し、お客様に交換していただきます。CSR部品には以下の2種類があります。

- **必須** - カスタマーセルフリペアが必須の部品。当該部品について、もしもお客様がHewlett Packard Enterpriseに交換作業を依頼される場合には、その修理サービスに関する交通費および人件費がお客様に請求されます。
- **任意** - カスタマーセルフリペアが任意である部品。この部品もカスタマーセルフリペア用です。当該部品について、もしもお客様がHewlett Packard Enterpriseに交換作業を依頼される場合には、お買い上げの製品に適用される保証サービス内容の範囲内においては、別途費用を負担していただくことなく保証サービスを受けることができます。

注：Hewlett Packard Enterprise製品の一部の部品は、カスタマーセルフリペアの対象外です。製品の保証を継続するためには、Hewlett Packard EnterpriseまたはHewlett Packard Enterprise正規保守代理店による交換作業が必須となります。部品カタログには、当該部品がカスタマーセルフリペア除外品である旨が記載されています。

部品供給が可能な場合、地域によっては、CSR部品を翌営業日に届くように発送します。また、地域によっては、追加費用を負担いただくことにより同日または4時間以内に届くように発送することも可能な場合があります。サポートが必要なときは、Hewlett Packard Enterpriseサポートセンターに電話していただければ、技術者が電話でアドバイスします。交換用のCSR部品または同梱物には、故障部品をHewlett Packard Enterpriseに返送する必要があるかどうかが表示されています。故障部品をHewlett Packard Enterpriseに返送する必要がある場合は、指定期限内（通常は5営業日以内）に故障部品をHewlett Packard Enterpriseに返送してください。故障部品を返送する場合は、届いた時の梱包箱に関連書類とともにに入れてください。故障部品を返送しない場合、Hewlett Packard Enterpriseから部品費用が請求されます。カスタマーセルフリペアの際には、Hewlett Packard Enterpriseは送料および部品返送費を全額負担し、使用する宅配便会社や運送会社を指定します。

## 部品のみ保証サービス

Hewlett Packard Enterprise保証サービスには、部品のみ保証サービスが適用される場合があります。このサービスでは、交換部品は無償で提供されます。

部品のみ保証サービスにおいては、CSR部品をお客様により交換作業していただくことが必須となります。当該部品について、もしもお客様がHewlett Packard Enterpriseに交換作業を依頼される場合には、その修理サービスに関する交通費および人件費がお客様のご負担となります。

# 客户自行维修

Hewlett Packard Enterprise 产品提供许多客户自行维修 (CSR) 部件，以尽可能缩短维修时间和在更换缺陷部件方面提供更大的灵活性。如果在诊断期间 Hewlett Packard Enterprise (或 Hewlett Packard Enterprise 服务提供商或服务合作伙伴) 确定可以通过使用 CSR 部件完成维修，Hewlett Packard Enterprise 将直接把该部件发送给您进行更换。有两类 CSR 部件：

- **强制性的** — 要求客户必须自行维修的部件。如果您请求 Hewlett Packard Enterprise 更换这些部件，则必须为该服务支付差旅费和人工费用。
- **可选的** — 客户可以选择是否自行维修的部件。这些部件也是为客户自行维修设计的。不过，如果您要求 Hewlett Packard Enterprise 为您更换这些部件，则根据为您的产品指定的保修服务类型，Hewlett Packard Enterprise 可能收取或不再收取任何附加费用。

**注：**某些 Hewlett Packard Enterprise 部件的设计并未考虑客户自行维修。为了满足客户保修的需要，Hewlett Packard Enterprise 要求授权服务提供商更换相关部件。这些部件在部件图解目录中标记为“否”。

CSR 部件将在下一个工作日发运 (取决于备货情况和允许的地理范围)。在允许的地理范围内，可在当天或四小时内发运，但要收取额外费用。如果需要帮助，您可以致电 Hewlett Packard Enterprise 技术支持中心，将会有技术人员通过电话为您提供帮助。Hewlett Packard Enterprise 会在随更换的 CSR 部件发运的材料中指明是否必须将有缺陷的部件返还给 Hewlett Packard Enterprise。如果要求您将有缺陷的部件返还给 Hewlett Packard Enterprise，那么您必须在规定的期限内 (通常是五 (5) 个工作日) 将缺陷部件发给 Hewlett Packard Enterprise。有缺陷的部件必须随所提供的发运材料中的相关文件一起返还。如果未能送还有缺陷的部件，Hewlett Packard Enterprise 可能会要求您支付更换费用。客户自行维修时，Hewlett Packard Enterprise 将承担所有相关运输和部件返回费用，并指定快递商/承运商。

有关 Hewlett Packard Enterprise 客户自行维修计划的详细信息，请与您当地的服务提供商联系。有关北美地区的计划，请访问 Hewlett Packard Enterprise 网站 (<http://www.hpe.com/support/selfrepair>)。

## 仅部件保修服务

您的 Hewlett Packard Enterprise 有限保修服务可能涉及仅部件保修服务。根据仅部件保修服务条款的规定，Hewlett Packard Enterprise 将免费提供更换的部件。

仅部件保修服务要求进行 CSR 部件更换。如果您请求 Hewlett Packard Enterprise 更换这些部件，则必须为该服务支付差旅费和人工费用。

# 客戶自行維修

Hewlett Packard Enterprise 產品設計了許多「客戶自行維修」(CSR) 的零件以減少維修時間，並且使得更換瑕疵零件時能有更大的彈性。如果在診斷期間，Hewlett Packard Enterprise (或 Hewlett Packard Enterprise 服務供應商或維修夥伴) 辨認出此項維修工作可以藉由使用 CSR 零件來完成，則 Hewlett Packard Enterprise 將直接寄送該零件給您作更換。CSR 零件分為兩種類別：

- **強制的** — 客戶自行維修所使用的零件是強制性的。如果您要求 Hewlett Packard Enterprise 更換這些零件，Hewlett Packard Enterprise 將會向您收取此服務所需的外出費用與勞動成本。
- **選購的** — 客戶自行維修所使用的零件是選購的。這些零件也設計用於客戶自行維修之用。不過，如果您要求 Hewlett Packard Enterprise 為您更換，則可能需要也可能不需要負擔額外的費用，端視針對此產品指定的保固服務類型而定。

**備註：**某些 Hewlett Packard Enterprise 零件沒有消費者可自行維修的設計。為符合客戶保固，Hewlett Packard Enterprise 需要授權的服務供應商更換零件。這些零件在圖示的零件目錄中，被標示為「否」。

基於材料取得及環境允許的情況下，CSR 零件將於下一個工作日以快遞寄送。在環境的允許下當天或四小時內送達，則可能需要額外的費用。若您需要協助，可致電 Hewlett Packard Enterprise 支援中心，會有一位技術人員透過電話來協助您。不論損壞的零件是否必須退回，Hewlett Packard Enterprise 皆會在與 CSR 替換零件一起運送的材料中註明。若要將損壞的零件退回 Hewlett Packard Enterprise，您必須在指定的一段時間內 (通常為五 (5) 個工作天)，將損壞的零件寄回 Hewlett Packard Enterprise。損壞的零件必須與寄送資料中隨附的相關技術文件一併退還。如果無法退還損壞的零件，Hewlett Packard Enterprise 可能要向您收取替換費用。針對客戶自行維修情形，Hewlett Packard Enterprise 將負責所有運費及零件退還費用，並指定使用何家快遞/貨運公司。

如需 Hewlett Packard Enterprise 的 CSR 方案詳細資訊，請連絡您當地的服務供應商。至於北美方案，請參閱 Hewlett Packard Enterprise 的 CSR 網站 [selfrepair \(http://www.hpe.com/support/selfrepair\)](http://www.hpe.com/support/selfrepair)。

## 僅限零件的保固服務

您的「Hewlett Packard Enterprise 有限保固」可能包含僅限零件的保固服務。在僅限零件的保固服務情況下，Hewlett Packard Enterprise 將免費提供替換零件。

針對僅限零件的保固服務，CSR 零件替換是強制性的。如果您要求 Hewlett Packard Enterprise 更換這些零件，Hewlett Packard Enterprise 將會向您收取此服務所需的外出費用與勞動成本。

## 고객 셀프 수리

Hewlett Packard Enterprise 제품은 수리 시간을 최소화하고 결함이 있는 부품 교체 시 더욱 용동성을 발휘할 수 있도록 하기 위해 고객 셀프 수리(CSR) 부품을 다량 사용하여 설계되었습니다. 진단 기간 동안 Hewlett Packard Enterprise(또는 Hewlett Packard Enterprise 서비스 공급업체 또는 서비스 협력업체)에서 CSR 부품을 사용하여 수리가 가능하다고 판단되면 Hewlett Packard Enterprise는 해당 부품을 바로 사용자에게 보내어 사용자가 교체할 수 있도록 합니다. CSR 부품에는 두 가지 종류가 있습니다.

- 필수 - 고객 셀프 수리가 의무 사항인 필수 부품. 사용자가 Hewlett Packard Enterprise에 이 부품의 교체를 요청할 경우 이 서비스에 대한 출장비 및 작업비가 청구됩니다.
- 선택 사항 - 고객 셀프 수리가 선택 사항인 부품. 이 부품들도 고객 셀프 수리가 가능하도록 설계되었습니다. 하지만 사용자가 Hewlett Packard Enterprise에 이 부품의 교체를 요청할 경우 사용자가 구입한 제품에 해당하는 보증 서비스 유형에 따라 추가 비용 없이 교체가 가능할 수 있습니다.

참고: 일부 Hewlett Packard Enterprise 부품은 고객 셀프 수리가 불가능하도록 설계되었습니다. Hewlett Packard Enterprise는 만족스러운 고객 보증을 위해 공인 서비스 제공업체를 통해 부품을 교체하도록 하고 있습니다. 이러한 부품들은 Illustrated Parts Catalog에 “No”라고 표시되어 있습니다.

CSR 부품은 재고 상태와 지리적 조건이 허용하는 경우 다음 영업일 납품이 가능하도록 배송이 이루어집니다. 지리적 조건이 허용하는 경우 추가 비용이 청구되는 조건으로 당일 또는 4시간 배송이 가능할 수도 있습니다. 도움이 필요하시면 Hewlett Packard Enterprise Support Center로 전화하십시오. 전문 기술자가 전화로 도움을 줄 것입니다. Hewlett Packard Enterprise는 결함이 발생한 부품을 Hewlett Packard Enterprise로 반환해야 하는지 여부를 CSR 교체 부품과 함께 배송된 자료에 지정합니다. 결함이 발생한 부품을 Hewlett Packard Enterprise로 반환해야 하는 경우에는 지정된 기간 내(통상 영업일 기준 5일)에 Hewlett Packard Enterprise로 반환해야 합니다. 이때 결함이 발생한 부품은 제공된 포장 재료에 넣어 관련 설명서와 함께 반환해야 합니다. 결함이 발생한 부품을 반환하지 않는 경우 Hewlett Packard Enterprise가 교체 부품에 대해 비용을 청구할 수 있습니다. 고객 셀프 수리의 경우, Hewlett Packard Enterprise는 모든 운송 및 부품 반환 비용을 부담하며 이용할 운송업체 및 택배 서비스를 결정합니다.

Hewlett Packard Enterprise CSR 프로그램에 대한 자세한 내용은 가까운 서비스 제공업체에 문의하십시오. 북미 지역의 프로그램에 대해서는 Hewlett Packard Enterprise CSR 웹 사이트(<http://www.hpe.com/support/selfrepair>)를 참조하십시오.

## 부품 제공 보증 서비스

Hewlett Packard Enterprise 제한 보증에는 부품 제공 보증 서비스가 포함될 수 있습니다. 이러한 경우 Hewlett Packard Enterprise는 부품 제공 보증 서비스의 조건에 따라 교체 부품만을 무료로 제공합니다.

부품 제공 보증 서비스 제공 시 CSR 부품 교체는 의무 사항입니다. 사용자가 Hewlett Packard Enterprise에 이 부품의 교체를 요청할 경우 이 서비스에 대한 출장비 및 작업비가 청구됩니다.

# Illustrated parts catalog

## Mechanical components

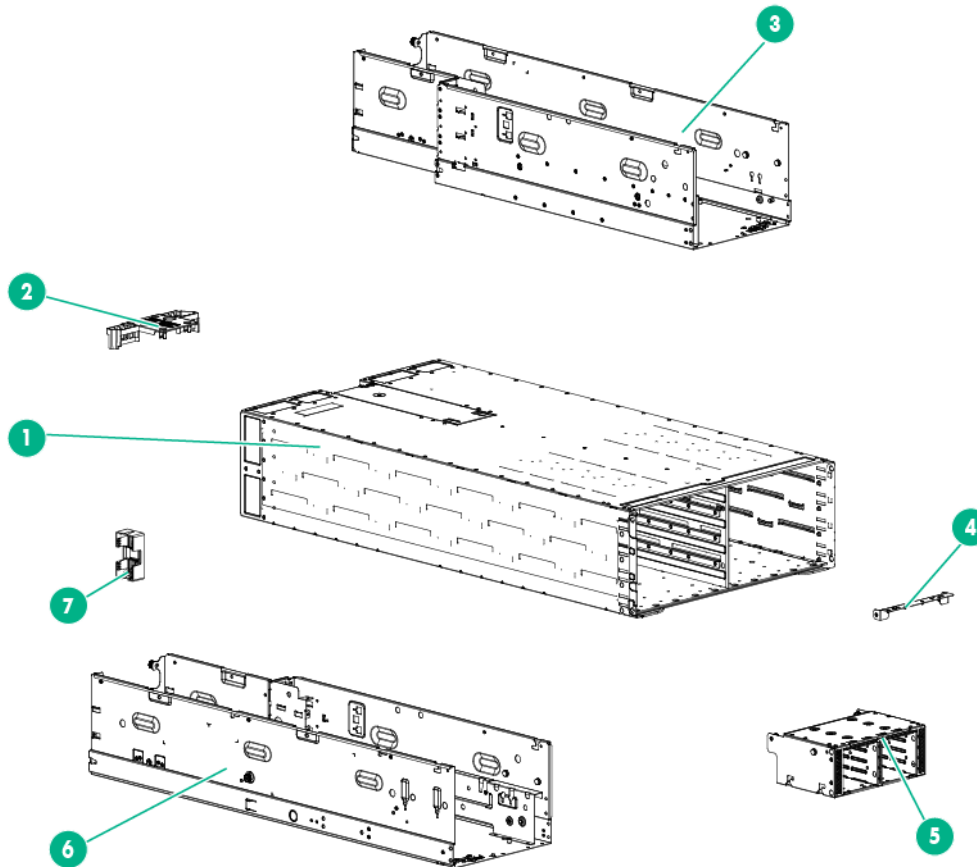

Item	Description	Spare part number	Customer self-repair ("Customer self repair" on page 5)
1	HPE ProLiant s6500 Chassis	—	—
2	Processor air baffle	669271-001	Mandatory <sup>1</sup>
3	HPE ProLiant SL270s Gen8 right tray	—	—
4	Shipping bracket	671782-001	Mandatory <sup>1</sup>
5	Hot-plug drive cage	671768-001	Mandatory <sup>1</sup>
6	HPE ProLiant SL270s Gen8 left tray	—	—
7	FBWC capacitor pack holder	669291-001	Optional <sup>2</sup>

<sup>1</sup>Mandatory—Parts for which customer self repair is mandatory. If you request Hewlett Packard Enterprise to replace these parts, you will be charged for the travel and labor costs of this service.

<sup>2</sup>Optional—Parts for which customer self repair is optional. These parts are also designed for customer self repair. If, however, you require that Hewlett Packard Enterprise replace them for you, there may or may not be additional charges, depending on the type of warranty service designated for your product.

<sup>3</sup>No—Some Hewlett Packard Enterprise parts are not designed for customer self repair. In order to satisfy the customer warranty, Hewlett Packard Enterprise requires that an authorized service provider replace the part. These parts are identified as "No" in the Illustrated Parts Catalog.

<sup>1</sup>Obligatoire—Pièces pour lesquelles le client doit procéder lui-même aux réparations. Si vous demandez à Hewlett Packard Enterprise de procéder au remplacement de ces pièces, les frais de transport et de main d'œuvre pour ce service vous seront facturés.

<sup>2</sup>Facultatif—Pièces pour lesquelles une réparation par le client est facultative. Ces pièces sont également conçues pour que le client puisse procéder lui-même aux réparations. Cependant, les frais supplémentaires engendrés par le remplacement de ces pièces par Hewlett Packard Enterprise dépendent du type de service de garantie désigné pour votre produit.

<sup>3</sup>Non—Certaines pièces Hewlett Packard Enterprise ne sont pas conçues pour être remplacées par le client. Afin de se conformer aux exigences de la garantie la garantie du client, Hewlett Packard Enterprise demande à un fournisseur de services agréé de procéder au remplacement de la pièce. Ces pièces sont signalées par le mot « Non » dans le Catalogue de pièces illustré.

<sup>1</sup>Obbligatorio—Parti per le quali il cliente è tenuto a effettuare autonomamente la riparazione. Se si richiede l'intervento di Hewlett Packard Enterprise per la sostituzione di queste parti, al cliente verranno addebitate le spese di viaggio e manodopera dell'operazione.

<sup>2</sup>Facoltativo—Parti per le quali la riparazione in autonomia da parte del cliente è facoltativa. Queste parti sono progettate per consentire anche la riparazione da parte del cliente. Tuttavia, se il cliente richiede l'intervento di Hewlett Packard Enterprise per la sostituzione, potrebbero essere addebitate spese aggiuntive a seconda del tipo di garanzia in assistenza previsto per il prodotto.

<sup>3</sup>No—Alcune parti Hewlett Packard Enterprise non sono progettate la riparazione in autonomia da parte del cliente. In base a quanto previsto dalla garanzia per il cliente, Hewlett Packard Enterprise richiede l'intervento di un tecnico autorizzato per la sostituzione della parte. Queste parti sono contrassegnate con "No" nel catalogo parti illustrato.

<sup>1</sup>Zwingend—Teile, für die das Customer Self Repair-Verfahren zwingend vorgegeben ist. Wenn Sie den Austausch dieser Teile von Hewlett Packard Enterprise vornehmen lassen, werden Ihnen die Anfahrt- und Arbeitskosten für diesen Service berechnet.

<sup>2</sup>Optional—Teile, für die das Customer Self Repair-Verfahren optional ist. Diese Teile sind auch für Customer Self Repair ausgelegt. Wenn Sie jedoch den Austausch dieser Teile von Hewlett Packard Enterprise vornehmen lassen möchten, können bei diesem Service je nach den für Ihr Produkt vorgesehenen Garantiebedingungen zusätzliche Kosten anfallen.

<sup>3</sup>Nein—Einige Hewlett Packard Enterprise Teile sind nicht für Customer Self Repair ausgelegt. Um den Garantieanspruch des Kunden zu erfüllen, muss das Teil von einem Hewlett Packard Enterprise Servicepartner ersetzt werden. Im illustrierten Teilekatalog sind diese Teile mit „No“ bzw. „Nein“ gekennzeichnet.

<sup>1</sup>Obligatorio—Componentes cuya reparación por parte del usuario es obligatoria. Si solicita a Hewlett Packard Enterprise que realice la sustitución de estos componentes, tendrá que hacerse cargo de los gastos de desplazamiento y de mano de obra de dicho servicio.

<sup>2</sup>Opcional—Componentes cuya reparación por parte del usuario es opcional. Estos componentes también están diseñados para que puedan ser reparados por el usuario. Sin embargo, si precisa que Hewlett Packard Enterprise realice su sustitución, puede o no conllevar costes adicionales, dependiendo del tipo de servicio de garantía correspondiente al producto.

<sup>3</sup>No—Algunos componentes de Hewlett Packard Enterprise no están diseñados para que puedan ser reparados por el usuario. Para que el usuario haga valer su garantía, Hewlett Packard Enterprise pone como condición que un proveedor de servicios autorizado realice la sustitución de estos componentes. Dichos componentes se identifican con la palabra "No" en el catálogo ilustrado de componentes.

<sup>1</sup>Verplicht—Onderdelen die de klant zelf moet vervangen. Als u Hewlett Packard Enterprise vraagt deze onderdelen te vervangen, worden er reis- en arbeidskosten voor deze service in rekening gebracht.

<sup>2</sup>Optioneel—Onderdelen die de klant zelf kan vervangen. Deze onderdelen zijn ook ontworpen om door de klant zelf te worden vervangen. Als u Hewlett Packard Enterprise verzoekt om deze te vervangen, kan het zijn dat hiervoor extra kosten in rekening worden gebracht, afhankelijk van het soort garantie dat op uw product van toepassing is.

<sup>3</sup>Geen—Sommige onderdelen van Hewlett Packard Enterprise zijn niet ontworpen om door de klant zelf te worden vervangen. Om te voldoen aan de garantievoorwaarden eist Hewlett Packard Enterprise dat een geautoriseerde serviceverlener het onderdeel vervangt. Deze onderdelen worden aangeduid met 'Geen' in de geïllustreerde onderdelencatalogus.



<sup>1</sup>Obrigatório—Peças cujo reparo feito pelo cliente é obrigatório. Se desejar que a Hewlett Packard Enterprise substitua essas peças, serão cobradas as despesas de transporte e mão-de-obra do serviço.

<sup>2</sup>Opcional—Peças cujo reparo feito pelo cliente é opcional. Essas peças também são projetadas para o reparo feito pelo cliente. No entanto, se desejar que a Hewlett Packard Enterprise as substitua, pode haver ou não a cobrança de taxa adicional, dependendo do tipo de serviço de garantia destinado ao produto.

<sup>3</sup>Não—Algumas peças da Hewlett Packard Enterprise não são projetadas para o reparo feito pelo cliente. A fim de cumprir a garantia do cliente, a Hewlett Packard Enterprise exige que um técnico autorizado substitua a peça. Essas peças estão identificadas com a marca "No" (Não), no catálogo de peças ilustrado.

<sup>1</sup>Mandatory : 必須 — カスタマーセルフリペアが必須の部品。当該部品について、もしもお客様がHewlett Packard Enterpriseに交換作業を依頼される場合には、その修理サービスに関する交通費および人件費がお客様に請求されます。

<sup>2</sup>Optional : 任意 — カスタマーセルフリペアが任意である部品。この部品もカスタマーセルフリペア用です。当該部品について、もしもお客様がHewlett Packard Enterpriseに交換作業を依頼される場合には、お買い上げの製品に適用される保証サービス内容の範囲内においては、別途費用を負担していただくことなく保証サービスを受けることができます。

<sup>3</sup>No : 除外 — Hewlett Packard Enterprise製品の一部の部品は、カスタマーセルフリペアの対象外です。製品の保証を継続するためには、Hewlett Packard EnterpriseまたはHewlett Packard Enterprise正規保守代理店による交換作業が必須となります。部品カタログには、当該部品がカスタマーセルフリペア除外品である旨が記載されています。

<sup>1</sup>Mandatory — 客户必须自行维修的部件。如果您请求 Hewlett Packard Enterprise 更换这些部件，则必须为该服务支付差旅费和人工费用。

<sup>2</sup>Optional — 客户可以选择是否自行维修的部件。这些部件也是为客户自行维修设计的。不过，如果您要求 Hewlett Packard Enterprise 为您更换这些部件，则根据为您的产品指定的保修服务类型，Hewlett Packard Enterprise 可能收取或不再收取任何附加费用。

<sup>3</sup>No — 某些 Hewlett Packard Enterprise 部件的设计并未考虑客户自行维修。为了满足客户保修的需要，Hewlett Packard Enterprise 要求授权服务提供商更换相关部件。这些部件在部件图解目录中标记为“否”。

<sup>1</sup>Mandatory — 客戶自行維修所使用的零件是強制性的。如果您要求 Hewlett Packard Enterprise 更換這些零件，Hewlett Packard Enterprise 將會向您收取此服務所需的外出費用與勞動成本。

<sup>2</sup>Optional — 客戶自行維修所使用的零件是選購的。這些零件也設計用於客戶自行維修之用。不過，如果您要求 Hewlett Packard Enterprise 為您更換，則可能需要也可能不需要負擔額外的費用，端視針對此產品指定的保固服務類型而定。

<sup>3</sup>No — 某些 Hewlett Packard Enterprise 零件沒有消費者可自行維修的設計。為符合客戶保固，Hewlett Packard Enterprise 需要授權的服務供應商更換零件。這些零件在圖示的零件目錄中，被標示為「否」。

<sup>1</sup>Mandatory — 고객 셀프 수리가 의무 사항인 필수 부품. 사용자가 Hewlett Packard Enterprise에 이 부품의 교체를 요청할 경우 해당 서비스에 대한 출장비 및 작업비가 청구됩니다.

<sup>2</sup>Optional — 고객 셀프 수리가 선택 사항인 부품. 이러한 부품들도 고객 셀프 수리가 가능하도록 설계되었습니다. 하지만 사용자가 Hewlett Packard Enterprise에 이러한 부품의 교체를 요청할 경우 사용자가 구입한 제품에 해당하는 보증 서비스 유형에 따라 추가 비용 없이 교체가 가능할 수 있습니다.

<sup>3</sup>No — 일부 Hewlett Packard Enterprise 부품은 고객 셀프 수리가 불가능하도록 설계되었습니다. Hewlett Packard Enterprise는 만족스러운 고객 보증을 위해 공인 서비스 제공업체를 통해 부품을 교체하도록 요구하고 있습니다. 이러한 부품들은 Illustrated Parts Catalog에 "No"라고 표시되어 있습니다.

# System components

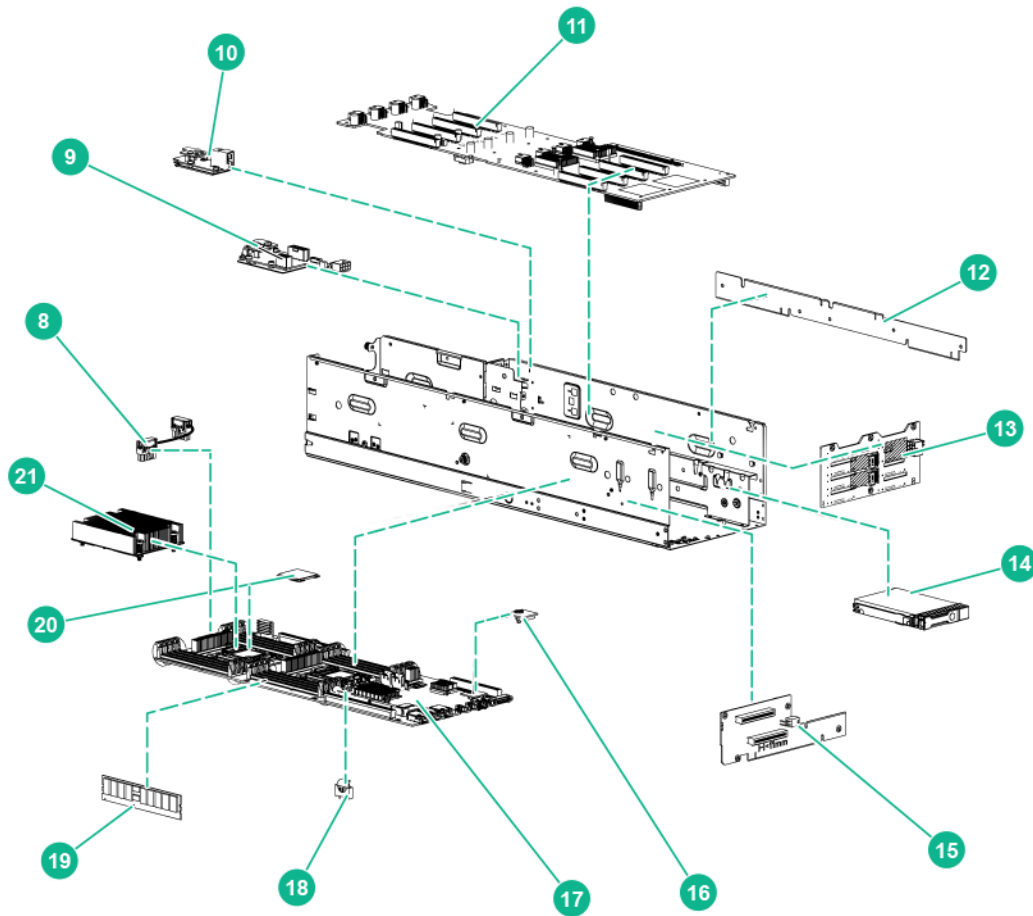

Item	Description	Spare part number	Customer self repair (on page 5)
8	Cables	—	—
	a) System board power cable, left	669284-001	Mandatory <sup>1</sup>
	b) Mini-SAS cable, SFF (labeled PORT1/PORT2)*	671786-001	Mandatory <sup>1</sup>
	c) GPU power capping cable*	708915-001	Mandatory <sup>1</sup>
	d) Riser cable*	671788-001	Mandatory <sup>1</sup>
	e) Power cable extender*	641852-001	Mandatory <sup>1</sup>
	f) Drive Mini-SAS cable*	680068-001	Mandatory <sup>1</sup>
	g) Controller cable, U-type*	680069-001	Mandatory <sup>1</sup>
	h) Controller cable, RA*	680070-001	Mandatory <sup>1</sup>
	i) Mezzanine board power cable*	742633-001	Mandatory <sup>1</sup>
	j) Rear GPU power cable*	742634-001	Mandatory <sup>1</sup>

Item	Description	Spare part number	Customer self repair (on page 5)
	k) Rear GPU power adapter cable*	742635-001	Mandatory <sup>1</sup>
	l) Front GPU power cable*	742636-001	Mandatory <sup>1</sup>
	m) Front GPU power adapter cable*	742637-001	Mandatory <sup>1</sup>
	n) Personality backplane power capping cable*	742638-001	Mandatory <sup>1</sup>
	o) GPU power capping cable*	742639-001	Mandatory <sup>1</sup>
	p) Drive power cable*	680067-001	Mandatory <sup>1</sup>
	q) Smart Array Mini-SAS Y-cable*	740833-001	Mandatory <sup>1</sup>
	r) RPS cable	—	—
	i) Left	733989-001	Mandatory <sup>1</sup>
	ii) Right	733176-001	Mandatory <sup>1</sup>
9	Personality board	—	—
	a) Left node	742628-001	Optional <sup>2</sup>
	b) Right node	742640-001	Optional <sup>2</sup>
10	L2 power board	—	—
	a) Left node	742629-001	Optional <sup>2</sup>
	b) Right node	742641-001	Optional <sup>2</sup>
11	Mezzanine board	—	—
	a) Left node	733991-001	Optional <sup>2</sup>
	b) Right node	733990-001	Optional <sup>2</sup>
12	X32 riser board	742923-001	Optional <sup>2</sup>
13	Drive backplane board	671768-001	Optional <sup>2</sup>
	<b>Drives</b>	—	—
14	SFF hot-plug drives in HPE SmartDrive carrier (6.35 cm, 2.5 in)	—	—
	SATA solid state drives	—	—
	a) 100 GB, 3G, MLC solid state drive	637070-001	Mandatory <sup>1</sup>
	b) 100 GB, 3G, MLC solid state drive*	653965-001	Mandatory <sup>1</sup>
	c) 200 GB, 3G, MLC solid state drive*	637071-001	Mandatory <sup>1</sup>
	d) 200 GB, 3G, MLC solid state drive*	653966-001	Mandatory <sup>1</sup>
	e) 400 GB, 3G, MLC solid state drive*	637072-001	Mandatory <sup>1</sup>
	f) 400 GB, 3G, MLC solid state drive*	653967-001	Mandatory <sup>1</sup>
	SATA hard drives	—	—
	a) 500 GB, 6G, 7,200-rpm MDL hard drive*	626164-001	Mandatory <sup>1</sup>
	b) 500 GB, 3G, 7,200-rpm, MDL hard drive*	656104-001	Mandatory <sup>1</sup>
	c) 500 GB, 6G, 7,200-rpm, MDL hard drive*	656107-001	Mandatory <sup>1</sup>

<b>Item</b>	<b>Description</b>	<b>Spare part number</b>	<b>Customer self repair (on page 5)</b>
	d) 1 TB, 3G, 7,200-rpm, MDL hard drive*	656105-001	Mandatory <sup>1</sup>
	e) 1 TB, 6G, 7,200-rpm, MDL hard drive*	626165-001	Mandatory <sup>1</sup>
	f) 1 TB, 6G, 7,200-rpm, MDL hard drive*	656108-001	Mandatory <sup>1</sup>
	SAS solid state drives	—	—
	a) 100 GB, MLC solid state drive*	657280-001	Mandatory <sup>1</sup>
	b) 100 GB, SLC solid state drive*	657277-001	Mandatory <sup>1</sup>
	c) 200 GB, MLC solid state drive*	657281-001	Mandatory <sup>1</sup>
	d) 200 GB, SLC solid state drive*	632627-001	Mandatory <sup>1</sup>
	e) 200 GB, MLC solid state drive*	632633-001	Mandatory <sup>1</sup>
	f) 200 GB, SLC solid state drive*	653961-001	Mandatory <sup>1</sup>
	g) 200 GB, SLC solid state drive*	657278-001	Mandatory <sup>1</sup>
	h) 200 GB, MLC solid state drive*	658580-001	Mandatory <sup>1</sup>
	i) 400 GB, SLC solid state drive*	632630-001	Mandatory <sup>1</sup>
	j) 400 GB, MLC solid state drive*	632636-001	Mandatory <sup>1</sup>
	k) 400 GB, SLC solid state drive*	653962-001	Mandatory <sup>1</sup>
	l) 400 GB, MLC solid state drive*	653963-001	Mandatory <sup>1</sup>
	m) 400 GB, SLC solid state drive*	657279-001	Mandatory <sup>1</sup>
	n) 400 GB, MLC solid state drive*	657282-001	Mandatory <sup>1</sup>
	o) 800 GB, MLC solid state drive*	632639-001	Mandatory <sup>1</sup>
	p) 800 GB, MLC solid state drive*	653964-001	Mandatory <sup>1</sup>
	q) 800 GB, MLC solid state drive*	657283-001	Mandatory <sup>1</sup>
	SAS hard drives	—	—
	a) 72 GB, 6G, 15,000-rpm, DP ENT hard drive*	653949-001	Mandatory <sup>1</sup>
	b) 146 GB, 6G, 15,000-rpm, DP ENT hard drive*	653950-001	Mandatory <sup>1</sup>
	c) 300 GB, 6G, 10,000-rpm, DP ENT hard drive*	653955-001	Mandatory <sup>1</sup>
	d) 300 GB, 6G, 15,000-rpm, DP ENT hard drive*	627195-001	Mandatory <sup>1</sup>
	e) 300 GB, 6G, 15,000-rpm, DP ENT hard drive*	653960-001	Mandatory <sup>1</sup>
	f) 450 GB, 6G, 10,000-rpm, DP ENT hard drive*	653956-001	Mandatory <sup>1</sup>
	g) 500 GB, 6G, 7,200-rpm, DP MDL hard drive*	653953-001	Mandatory <sup>1</sup>
	h) 600 GB, 6G, 10,000-rpm, DP ENT hard drive*	653957-001	Mandatory <sup>1</sup>
	i) 900 GB, 10,000-rpm, DP ENT hard drive*	619463-001	Mandatory <sup>1</sup>
	j) 900 GB, 6G, 10,000-rpm, DP ENT hard drive*	653971-001	Mandatory <sup>1</sup>
	k) 1 TB, 6G, 7,200-rpm, DP MDL hard drive*	653954-001	Mandatory <sup>1</sup>

Item	Description	Spare part number	Customer self repair (on page 5)
15	PCIe/FlexibleLOM X24 riser board	742630-001	Optional <sup>2</sup>
16	HP Trusted Platform Module	450168-001	No <sup>3</sup>
17	System board	741758-001	Optional <sup>2</sup>
18	System battery, 3.3-V Lithium	153099-001	Mandatory <sup>1</sup>
19	Memory	—	—
	a) 2 GB DIMM, PC3-14900E, 256 M x8	715269-001	Mandatory <sup>1</sup>
	b) 2 GB DIMM, PC3L-12800E, 256 M x8	715279-001	Mandatory <sup>1</sup>
	b) 4 GB DIMM, PC3L-12800R, 512 M x4	715282-001	Mandatory <sup>1</sup>
	c) 4 GB DIMM, PC3L-12800R, 256 M x8	715280-001	Mandatory <sup>1</sup>
	e) 4 GB DIMM, PC3-14900E, 256 M x8	715270-001	Mandatory <sup>1</sup>
	f) 4 GB DIMM, PC3-14900R, 512 M x4	715272-001	Mandatory <sup>1</sup>
	g) 8 GB DIMM, PC3-14900E, 512 M x8	715271-001	Mandatory <sup>1</sup>
	h) 8 GB DIMM, PC3-14900R, 512 M x4	715273-001	Mandatory <sup>1</sup>
	i) 8 GB DIMM, PC3-14900R, 1 G x4	735303-001	Mandatory <sup>1</sup>
	j) 8 GB DIMM, PC3L-12800E, 512x8	715281-001	Mandatory <sup>1</sup>
	k) 8 GB DIMM, PC3L-12800R, 512x4	715283-001	Mandatory <sup>1</sup>
	l) 8 GB DIMM, PC3L-12800R, 1 Gx4	735302-001	Mandatory <sup>1</sup>
	m) 16 GB DIMM, PC3-14900R,1G x4	715274-001	Mandatory <sup>1</sup>
	n) 16 GB DIMM, PC3L-12800R, 1 Gx4	715284-001	Mandatory <sup>1</sup>
	o) 32 GB DIMM, PC3-14900L, 1 G x4	715275-001	Mandatory <sup>1</sup>
20	Processors	—	—
	a) 1.7 GHz., 25M, 70 W, Intel Xeon processor, E5-2650Lv2 10C**	730250-001	Mandatory <sup>1</sup>
	b) 2.2 GHz, 25M, 95 W, Intel Xeon processor, E5-2660v2 10C**	730237-001	Mandatory <sup>1</sup>
	c) 2.4 GHz, 30M, 115 W, Intel Xeon processor, E5-2695v2 12C**	730246-001	Mandatory <sup>1</sup>
	d) 2.5 GHz., 10M, 80W, Intel Xeon processor,E5-2609v2 4C**	730242-001	Mandatory <sup>1</sup>
	e) 2.5 GHz., 25M, 115W, Intel Xeon processor,E5-2670v2 10C**	730236-001	Mandatory <sup>1</sup>
	f) 2.6 GHz, 15M, 80 W, Intel Xeon processor, E5-2630v2 6C**	730240-001	Mandatory <sup>1</sup>
	g) 2.6 GHz, 20M, 95 W, Intel Xeon processor, E5-2650v2 8C**	730238-001	Mandatory <sup>1</sup>
	h) 2.7 GHz., 30M, 130 W, Intel Xeon processor, E5-2697v2 12C**	730245-001	Mandatory <sup>1</sup>
	i) 2.8 GHz, 25M, 115 W, Intel Xeon processor, E5-2680v2 10C**	730235-001	Mandatory <sup>1</sup>
	j) 3.0 GHz, 25M, 130 W, Intel Xeon processor, E5-2690v2 10C**	730234-001	Mandatory <sup>1</sup>
	k) 3.3 GHz, 25M, 130 W, Intel Xeon processor, E5-2643v2 6C**	730248-001	Mandatory <sup>1</sup>
	l) 3.5 GHz, 15M, 130 W, Intel Xeon processor, E5-2637v2 4C**	730249-001	Mandatory <sup>1</sup>

Item	Description	Spare part number	Customer self repair (on page 5)
21	Heatsinks	—	—
	a) Heatsink, processor 1	738023-001	Mandatory <sup>1</sup>
	b) Heatsink, processor 2*	738022-001	Mandatory <sup>1</sup>
22	x24 LPLOM*	733992-001	Mandatory <sup>1</sup>

\* Not shown

\*\*All processors in this HPE ProLiant server must have the same cache size, speed, number of cores, and rated maximum power consumption.

<sup>1</sup>Mandatory—Parts for which customer self repair is mandatory. If you request Hewlett Packard Enterprise to replace these parts, you will be charged for the travel and labor costs of this service.

<sup>2</sup>Optional—Parts for which customer self repair is optional. These parts are also designed for customer self repair. If, however, you require that Hewlett Packard Enterprise replace them for you, there may or may not be additional charges, depending on the type of warranty service designated for your product.

<sup>3</sup>No—Some Hewlett Packard Enterprise parts are not designed for customer self repair. In order to satisfy the customer warranty, Hewlett Packard Enterprise requires that an authorized service provider replace the part. These parts are identified as "No" in the Illustrated Parts Catalog.

<sup>1</sup>Obligatoire—Pièces pour lesquelles le client doit procéder lui-même aux réparations. Si vous demandez à Hewlett Packard Enterprise de procéder au remplacement de ces pièces, les frais de transport et de main d'œuvre pour ce service vous seront facturés.

<sup>2</sup>Facultatif—Pièces pour lesquelles une réparation par le client est facultative. Ces pièces sont également conçues pour que le client puisse procéder lui-même aux réparations. Cependant, les frais supplémentaires engendrés par le remplacement de ces pièces par Hewlett Packard Enterprise dépendent du type de service de garantie désigné pour votre produit.

<sup>3</sup>Non—Certaines pièces Hewlett Packard Enterprise ne sont pas conçues pour être remplacées par le client. Afin de se conformer aux exigences de la garantie la garantie du client, Hewlett Packard Enterprise demande à un fournisseur de services agréé de procéder au remplacement de la pièce. Ces pièces sont signalées par le mot « Non » dans le Catalogue de pièces illustré.

<sup>1</sup>Obbligatorio—Parti per le quali il cliente è tenuto a effettuare autonomamente la riparazione. Se si richiede l'intervento di Hewlett Packard Enterprise per la sostituzione di queste parti, al cliente verranno addebitate le spese di viaggio e manodopera dell'operazione.

<sup>2</sup>Facoltativo—Parti per le quali la riparazione in autonomia da parte del cliente è facoltativa. Queste parti sono progettate per consentire anche la riparazione da parte del cliente. Tuttavia, se il cliente richiede l'intervento di Hewlett Packard Enterprise per la sostituzione, potrebbero essere addebitate spese aggiuntive a seconda del tipo di garanzia in assistenza previsto per il prodotto.

<sup>3</sup>No—Alcune parti Hewlett Packard Enterprise non sono progettate la riparazione in autonomia da parte del cliente. In base a quanto previsto dalla garanzia per il cliente, Hewlett Packard Enterprise richiede l'intervento di un tecnico autorizzato per la sostituzione della parte. Queste parti sono contrassegnate con "No" nel catalogo parti illustrato.

<sup>1</sup>Zwingend—Teile, für die das Customer Self Repair-Verfahren zwingend vorgegeben ist. Wenn Sie den Austausch dieser Teile von Hewlett Packard Enterprise vornehmen lassen, werden Ihnen die Anfahrt- und Arbeitskosten für diesen Service berechnet.

<sup>2</sup>Optional—Teile, für die das Customer Self Repair-Verfahren optional ist. Diese Teile sind auch für Customer Self Repair ausgelegt. Wenn Sie jedoch den Austausch dieser Teile von Hewlett Packard Enterprise vornehmen lassen möchten, können bei diesem Service je nach den für Ihr Produkt vorgesehenen Garantiebedingungen zusätzliche Kosten anfallen.

<sup>3</sup>Nein—Einige Hewlett Packard Enterprise Teile sind nicht für Customer Self Repair ausgelegt. Um den Garantieanspruch des Kunden zu erfüllen, muss das Teil von einem Hewlett Packard Enterprise Servicepartner ersetzt werden. Im illustrierten Teilekatalog sind diese Teile mit „No“ bzw. „Nein“ gekennzeichnet.

<sup>1</sup>Obligatorio—Componentes cuya reparación por parte del usuario es obligatoria. Si solicita a Hewlett Packard Enterprise que realice la sustitución de estos componentes, tendrá que hacerse cargo de los gastos de desplazamiento y de mano de obra de dicho servicio.

<sup>2</sup>Opcional—Componentes cuya reparación por parte del usuario es opcional. Estos componentes también están diseñados para que puedan ser reparados por el usuario. Sin embargo, si precisa que Hewlett Packard Enterprise realice su sustitución, puede o no conllevar costes adicionales, dependiendo del tipo de servicio de garantía correspondiente al producto.

<sup>3</sup>No—Algunos componentes de Hewlett Packard Enterprise no están diseñados para que puedan ser reparados por el usuario. Para que el usuario haga valer su garantía, Hewlett Packard Enterprise pone como condición que un proveedor de servicios autorizado realice la sustitución de estos componentes. Dichos componentes se identifican con la palabra "No" en el catálogo ilustrado de componentes.

<sup>1</sup>Verplicht—Onderdelen die de klant zelf moet vervangen. Als u Hewlett Packard Enterprise vraagt deze onderdelen te vervangen, worden er reis- en arbeidskosten voor deze service in rekening gebracht.

<sup>2</sup>Optioneel—Onderdelen die de klant zelf kan vervangen. Deze onderdelen zijn ook ontworpen om door de klant zelf te worden vervangen. Als u Hewlett Packard Enterprise verzoekt om deze te vervangen, kan het zijn dat hiervoor extra kosten in rekening worden gebracht, afhankelijk van het soort garantie dat op uw product van toepassing is.

<sup>3</sup>Geen—Sommige onderdelen van Hewlett Packard Enterprise zijn niet ontworpen om door de klant zelf te worden vervangen. Om te voldoen aan de garantievoorwaarden eist Hewlett Packard Enterprise dat een geautoriseerde serviceverlener het onderdeel vervangt. Deze onderdelen worden aangeduid met 'Geen' in de geïllustreerde onderdelencatalogus.

<sup>1</sup>Obrigatório—Peças cujo reparo feito pelo cliente é obrigatório. Se desejar que a Hewlett Packard Enterprise substitua essas peças, serão cobradas as despesas de transporte e mão-de-obra do serviço.

<sup>2</sup>Opcional—Peças cujo reparo feito pelo cliente é opcional. Essas peças também são projetadas para o reparo feito pelo cliente. No entanto, se desejar que a Hewlett Packard Enterprise as substitua, pode haver ou não a cobrança de taxa adicional, dependendo do tipo de serviço de garantia destinado ao produto.

<sup>3</sup>Não—Algumas peças da Hewlett Packard Enterprise não são projetadas para o reparo feito pelo cliente. A fim de cumprir a garantia do cliente, a Hewlett Packard Enterprise exige que um técnico autorizado substitua a peça. Essas peças estão identificadas com a marca "No" (Não), no catálogo de peças ilustrado.

<sup>1</sup>Mandatory : 必須 — カスタマーセルフリペアが必須の部品。当該部品について、もしもお客様がHewlett Packard Enterpriseに交換作業を依頼される場合には、その修理サービスに関する交通費および人件費がお客様に請求されます。

<sup>2</sup>Optional : 任意 — カスタマーセルフリペアが任意である部品。この部品もカスタマーセルフリペア用です。当該部品について、もしもお客様がHewlett Packard Enterpriseに交換作業を依頼される場合には、お買い上げの製品に適用される保証サービス内容の範囲内においては、別途費用を負担していただくことなく保証サービスを受けることができます。

<sup>3</sup>No : 除外 — Hewlett Packard Enterprise製品の一部の部品は、カスタマーセルフリペアの対象外です。製品の保証を継続するためには、Hewlett Packard EnterpriseまたはHewlett Packard Enterprise正規保守代理店による交換作業が必須となります。部品カタログには、当該部品がカスタマーセルフリペア除外品である旨が記載されています。

<sup>1</sup>Mandatory — 客户必须自行维修的部件。如果您请求 Hewlett Packard Enterprise 更换这些部件，则必须为该服务支付差旅费和人工费用。

<sup>2</sup>Optional — 客户可以选择是否自行维修的部件。这些部件也是为客户自行维修设计的。不过，如果您要求 Hewlett Packard Enterprise 为您更换这些部件，则根据为您的产品指定的保修服务类型，Hewlett Packard Enterprise 可能收取或不再收取任何附加费用。

<sup>3</sup>No — 某些 Hewlett Packard Enterprise 部件的设计并未考虑客户自行维修。为了满足客户保修的需要，Hewlett Packard Enterprise 要求授权服务提供商更换相关部件。这些部件在部件图解目录中标记为“否”。

<sup>1</sup>Mandatory — 客户自行维修所使用的零件是强制性的。如果您要求 Hewlett Packard Enterprise 更换这些零件，Hewlett Packard Enterprise 将会向您收取此服务所需的外出费用与劳动成本。

<sup>2</sup>Optional — 客户自行维修所使用的零件是選購的。這些零件也設計用於客戶自行維修之用。不過，如果您要求 Hewlett Packard Enterprise 為您更換，則可能需要也可能不需要負擔額外的費用，端視針對此產品指定的保固服務類型而定。

<sup>3</sup>No — 某些 Hewlett Packard Enterprise 零件沒有消費者可自行維修的設計。為符合客戶保固，Hewlett Packard Enterprise 需要授權的服務供應商更換零件。這些零件在圖示的零件目錄中，被標示為「否」。

<sup>1</sup>Mandatory — 고객 셀프 수리가 의무 사항인 필수 부품. 사용자가 Hewlett Packard Enterprise에 이 부품의 교체를 요청할 경우 해당 서비스에 대한 출장비 및 작업비가 청구됩니다.

<sup>2</sup>Optional — 고객 셀프 수리가 선택 사항인 부품. 이러한 부품들도 고객 셀프 수리가 가능하도록 설계되었습니다. 하지만 사용자가 Hewlett Packard Enterprise에 이러한 부품의 교체를 요청할 경우 사용자가 구입한 제품에 해당하는 보증 서비스 유형에 따라 추가 비용 없이 교체가 가능할 수 있습니다.

<sup>3</sup>No — 일부 Hewlett Packard Enterprise 부품은 고객 셀프 수리가 불가능하도록 설계되었습니다. Hewlett Packard Enterprise는 만족스러운 고객 보증을 위해 공인 서비스 제공업체를 통해 부품을 교체하도록 요구하고 있습니다. 이러한 부품들은 Illustrated Parts Catalog에 "No"라고 표시되어 있습니다.

# Removal and replacement procedures

## Required tools

You need the following items for some procedures:

- T-10/T-15 Torx screwdriver
- HPE Insight Diagnostics software ("[HPE Insight Diagnostics](#)" on page 59)

## Safety considerations

Before performing service procedures, review all the safety information.

### Preventing electrostatic discharge

To prevent damaging the system, be aware of the precautions you need to follow when setting up the system or handling parts. A discharge of static electricity from a finger or other conductor may damage system boards or other static-sensitive devices. This type of damage may reduce the life expectancy of the device.

To prevent electrostatic damage:

- Avoid hand contact by transporting and storing products in static-safe containers.
- Keep electrostatic-sensitive parts in their containers until they arrive at static-free workstations.
- Place parts on a grounded surface before removing them from their containers.
- Avoid touching pins, leads, or circuitry.
- Always be properly grounded when touching a static-sensitive component or assembly.

## Symbols on equipment

The following symbols may be placed on equipment to indicate the presence of potentially hazardous conditions.



This symbol indicates the presence of hazardous energy circuits or electric shock hazards. Refer all servicing to qualified personnel.

**WARNING:** To reduce the risk of injury from electric shock hazards, do not open this enclosure. Refer all maintenance, upgrades, and servicing to qualified personnel.



This symbol indicates the presence of electric shock hazards. The area contains no user or field serviceable parts. Do not open for any reason.

**WARNING:** To reduce the risk of injury from electric shock hazards, do not open this enclosure.



This symbol on an RJ-45 receptacle indicates a network interface connection.

**WARNING:** To reduce the risk of electric shock, fire, or damage to the equipment, do not plug telephone or telecommunications connectors into this receptacle.



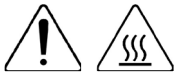

This symbol indicates the presence of a hot surface or hot component. If this surface is contacted, the potential for injury exists.

**WARNING:** To reduce the risk of injury from a hot component, allow the surface to cool before touching.

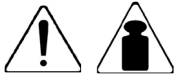

21.32 kg  
47 lb

This symbol indicates that the component exceeds the recommended weight for one individual to handle safely.

**WARNING:** To reduce the risk of personal injury or damage to the equipment, observe local occupational health and safety requirements and guidelines for manual material handling.



These symbols, on power supplies or systems, indicate that the equipment is supplied by multiple sources of power.

**WARNING:** To reduce the risk of injury from electric shock, remove all power cords to completely disconnect power from the system.

## Server warnings and cautions

Before installing a server, be sure that you understand the following warnings and cautions.



**WARNING:** To reduce the risk of electric shock or damage to the equipment:

- Do not disable the power cord grounding plug. The grounding plug is an important safety feature.
- Plug the power cord into a grounded (earthed) electrical outlet that is easily accessible at all times.
- Unplug the power cord from the power supply to disconnect power to the equipment.
- Do not route the power cord where it can be walked on or pinched by items placed against it. Pay particular attention to the plug, electrical outlet, and the point where the cord extends from the server.



**WARNING:** To reduce the risk of personal injury from hot surfaces, allow the drives and the internal system components to cool before touching them.



**CAUTION:** Do not operate the server for long periods with the access panel open or removed. Operating the server in this manner results in improper airflow and improper cooling that can lead to thermal damage.

## Preparation procedures

To access some components and perform certain service procedures, you must perform one or both of the following procedures:

- Power down the server (on page 26).  
If you must remove a server from a rack or a non-hot-plug component from a server, then you must power down the server.
- Remove the server from the chassis (on page 26).  
If the rack environment, cabling configuration, or the server location in the rack creates unstable conditions, then remove the server from the chassis.

## Power up the server

To power up the server, press the Power On/Standby button.

# Power down the server

Before powering down the server for any upgrade or maintenance procedures, perform a backup of critical server data and programs.



---

**IMPORTANT:** When the server is in standby mode, auxiliary power is still being provided to the system.

---

To power down the server, use one of the following methods:

- Press and release the Power On/Standby button.  
This method initiates a controlled shutdown of applications and the OS before the server enters standby mode.
- Press and hold the Power On/Standby button for more than 4 seconds to force the server to enter standby mode.  
This method forces the server to enter standby mode without properly exiting applications and the OS. If an application stops responding, you can use this method to force a shutdown.
- Use a virtual power button selection through iLO 4.  
This method initiates a controlled remote shutdown of applications and the OS before the server enters standby mode.

Before proceeding, verify the server is in standby mode by observing that the system power LED is amber.

# Remove the server from the chassis



---

**WARNING:** This server is very heavy. To reduce the risk of personal injury or damage to the equipment:

- Observe local occupational health and safety requirements and guidelines for manual material handling.
  - Get help to lift and stabilize the product during installation or removal, especially when the product is not fastened to the rails. Hewlett Packard Enterprise recommends that a minimum of two people are required for all rack server installations. A third person may be required to help align the server if the server is installed higher than chest level.
  - Use caution when installing the server in or removing the server from the rack; it is unstable when not fastened to the rails.
- 

1. Power down the server (on page [26](#)).
2. Disconnect all peripheral cables and power cords.

3. Remove the server from the chassis.

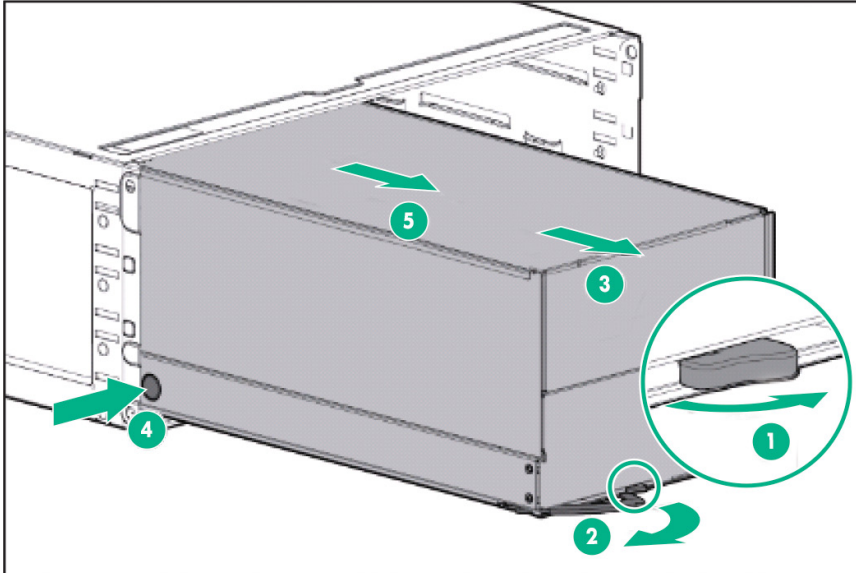

## Remove the hot-plug SFF drive cage

To remove the component:

1. Power down the server (on page 26).
2. Disconnect all peripheral cables from the server.
3. Remove the server from the chassis (on page 26).
4. Remove the front shipping plate ("[Remove the shipping brackets and shipping plates](#)" on page 27).
5. Disconnect the cables from the drive cage backplane.
6. Remove the hot-plug SFF drive cage.

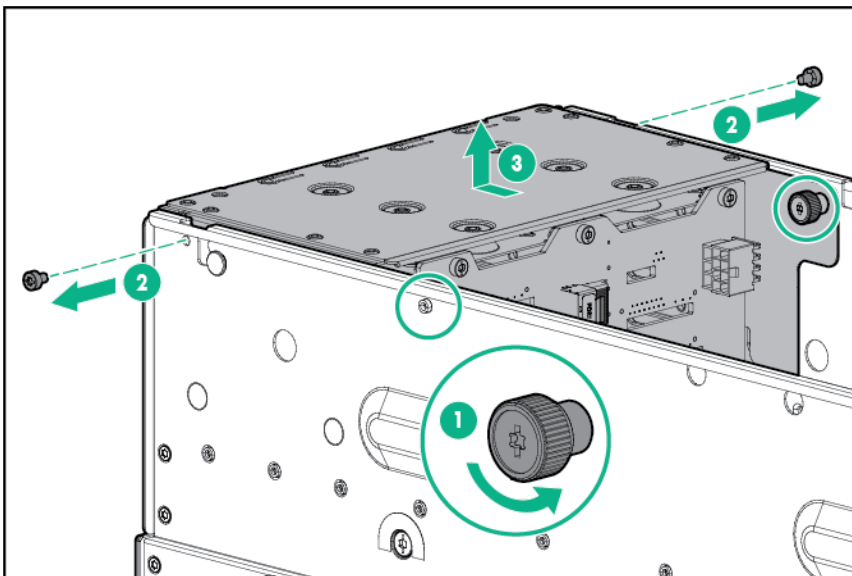

## Remove the shipping brackets and shipping plates

1. Power down the server (on page 26).
2. Disconnect all peripheral cables from the server.

3. Remove the server from the chassis (on page 26).
4. Remove the shipping brackets.

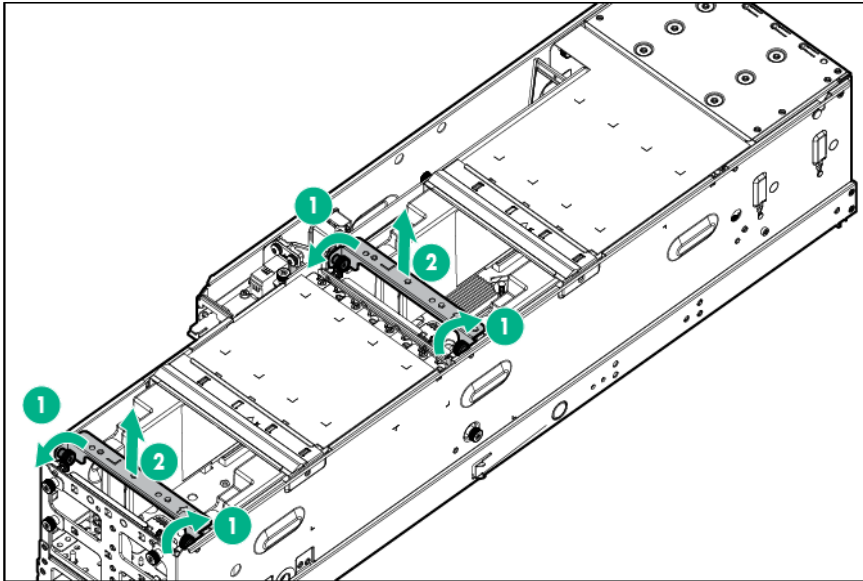

5. Remove the shipping plates.

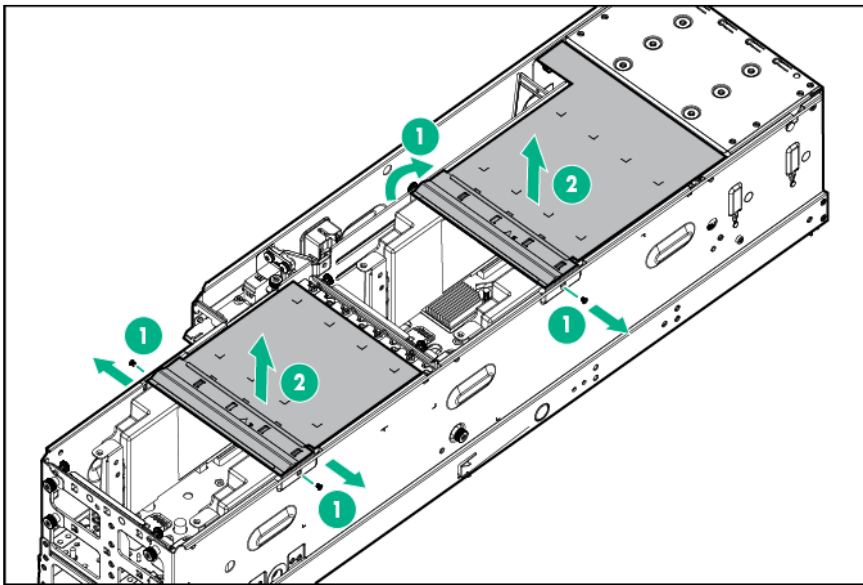

## Remove the PCI/FlexibleLOM riser cage

1. Power down the server (on page 26).
2. Disconnect all peripheral cables from the server.
3. Remove the server from the chassis (on page 26).
4. Remove the shipping brackets and shipping plates (on page 27).
5. Remove the SFF hot-plug drive cage ("[Remove the hot-plug SFF drive cage](#)" on page 27).
6. Remove the GPU cage (on page 29).
7. If an expansion board is installed, disconnect all cables connected to it.
8. Remove and/or loosen the screws securing the PCI/FlexibleLOM riser cage.
  - Remove the screws on the left node

— Loosen the thumbscrews on the right node

9. Lift the cage to unseat it from the system board:
  - o Left node

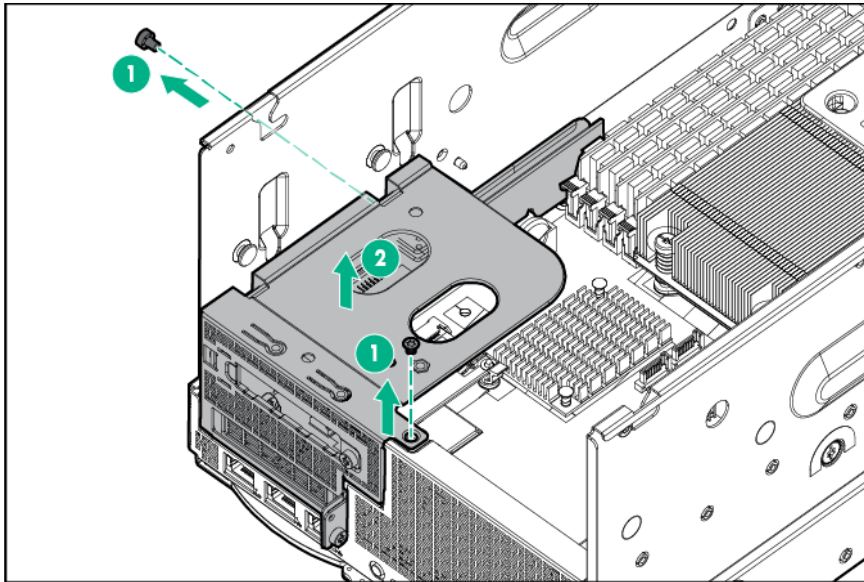

- o Right node

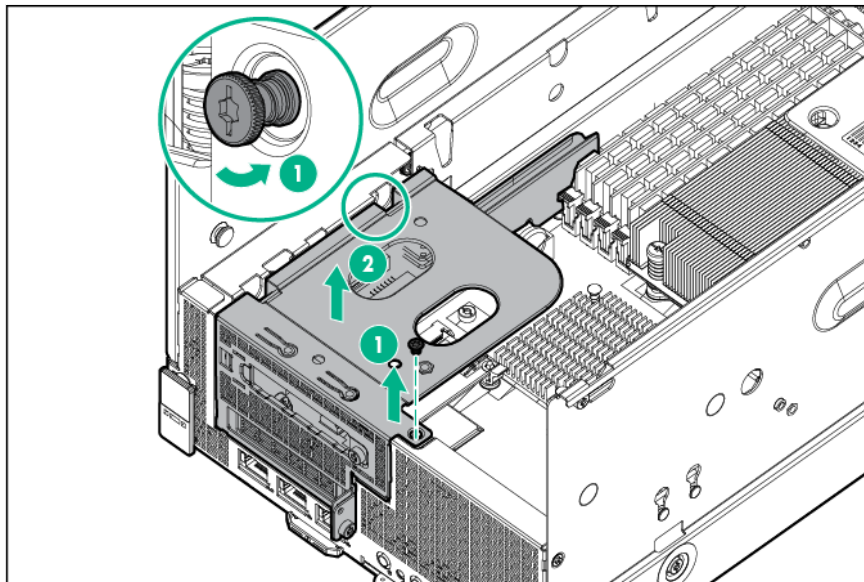

## Remove the GPU cage

1. Power down the server (on page 26).
2. Disconnect all peripheral cables from the server.
3. Remove the server from the chassis (on page 26).
4. Remove the shipping brackets and shipping plates (on page 27).
5. Remove the SFF hot-plug drive cage ("Remove the hot-plug SFF drive cage" on page 27).

6. Disconnect the GPU cage power cables from the L2 power board.

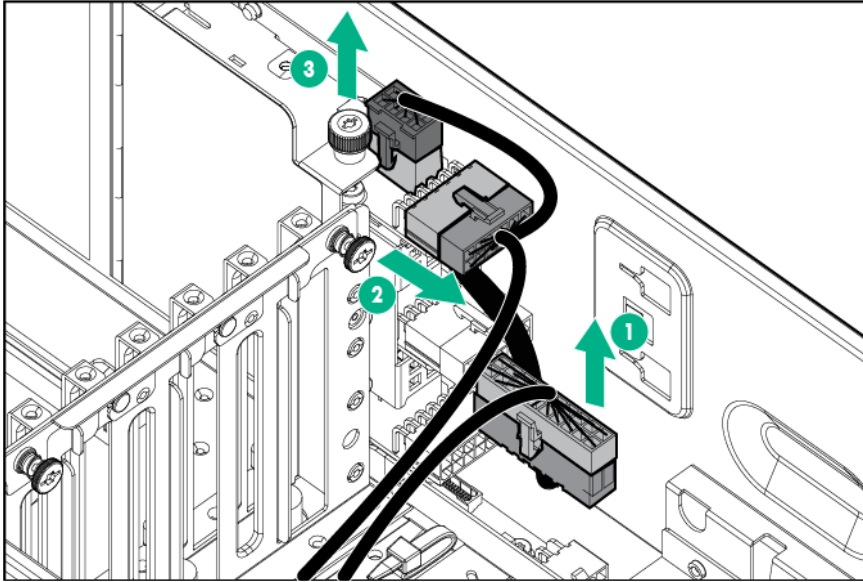

7. Loosen the screws securing the GPU cage.

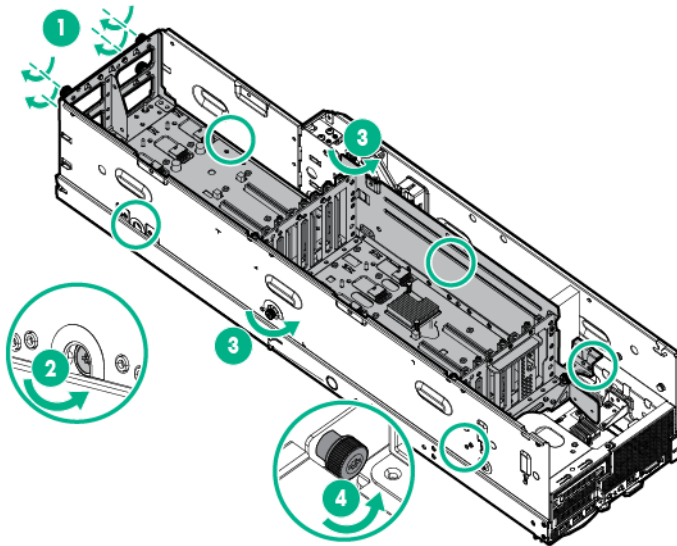

8. Remove the GPU cage.

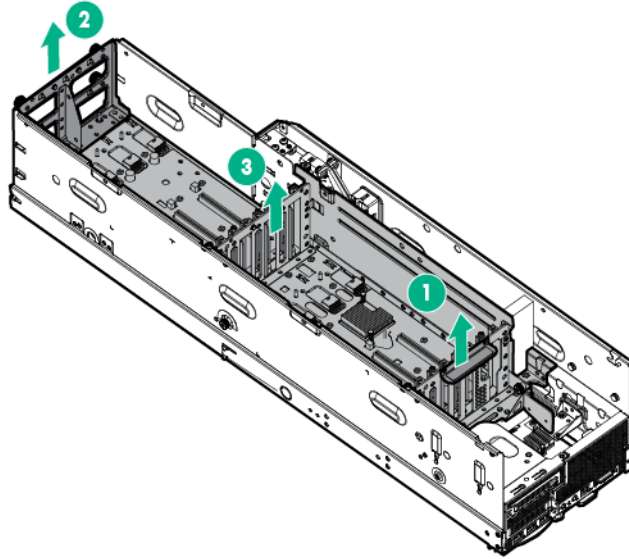

9. Disconnect the power cable located beneath the GPU cage.

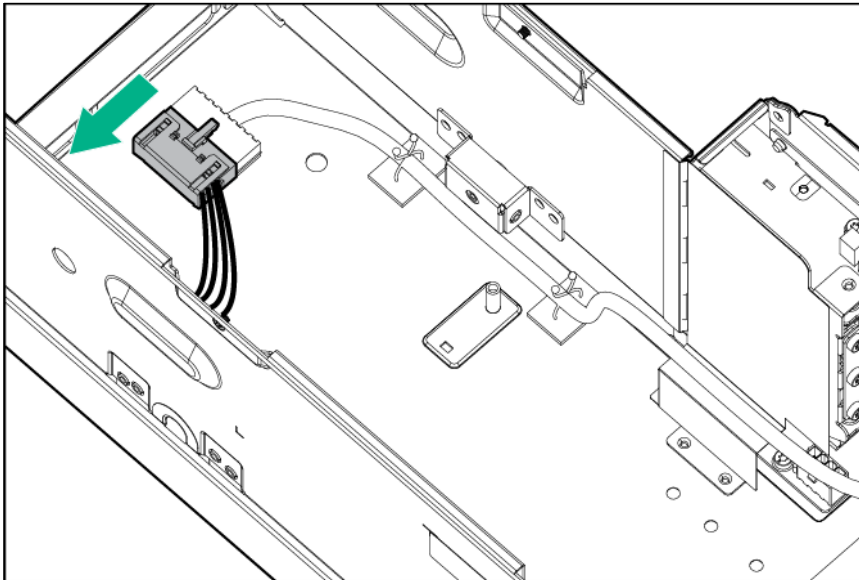

**IMPORTANT:** To avoid damage to the power connectors, lift the front and back of the GPU shelf simultaneously, maintaining a level orientation.

## Drive blank



**CAUTION:** To prevent improper cooling and thermal damage, do not operate the server unless all bays are populated with either a component or a blank.

Remove the drive blank.

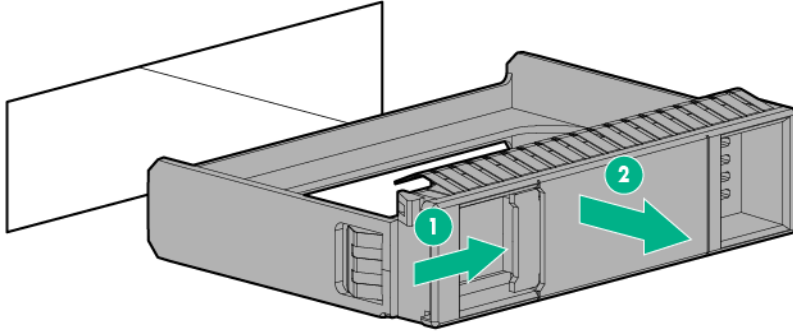

To replace the LFF drive blank, slide the component into the bay until it clicks.

To replace the SFF drive blank, while pressing the release latch, slide the component into the bay until it is fully seated.

## Hot-plug drive

To remove the component:

1. Determine the status of the drive from the drive LED definitions ("[Hot-plug drive LED definitions](#)" on page 67).
2. Back up all server data on the drive.
3. Remove the drive.

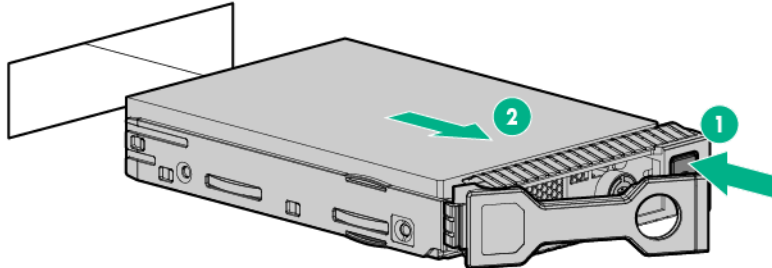

To replace the component:



**CAUTION:** To prevent improper cooling and thermal damage, do not operate the server or the enclosure unless all drive and device bays are populated with either a component or a blank.



1. Prepare the drive.

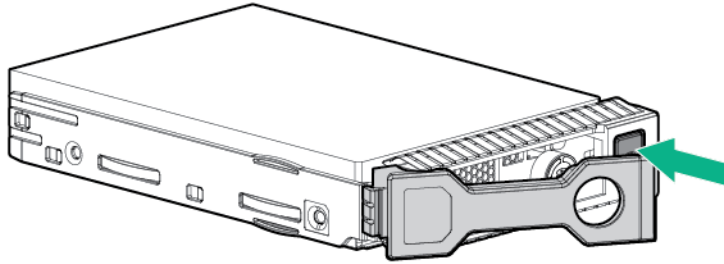

2. Install the drive.

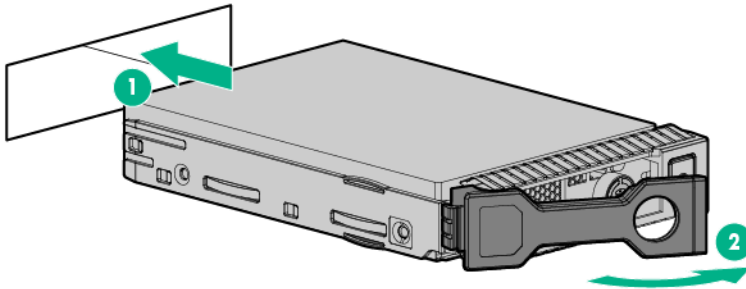

Determine the status of the drive from the drive LED definitions ("[Hot-plug drive LED definitions](#)" on page [67](#)).

## Hot-plug drive cage backplane

To remove the component:

1. Power down the server (on page [26](#)).
2. Disconnect all peripheral cables from the server.
3. Remove the server from the chassis (on page [26](#)).
4. Remove the shipping brackets and shipping plates (on page [27](#)).
5. Remove all cables connected to the drive backplane.
6. Remove the drive cage from the server ("[Remove the hot-plug SFF drive cage](#)" on page [27](#)).

7. Remove the drive cage backplane.

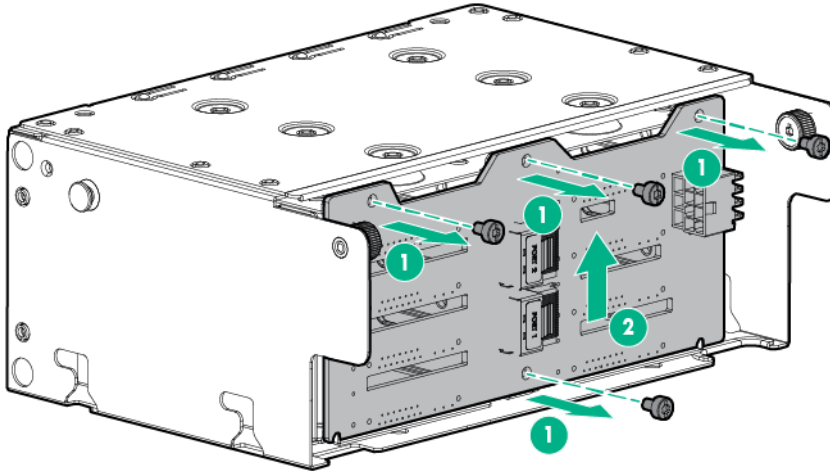

To replace the component, reverse the removal procedure.

## x32 riser board

To remove the component:

1. Power down the server (on page 26).
2. Disconnect all peripheral cables from the server.
3. Remove the server from the chassis (on page 26).
4. Remove the shipping brackets and shipping plates (on page 27).
5. Remove the SFF hot-plug drive cage ("[Remove the hot-plug SFF drive cage](#)" on page 27).
6. Remove the GPU cage (on page 29).
7. Remove the two screws securing the x32 riser board assembly to the system tray.
8. To release and remove the riser board assembly, pull the two blue handles at each end of the riser board assembly.

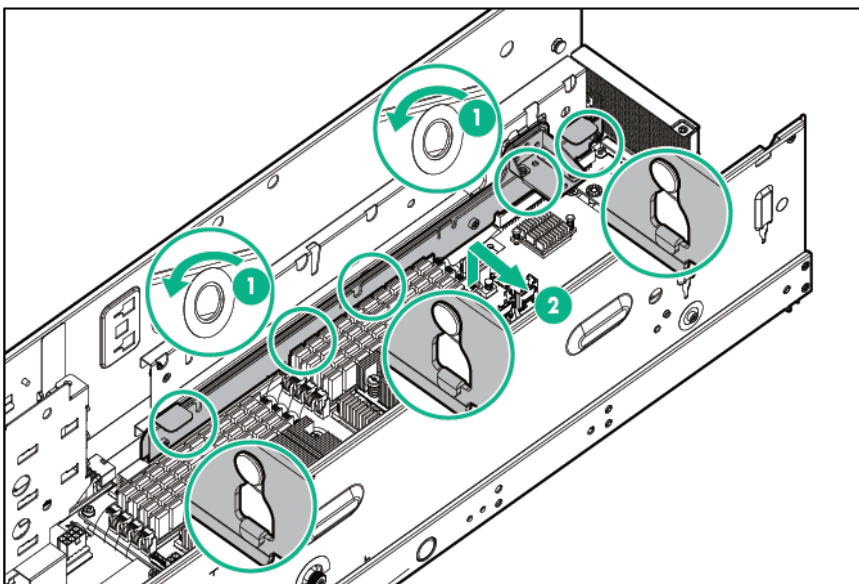

9. Remove the five screws securing the x32 riser board to the bracket.

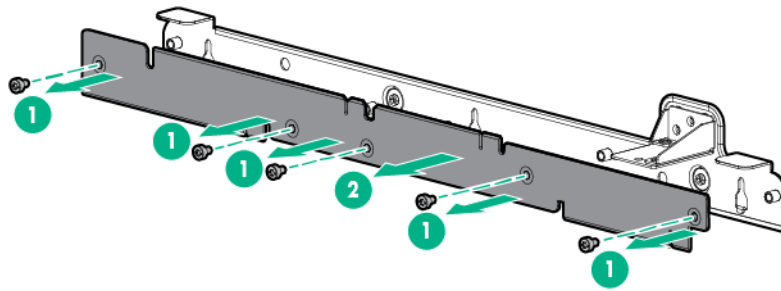

To replace the component, reverse the removal procedure.

## System battery

If the server no longer automatically displays the correct date and time, you might have to replace the battery that provides power to the real-time clock. Under normal use, battery life is 5 to 10 years.



**WARNING:** The computer contains an internal lithium manganese dioxide, a vanadium pentoxide, or an alkaline battery pack. A risk of fire and burns exists if the battery pack is not properly handled. To reduce the risk of personal injury:

- Do not attempt to recharge the battery.
- Do not expose the battery to temperatures higher than 60°C (140°F).
- Do not disassemble, crush, puncture, short external contacts, or dispose of in fire or water.
- Replace only with the spare designated for this product.

To remove the component:

1. Power down the server (on page 26).
2. Disconnect all peripheral cables from the server.
3. Remove the server from the chassis (on page 26).
4. Remove the shipping brackets and shipping plates (on page 27).
5. Remove the SFF hot-plug drive cage ("Remove the hot-plug SFF drive cage" on page 27).
6. Remove the GPU cage (on page 29).
7. Remove the PCI/FlexibleLOM riser cage (on page 28).
8. Locate the battery on the system board ("System board components" on page 63).

9. Remove the battery.

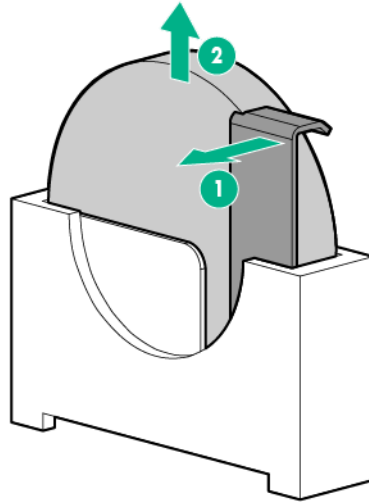

---

**IMPORTANT:** Replacing the system board battery resets the system ROM to its default configuration. After replacing the battery, reconfigure the system through RBSU.

---

To replace the component, reverse the removal procedure.

For more information about battery replacement or proper disposal, contact an authorized reseller or an authorized service provider.

## Flash-backed write cache procedures

The following types of procedures are provided for the FBWC option:

- Removing the capacitor pack ("FBWC capacitor pack" on page 36)
- Removing the capacitor pack holder ("FBWC capacitor pack holder" on page 37)



---

**CAUTION:** Do not detach the cable that connects the battery pack or capacitor pack to the cache module. Detaching the cable causes all data in the cache module to be lost.

---

## FBWC capacitor pack



---

**CAUTION:** To prevent a server malfunction or damage to the equipment, do not add or remove the battery pack while an array capacity expansion, RAID level migration, or stripe size migration is in progress.

---

To remove the component:

1. Power down the server (on page 26).
2. Disconnect all peripheral cables from the server.
3. Remove the server from the chassis (on page 26).
4. Remove the shipping brackets and shipping plates (on page 27).
5. Remove the SFF hot-plug drive cage ("Remove the hot-plug SFF drive cage" on page 27).
6. Remove the GPU cage (on page 29).
7. Disconnect the capacitor pack cable from the FBWC module.

8. Remove the FBWC capacitor pack.

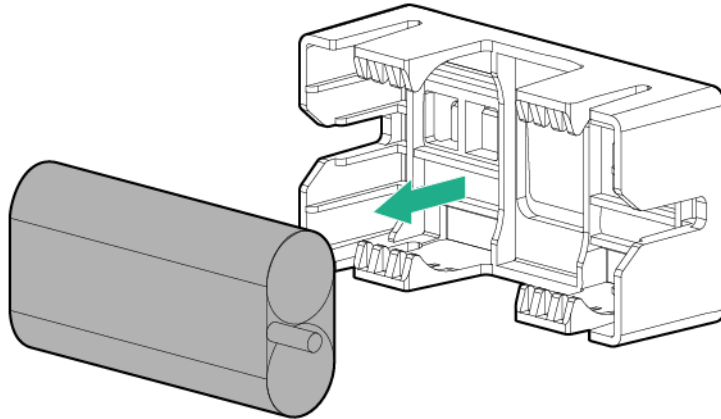

To replace the component, reverse the removal procedure.

## FBWC capacitor pack holder

---

**CAUTION:** To prevent a server malfunction or damage to the equipment, do not add or remove the battery pack while an array capacity expansion, RAID level migration, or stripe size migration is in progress.

---

To remove the component:

1. Power down the server (on page 26).
2. Disconnect all peripheral cables from the server.
3. Remove the server from the chassis (on page 26).
4. Remove the shipping brackets and shipping plates (on page 27).
5. Remove the SFF hot-plug drive cage ("Remove the hot-plug SFF drive cage" on page 27).
6. Remove the GPU cage (on page 29).
7. If installed, remove the FBWC capacitor pack ("FBWC capacitor pack" on page 36).

8. Remove the FBWC capacitor pack holder.

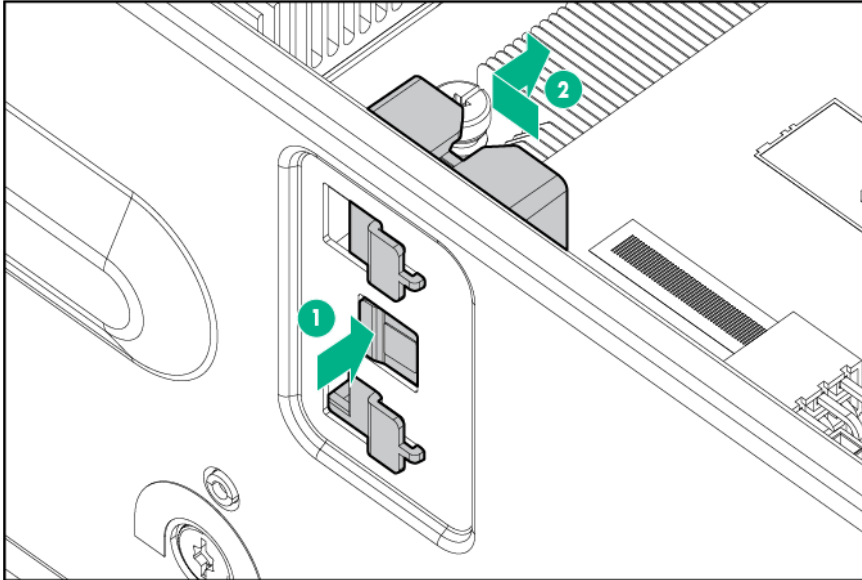

To replace the component, reverse the removal procedure.

## PCIe/FlexibleLOM riser board

To remove the component:

1. Power down the server (on page 26).
2. Disconnect all peripheral cables from the server.
3. Remove the server from the chassis (on page 26).
4. Remove the shipping brackets and shipping plates (on page 27).
5. Remove the SFF hot-plug drive cage ("Remove the hot-plug SFF drive cage" on page 27).
6. Remove the GPU cage (on page 29).
7. Remove the PCI/FlexibleLOM riser cage (on page 28).
8. Remove any installed expansion boards. ("Expansion boards" on page 40)

9. Remove the PCIe/FlexibleLOM riser board.

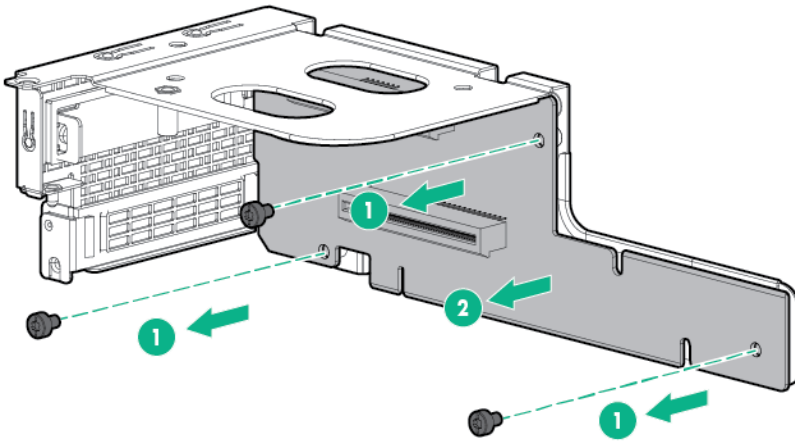

To replace the component, reverse the removal procedure.

## GPU module or blank

To remove the component:

1. Power down the server (on page 26).
2. Disconnect all peripheral cables from the server.
3. Remove the server from the chassis (on page 26).
4. Remove the shipping brackets and shipping plates (on page 27).
5. Remove the GPU power cable from the module.
6. Remove the GPU module or blank:
  - o GPU module

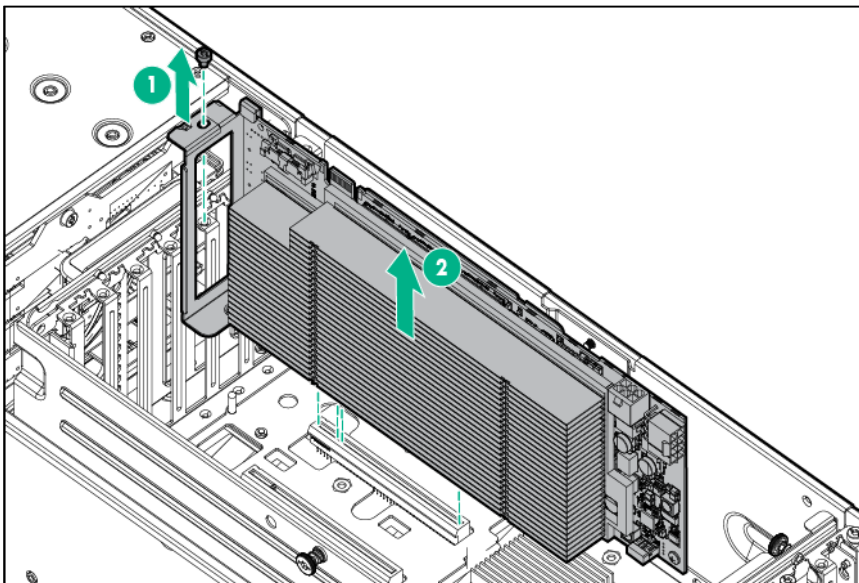

- o GPU blank

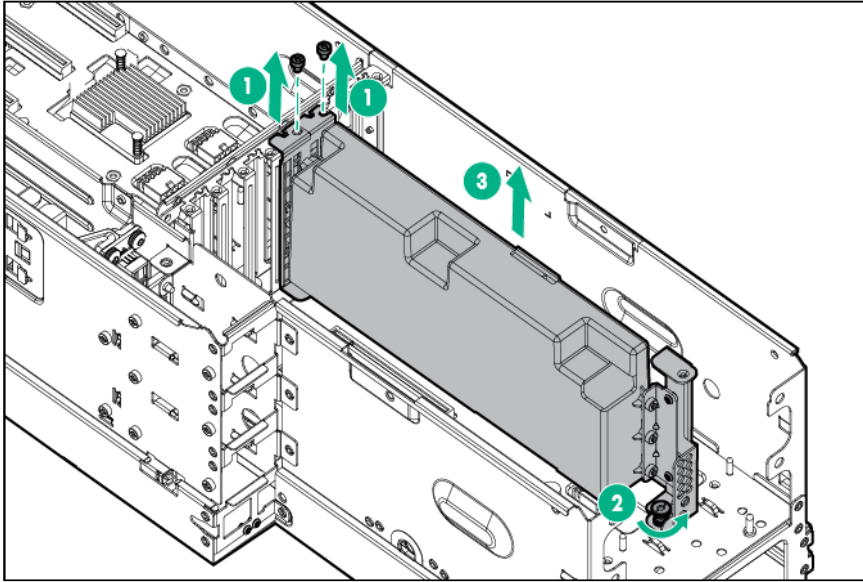

To replace the component, reverse the removal procedure.

## Expansion boards

To remove the component:

1. Power down the server (on page 26).
2. Disconnect all peripheral cables from the server.
3. Remove the server from the chassis (on page 26).
4. Remove the shipping brackets and shipping plates (on page 27).
5. Remove the SFF hot-plug drive cage ("Remove the hot-plug SFF drive cage" on page 27).
6. Remove the GPU cage (on page 29).
7. Remove the PCI/FlexibleLOM riser cage (on page 28).
8. Disconnect any cables connected to the expansion board.



9. Remove the expansion board.

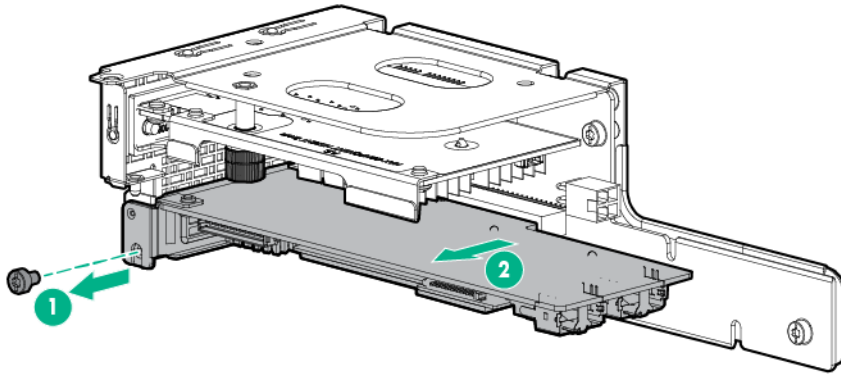

To replace the component, reverse the removal procedure.

## Mezzanine board

To remove the component:

1. Power down the server (on page 26).
2. Disconnect all peripheral cables from the server.
3. Remove the server from the chassis (on page 26).
4. Remove the shipping brackets and shipping plates (on page 27).
5. Remove the SFF hot-plug drive cage ("Remove the hot-plug SFF drive cage" on page 27).
6. Remove all GPU modules and blanks ("GPU module or blank" on page 39).
7. Remove the GPU cage (on page 29).
8. Disconnect the three power cables from the top of the mezzanine board, and then turn the GPU cage over.
9. Remove the mezzanine board:
  - a. Remove the six screws securing the metal shield.
  - b. Lift and remove the metal shield.
  - c. Remove the screws securing the mezzanine board to the GPU shelf.

d. Lift the mezzanine board.

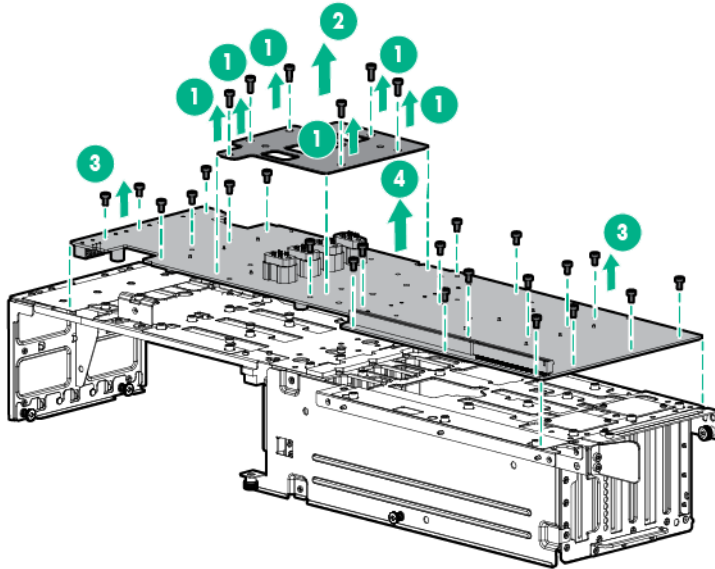

To replace the component, reverse the removal procedure.

## DIMMs

To remove the component:

1. Power down the server (on page 26).
2. Disconnect all peripheral cables from the server.
3. Remove the server from the chassis (on page 26).
4. Remove the shipping brackets and shipping plates (on page 27).
5. Remove the SFF hot-plug drive cage ("Remove the hot-plug SFF drive cage" on page 27).
6. Remove the GPU cage (on page 29).
7. Remove the processor air baffle ("Processor air baffle" on page 43).
8. Remove the DIMM.

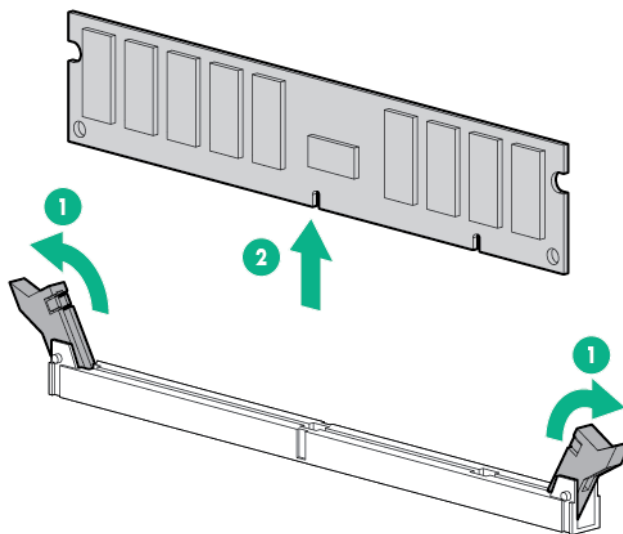

To replace the component, reverse the removal procedure.

## Processor air baffle

To remove the component:

1. Power down the server (on page 26).
2. Disconnect all peripheral cables from the server.
3. Remove the server from the chassis (on page 26).
4. Remove the shipping brackets and shipping plates (on page 27).
5. Remove the SFF hot-plug drive cage ("Remove the hot-plug SFF drive cage" on page 27).
6. Remove the GPU cage (on page 29).
7. Remove the processor air baffle.

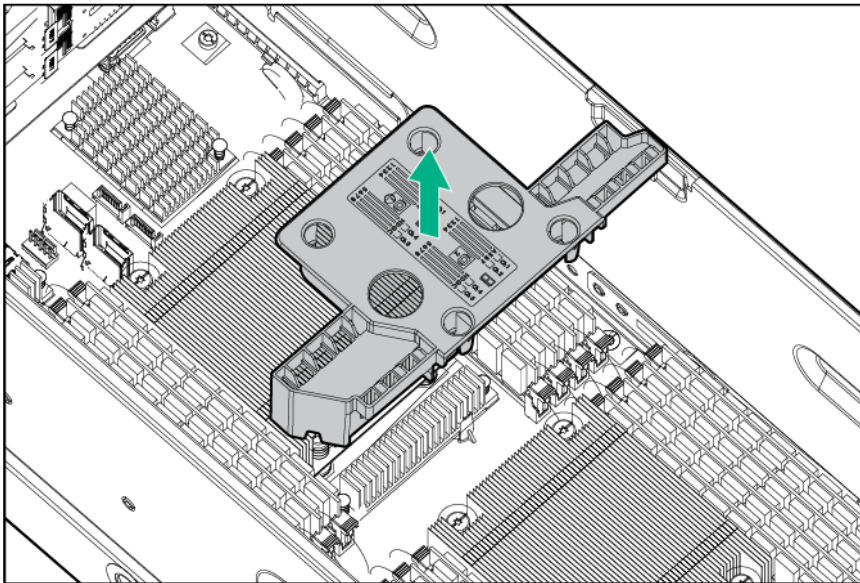

To replace the component, reverse the removal procedure.

## Heatsink

To remove the component:



**CAUTION:** The heatsink thermal interface media is not reusable and must be replaced if the heatsink is removed from the processor after it has been installed.



**CAUTION:** Heatsinks specified for processor 1 and 2 are not interchangeable. Be sure to note the appropriate orientation on the heatsink label.

1. Power down the server (on page 26).
2. Disconnect all peripheral cables from the server.
3. Remove the server from the chassis (on page 26).
4. Remove the shipping brackets and shipping plates (on page 27).
5. Remove the SFF hot-plug drive cage ("Remove the hot-plug SFF drive cage" on page 27).
6. Remove the GPU cage (on page 29).
7. Remove the processor air baffle ("Processor air baffle" on page 43).

8. Remove the heatsink.

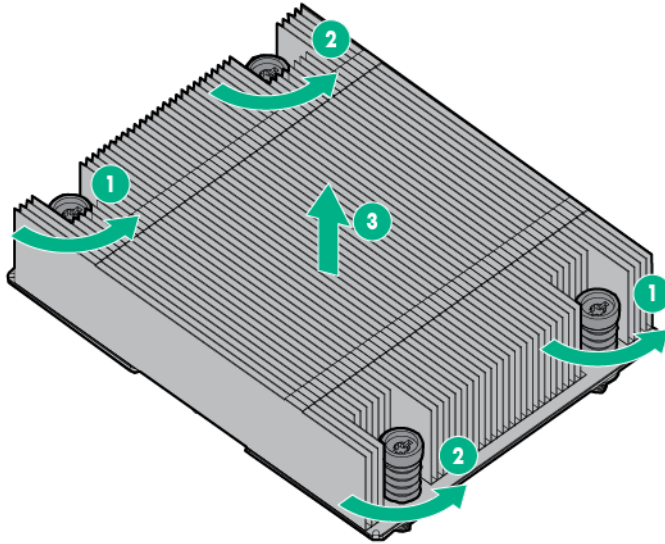

To replace the component:

1. Remove the thermal interface protective cover from the heatsink.

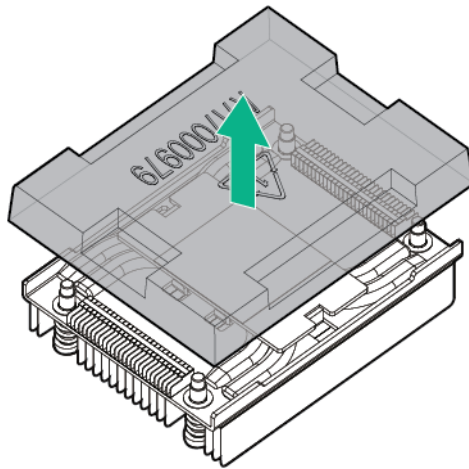

---

**CAUTION:** Heatsinks specified for processor 1 and 2 are not interchangeable. Be sure to note the appropriate orientation on the heatsink label.

---

**CAUTION:** Heatsink retaining screws should be tightened or loosened in diagonally opposite pairs (in an "X" pattern). Do not overtighten the screws as this can damage the board, connectors, or screws. Use the wrench supplied with the system to reduce the possibility of overtightening the screws.

---

2. Install the heatsink:
  - a. Position the heatsink on the processor backplate.
  - b. Tighten one pair of diagonally opposite screws halfway, and then tighten the other pair of screws.

- c. Finish the installation by completely tightening the screws in the same sequence.

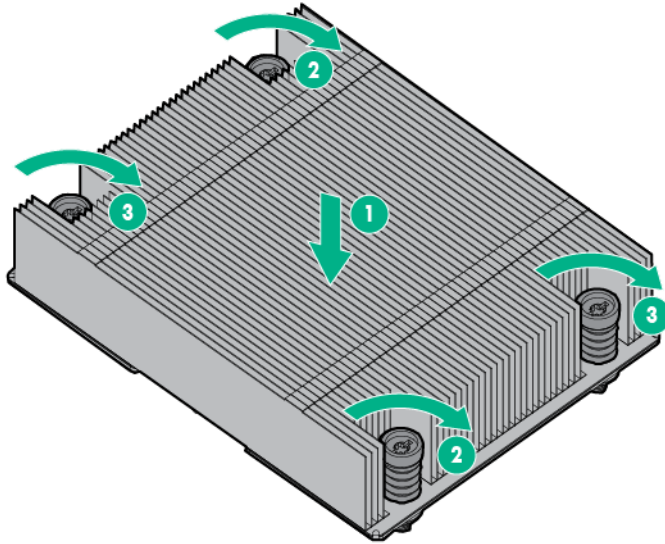

3. Install the processor air baffle.
4. Install the GPU cage
5. Install the SFF hot-plug drive cage.
6. Install the shipping brackets and shipping plates.
7. Install the server into the chassis.
8. Power up the server (on page 25).

## Processor



**WARNING:** To reduce the risk of personal injury from hot surfaces, allow the drives and the internal system components to cool before touching them.



**CAUTION:** To prevent possible server malfunction and damage to the equipment, multiprocessor configurations must contain processors with the same part number.



**CAUTION:** Heatsinks specified for processor 1 and 2 are not interchangeable. Be sure to note the appropriate orientation on the heatsink label.



**CAUTION:** To prevent possible server overheating, always populate processor socket 2 with a processor and a heatsink or a processor socket cover and a heatsink blank.



**IMPORTANT:** Processor socket 1 must be populated at all times or the server does not function.

To remove the component:

1. Power down the server (on page 26).
2. Disconnect all peripheral cables from the server.
3. Remove the server from the chassis (on page 26).
4. Remove the shipping brackets and shipping plates (on page 27).
5. Remove the SFF hot-plug drive cage ("Remove the hot-plug SFF drive cage" on page 27).

6. Remove the GPU cage (on page 29).
7. Remove the processor air baffle ("Processor air baffle" on page 43).
8. Remove the heatsink ("Heatsink" on page 43).
9. Open each of the processor locking levers in the order indicated, and then open the processor retaining bracket.

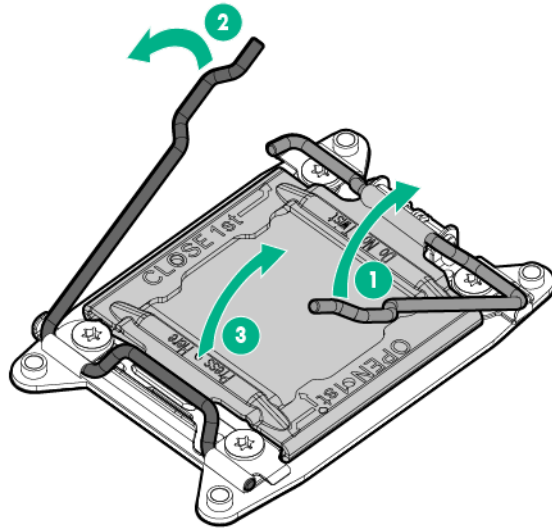

10. Remove the processor from the processor retaining bracket.

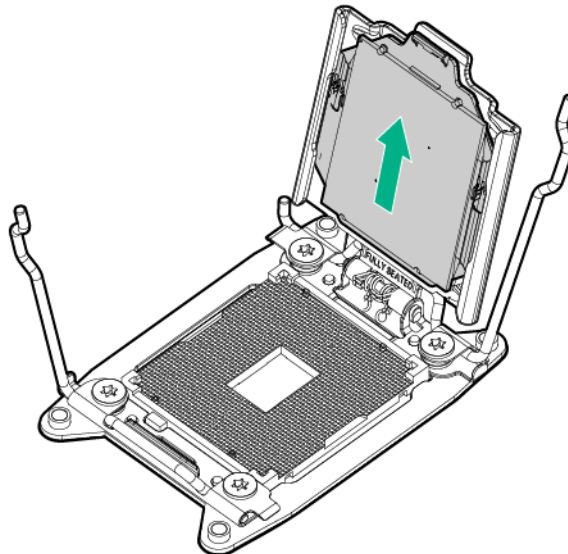

**CAUTION:** To avoid damage to the processor, do not touch the bottom of the processor, especially the contact area.

To install the processor:

1. Install the processor. Verify that the processor is fully seated in the processor retaining bracket by visually inspecting the processor installation guides on either side of the processor. **THE PINS ON THE SYSTEM BOARD ARE VERY FRAGILE AND EASILY DAMAGED.**

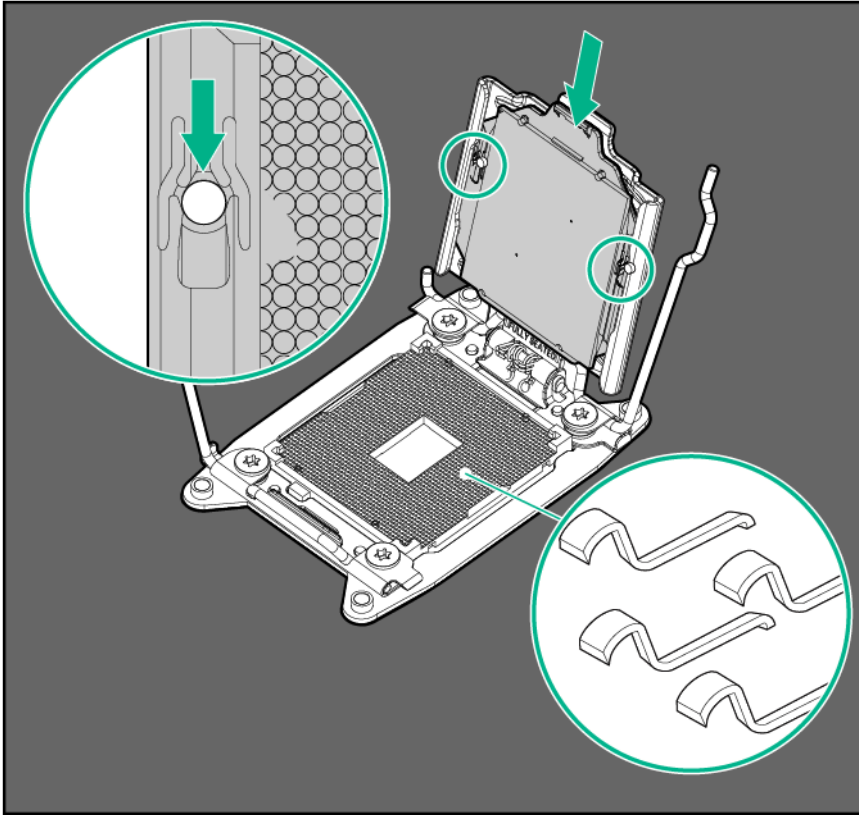

**⚠ CAUTION: THE PINS ON THE SYSTEM BOARD ARE VERY FRAGILE AND EASILY DAMAGED.** To avoid damage to the system board, do not touch the processor or the processor socket contacts.

2. Close the processor retaining bracket. When the processor is installed properly inside the processor retaining bracket, the processor retaining bracket clears the flange on the front of the socket.

**⚠ CAUTION:** Do not press down on the processor. Pressing down on the processor may cause damage to the processor socket and the system board. Press only in the area indicated on the processor retaining bracket.

3. Press and hold the processor retaining bracket in place, and then close each processor locking lever. Press only in the area indicated on the processor retaining bracket.

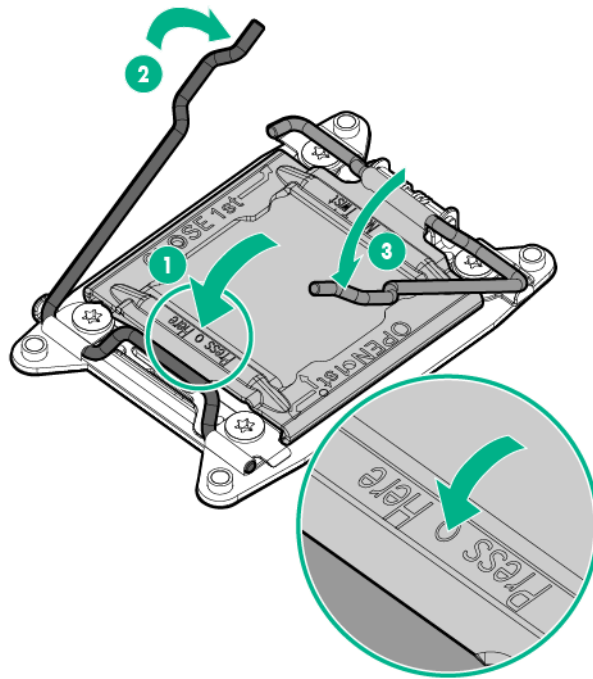

4. Clean the old thermal grease from the heatsink with the alcohol swab. Allow the alcohol to evaporate before continuing.
5. Apply all the grease to the top of the processor in the following pattern to ensure even distribution.

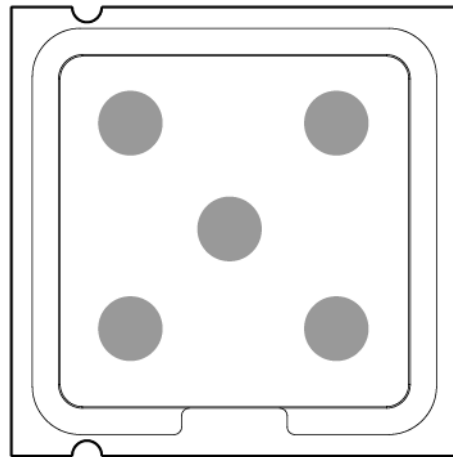

---

**CAUTION:** Heatsinks specified for processor 1 and 2 are not interchangeable. Be sure to note the appropriate orientation on the heatsink label.

---

**CAUTION:** Heatsink retaining screws should be tightened or loosened in diagonally opposite pairs (in an "X" pattern). Do not overtighten the screws as this can damage the board, connectors, or screws. Use the wrench supplied with the system to reduce the possibility of overtightening the screws.

---

6. Install the heatsink:



- a. Position the heatsink on the processor backplate.
- b. Tighten one pair of diagonally opposite screws halfway, and then tighten the other pair of screws.
- c. Finish the installation by completely tightening the screws in the same sequence.

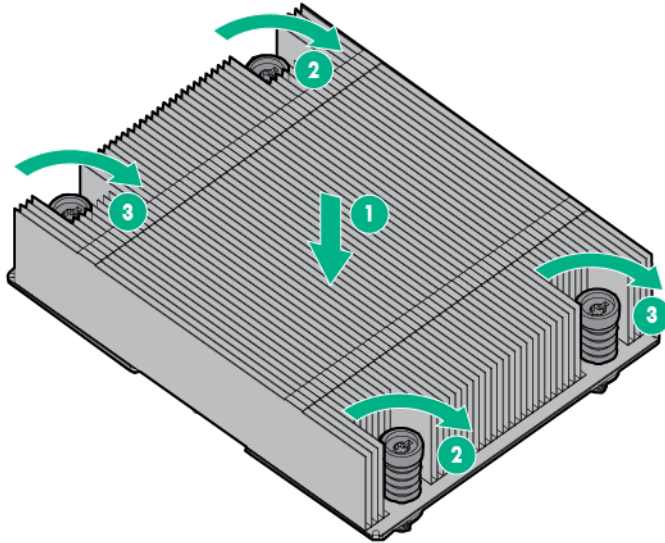

7. Install the processor air baffle.
8. Install the GPU cage
9. Install the SFF hot-plug drive cage.
10. Install the shipping brackets and shipping plates.
11. Install the server into the chassis.
12. Power up the server (on page 25).

## System board

To remove the component:

1. Power down the server (on page 26).
2. Disconnect all peripheral cables from the server.
3. Remove the server from the chassis (on page 26).
4. Remove the shipping brackets and shipping plates (on page 27).
5. Remove the SFF hot-plug drive cage ("Remove the hot-plug SFF drive cage" on page 27).
6. Remove the GPU cage (on page 29).
7. Disconnect all cables connected to the system board.
8. Remove the processor air baffle ("Processor air baffle" on page 43).
9. Remove all DIMMs ("DIMMs" on page 42).
10. Remove the heatsink.



**CAUTION:** The heatsink thermal interface media is not reusable and must be replaced if the heatsink is removed from the processor after it has been installed.



**CAUTION:** Heatsinks specified for processor 1 and 2 are not interchangeable. Be sure to note the appropriate orientation on the heatsink label.

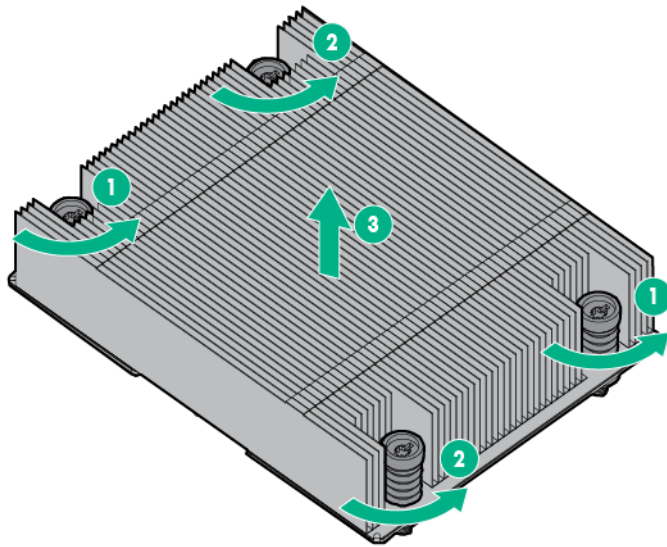

11. Open each of the processor locking levers in the order indicated, and then open the processor retaining bracket.

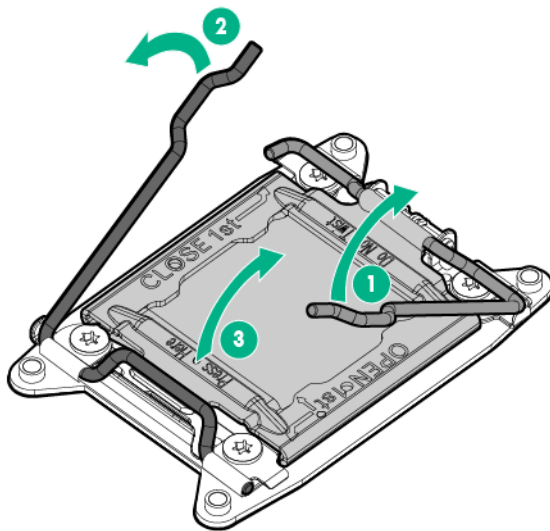

12. Remove the processor from the processor retaining bracket.

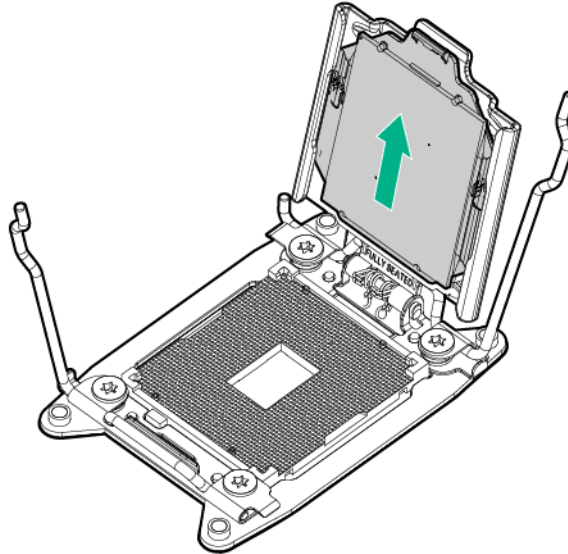

**CAUTION:** To avoid damage to the processor, do not touch the bottom of the processor, especially the contact area.

13. Remove the failed system board.

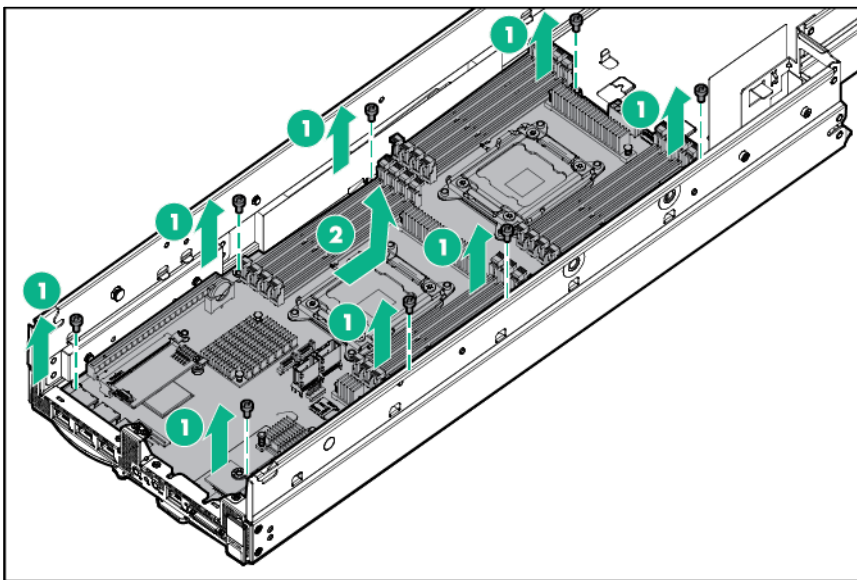

To replace the system board:

1. Align the system board on the tray, and then tighten the thumbscrews to secure it.

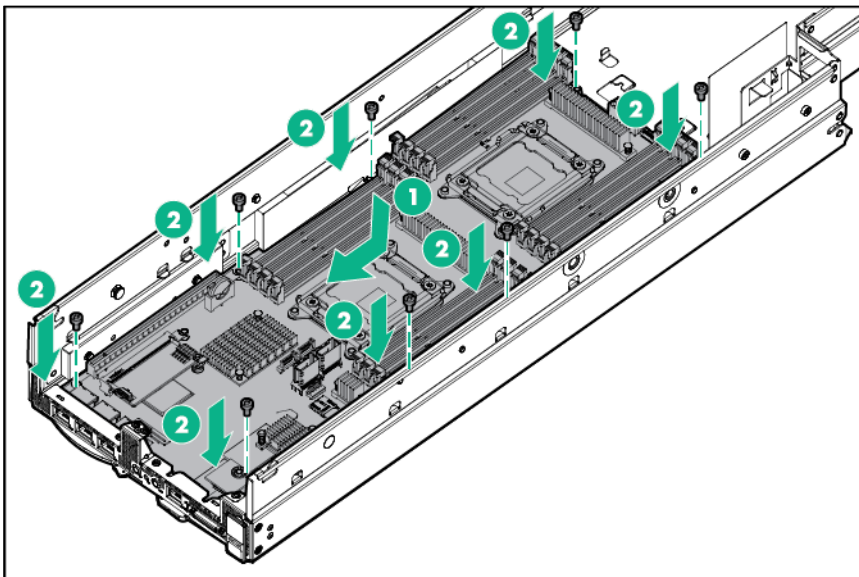

2. Open each of the processor locking levers in the order indicated, and then open the processor retaining bracket.

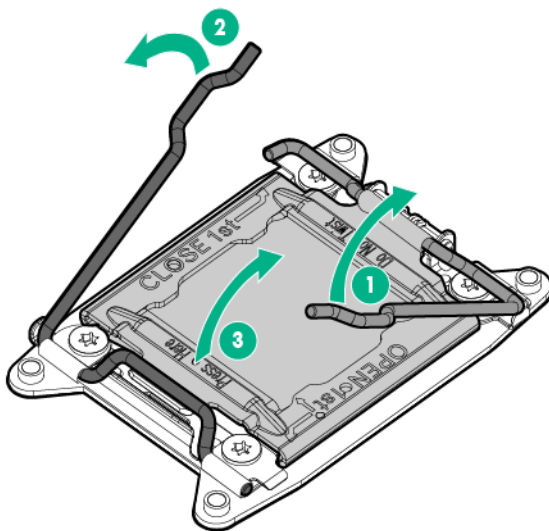

3. Remove the clear processor socket cover. Retain the processor socket cover for future use.

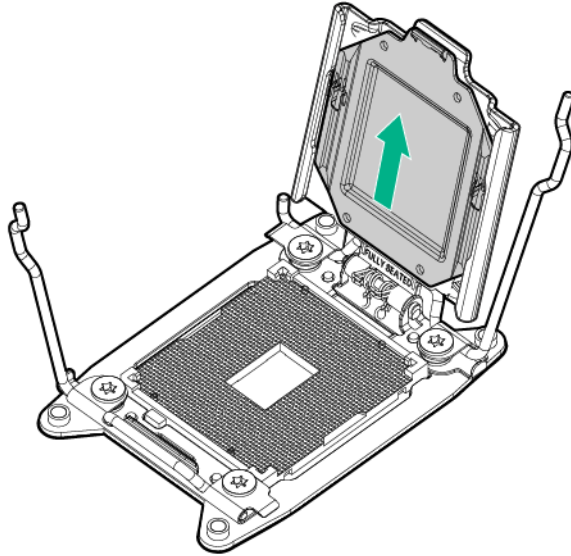

4. Install the processor. Verify that the processor is fully seated in the processor retaining bracket by visually inspecting the processor installation guides on either side of the processor. **THE PINS ON THE SYSTEM BOARD ARE VERY FRAGILE AND EASILY DAMAGED.**

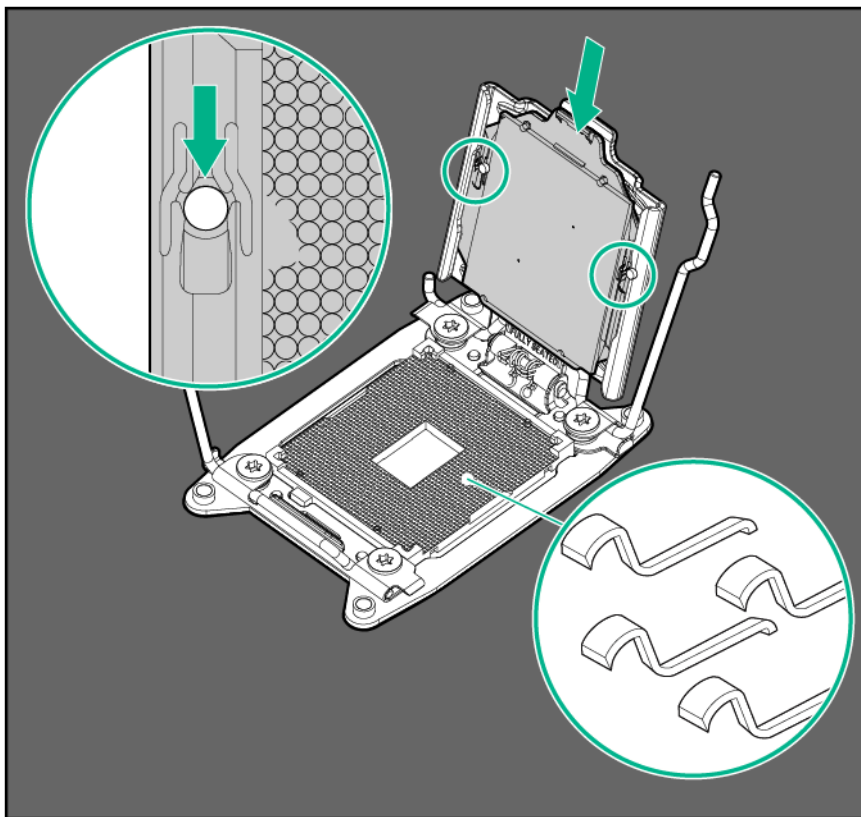

**CAUTION: THE PINS ON THE SYSTEM BOARD ARE VERY FRAGILE AND EASILY DAMAGED.** To avoid damage to the system board, do not touch the processor or the processor socket contacts.

5. Close the processor retaining bracket. When the processor is installed properly inside the processor retaining bracket, the processor retaining bracket clears the flange on the front of the socket.

**CAUTION:** Do not press down on the processor. Pressing down on the processor may cause damage to the processor socket and the system board. Press only in the area indicated on the processor retaining bracket.

6. Press and hold the processor retaining bracket in place, and then close each processor locking lever. Press only in the area indicated on the processor retaining bracket.

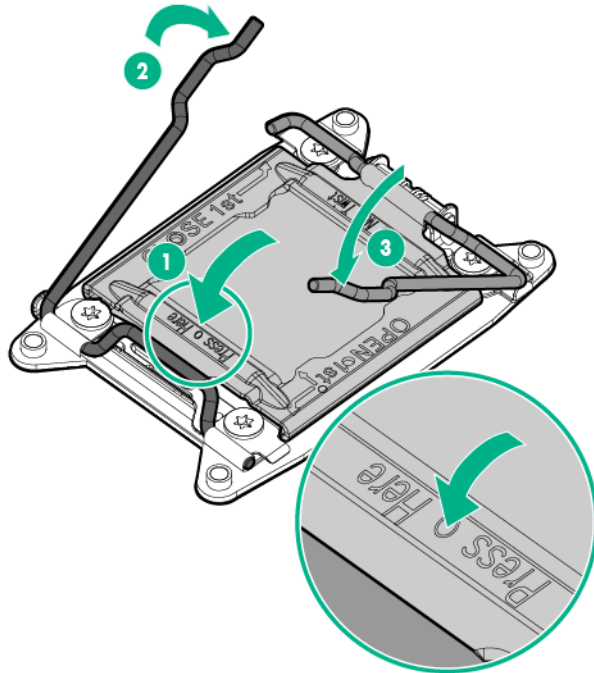

7. Clean the old thermal grease from the heatsink with the alcohol swab. Allow the alcohol to evaporate before continuing.
8. Apply all the grease to the top of the processor in the following pattern to ensure even distribution.

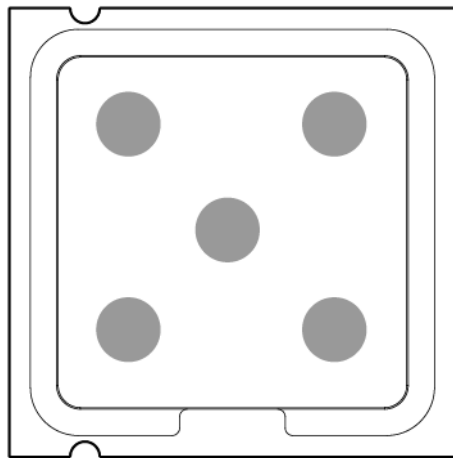

**CAUTION:** Heatsinks specified for processor 1 and 2 are not interchangeable. Be sure to note the appropriate orientation on the heatsink label.



**CAUTION:** Heatsink retaining screws should be tightened or loosened in diagonally opposite pairs (in an "X" pattern). Do not overtighten the screws as this can damage the board, connectors, or screws. Use the wrench supplied with the system to reduce the possibility of overtightening the screws.

9. Install the heatsink:
  - a. Position the heatsink on the processor backplate.
  - b. Tighten one pair of diagonally opposite screws halfway, and then tighten the other pair of screws.
  - c. Finish the installation by completely tightening the screws in the same sequence.

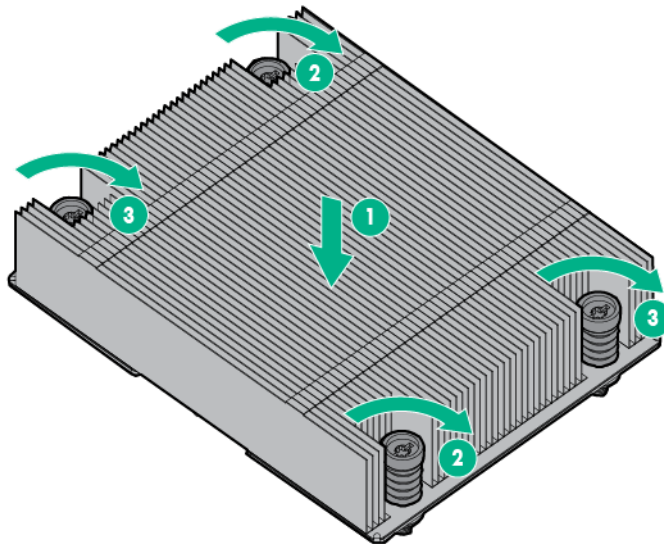

10. Install DIMMs.
11. Install the processor air baffle.
12. Connect cables to the system board.
13. Install the GPU cage
14. Install the SFF hot-plug drive cage.
15. Install the shipping brackets and shipping plates.
16. Install the server into the chassis.
17. Connect the peripheral cables.
18. Press the Power On/Standby button.
19. The server exits standby mode and applies full power to the system. The system power LED changes from amber to green.

## Re-entering the server serial number and product ID



**IMPORTANT:** When re-entering the serial number, be sure to use the server serial number. This number is located on the front panel serial number/iLO information pull tab. Do not use the chassis serial number.

After you replace the system board, you must re-enter the server serial number and the product ID.

1. During the server startup sequence, press the **F9** key to access RBSU.
2. Select the **Advanced Options** menu.
3. Select **Service Options**.

4. Select **Serial Number**. The following warning appears:  
Warning: The serial number should ONLY be modified by qualified service personnel. This value should always match the serial number located on the chassis.
5. Press the **Enter** key to clear the warning.
6. Enter the serial number and press the **Enter** key.
7. Select **Product ID**. The following warning appears:  
Warning: The Product ID should ONLY be modified by qualified service personnel. This value should always match the Product ID located on the chassis.
8. Enter the product ID and press the **Enter** key.
9. Press the **Esc** key to close the menu.
10. Press the **Esc** key to exit RBSU.
11. Press the **F10** key to confirm exiting RBSU. The server automatically reboots.

## Personality board

To remove the component:

1. Power down the server (on page 26).
2. Disconnect all peripheral cables from the server.
3. Remove the server from the chassis (on page 26).
4. Remove the shipping brackets and shipping plates (on page 27).
5. Remove the SFF hot-plug drive cage ("Remove the hot-plug SFF drive cage" on page 27).
6. Remove the GPU cage (on page 29).
7. Disconnect all cables connected to the personality board.
8. Remove the failed personality board.

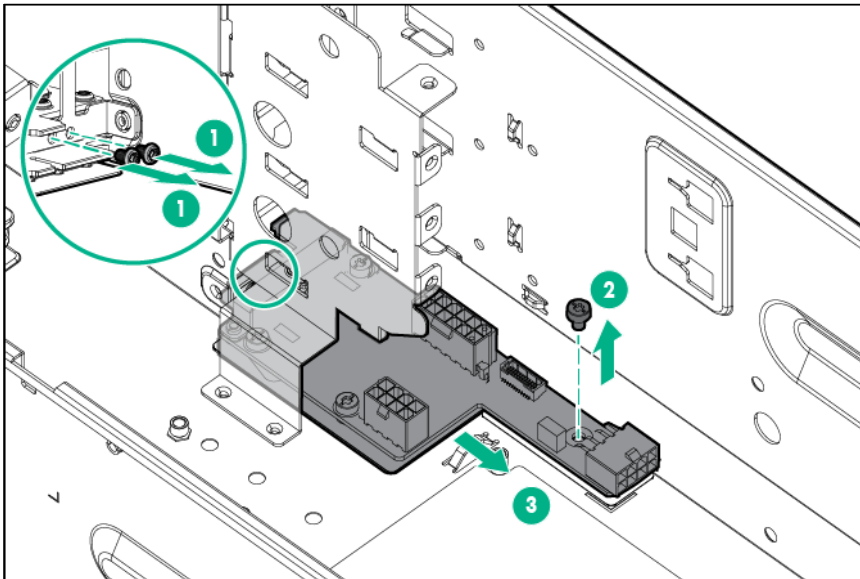

To replace the component, reverse the removal procedure.



# L2 power board

To remove the component:

1. Power down the server (on page 26).
2. Disconnect all peripheral cables from the server.
3. Remove the server from the chassis (on page 26).
4. Disconnect any power cables from the L2 power board.
5. Remove the two screws securing the L2 power board to the system tray.
6. Disconnect the power module, and slide the L2 power board out of the rear opening of the system tray.

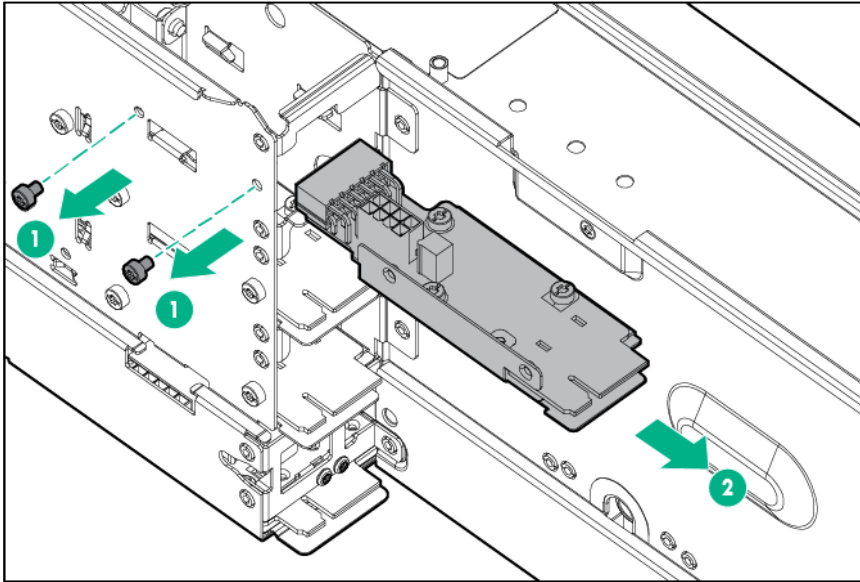

To replace the component, reverse the removal procedure.

# HP Trusted Platform Module

The TPM is not a customer-removable part.



**CAUTION:** Any attempt to remove an installed TPM from the system board breaks or disfigures the TPM security rivet. Upon locating a broken or disfigured rivet on an installed TPM, administrators should consider the system compromised and take appropriate measures to ensure the integrity of the system data.

If you suspect a TPM board failure, leave the TPM installed and remove the system board. Contact a Hewlett Packard Enterprise authorized service provider for a replacement system board and TPM board.

# Diagnostic tools

## Troubleshooting resources

The *ProLiant Gen8 Troubleshooting Guide, Volume I: Troubleshooting* provides procedures for resolving common problems and comprehensive courses of action for fault isolation and identification, issue resolution, and software maintenance on ProLiant servers and server blades. To view the guide, select a language:

- English ([http://www.hpe.com/support/Gen9\\_TSG\\_en](http://www.hpe.com/support/Gen9_TSG_en))
- French ([http://www.hpe.com/support/Gen9\\_TSG\\_fr](http://www.hpe.com/support/Gen9_TSG_fr))
- Spanish ([http://www.hpe.com/support/Gen9\\_TSG\\_es](http://www.hpe.com/support/Gen9_TSG_es))
- German ([http://www.hpe.com/support/Gen9\\_TSG\\_de](http://www.hpe.com/support/Gen9_TSG_de))
- Japanese ([http://www.hpe.com/support/Gen9\\_TSG\\_ja](http://www.hpe.com/support/Gen9_TSG_ja))
- Simplified Chinese ([http://www.hpe.com/support/Gen9\\_TSG\\_zh\\_cn](http://www.hpe.com/support/Gen9_TSG_zh_cn))

The *ProLiant Gen8 Troubleshooting Guide, Volume II: Error Messages* provides a list of error messages and information to assist with interpreting and resolving error messages on ProLiant servers and server blades. To view the guide, select a language:

- English ([http://www.hpe.com/support/Gen9\\_EMG\\_en](http://www.hpe.com/support/Gen9_EMG_en))
- French ([http://www.hpe.com/support/Gen9\\_EMG\\_fr](http://www.hpe.com/support/Gen9_EMG_fr))
- Spanish ([http://www.hpe.com/support/Gen9\\_EMG\\_es](http://www.hpe.com/support/Gen9_EMG_es))
- German ([http://www.hpe.com/support/Gen9\\_EMG\\_de](http://www.hpe.com/support/Gen9_EMG_de))
- Japanese ([http://www.hpe.com/support/Gen9\\_EMG\\_ja](http://www.hpe.com/support/Gen9_EMG_ja))
- Simplified Chinese ([http://www.hpe.com/support/Gen9\\_EMG\\_zh\\_cn](http://www.hpe.com/support/Gen9_EMG_zh_cn))

## HPE ROM-Based Setup Utility

RBSU is a configuration utility embedded in HPE ProLiant servers that performs a wide range of configuration activities that can include the following:

- Configuring system devices and installed options
- Enabling and disabling system features
- Displaying system information
- Selecting the primary boot controller
- Configuring memory options
- Language selection

For more information on RBSU, see the *HPE ROM-Based Setup Utility User Guide* on the RBSU Information Library (<http://www.hpe.com/info/rbsu/docs>).

# HPE Insight Diagnostics

The Insight Diagnostics is a proactive server management tool, available in both offline and online versions, that provides diagnostics and troubleshooting capabilities to assist IT administrators who verify server installations, troubleshoot problems, and perform repair validation.

The Insight Diagnostics Offline Edition performs various in-depth system and component testing while the OS is not running. To run this utility, boot the server using Intelligent Provisioning.

The Insight Diagnostics Online Edition is a web-based application that captures system configuration and other related data needed for effective server management. Available in Microsoft Windows and Linux versions, the utility helps to ensure proper system operation.

For more information or to download the utility, see the Hewlett Packard Enterprise website (<http://www.hpe.com/servers/diags>). The Insight Diagnostics Online Edition is also available in the SPP.

## Integrated Management Log

The IML records hundreds of events and stores them in an easy-to-view form. The IML timestamps each event with 1-minute granularity.

You can view recorded events in the IML in several ways, including the following:

- From within HPE SIM
- From within operating system-specific IML viewers:
  - For Windows: IML Viewer
  - For Linux: IML Viewer Application
- From within the iLO 4 web interface
- From within Insight Diagnostics ("[HPE Insight Diagnostics](#)" on page 59)

# Component identification

## Front panel components

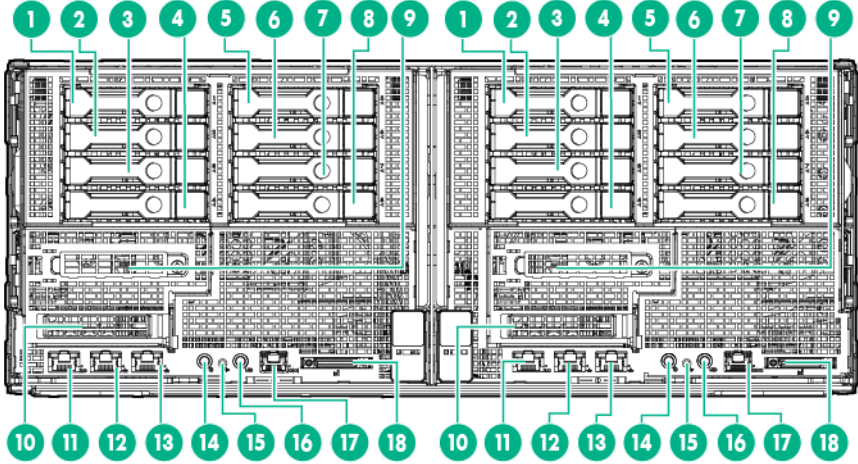

Item	Description
1	Hot-plug drive 1
2	Hot-plug drive 2
3	Hot-plug drive 3
4	Hot-plug drive 4
5	Hot-plug drive 5
6	Hot-plug drive 6
7	Hot-plug drive 7
8	Hot-plug drive 8
9	Option bay 2, FlexibleLOM
10	Option bay 1, PCI riser board
11	iLO 4 connector
12	NIC 2 connector
13	NIC 1 connector
14	Power On/Standby button and system power LED
15	Health LED
16	UID LED button
17	Serial connector
18	SUV connector

# Front panel LEDs and buttons

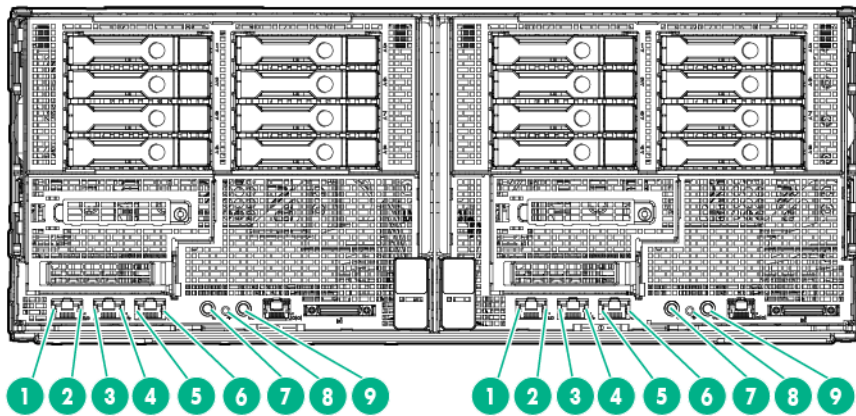

Item	Description	Status
1	iLO 4 speed LED	Green = LAN connection using a GbE link Amber = LAN connection using a 10 Mbps/100 Mbps link Off = No link exists
2	iLO 4 status LED	Solid green = Link to network Flashing green (1 Hz/cycle per sec) = Network active Off = No network activity
3	NIC 2 status LED	Solid green = Link to network Flashing green (1 Hz/cycle per sec) = Network active Off = No network activity
4	NIC 2 speed LED	Green = LAN connection using a GbE link Amber = LAN connection using a 10 Mbps/100 Mbps link Off = No link exists
5	NIC 1/iLO 4 status LED	Solid green = Link to network Flashing green (1 Hz/cycle per sec) = Network active Off = No network activity
6	NIC 1/iLO 4 speed LED	Green = LAN connection using a GbE link Amber = LAN connection using a 10 Mbps/100 Mbps link Off = No link exists
7	Power On/Standby button and system power LED	Solid green = System on Flashing green (1 Hz/cycle per sec) = Performing power on sequence Solid amber = System in standby Off = No power present**
8	Health LED	Solid green = Normal Flashing amber = System degraded Flashing red (1 Hz/cycle per sec) = System critical Fast-flashing red (4 Hz/cycles per sec) = Power fault*
9	UID button/LED	Solid blue = Activated Flashing blue (1 Hz/cycle per sec) = Remote management or firmware upgrade in progress Off = Deactivated

\* To identify components in a degraded or critical state, see the iLO/BIOS logs and the server troubleshooting guide.

\*\* Facility power is not present, power cord is not attached, no power supplies are installed, power supply failure has occurred, or the power button cable is disconnected.

# Rear panel components

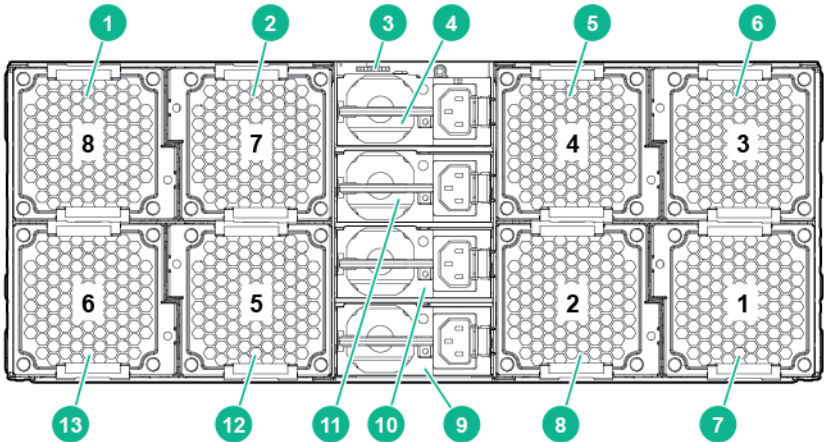

Item	Description
1	Fan 8
2	Fan 7
3	HPE APM interface
4	Power supply 4
5	Fan 4
6	Fan 3
7	Fan 1
8	Fan 2
9	Power supply 1
10	Power supply 2
11	Power supply 3
12	Fan 5
13	Fan 6

# Rear panel LEDs and buttons

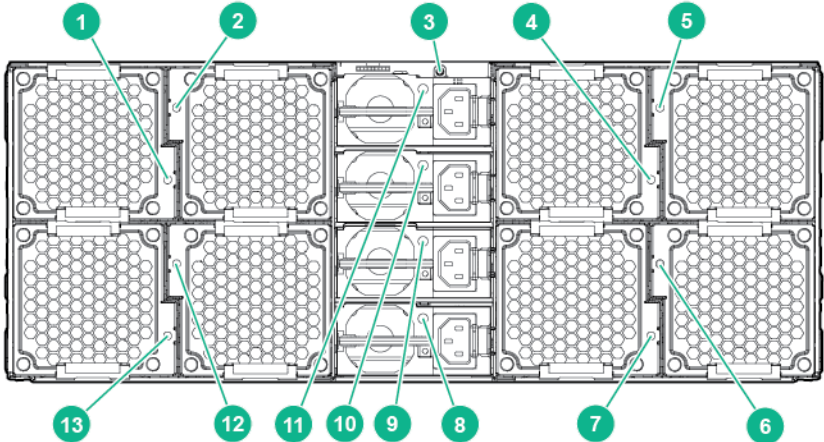

Item	Description	Status
1	Fan 8/16 power LED	Off—Normal Amber—Fan has failed.
2	Fan 7/15 power LED	Off—Normal Amber—Fan has failed.
3	UID LED button	Blue—Activated Flashing blue—System is being remotely managed. Off—Deactivated
4	Fan 4/12 power LED	Off—Normal Amber—Fan has failed.
5	Fan 3/11 power LED	Off—Normal Amber—Fan has failed.
6	Fan 1/9 power LED	Off—Normal Amber—Fan has failed.
7	Fan 2/10 power LED	Off—Normal Amber—Fan has failed.
8	Power supply 1 power LED	Green—Normal Off—No AC power
9	Power supply 2 power LED	Green—Normal Off—No AC power
10	Power supply 3 power LED	Green—Normal Off—No AC power
11	Power supply 4 power LED	Green—Normal Off—No AC power
12	Fan 5/13 power LED	Off—Normal Amber—Fan has failed.
13	Fan 6/14 power LED	Off—Normal Amber—Fan has failed.

## System board components

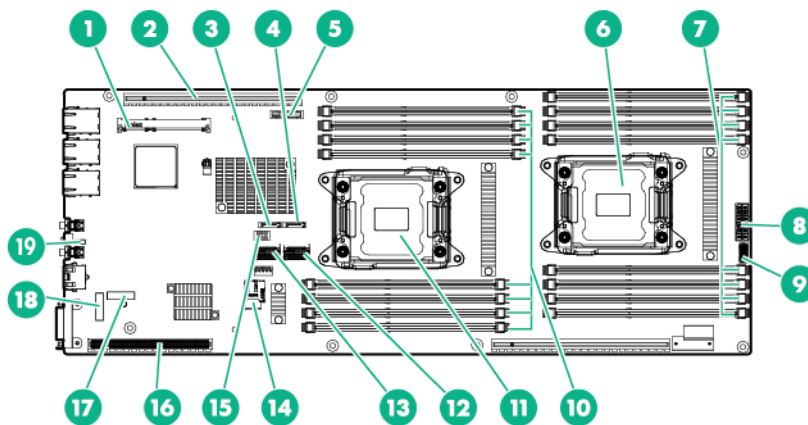

Item	Description
1	Cache module connector

Item	Description
2	PCIe x24 riser connector
3	SATA connector 2
4	SATA connector 1
5	System battery
6	Processor socket 2
7	Processor 2 DIMM slots
8	12-pin system board power connector
9	24-pin RPS connector
10	Processor 1 DIMM slots
11	Processor socket 1
12	Mini-SAS connector 2i
13	Mini-SAS connector 1i
14	microSD card slot
15	Hot-plug drive backplane sideband connector
16	FlexibleLOM x16 riser connector
17	System maintenance switch
18	TPM connector
19	NMI header

**NOTE:** This server supports PCIe Gen3 only in the FlexibleLOM slot. PCIe Gen2 is supported in all other slots.

## DIMM slot locations

DIMM slots are numbered sequentially (1 through 8) for each processor. The supported AMP modes use the alpha assignments for population order, and the slot numbers designate the DIMM slot ID for spare replacement.

The arrow points to the front of the server.

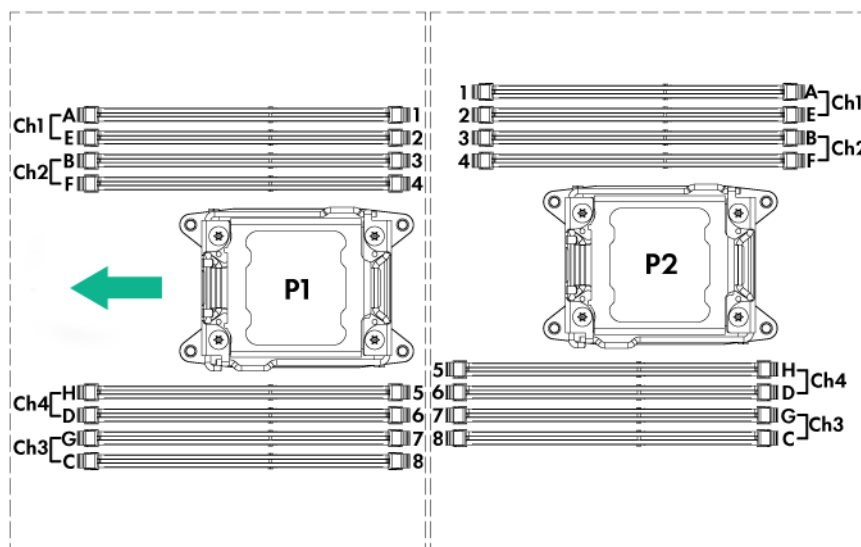



# System maintenance switch

Position	Default	Function
S1	Off	Off = iLO 4 security is enabled. On = iLO 4 security is disabled.
S2	Off	Off = System configuration can be changed. On = System configuration is locked.
S3	Off	Reserved
S4	Off	Reserved
S5	Off	Off = Power-on password is enabled. On = Power-on password is disabled.
S6	Off	Off = No function On = ROM reads system configuration as invalid.
S7	—	Reserved
S8	—	Reserved
S9	—	Off = PCIe 64-bit BAR function (large BAR) is disabled. On = PCIe 64-bit BAR function (large BAR) is enabled.
S10	—	Reserved
S11	—	Reserved
S12	—	Reserved

To access the redundant ROM, set S1, S5, and S6 to on.

When the system maintenance switch position 6 is set to the On position, the system is prepared to erase all system configuration settings from both CMOS and NVRAM.



**CAUTION:** Clearing CMOS and/or NVRAM deletes configuration information. Be sure to properly configure the server or data loss could occur.

## NMI functionality

An NMI crash dump creates a crash dump log before resetting a system which is not responding.

Crash dump log analysis is an essential part of diagnosing reliability problems, such as failures of operating systems, device drivers, and applications. Many crashes freeze a system, and the only available action for administrators is to restart the system. Resetting the system erases any information which could support problem analysis, but the NMI feature preserves that information by performing a memory dump before a system reset.

To force the system to invoke the NMI handler and generate a crash dump log, do one of the following:

- Use the iLO Virtual NMI feature.
- Short the NMI header ("[System board components](#)" on page 63).

For more information, see the Hewlett Packard Enterprise website (<http://www.hpe.com/support/NMI>).

# Drive numbering

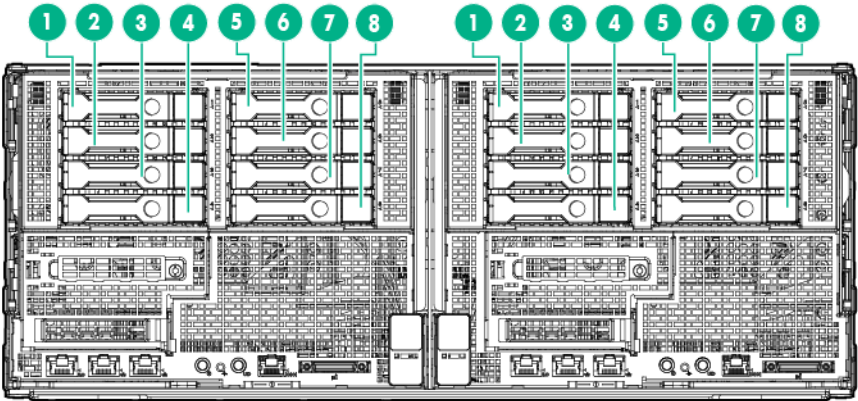

# GPU numbering

- Left node

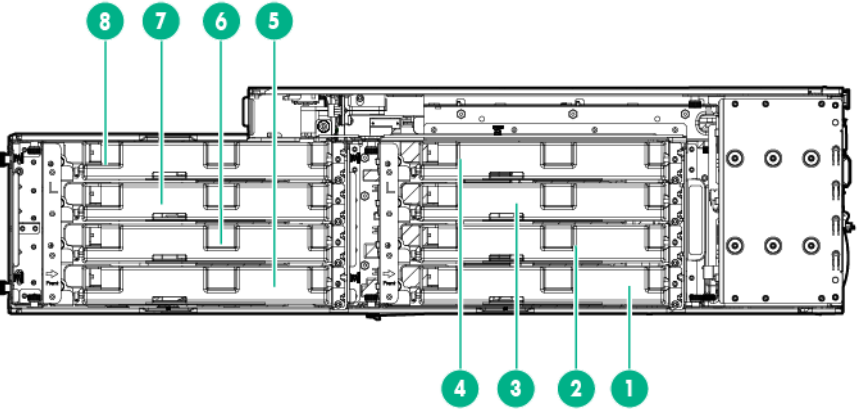

- Right node

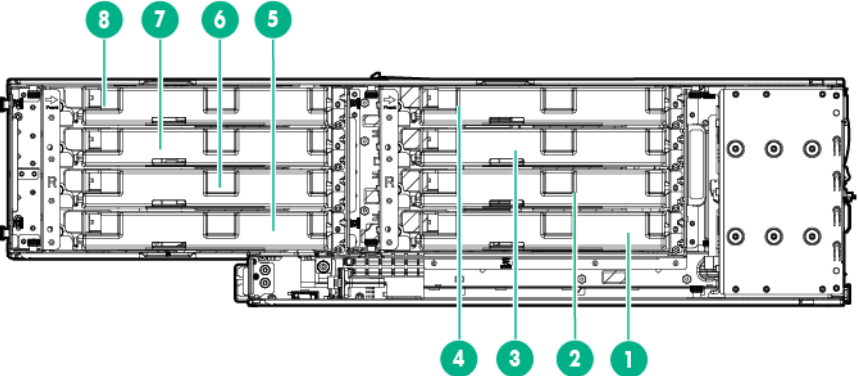

# Hot-plug drive LED definitions

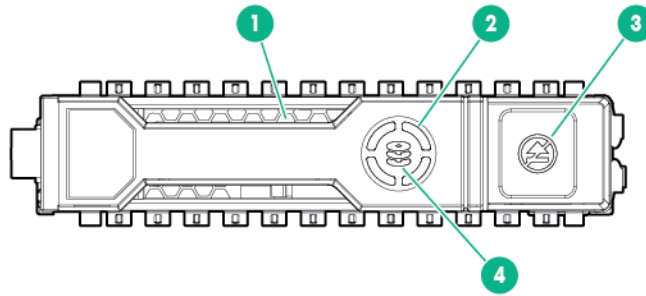

Item	LED	Status	Definition
1	Locate	Solid blue	The drive is being identified by a host application.
		Flashing blue	The drive carrier firmware is being updated or requires an update.
2	Activity ring	Rotating green	Drive activity
		Off	No drive activity
3	Do not remove	Solid white	Do not remove the drive. Removing the drive causes one or more of the logical drives to fail.
		Off	Removing the drive does not cause a logical drive to fail.
4	Drive status	Solid green	The drive is a member of one or more logical drives.
		Flashing green	The drive is rebuilding or performing a RAID migration, strip size migration, capacity expansion, or logical drive extension, or is erasing.
		Flashing amber/green	The drive is a member of one or more logical drives and predicts the drive will fail.
		Flashing amber	The drive is not configured and predicts the drive will fail.
		Solid amber	The drive has failed.
		Off	The drive is not configured by a RAID controller.

# Cabling

## Cabling overview

This section provides guidelines that help you make informed decisions about cabling the server and hardware options to optimize performance.

For information on cabling peripheral components, refer to the white paper on high-density deployment at the Hewlett Packard Enterprise website (<http://www.hpe.com/products/servers/platforms>).

**CAUTION:** When routing cables, always be sure that the cables are not in a position where they can be pinched or crimped.

## Personality board cabling

- Left node

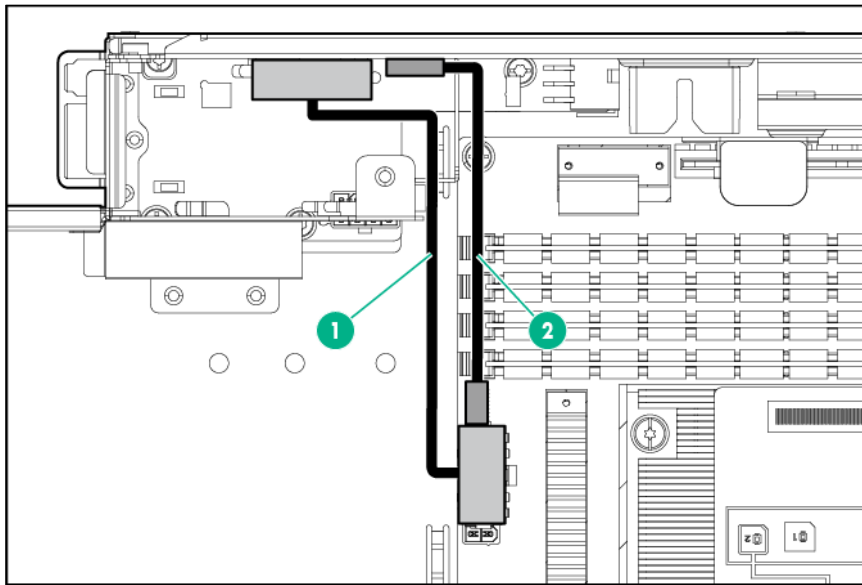

Item	Description
1	System board power cable
2	RPS cable

- Right node

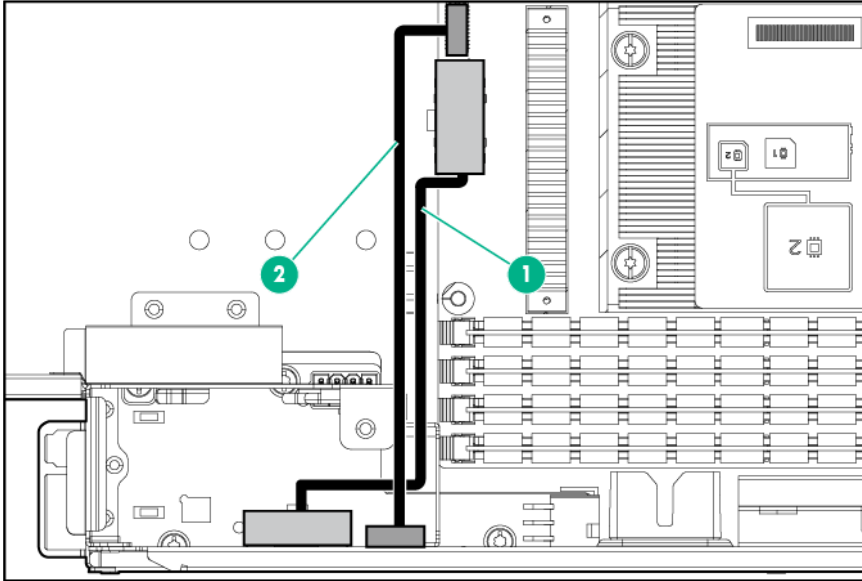

Item	Description
1	System board power cable
2	RPS cable

## FBWC capacitor pack cabling

- Left node

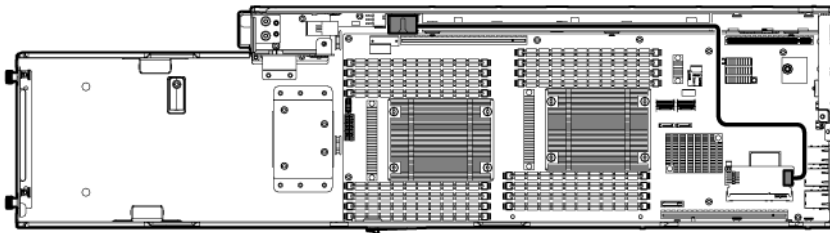

- Right node

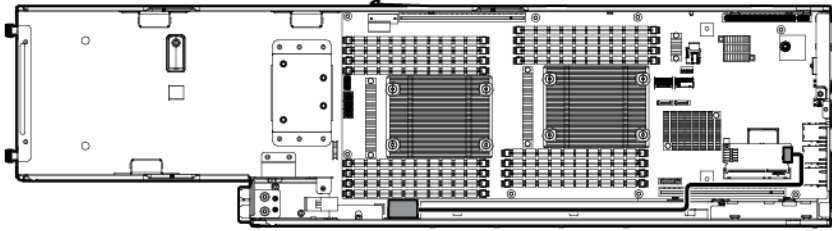

- Capacitor pack to FBWC on controller card cabling:
  - Left node

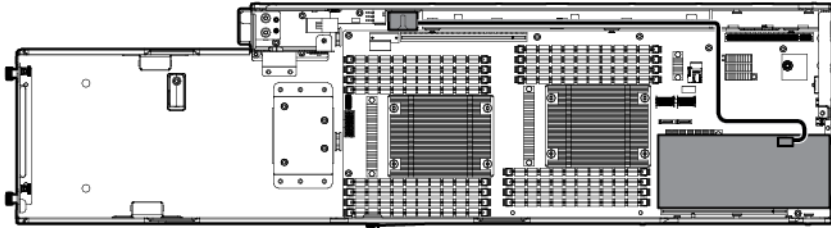

- Right node

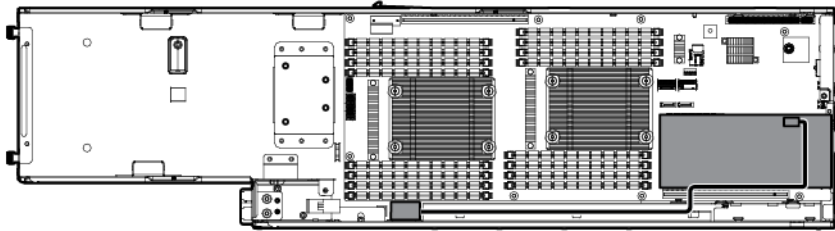

## Front drive cage cabling

- Front drive cabling to system board and power

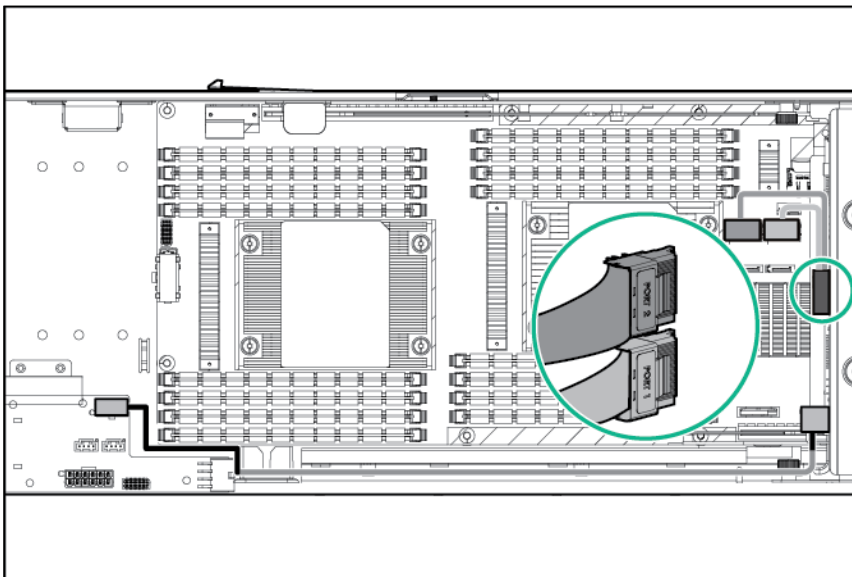

- Front drive cabling to controller card and power:

- Left node

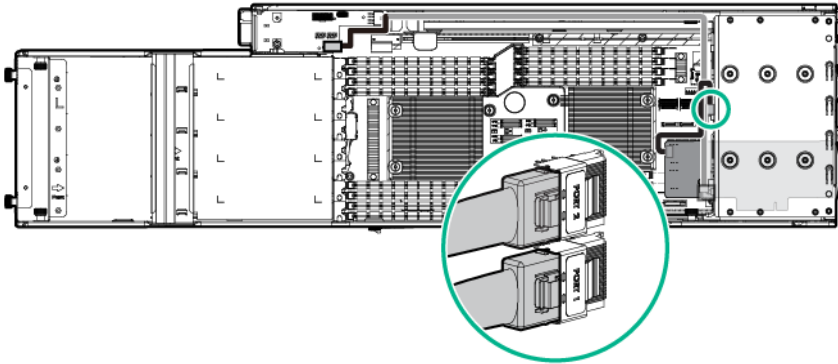

- Right node

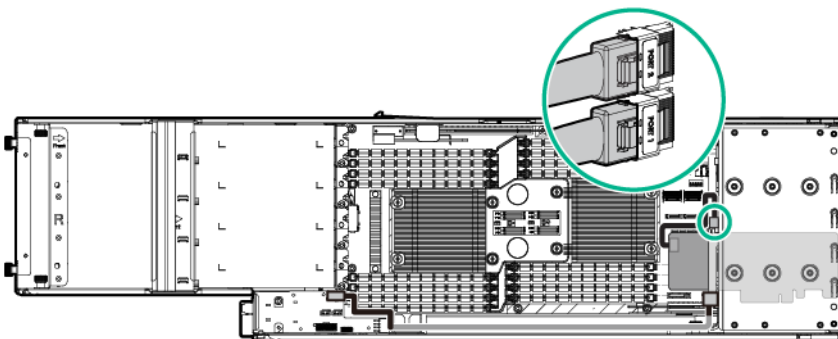

## GPU cabling

- GPU power cabling

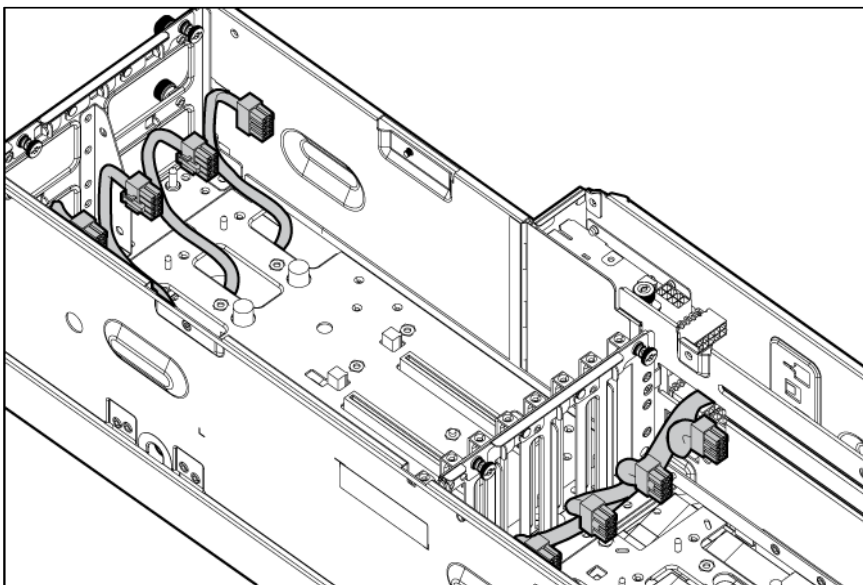



- GPU cage cabling

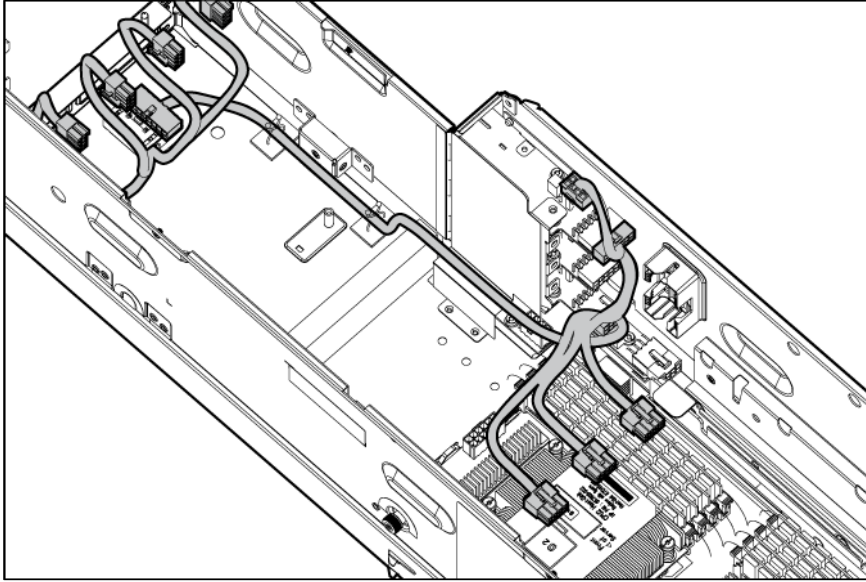

# Specifications

## Environmental specifications

Specification	Value
<b>Temperature range*</b>	—
Operating	10°C to 35°C (50°F to 95°F)
Shipping	-40°C to 70°C (-40°F to 158°F)
Maximum wet bulb temperature	28°C (82.4°F)
130 W CPU option	10°C to 25°C (50°F to 77°F)
<b>Relative humidity (noncondensing)**</b>	—
Operating	10% to 90%
Nonoperating	5% to 95%

\* All temperature ratings shown are for sea level. An altitude derating of 1°C per 300 m (1.8°F per 1,000 ft) to 3,048 m (10,000 ft) is applicable. No direct sunlight allowed.

\*\* Storage maximum humidity of 95% is based on a maximum temperature of 45°C (113°F). Altitude maximum for storage corresponds to a pressure minimum of 70 kPa.

## Server specifications

Specification	Value
Height	16.82 cm (6.62 in)
Depth	81.91 cm (32.25 in)
Width	22.08 cm (8.69 in)
Weight (maximum: two processors, eight hard drives)	21.32 kg (47.00 lb)

## Hot-plug power supply calculations

For hot-plug power supply specifications and calculators to determine electrical and heat loading for the server, see the Hewlett Packard Enterprise website (<http://www.hpe.com/info/hpepoweradvisor>).

# Acronyms and abbreviations

AMP

Advanced Memory Protection

CSR

Customer Self Repair

FBWC

flash-backed write cache

IEC

International Electrotechnical Commission

iLO

Integrated Lights-Out

IML

Integrated Management Log

LOM

Lights-Out Management

NMI

nonmaskable interrupt

NVRAM

nonvolatile memory

PCIe

Peripheral Component Interconnect Express

RBSU

ROM-Based Setup Utility

SAS

serial attached SCSI

SATA

serial ATA

**SD**

Secure Digital

**SFF**

small form factor

**SIM**

Systems Insight Manager

**SPP**

Service Pack for ProLiant

**TPM**

Trusted Platform Module

**UID**

unit identification

# Documentation feedback

Hewlett Packard Enterprise is committed to providing documentation that meets your needs. To help us improve the documentation, send any errors, suggestions, or comments to Documentation Feedback (<mailto:docsfeedback@hpe.com>). When submitting your feedback, include the document title, part number, edition, and publication date located on the front cover of the document. For online help content, include the product name, product version, help edition, and publication date located on the legal notices page.

# Index

## B

backplane, hard drive 33  
buttons 59, 61

## C

cables 67  
cabling 67, 68, 70, 71  
cache module 35  
capacitor pack 35  
capacitor pack cabling 68  
capacitor pack holder 36  
cautions 24, 25  
chassis, removing server 26  
components 15, 24, 59  
components, front panel 59  
components, identification 15, 59, 63  
components, rear panel 61  
components, system board 62  
connectors 59

## D

diagnostic tools 57, 58  
diagnostics utility 58  
DIMM slot locations 63  
DIMMs 41, 63  
DIMMs, removing 41  
documentation feedback 76  
drive blank 31  
drive cabling 67  
drive cage, removing 27  
drive LEDs 66  
drive numbering 65  
drive, replacing 32  
drives 32, 66  
drives, determining status of 66  
drives, removing 31, 32

## E

electrostatic discharge 24  
environmental requirements 73  
environmental specifications 73  
expansion board 39

## F

fan module location 61  
fans 61  
FBWC capacitor pack 35, 68

FBWC capacitor pack holder 36  
FBWC module 35  
features 59  
front panel buttons 60  
front panel components 59

## G

general diagnosis flowchart 60  
GPU blank, removing 38  
GPU cabling 71  
GPU numbering 65  
GPU shelf, removing 29  
grounding methods 24  
grounding requirements 24

## H

health LEDs 59  
heatsink 42  
Hewlett Packard Enterprise Technical Support 5  
hot-plug drive 32  
HPE Insight Diagnostics 24, 58

## I

iLO (Integrated Lights-Out) 58  
IML (Integrated Management Log) 58  
Insight Diagnostics 58  
Integrated Lights-Out (iLO) 58  
Integrated Management Log (IML) 58  
Intelligent Provisioning 58

## L

LEDs 61, 66  
LEDs, drive 66  
LEDs, front panel 60, 66  
LEDs, hard drive 66  
LEDs, power supply 61  
LEDs, rear panel 61  
LEDs, SAS hard drive 66  
LEDs, unit identification (UID) 61

## M

management tools 57  
mechanical components 15  
memory 63  
mezzanine boards, removing 40

## **N**

NMI functionality 64

## **P**

PCI riser cage 28  
PCIe riser board 37  
personality board 55, 67  
power module 55  
Power On button 25  
power requirements 73  
power supply 73  
power supply LEDs 61  
power up procedure 25  
powering down 26  
powering up 25  
preparation procedures 25  
problem diagnosis 57  
processor 44  
processor air baffle 42  
Product ID 54

## **R**

rack, extending server from 24  
RBSU (ROM-Based Setup Utility) 57  
rear components 61  
rear panel components 61  
rear panel connectors 61  
rear panel LEDs 61  
re-entering the server serial number 54  
removing server from chassis 26  
requirements, environmental 73  
requirements, power 73  
riser board 33  
ROM-Based Setup Utility (RBSU) 57

## **S**

safety considerations 24  
safety information 24  
SAS drives 15, 66  
serial number 54  
server, installation 26  
Service Pack for ProLiant 58  
shipping bracket, installing 27  
specifications 73  
SPP 58  
static electricity 24  
symbols on equipment 24  
system battery 34  
system board components 18, 62  
system components 59  
system maintenance switch 64

## **T**

technical support 5

temperature requirements 73  
TPM (Trusted Platform Module) 56  
TPM connector 62  
troubleshooting 57  
troubleshooting resources 57, 59, 67, 73  
Trusted Platform Module (TPM) 56

## **U**

UID LED 61  
utilities 57

## **W**

warnings 25