



Hewlett Packard
Enterprise

HPE ProLiant SL270s Gen8 SE Server

User Guide

Abstract

This document provides detailed instructions to configure and use the HPE ProLiant SL270s Gen8 SE Server.

Part Number: 743910-001R
November 2015
Edition: 2

© Copyright 2013, 2015 Hewlett Packard Enterprise Development LP

The information contained herein is subject to change without notice. The only warranties for Hewlett Packard Enterprise products and services are set forth in the express warranty statements accompanying such products and services. Nothing herein should be construed as constituting an additional warranty. Hewlett Packard Enterprise shall not be liable for technical or editorial errors or omissions contained herein.

Microsoft®, Windows®, and Windows Server® are either registered trademarks or trademarks of Microsoft Corporation in the United States and/or other countries.

Intel® Xeon® is a trademark of Intel Corporation in the U.S. and other countries.

Contents

Component identification	6
Front panel components.....	6
Front panel LEDs and buttons.....	7
Rear panel components	8
Rear panel LEDs and buttons	8
System board components.....	9
DIMM slot locations	10
System maintenance switch	11
NMI functionality	11
Drive numbering	12
GPU numbering.....	12
Hot-plug drive LED definitions.....	13
Operations	14
Power up the server	14
Power down the server.....	14
Remove the server from the chassis.....	14
Remove the hot-plug SFF drive cage.....	15
Install the hot-plug SFF drive cage.....	16
Remove the shipping brackets and shipping plates	16
Install the shipping brackets and shipping plates	18
Remove the GPU cage	19
Install the GPU cage	22
Remove the processor air baffle	23
Install the processor air baffle	23
Remove the PCI/FlexibleLOM riser cage	24
Install the PCI/FlexibleLOM riser cage	25
Setup.....	27
Optional services.....	27
Optimum environment.....	27
Space and airflow requirements	27
Temperature requirements	28
Electrical grounding requirements	28
Rack warnings.....	29
Contents of the server shipping carton.....	29
Installing the chassis	29
Installing the chassis components.....	29
Installing the server into the chassis	30
Powering up the chassis	31
Configuring the chassis	31
Powering on and selecting boot options.....	31
Installing the system software	31
Registering the server	32
Hardware options installation	33
Introduction.....	33
Connecting the SUV cable	33
Drive options	34
Drive installation guidelines	34
Installing a hot-plug drive.....	34
Controller options	35
Installing the FBWC module and capacitor pack.....	36
Expansion board or FlexibleLOM adapter option	39
Mini-SAS Y-cable option	41

GPU/coprocessor enablement options.....	44
Large BAR setting for coprocessor installation	44
GPU population rules	45
Coprocessor enablement option	46
GPU enablement option	50
Processor option	53
Memory options.....	57
HPE SmartMemory.....	57
Memory subsystem architecture.....	58
Single-, dual-, and quad-rank DIMMs.....	58
DIMM identification	59
Memory protection modes.....	59
General DIMM slot population guidelines.....	61
Installing a DIMM.....	62
HP Trusted Platform Module option	65
Installing the Trusted Platform Module board.....	66
Retaining the recovery key/password.....	69
Enabling the Trusted Platform Module	70
Cabling	71
Cabling overview	71
GPU cabling	71
Front drive cage cabling	72
FBWC capacitor pack cabling	73
Personality board cabling.....	75
Software and configuration utilities	77
Server mode.....	77
Hewlett Packard Enterprise product QuickSpecs.....	77
HPE iLO Management	77
HPE iLO.....	77
Intelligent Provisioning.....	79
HPE Insight Remote Support software.....	80
Insight Online.....	80
Scripting Toolkit for Windows and Linux.....	81
Service Pack for ProLiant.....	81
HP Smart Update Manager	81
HPE ROM-Based Setup Utility	81
Using RBSU	82
Auto-configuration process.....	82
Boot options.....	83
Configuring AMP modes.....	83
Re-entering the server serial number and product ID	83
Utilities and features.....	84
HPE Smart Storage Administrator.....	84
Option ROM Configuration for Arrays.....	84
ROMPaq utility.....	84
Automatic Server Recovery.....	85
USB support	85
Redundant ROM support.....	85
Keeping the system current.....	86
Drivers	86
Software and firmware.....	86
Version control.....	86
Operating systems and virtualization software support for ProLiant servers.....	87
HPE Technology Service Portfolio	87
Change control and proactive notification	87
Troubleshooting	88
Troubleshooting resources.....	88
System battery.....	89

Warranty and regulatory information	91
Warranty information	91
Regulatory information	91
Safety and regulatory compliance	91
Turkey RoHS material content declaration	91
Ukraine RoHS material content declaration	91
Electrostatic discharge	92
Preventing electrostatic discharge	92
Grounding methods to prevent electrostatic discharge	92
Specifications	93
Environmental specifications	93
Server specifications	93
Hot-plug power supply calculations	93
Support and other resources	94
Accessing Hewlett Packard Enterprise Support	94
Information to collect	94
Accessing updates	94
Websites	94
Customer Self Repair	95
Remote support	102
Acronyms and abbreviations	103
Documentation feedback	106
Index	107

Component identification

Front panel components

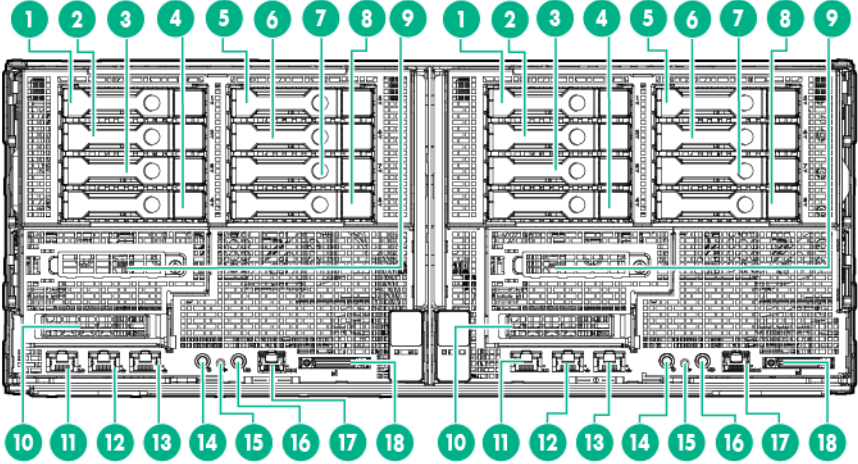

Item	Description
1	Hot-plug drive 1
2	Hot-plug drive 2
3	Hot-plug drive 3
4	Hot-plug drive 4
5	Hot-plug drive 5
6	Hot-plug drive 6
7	Hot-plug drive 7
8	Hot-plug drive 8
9	Option bay 2, FlexibleLOM
10	Option bay 1, PCI riser board
11	iLO 4 connector
12	NIC 2 connector
13	NIC 1 connector
14	Power On/Standby button and system power LED
15	Health LED
16	UID LED button
17	Serial connector
18	SUV connector

Front panel LEDs and buttons

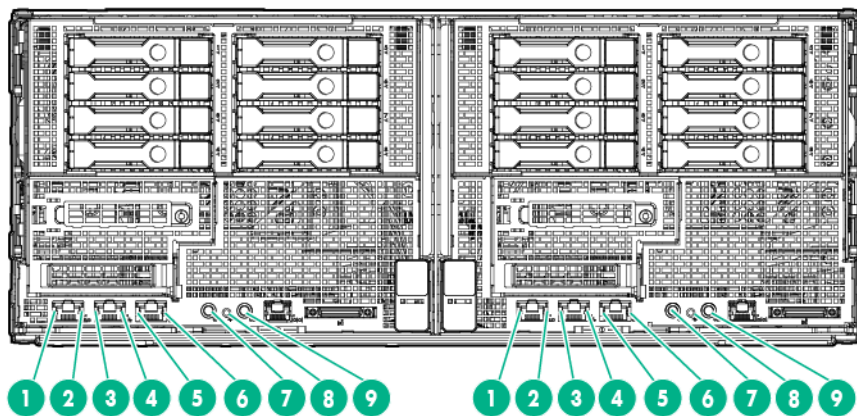

Item	Description	Status
1	iLO 4 speed LED	Green = LAN connection using a GbE link Amber = LAN connection using a 10 Mbps/100 Mbps link Off = No link exists
2	iLO 4 status LED	Solid green = Link to network Flashing green (1 Hz/cycle per sec) = Network active Off = No network activity
3	NIC 2 status LED	Solid green = Link to network Flashing green (1 Hz/cycle per sec) = Network active Off = No network activity
4	NIC 2 speed LED	Green = LAN connection using a GbE link Amber = LAN connection using a 10 Mbps/100 Mbps link Off = No link exists
5	NIC 1/iLO 4 status LED	Solid green = Link to network Flashing green (1 Hz/cycle per sec) = Network active Off = No network activity
6	NIC 1/iLO 4 speed LED	Green = LAN connection using a GbE link Amber = LAN connection using a 10 Mbps/100 Mbps link Off = No link exists
7	Power On/Standby button and system power LED	Solid green = System on Flashing green (1 Hz/cycle per sec) = Performing power on sequence Solid amber = System in standby Off = No power present**
8	Health LED	Solid green = Normal Flashing amber = System degraded Flashing red (1 Hz/cycle per sec) = System critical Fast-flashing red (4 Hz/cycles per sec) = Power fault*
9	UID button/LED	Solid blue = Activated Flashing blue (1 Hz/cycle per sec) = Remote management or firmware upgrade in progress Off = Deactivated

* To identify components in a degraded or critical state, see the iLO/BIOS logs and the server troubleshooting guide.

** Facility power is not present, power cord is not attached, no power supplies are installed, power supply failure has occurred, or the power button cable is disconnected.

Rear panel components

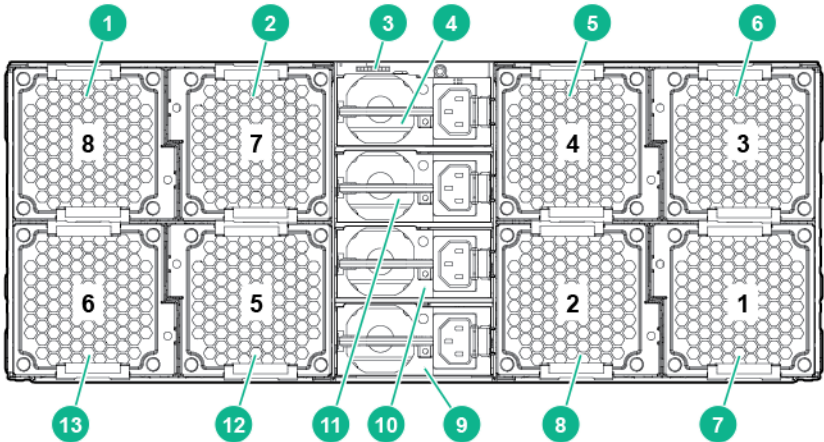

Item	Description
1	Fan 8
2	Fan 7
3	HPE APM interface
4	Power supply 4
5	Fan 4
6	Fan 3
7	Fan 1
8	Fan 2
9	Power supply 1
10	Power supply 2
11	Power supply 3
12	Fan 5
13	Fan 6

Rear panel LEDs and buttons

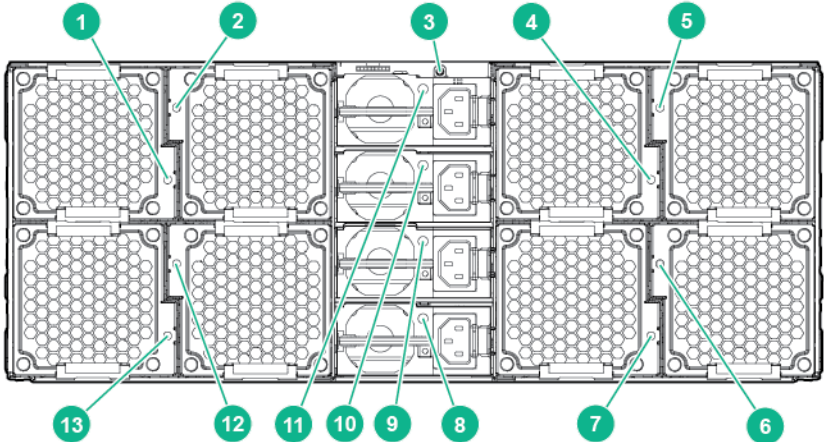

Item	Description	Status
1	Fan 8/16 power LED	Off—Normal Amber—Fan has failed.
2	Fan 7/15 power LED	Off—Normal Amber—Fan has failed.
3	UID LED button	Blue—Activated Flashing blue—System is being remotely managed. Off—Deactivated
4	Fan 4/12 power LED	Off—Normal Amber—Fan has failed.
5	Fan 3/11 power LED	Off—Normal Amber—Fan has failed.
6	Fan 1/9 power LED	Off—Normal Amber—Fan has failed.
7	Fan 2/10 power LED	Off—Normal Amber—Fan has failed.
8	Power supply 1 power LED	Green—Normal Off—No AC power
9	Power supply 2 power LED	Green—Normal Off—No AC power
10	Power supply 3 power LED	Green—Normal Off—No AC power
11	Power supply 4 power LED	Green—Normal Off—No AC power
12	Fan 5/13 power LED	Off—Normal Amber—Fan has failed.
13	Fan 6/14 power LED	Off—Normal Amber—Fan has failed.

System board components

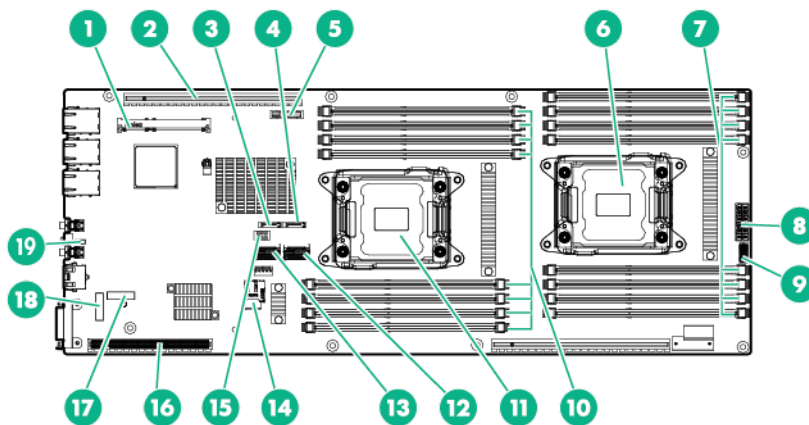

Item	Description
1	Cache module connector

Item	Description
2	PCIe x24 riser connector
3	SATA connector 2
4	SATA connector 1
5	System battery
6	Processor socket 2
7	Processor 2 DIMM slots
8	12-pin system board power connector
9	24-pin RPS connector
10	Processor 1 DIMM slots
11	Processor socket 1
12	Mini-SAS connector 2i
13	Mini-SAS connector 1i
14	microSD card slot
15	Hot-plug drive backplane sideband connector
16	FlexibleLOM x16 riser connector
17	System maintenance switch
18	TPM connector
19	NMI header

NOTE: This server supports PCIe Gen3 only in the FlexibleLOM slot. PCIe Gen2 is supported in all other slots.

DIMM slot locations

DIMM slots are numbered sequentially (1 through 8) for each processor. The supported AMP modes use the alpha assignments for population order, and the slot numbers designate the DIMM slot ID for spare replacement.

The arrow points to the front of the server.

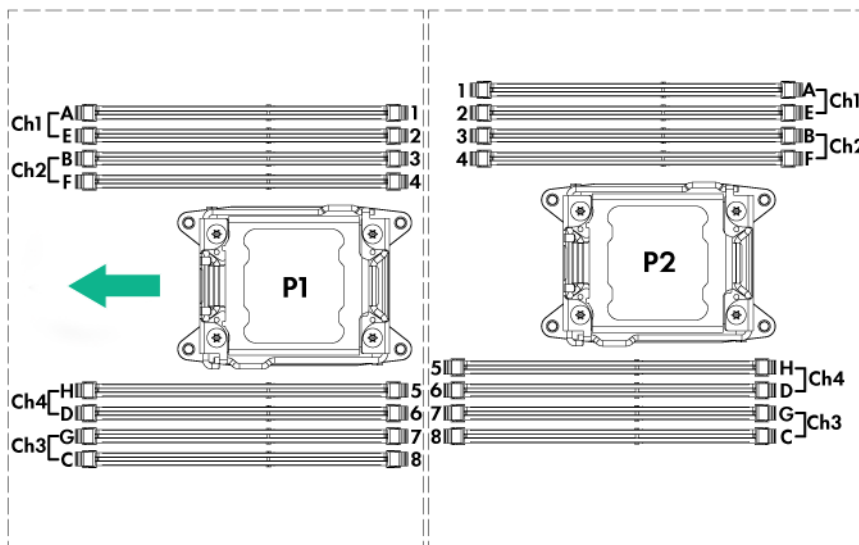

System maintenance switch

Position	Default	Function
S1	Off	Off = iLO 4 security is enabled. On = iLO 4 security is disabled.
S2	Off	Off = System configuration can be changed. On = System configuration is locked.
S3	Off	Reserved
S4	Off	Reserved
S5	Off	Off = Power-on password is enabled. On = Power-on password is disabled.
S6	Off	Off = No function On = ROM reads system configuration as invalid.
S7	—	Reserved
S8	—	Reserved
S9	—	Off = PCIe 64-bit BAR function (large BAR) is disabled. On = PCIe 64-bit BAR function (large BAR) is enabled.
S10	—	Reserved
S11	—	Reserved
S12	—	Reserved

To access the redundant ROM, set S1, S5, and S6 to on.

When the system maintenance switch position 6 is set to the On position, the system is prepared to erase all system configuration settings from both CMOS and NVRAM.



CAUTION: Clearing CMOS and/or NVRAM deletes configuration information. Be sure to properly configure the server or data loss could occur.

NMI functionality

An NMI crash dump creates a crash dump log before resetting a system which is not responding.

Crash dump log analysis is an essential part of diagnosing reliability problems, such as failures of operating systems, device drivers, and applications. Many crashes freeze a system, and the only available action for administrators is to restart the system. Resetting the system erases any information which could support problem analysis, but the NMI feature preserves that information by performing a memory dump before a system reset.

To force the system to invoke the NMI handler and generate a crash dump log, do one of the following:

- Use the iLO Virtual NMI feature.
- Short the NMI header ("[System board components](#)" on page 9).

For more information, see the Hewlett Packard Enterprise website (<http://www.hpe.com/support/NMI>).

Drive numbering

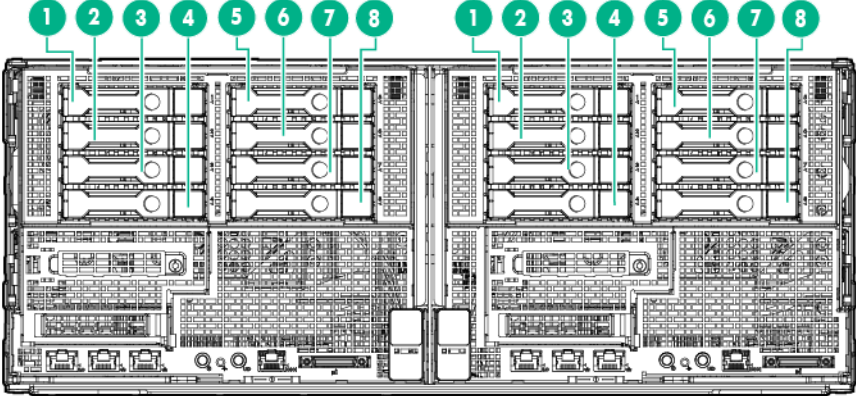

GPU numbering

- Left node

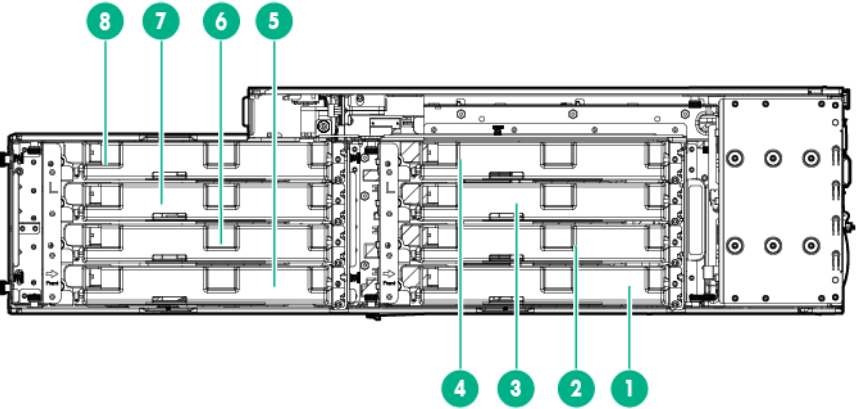

- Right node

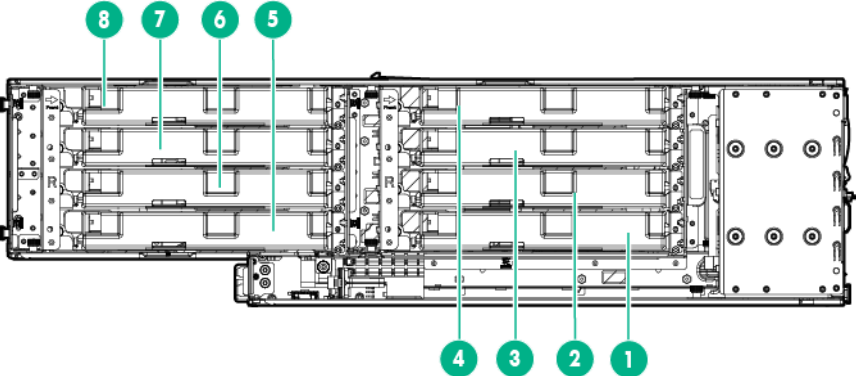

Hot-plug drive LED definitions

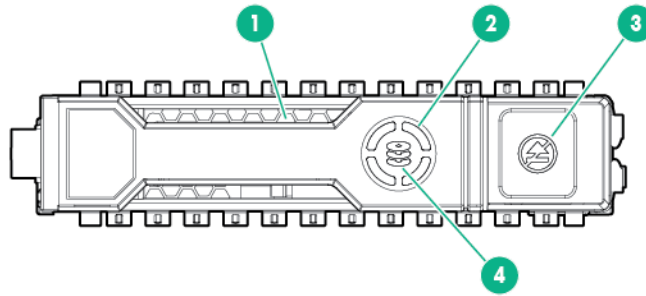

Item	LED	Status	Definition
1	Locate	Solid blue	The drive is being identified by a host application.
		Flashing blue	The drive carrier firmware is being updated or requires an update.
2	Activity ring	Rotating green	Drive activity
		Off	No drive activity
3	Do not remove	Solid white	Do not remove the drive. Removing the drive causes one or more of the logical drives to fail.
		Off	Removing the drive does not cause a logical drive to fail.
4	Drive status	Solid green	The drive is a member of one or more logical drives.
		Flashing green	The drive is rebuilding or performing a RAID migration, strip size migration, capacity expansion, or logical drive extension, or is erasing.
		Flashing amber/green	The drive is a member of one or more logical drives and predicts the drive will fail.
		Flashing amber	The drive is not configured and predicts the drive will fail.
		Solid amber	The drive has failed.
	Off	The drive is not configured by a RAID controller.	

Operations

Power up the server

To power up the server, press the Power On/Standby button.

Power down the server

Before powering down the server for any upgrade or maintenance procedures, perform a backup of critical server data and programs.



IMPORTANT: When the server is in standby mode, auxiliary power is still being provided to the system.

To power down the server, use one of the following methods:

- Press and release the Power On/Standby button.
This method initiates a controlled shutdown of applications and the OS before the server enters standby mode.
- Press and hold the Power On/Standby button for more than 4 seconds to force the server to enter standby mode.
This method forces the server to enter standby mode without properly exiting applications and the OS. If an application stops responding, you can use this method to force a shutdown.
- Use a virtual power button selection through iLO 4.
This method initiates a controlled remote shutdown of applications and the OS before the server enters standby mode.

Before proceeding, verify the server is in standby mode by observing that the system power LED is amber.

Remove the server from the chassis



WARNING: This server is very heavy. To reduce the risk of personal injury or damage to the equipment:

- Observe local occupational health and safety requirements and guidelines for manual material handling.
 - Get help to lift and stabilize the product during installation or removal, especially when the product is not fastened to the rails. Hewlett Packard Enterprise recommends that a minimum of two people are required for all rack server installations. A third person may be required to help align the server if the server is installed higher than chest level.
 - Use caution when installing the server in or removing the server from the rack; it is unstable when not fastened to the rails.
-

1. Power down the server (on page [14](#)).
2. Disconnect all peripheral cables and power cords.

3. Remove the server from the chassis.

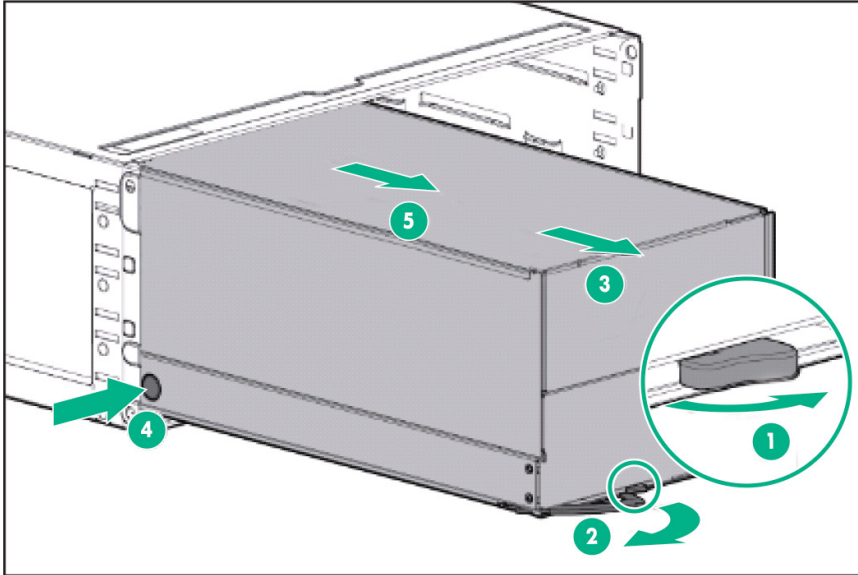

Remove the hot-plug SFF drive cage

To remove the component:

1. Power down the server (on page 14).
2. Disconnect all peripheral cables from the server.
3. Remove the server from the chassis (on page 14).
4. Remove the front shipping plate ("Remove the shipping brackets and shipping plates" on page 16).
5. Disconnect the cables from the drive cage backplane.
6. Remove the hot-plug SFF drive cage.

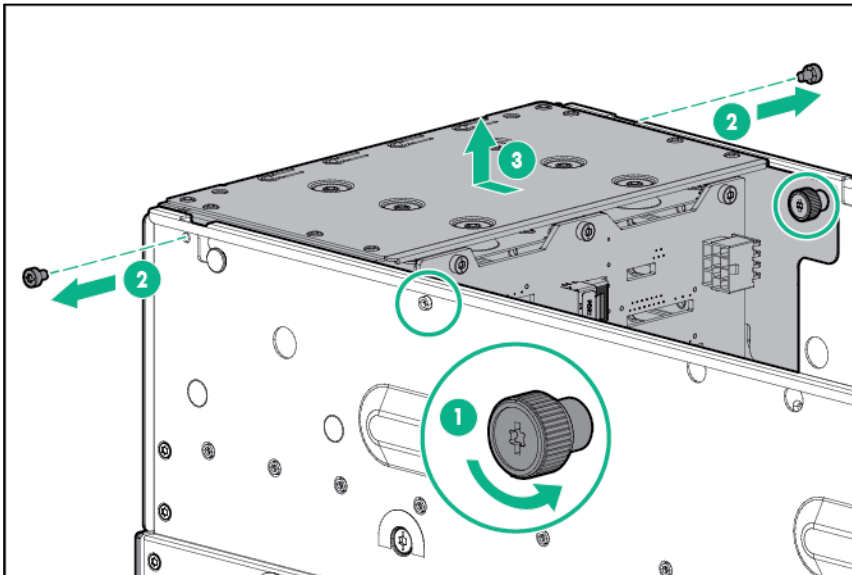

Install the hot-plug SFF drive cage

1. Install the hot-plug SFF drive cage.

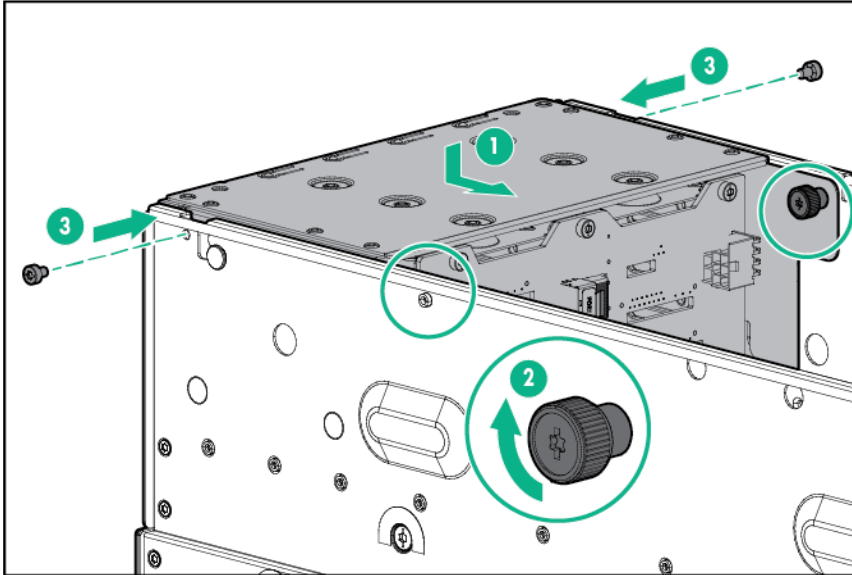

2. Connect the cables to the drive cage backplane.
3. Install the front shipping plate ("[Install the shipping brackets and shipping plates](#)" on page 18).
4. Install the server into the chassis ("[Installing the server into the chassis](#)" on page 30).
5. Connect the peripheral cables.
6. Power up the server (on page 14).

Remove the shipping brackets and shipping plates

To remove the component:

1. Power down the server (on page 14).
2. Disconnect all peripheral cables from the server.
3. Remove the server from the chassis (on page 14).

4. Remove the shipping brackets.

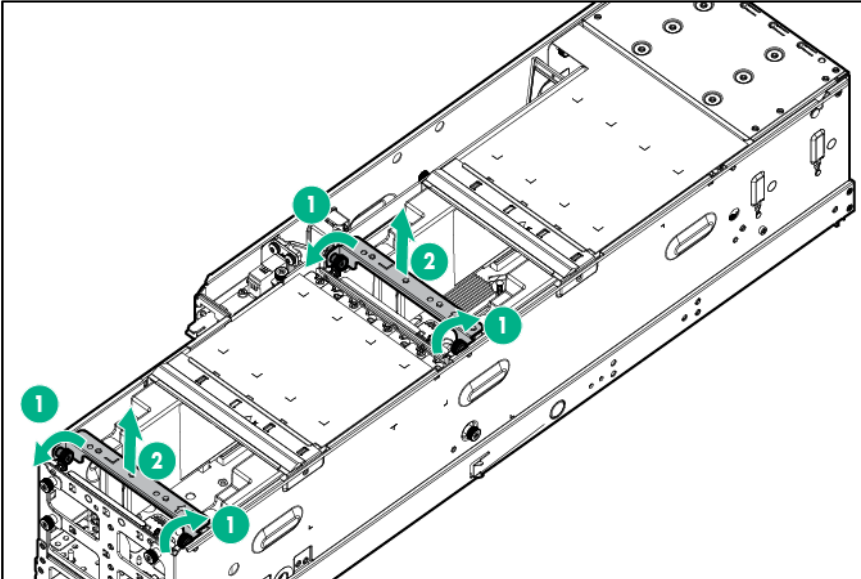

5. Remove the shipping plates.

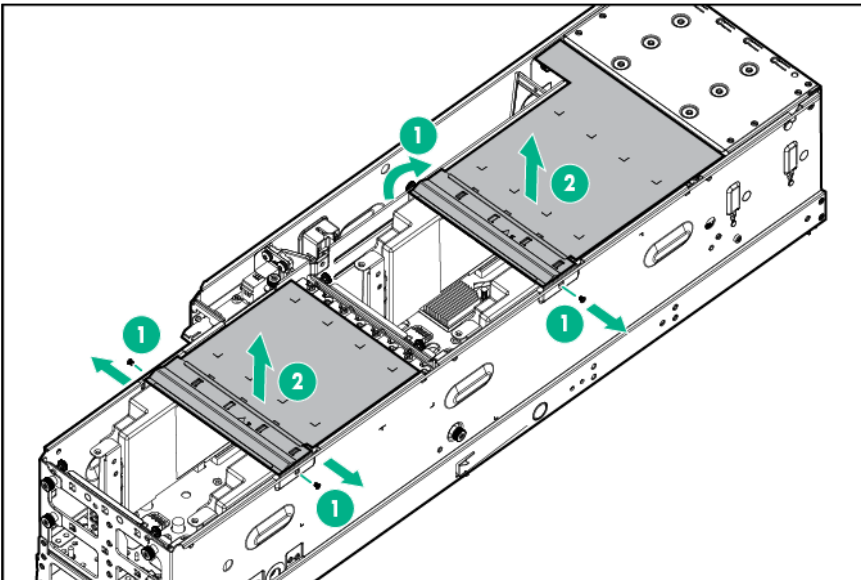

Install the shipping brackets and shipping plates

1. Install the shipping brackets.

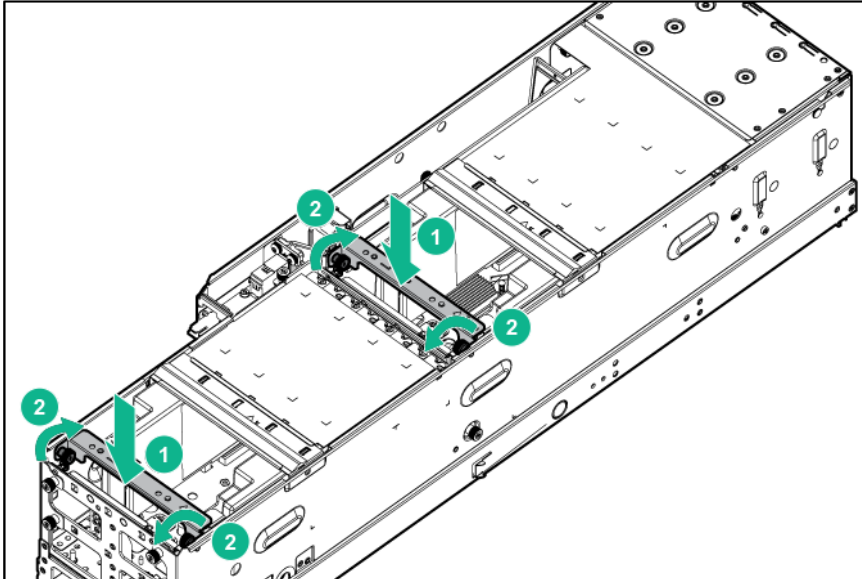

2. Install the shipping plates.
 - o Front shipping plates
 - NVIDIA Tesla M2075, M2090, and M2070Q

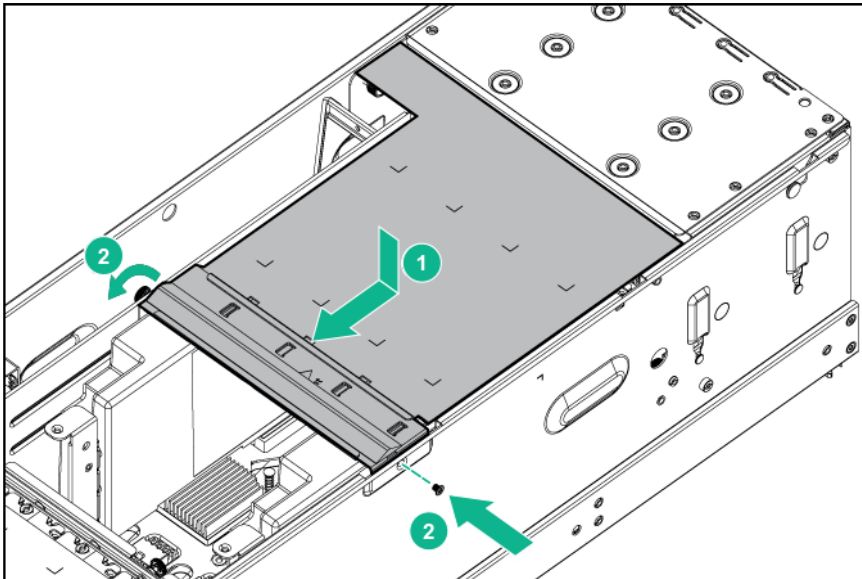

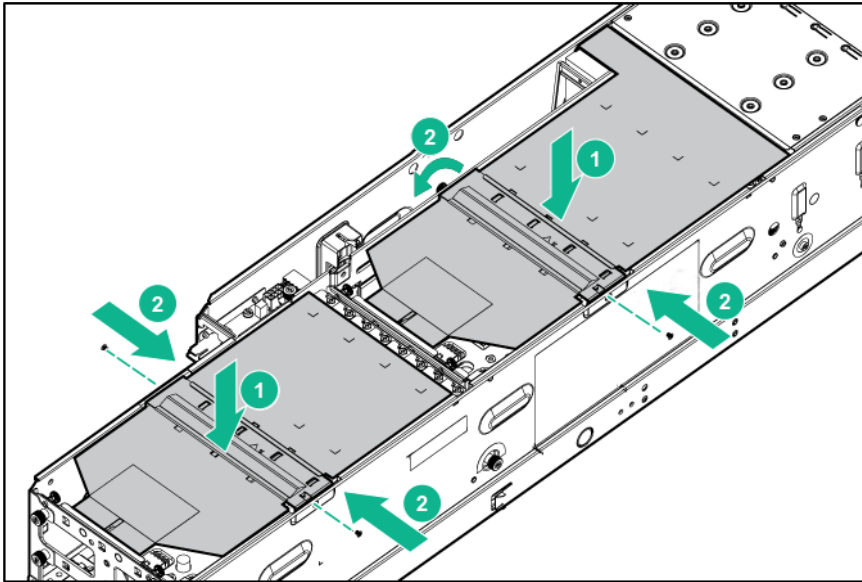

- o Rear shipping plates

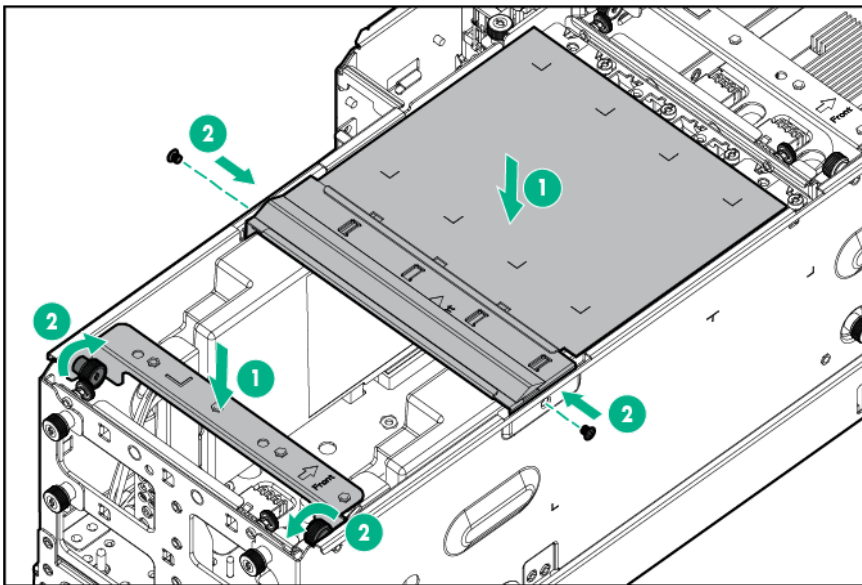

3. Install the server into the chassis ("[Installing the server into the chassis](#)" on page 30).
4. Connect the peripheral cables.
5. Power up the server (on page 14).

Remove the GPU cage

To remove the component:

1. Power down the server (on page 14).
2. Disconnect all peripheral cables from the server.
3. Remove the server from the chassis (on page 14).
4. Remove the shipping brackets and shipping plates (on page 16).
5. Remove the SFF hot-plug drive cage ("[Remove the hot-plug SFF drive cage](#)" on page 15).

6. Disconnect the GPU cage power cables.

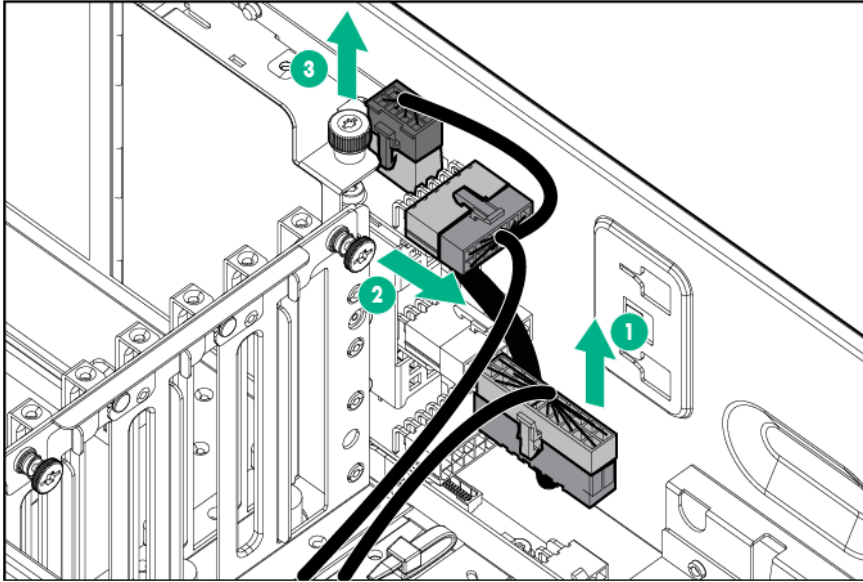

7. Loosen screws securing the GPU cage.

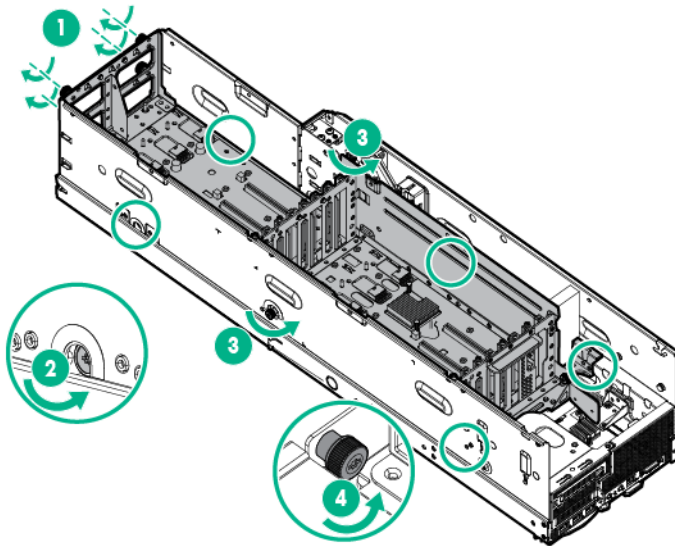

8. Remove the GPU cage:
 - a. Lift the front of the cage, and then lift the rear of the cage.

b. Remove the cage from the chassis.

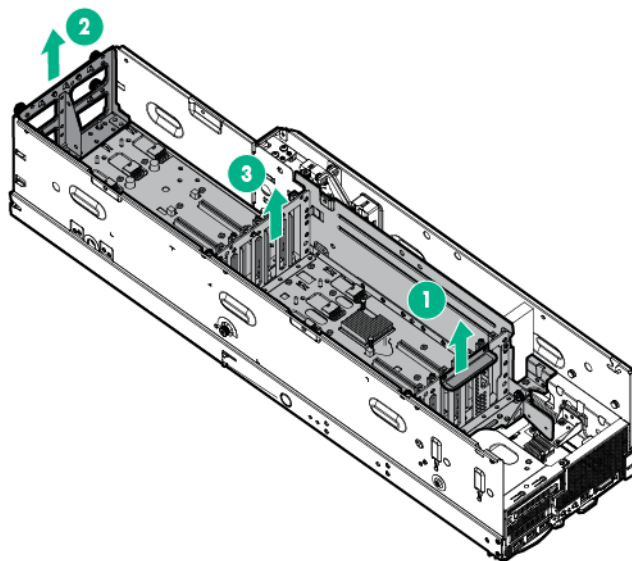

9. Disconnect the GPU cage power cable.

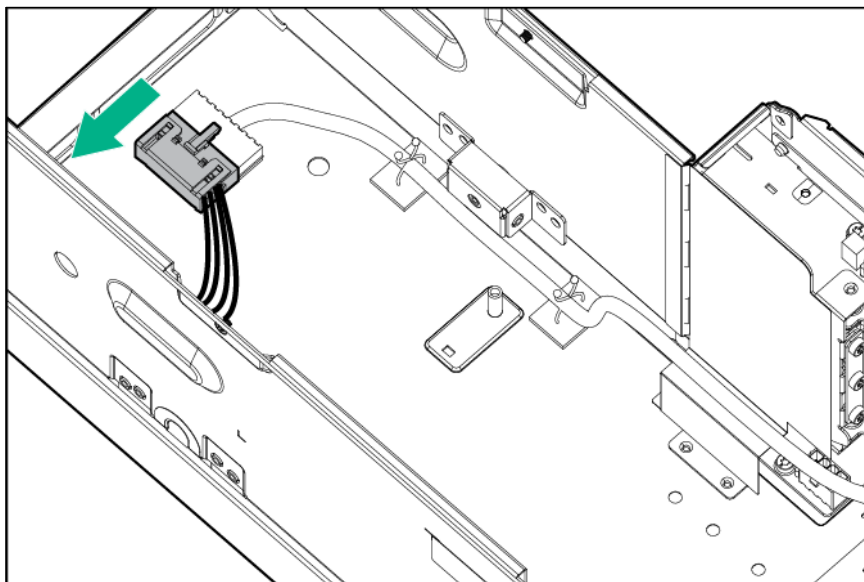

Install the GPU cage

1. Connect the power cable.

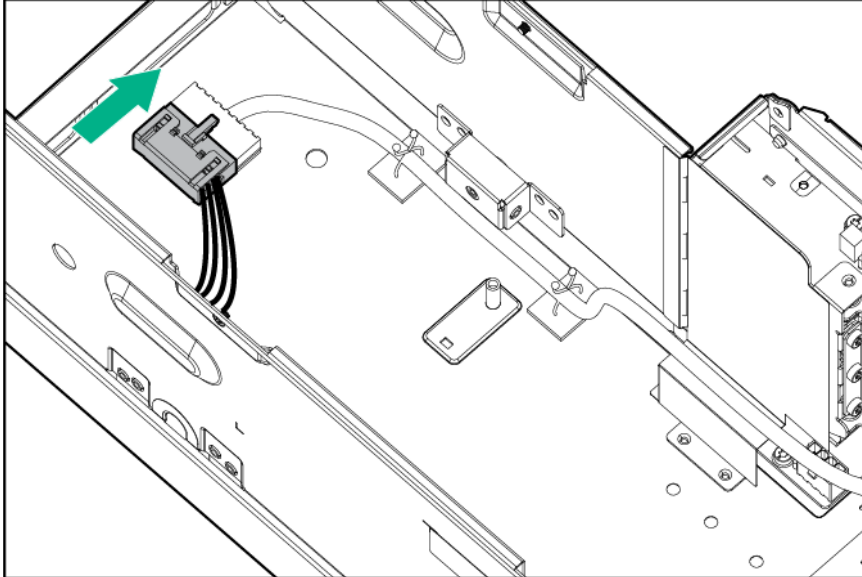

2. Install the GPU cage.

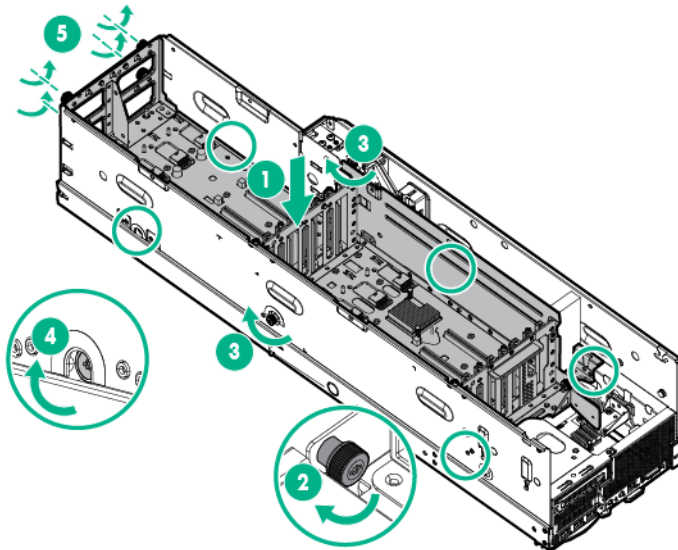

3. Connect the GPU cage power cables.
4. Install the SFF hot-plug drive cage ("[Install the hot-plug SFF drive cage](#)" on page 16).
5. Install the shipping brackets and shipping plates (on page 18).
6. Install the server into the chassis ("[Installing the server into the chassis](#)" on page 30).
7. Connect the peripheral cables.
8. Power up the server (on page 14).

Remove the processor air baffle

To remove the component:

1. Power down the server (on page 14).
2. Disconnect all peripheral cables from the server.
3. Remove the server from the chassis (on page 14).
4. Remove the shipping brackets and shipping plates (on page 16).
5. Remove the SFF hot-plug drive cage ("Remove the hot-plug SFF drive cage" on page 15).
6. Remove the GPU cage (on page 19).
7. Remove the processor air baffle.

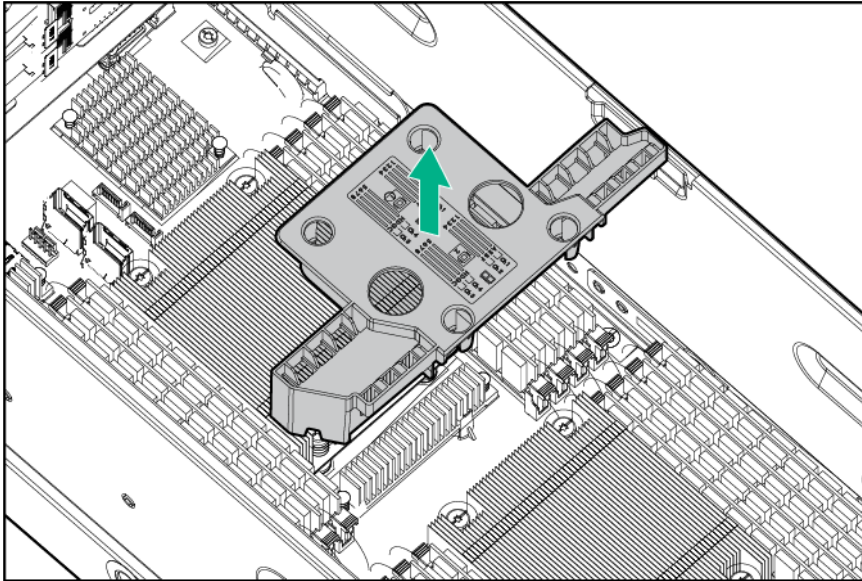

Install the processor air baffle

1. Install the processor air baffle.

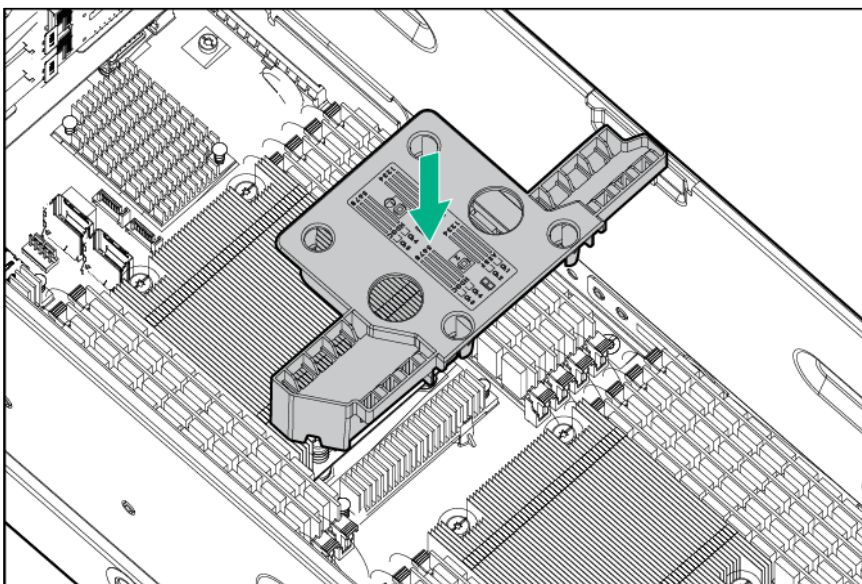

2. Install the GPU cage (on page 22)
3. Install the SFF hot-plug drive cage ("Install the hot-plug SFF drive cage" on page 16).
4. Install the shipping brackets and shipping plates (on page 18).
5. Install the server into the chassis ("Installing the server into the chassis" on page 30).
6. Connect the peripheral cables.
7. Power up the server (on page 14).

Remove the PCI/FlexibleLOM riser cage

1. Power down the server (on page 14).
2. Disconnect all peripheral cables from the server.
3. Remove the server from the chassis (on page 14).
4. Remove the shipping brackets and shipping plates (on page 16).
5. Remove the SFF hot-plug drive cage ("Remove the hot-plug SFF drive cage" on page 15).
6. Remove the GPU cage (on page 19).
7. If an expansion board is installed, disconnect all cables connected to it.
8. Remove and/or loosen the screws securing the PCI/FlexibleLOM riser cage.
 - Remove the screws on the left node
 - Loosen the thumbscrews on the right node
9. Lift the cage to unseat it from the system board:
 - o Left node

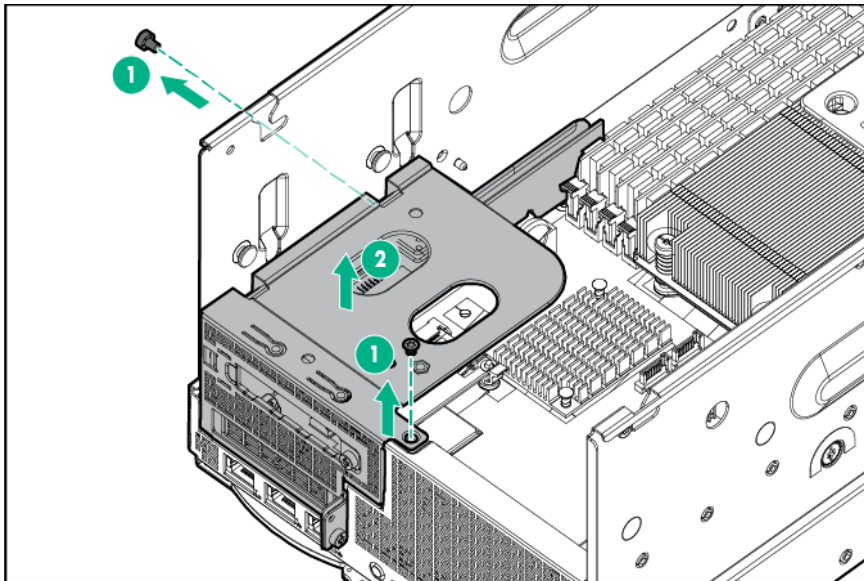

- o Right node

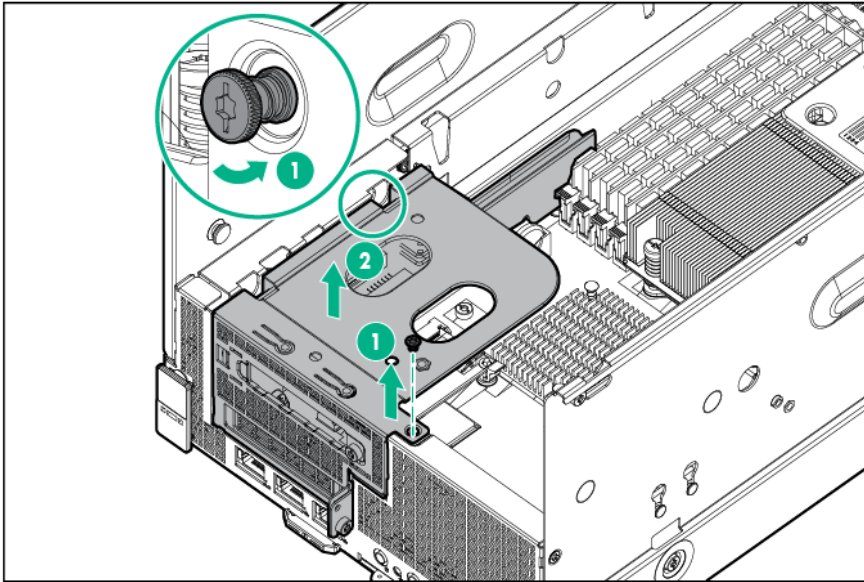

Install the PCI/FlexibleLOM riser cage

1. Install the PCI/FlexibleLOM riser cage.

- o Left node

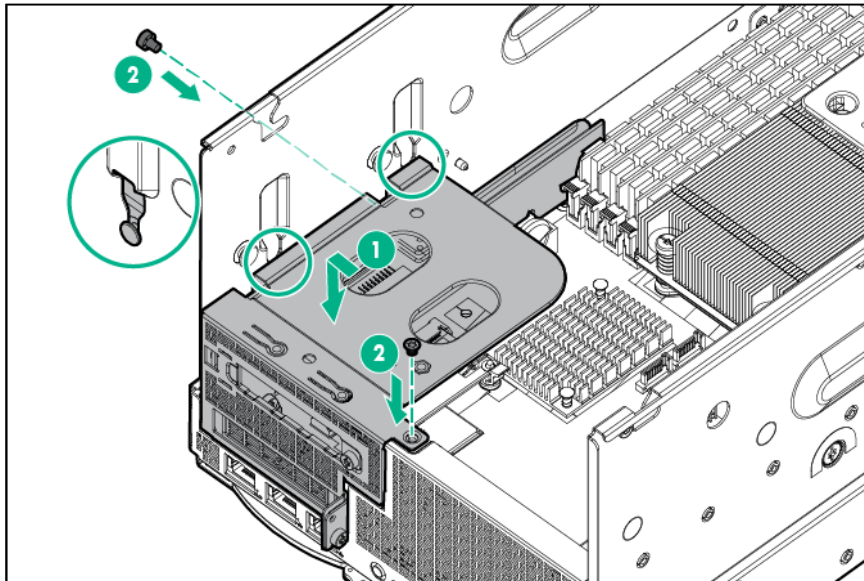

- o Right node

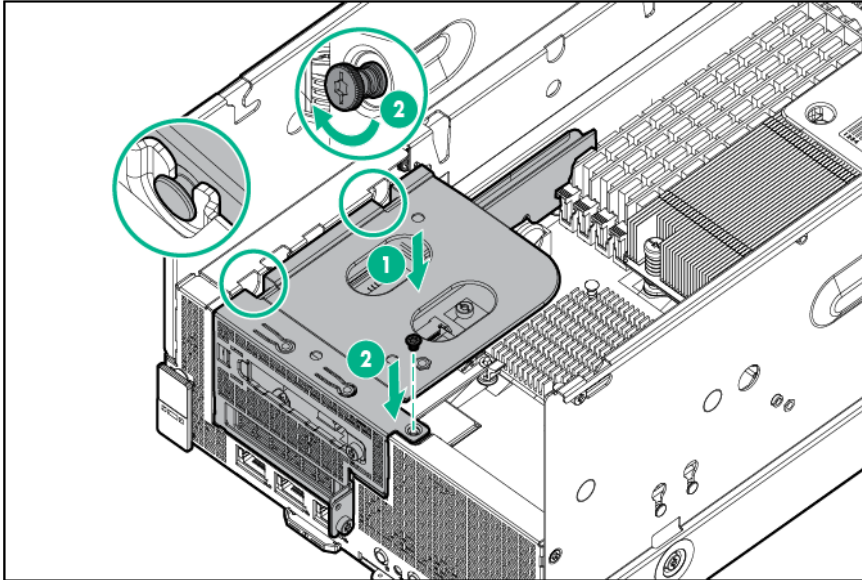

2. Install the GPU cage (on page 22).
3. Install the SFF hot-plug drive cage ("Install the hot-plug SFF drive cage" on page 16).
4. Install the shipping brackets and shipping plates (on page 18).
5. Install the server into the chassis ("Installing the server into the chassis" on page 30).
6. Connect the peripheral cables.
7. Power up the server (on page 14).

Setup

Optional services

Delivered by experienced, certified engineers, HP Care Pack services help you keep your servers up and running with support packages tailored specifically for HPE ProLiant systems. HP Care Packs let you integrate both hardware and software support into a single package. A number of service level options are available to meet your needs.

HP Care Pack Services offer upgraded service levels to expand your standard product warranty with easy-to-buy, easy-to-use support packages that help you make the most of your server investments. Some of the HP Care Pack services are:

- Hardware support
 - 6-Hour Call-to-Repair
 - 4-Hour 24x7 Same Day
 - 4-Hour Same Business Day
- Software support
 - Microsoft®
 - Linux
 - HPE ProLiant Essentials (HPE SIM and RDP)
 - VMware
- Integrated hardware and software support
 - Critical Service
 - Proactive 24
 - Support Plus
 - Support Plus 24
- Startup and implementation services for both hardware and software

For more information on HP Care Pack services, see the Hewlett Packard Enterprise website (<http://www.hpe.com/services/carepack>).

Optimum environment

When installing the server in a rack, select a location that meets the environmental standards described in this section.

Space and airflow requirements

To allow for servicing and adequate airflow, observe the following space and airflow requirements when deciding where to install a rack:

- Leave a minimum clearance of 63.5 cm (25 in) in front of the rack.
- Leave a minimum clearance of 76.2 cm (30 in) behind the rack.
- Leave a minimum clearance of 121.9 cm (48 in) from the back of the rack to the back of another rack or row of racks.

Hewlett Packard Enterprise servers draw in cool air through the front door and expel warm air through the rear door. Therefore, the front and rear rack doors must be adequately ventilated to allow ambient room air to enter the cabinet, and the rear door must be adequately ventilated to allow the warm air to escape from the cabinet.

 **CAUTION:** To prevent improper cooling and damage to the equipment, do not block the ventilation openings.

When vertical space in the rack is not filled by a server or rack component, the gaps between the components cause changes in airflow through the rack and across the servers. Cover all gaps with blanking panels to maintain proper airflow.

 **CAUTION:** Always use blanking panels to fill empty vertical spaces in the rack. This arrangement ensures proper airflow. Using a rack without blanking panels results in improper cooling that can lead to thermal damage.

The 9000 and 10000 Series Racks provide proper server cooling from flow-through perforations in the front and rear doors that provide 64 percent open area for ventilation.

 **CAUTION:** When using a Compaq branded 7000 series rack, install the high airflow rack door insert (PN 327281-B21 for 42U rack, PN 157847-B21 for 22U rack) to provide proper front-to-back airflow and cooling.

 **CAUTION:** If a third-party rack is used, observe the following additional requirements to ensure adequate airflow and to prevent damage to the equipment:

- Front and rear doors—If the 42U rack includes closing front and rear doors, you must allow 5,350 sq cm (830 sq in) of holes evenly distributed from top to bottom to permit adequate airflow (equivalent to the required 64 percent open area for ventilation).
- Side—The clearance between the installed rack component and the side panels of the rack must be a minimum of 7 cm (2.75 in).

Temperature requirements

To ensure continued safe and reliable equipment operation, install or position the system in a well-ventilated, climate-controlled environment.

The maximum recommended ambient operating temperature (TMRA) for most server products is 35°C (95°F). The temperature in the room where the rack is located must not exceed 35°C (95°F).

 **CAUTION:** To reduce the risk of damage to the equipment when installing third-party options:

- Do not permit optional equipment to impede airflow around the server or to increase the internal rack temperature beyond the maximum allowable limits.
- Do not exceed the manufacturer's TMRA.

Electrical grounding requirements

The server must be grounded properly for proper operation and safety. In the United States, you must install the equipment in accordance with NFPA 70, 1999 Edition (National Electric Code), Article 250, as well as any local and regional building codes. In Canada, you must install the equipment in accordance with Canadian Standards Association, CSA C22.1, Canadian Electrical Code. In all other countries, you must install the equipment in accordance with any regional or national electrical wiring codes, such as the International Electrotechnical Commission (IEC) Code 364, parts 1 through 7. Furthermore, you must be sure that all power distribution devices used in the installation, such as branch wiring and receptacles, are listed or certified grounding-type devices.

Because of the high ground-leakage currents associated with multiple servers connected to the same power source, Hewlett Packard Enterprise recommends the use of a PDU that is either permanently wired to the building's branch circuit or includes a nondetachable cord that is wired to an industrial-style plug.

NEMA locking-style plugs or those complying with IEC 60309 are considered suitable for this purpose. Using common power outlet strips for the server is not recommended.

Rack warnings

-
-  **WARNING:** To reduce the risk of personal injury or damage to the equipment, be sure that:
- The leveling jacks are extended to the floor.
 - The full weight of the rack rests on the leveling jacks.
 - The stabilizing feet are attached to the rack if it is a single-rack installation.
 - The racks are coupled together in multiple-rack installations.
 - Only one component is extended at a time. A rack may become unstable if more than one component is extended for any reason.
-

-  **WARNING:** To reduce the risk of personal injury or equipment damage when unloading a rack:
- At least two people are needed to safely unload the rack from the pallet. An empty 42U rack can weigh as much as 115 kg (253 lb), can stand more than 2.1 m (7 ft) tall, and might become unstable when being moved on its casters.
 - Never stand in front of the rack when it is rolling down the ramp from the pallet. Always handle the rack from both sides.
-

Contents of the server shipping carton

Unpack the server shipping carton and locate the materials and documentation necessary for installing the server. All the rack mounting hardware necessary for installing the server into the rack is included with the rack or the server.

The contents of the server shipping carton include:

- Server
- Power cord
- Printed setup documentation and software products
- Rack mounting hardware kit and documentation

In addition to these supplied items, you might need:

- T-10/T-15 Torx screwdriver
- Hardware options
- Operating system or application software

Installing the chassis

The chassis can be installed either in a rack or rack-free environment. For rack installations, install the rack rails, and then install the chassis and other components.

For more information, see the chassis setup and installation guide, the installation instructions for the Quick Deploy Rail System that ship with the rack hardware kit, and applicable installation instructions.

Installing the chassis components

⚠ WARNING: To avoid risk of personal injury or damage to the equipment, do not stack anything on top of rail-mounted equipment or use it as a work surface when extended from the rack.

⚠ CAUTION: Always plan the rack installation so that the heaviest item is on the bottom of the rack. Install the heaviest item first, and continue to populate the rack from the bottom to the top.

Before installing the chassis components, review chassis bay numbering for each component. For slot numbering information, see the quick setup instructions.

Based on the total number ordered and the planned configuration, install the following components:

- Node
- Node blank
- Power supplies
- Power supply blanks
- System fans

Installing the server into the chassis

⚠ WARNING: This server is very heavy. To reduce the risk of personal injury or damage to the equipment:

- Observe local occupational health and safety requirements and guidelines for manual material handling.
 - Get help to lift and stabilize the product during installation or removal, especially when the product is not fastened to the rails. Hewlett Packard Enterprise recommends that a minimum of two people are required for all rack server installations. A third person may be required to help align the server if the server is installed higher than chest level.
 - Use caution when installing the server in or removing the server from the rack; it is unstable when not fastened to the rails.
-

1. Insert the system tray into the chassis.
2. Rotate the tray handle to lock.

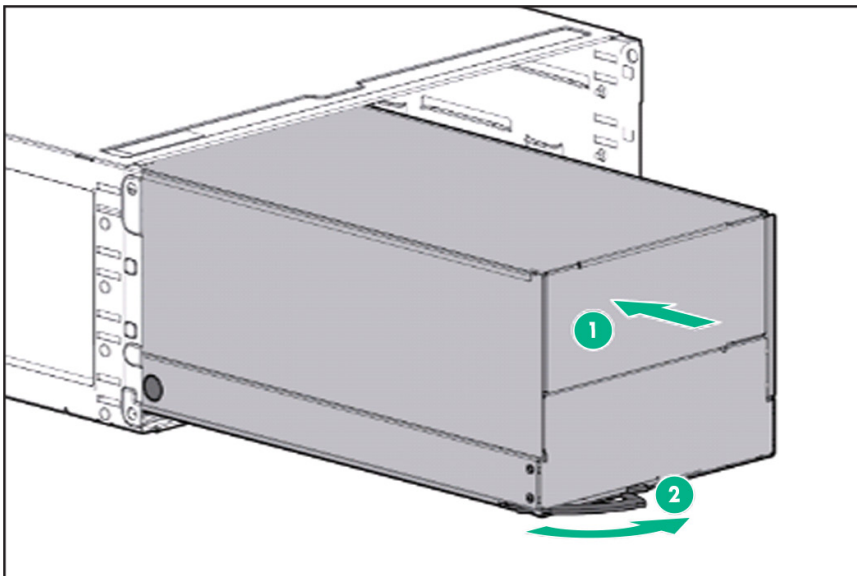

3. Connect peripheral devices to the server.



WARNING: To reduce the risk of electric shock, fire, or damage to the equipment, do not plug telephone or telecommunications connectors into RJ-45 connectors.

4. Connect the power cords to the power supplies.
5. Connect the power cord to the AC power source.



WARNING: To reduce the risk of electric shock or damage to the equipment:

- Do not disable the power cord grounding plug. The grounding plug is an important safety feature.
 - Plug the power cord into a grounded (earthed) electrical outlet that is easily accessible at all times.
 - Unplug the power cord from the power supply to disconnect power to the equipment.
 - Do not route the power cord where it can be walked on or pinched by items placed against it. Pay particular attention to the plug, electrical outlet, and the point where the cord extends from the server.
-

Powering up the chassis

Connect the AC or DC power cables, depending on the power configuration.

When the circuit breakers are powered, the chassis and HPE ProLiant s6500 Chassis have power. By default, each installed component also powers up. Examine the Advanced Power Manager for any errors which may prevent installed components from powering up.

Configuring the chassis

For further information on setting up and configuring your system, see the quick setup instructions for the chassis and the chassis setup and installation guide.

Powering on and selecting boot options

1. Connect the Ethernet cable between the network connector on the server and a network jack.
2. Press the Power On/Standby button.
3. During the initial boot:
 - a. To modify the server configuration ROM default settings, press **F9** when prompted from the start up sequence to enter the RBSU. By default, RBSU runs in the English language.
 - b. If you do not need to modify the server configuration and are ready to install the system software, press **F10** to access Intelligent Provisioning.

NOTE: If an HPE Smart Array controller has been added or is embedded in the system, the controller defaults to a RAID configuration based on the size and number of drives installed. For more information on modifying the controller default settings, see the documentation in the Smart Storage Information Library (<http://www.hpe.com/info/smartstorage/docs>).

For more information on automatic configuration, see the RBSU user guide on the Hewlett Packard Enterprise website (<http://www.hpe.com/support/rbsu>).

Installing the system software

To access and configure Intelligent Provisioning on a single node:

1. Access Intelligent Provisioning by rebooting the server and pressing **F10**.

2. The first time you log into Intelligent Provisioning, follow the steps to set preferences and activate Intelligent Provisioning.
3. From the Home screen, click **Perform Maintenance**, and then click **Firmware Update**.
4. Ensure the latest drivers are available for installation. Select **Intelligent Provisioning Software** from the list of firmware, and click **Update**. If the check box is not selected, the latest drivers are already installed.

Registering the server

To experience quicker service and more efficient support, register the product at the Hewlett Packard Enterprise Product Registration website (<http://www.hpe.com/info/register>).

Hardware options installation

Introduction

If more than one option is being installed, read the installation instructions for all the hardware options and identify similar steps to streamline the installation process.

WARNING: To reduce the risk of personal injury from hot surfaces, allow the drives and the internal system components to cool before touching them.

CAUTION: To prevent damage to electrical components, properly ground the server before beginning any installation procedure. Improper grounding can cause electrostatic discharge.

Connecting the SUV cable

CAUTION: Before disconnecting the SUV cable from the connector, always squeeze the release buttons on the sides of the connector. Failure to do so can result in damage to the equipment.

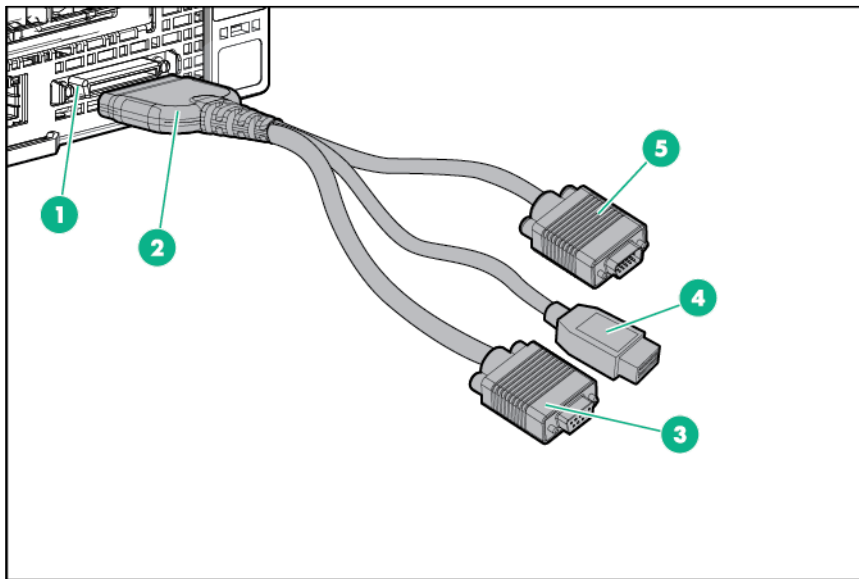

Item	Connector	Description
1	SUV port	SUV port on the server front panel
2	SUV connector	For connecting to the SUV connector on the server front panel
3	Video	For connecting a video monitor
4	USB	For connecting up to two USB devices
5	Serial	For trained personnel to connect a null modem serial cable and perform advanced diagnostic procedures

Drive options

The embedded storage controller supports SATA drive installation. For SAS drive installation, install the storage controller card ("[Controller options](#)" on page 35) and Mini-SAS cable option ("[Mini-SAS Y-cable option](#)" on page 41) kits. The storage controller card option supports both SATA and SAS drives.

 **WARNING:** To reduce the risk of injury from electric shock, do not remove more than one drive carrier at a time.

Drive installation guidelines

When adding drives to the server, observe the following general guidelines:

- The system automatically sets all device numbers.
- Populate drive bays, based on the drive numbering sequence. Start from the drive bay with the lowest device number ("[Drive numbering](#)" on page 12).
- When drives are grouped together into the same drive array, they must be of the same capacity to provide the greatest storage space efficiency.

Installing a hot-plug drive

1. Remove the drive blank.

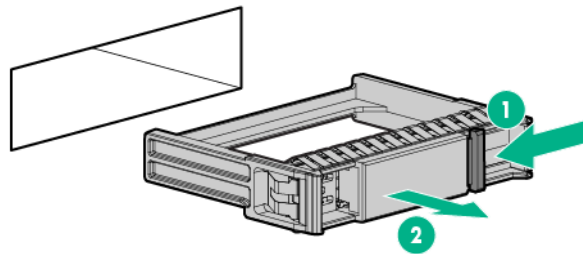

2. Prepare the drive.

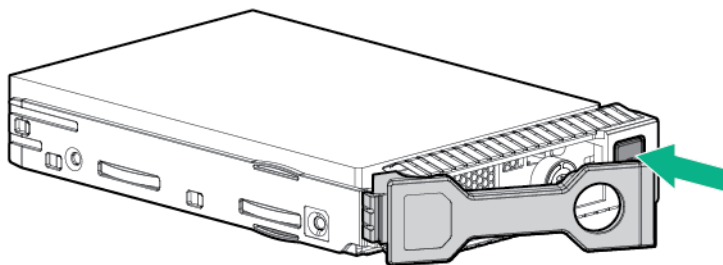

3. Install the drive.

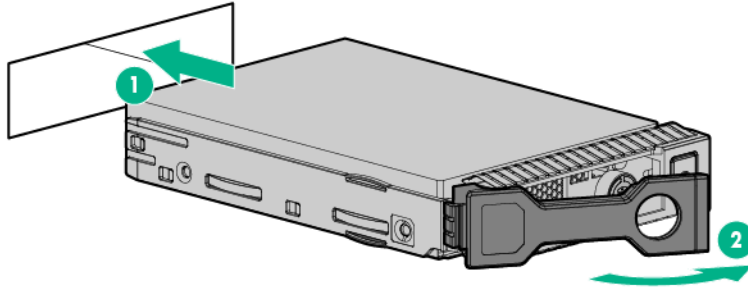

4. Determine the status of the drive from the drive LED definitions ("Hot-plug drive LED definitions" on page 13).

Controller options

The server ships with HPE Smart Array H220i Controller. For more information about the storage controller and its features, select the relevant controller user documentation on the Hewlett Packard Enterprise website (http://www.hpe.com/support/SAC_UG_ProLiantServers_en).

To configure arrays, see the user guide for Smart Array Controllers on the Hewlett Packard Enterprise website (http://www.hpe.com/support/CASAC_RG_en).

Upgrade options exist for the integrated array controller. For a list of supported options, see the QuickSpecs on the Hewlett Packard Enterprise website (<http://www.hpe.com/info/qs>).

The server supports FBWC. FBWC consists of a cache module and a capacitor pack. The DDR cache module buffers and stores data being written by the controller. When the system is powered on, the capacitor pack charges fully in about 5 minutes. In the event of a system power failure, a fully charged capacitor pack provides power for up to 80 seconds. During that interval, the controller transfers the cached data from DDR memory to flash memory, where the data remains indefinitely or until a controller retrieves the data.



CAUTION: The cache module connector does not use the industry-standard DDR3 mini-DIMMs. Do not use the controller with cache modules designed for other controller models, because the controller can malfunction and you can lose data. Also, do not transfer this cache module to an unsupported controller model, because you can lose data.



CAUTION: To prevent a server malfunction or damage to the equipment, do not add or remove the battery pack while an array capacity expansion, RAID level migration, or stripe size migration is in progress.



CAUTION: After the server is powered down, wait 15 seconds and then check the amber LED before unplugging the cable from the cache module. If the amber LED blinks after 15 seconds, do not remove the cable from the cache module. The cache module is backing up data, and data is lost if the cable is detached.



IMPORTANT: The battery pack might have a low charge when installed. In this case, a POST error message is displayed when the server is powered up, indicating that the battery pack is temporarily disabled. No action is necessary on your part. The internal circuitry automatically recharges the batteries and enables the battery pack. This process might take up to four hours. During this time, the cache module functions properly, but without the performance advantage of the battery pack.

NOTE: The data protection and the time limit also apply if a power outage occurs. When power is restored to the system, an initialization process writes the preserved data to the hard drives.

Installing the FBWC module and capacitor pack

△ **CAUTION:** In systems that use external data storage, be sure that the server is the first unit to be powered down and the last to be powered back up. Taking this precaution ensures that the system does not erroneously mark the drives as failed when the server is powered up.

1. Power down the server (on page 14).
2. Disconnect all peripheral cables from the server.
3. Remove the server from the chassis (on page 14).
4. Remove the shipping brackets and shipping plates (on page 16).
5. Remove the SFF hot-plug drive cage ("[Remove the hot-plug SFF drive cage](#)" on page 15).
6. Remove the GPU cage (on page 19).
7. If using a storage controller, remove the PCI riser cage ("[Remove the PCI/FlexibleLOM riser cage](#)" on page 24).
8. Connect the capacitor pack cable to the cache module.

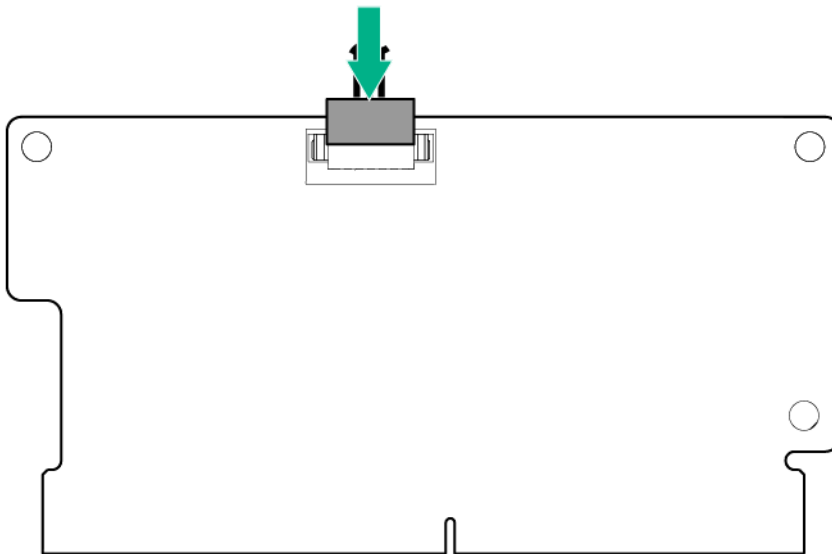

9. Do one of the following:

- Install the cache module in the SAS cache module connector on the system board. For connector locations, see "System board components (on page 9)."

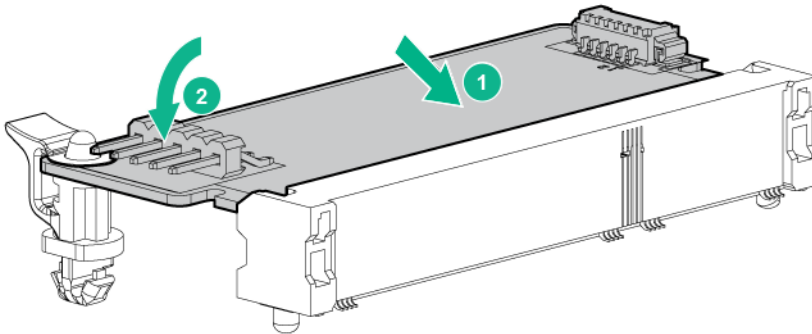

- Install the cache module into the storage controller.

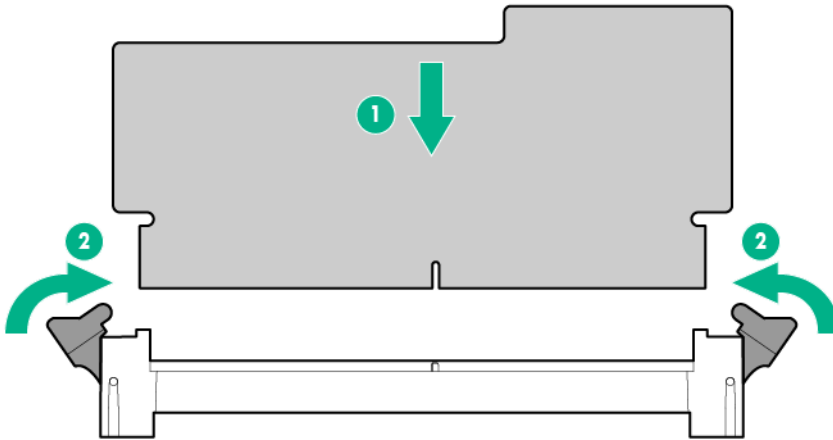

10. If using a storage controller, install the controller card into the PCI riser cage.
11. Install the PCI riser cage ("[Install the PCI/FlexibleLOM riser cage](#)" on page 25).
12. Route the FBWC capacitor pack cable as indicated below:

- o Left node

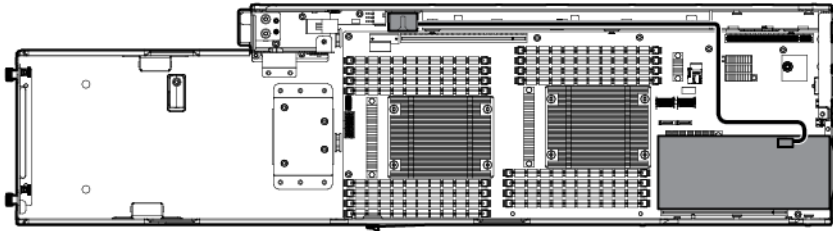

- o Right node

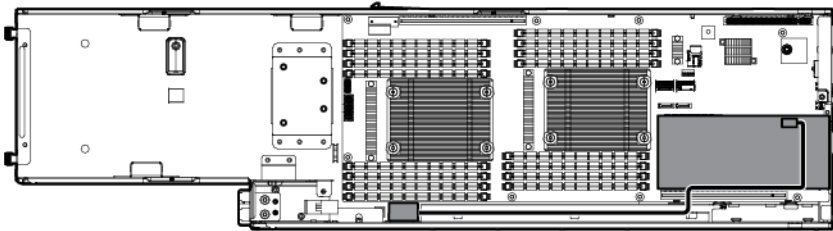

13. Install the FBWC capacitor pack into the holder mounted in the server tray.

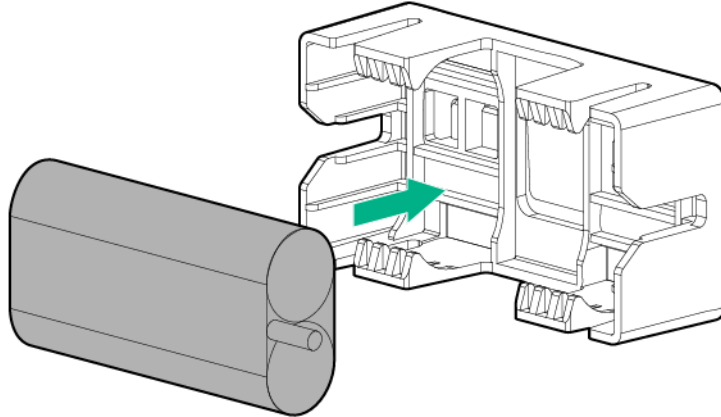

14. Install the GPU cage (on page 22).
15. Install the SFF hot-plug drive cage ("Install the hot-plug SFF drive cage" on page 16).
16. Install the shipping brackets and shipping plates (on page 18).
17. Install all components removed from the server.
18. Install the server into the chassis ("Installing the server into the chassis" on page 30).
19. Connect the peripheral cables.
20. Power up the server (on page 14).

Expansion board or FlexibleLOM adapter option

To install either component:

1. Power down the server (on page 14).
2. Disconnect all peripheral cables from the server.
3. Remove the server from the chassis (on page 14).
4. Remove the shipping brackets and shipping plates (on page 16).
5. Remove the SFF hot-plug drive cage ("Remove the hot-plug SFF drive cage" on page 15).
6. Remove the GPU cage (on page 19).
7. Remove the PCI/FlexibleLOM riser cage (on page 24).

8. Remove the expansion slot cover from the PCI/FlexibleLOM riser cage.

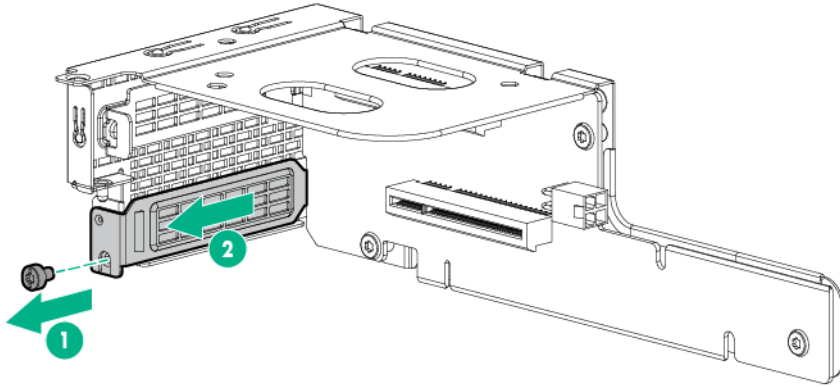

IMPORTANT: If the expansion board ships with an extender bracket, remove it from the expansion board before inserting the board into the expansion slot of the PCI riser board assembly.

9. Install the expansion board or FlexibleLOM into the slot until it seats firmly.
 - o FlexibleLOM

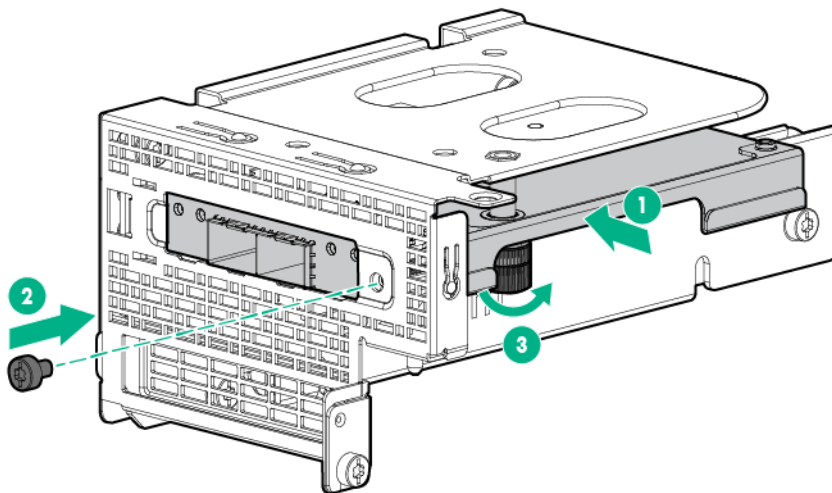

- o Expansion board

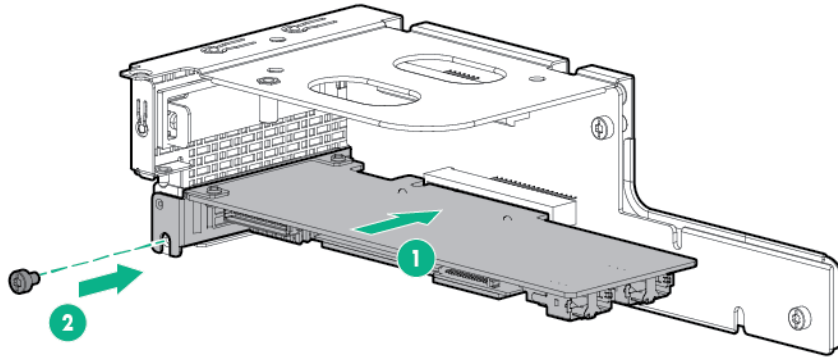

10. Connect all internal or external cabling to the installed board.
11. Install the GPU cage (on page 22).
12. Install the SFF hot-plug drive cage ("Install the hot-plug SFF drive cage" on page 16).
13. Install the shipping brackets ("Install the shipping brackets and shipping plates" on page 18).
14. Install the server into the chassis ("Installing the server into the chassis" on page 30).
15. Connect the peripheral cables.
16. Power up the server (on page 14).

Mini-SAS Y-cable option

1. Power down the server (on page 14).
2. Disconnect all peripheral cables from the server.
3. Remove the server from the chassis (on page 14).
4. Remove the shipping brackets and shipping plates (on page 16).
5. Remove the SFF hot-plug drive cage

- a. Disconnect all cables from the drive cage backplane.

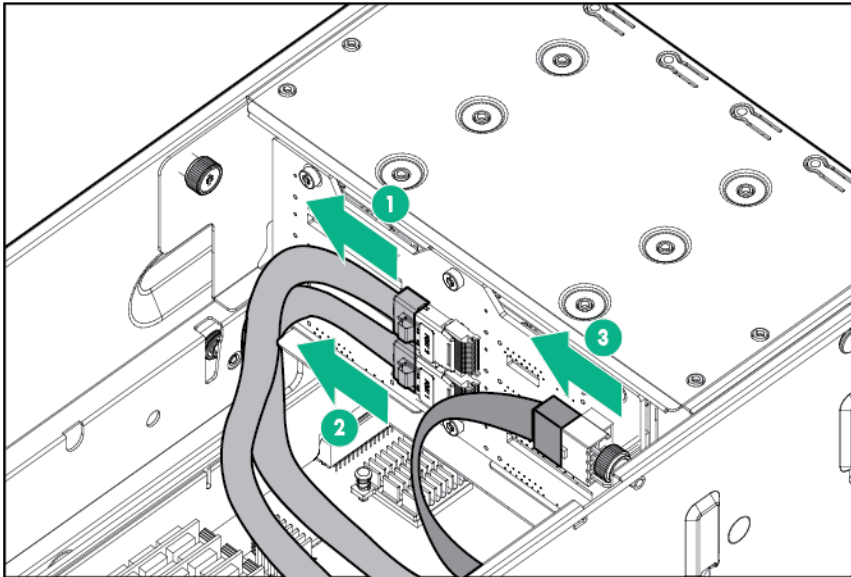

- b. Disconnect the existing Mini-SAS cables from the system board.
c. Remove the hot-plug drive cage.

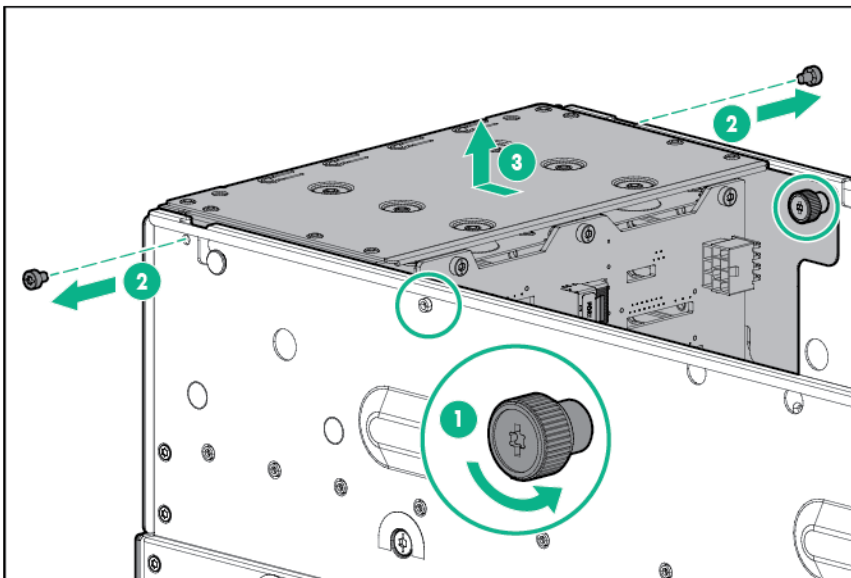

6. Remove the GPU cage (on page 19).
7. Remove the PCI/FlexibleLOM riser cage (on page 24).

8. Connect the common end of the Mini-SAS Y-cable to the controller option.

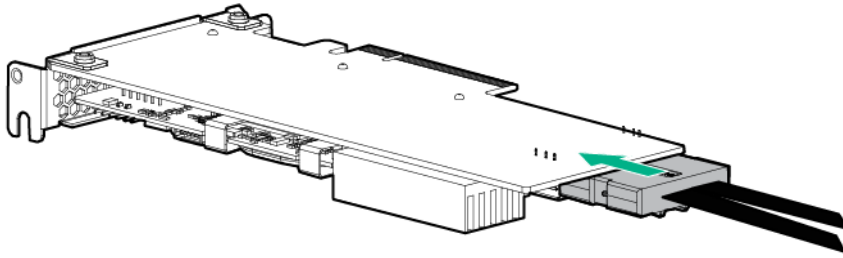

9. Install the storage controller ("[Controller options](#)" on page 35).
10. Install the PCI riser cage ("[Install the PCI/FlexibleLOM riser cage](#)" on page 25).
11. Install the SFF hot-plug drive cage ("[Install the hot-plug SFF drive cage](#)" on page 16).
12. Connect the Mini-SAS Y-cable:
 - a. Connect the split ends of the Mini-SAS Y-cable to the drive backplane. Ensure that the labels on the cable match the backplane connectors:
 - HDD SAS 1 cable = Port 1
 - HDD SAS 2 cable = Port 2
 - b. Connect the power cable to the backplane.

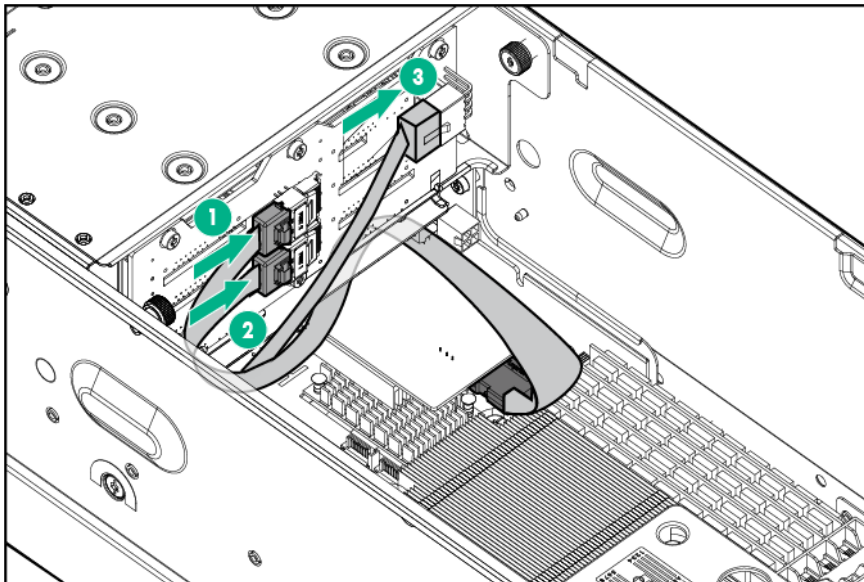

- c. To prevent interference with the DIMMs and heatsink, bend the Mini-SAS Y-cable upwards, and then tuck it underneath the drive cage.

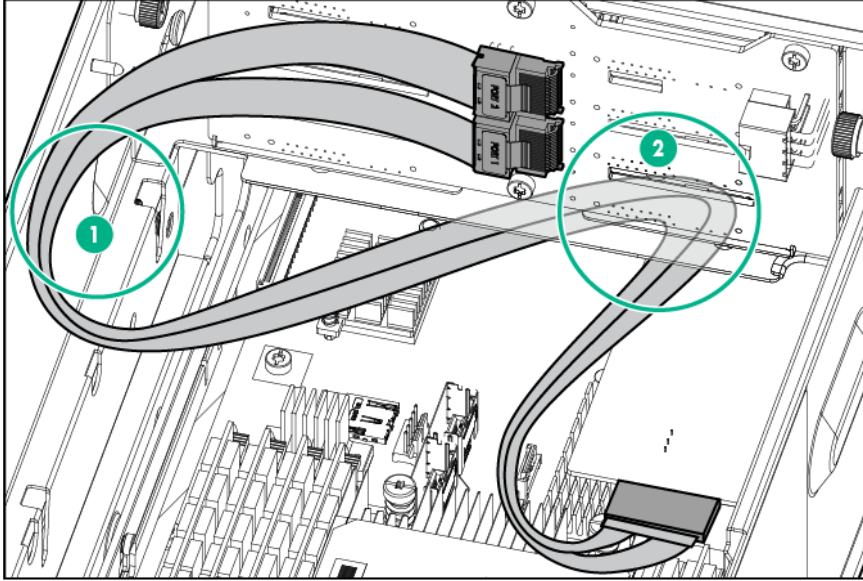

13. Install the GPU cage (on page 22)

14. Install the shipping brackets and shipping plates (on page 18).

GPU/coprocessor enablement options

Large BAR setting for coprocessor installation

Coprocessor model	Number of coprocessor supported	Switch position 9 setting
Intel Xeon Phi 5110P	1 - 8	On = Enabled
Intel Xeon Phi 7120P	1 - 6	On = Enabled

The system board embedded HPE Dynamic Smart Array B320i Controller does not support large BAR function. When the large BAR function is enabled, drive connection to the system board SATA/Mini-SAS connectors is not supported. Connect installed drives to a storage controller board.

The minimum system requirement for the system board embedded Dynamic Smart Array B320i Controller to support large Bar function is version P75 2013. 09 .08.

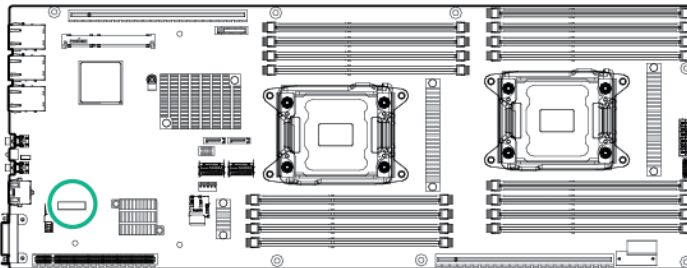

Before installing a coprocessor option, set the system maintenance switch position 9 to the setting indicated in the table below:

Coprocessor model	Number of coprocessor supported	Switch position 9 setting
Intel Xeon Phi 5110P	1 - 8	On = Enabled
Intel Xeon Phi 7120P	1 - 6	On = Enabled

The system board embedded HPE Dynamic Smart Array B320i Controller does not support large BAR function. When the large BAR function is enabled, drive connection to the system board SATA/Mini-SAS connectors is not supported. Connect installed drives to a storage controller board. The minimum system requirement for the system board embedded Dynamic Smart Array B320i Controller to support large Bar function is version P75 2013. 09 .08.

Coprocessor model	Number of coprocessor supported	Switch position 9 setting
NVIDIA Tesla M2075 and M2090	1 - 8	Off = Disabled
NVIDIA Tesla M2070Q, K20, K20X, K40, K10, and GRID K2	1 - 8	On = Enabled
Intel Xeon Phi 5110P	1 - 8	On = Enabled
Intel Xeon Phi 7120P	1 - 6	On = Enabled

The system board embedded Dynamic Smart Array B320i Controller does not support large BAR function. When the large BAR function is enabled, drive connection to the system board SATA/Mini-SAS connectors is not supported. Connect installed drives to a storage controller board. The minimum system requirement for the system board embedded Dynamic Smart Array B320i Controller to support large Bar function is version P75 2013. 09 .08.

GPU population rules

Observe the following population rules when installing a coprocessor or GPU in the server:

- Left node

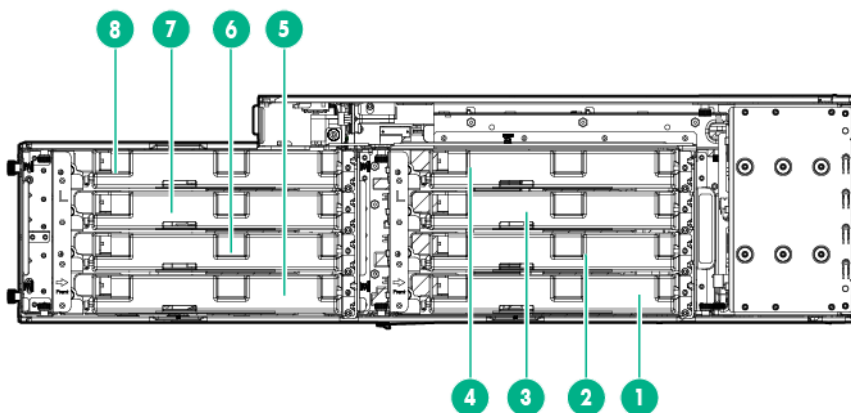

- Right node

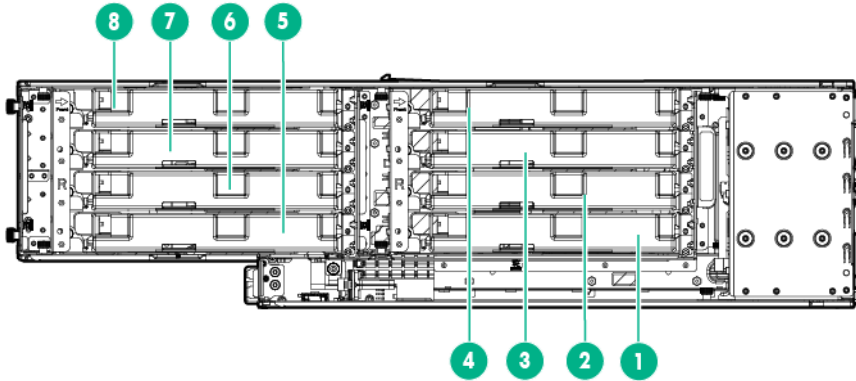

CAUTION: For proper cooling, be sure that all slots in the GPU cage are occupied by a coprocessor or a GPU blank.

Number of coprocessor	Front GPU cage bay 1 (PCIe x16 slot 1 = GPU 1)	Front GPU cage bay 2 (PCIe x16 slot 2 = GPU 2)	Front GPU cage bay 3 (PCIe x16 slot 3 = GPU 3)	Front GPU cage bay 4 (PCIe x16 slot 4 = GPU 4)	Rear GPU cage bay 1 (PCIe x16 slot 5 = GPU 5)	Rear GPU cage bay 2 (PCIe x16 slot 6 = GPU 6)	Rear GPU cage bay 3 (PCIe x16 slot 7 = GPU 7)	Rear GPU cage bay 4 (PCIe x16 slot 8 = GPU 8)
1	Yes	GPU blank	GPU blank	GPU blank	GPU blank	GPU blank	GPU blank	GPU blank
2	Yes	GPU blank	GPU blank	Yes	GPU blank	GPU blank	GPU blank	GPU blank
3	Yes	GPU blank	GPU blank	Yes	GPU blank	GPU blank	Yes	GPU blank
4	Yes	GPU blank	GPU blank	Yes	GPU blank	Yes	Yes	GPU blank
5	Yes	Yes	GPU blank	Yes	GPU blank	Yes	Yes	GPU blank
6	Yes	Yes	Yes	GPU blank	GPU blank	Yes	Yes	Yes
7	Yes	Yes	Yes	GPU blank	Yes	Yes	Yes	Yes
8	Yes	Yes	Yes	Yes	Yes	Yes	Yes	Yes

Coprocessor enablement option

1. Power down the server (on page 14).
2. Disconnect all peripheral cables from the server.
3. Remove the server from the chassis (on page 14).
4. Remove the shipping brackets and shipping plates (on page 16).

5. Remove the PCI retaining brackets.

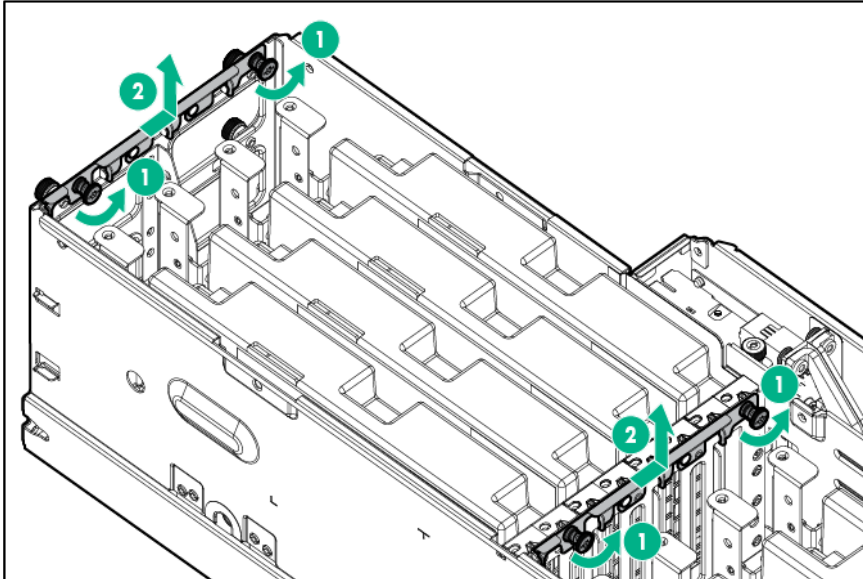

6. If installed, remove the GPU blank:
 - a. Remove the screw on the left end of the blank. Retain this screw for coprocessor installation.
 - b. Loosen the captive screw on the right end of the blank.
 - c. Remove the GPU blank.

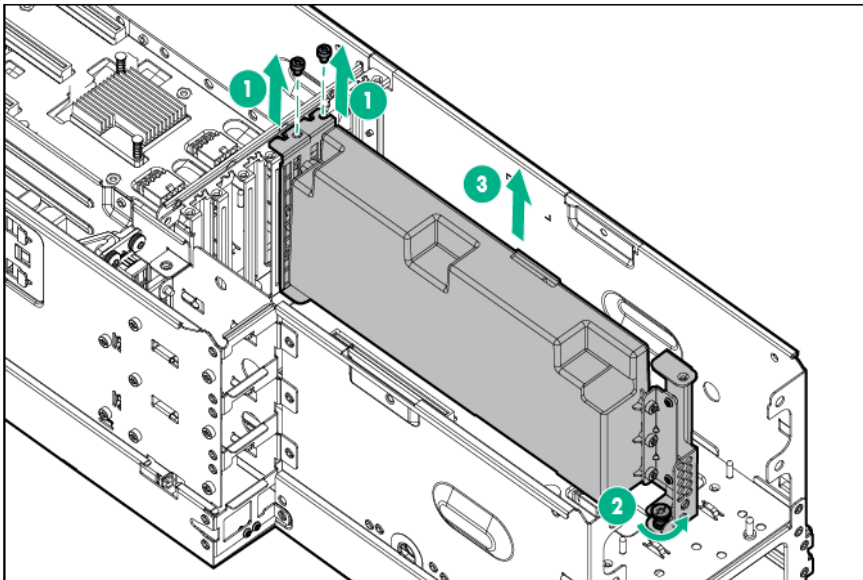

7. To determine power specification, see the documentation that came with the coprocessor. Use this information to decide which power cable is required to complete the coprocessor installation.

8. Attach the support bracket to the coprocessor. To secure the bracket, use the screws that came with the coprocessor option.

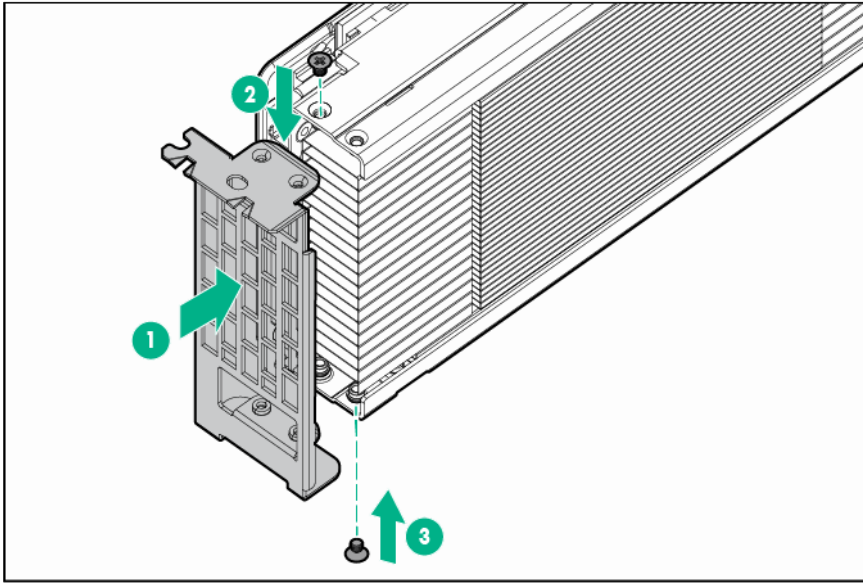

9. If installing a 225 W coprocessor, connect the preinstalled power cable to the coprocessor:
 - a. Install the coprocessor.
 - b. Connect the preinstalled power cable to the 8-pin power connector of the coprocessor:
 - Front GPU cage

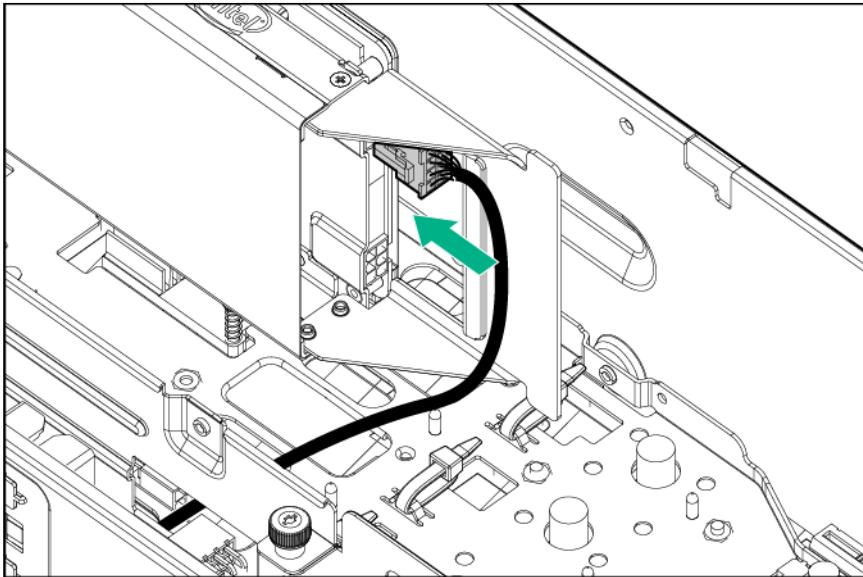

— Rear GPU cage

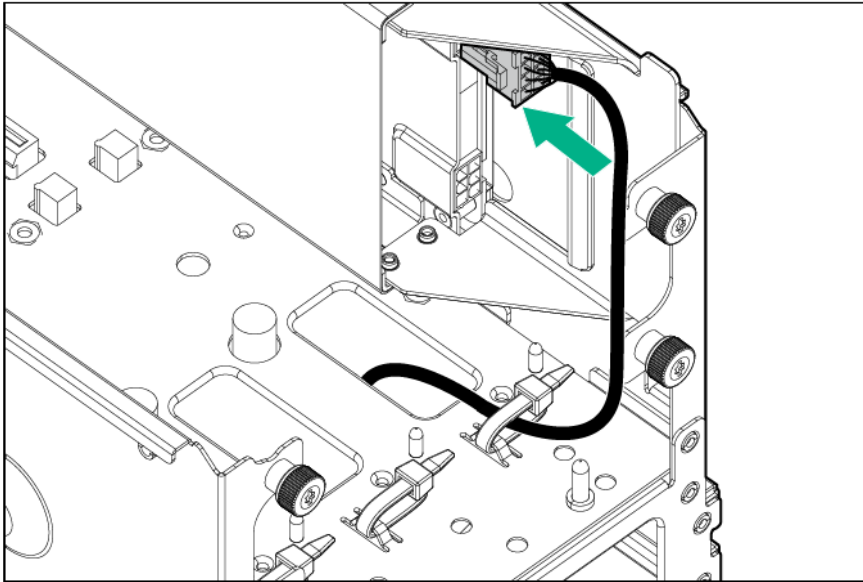

10. If installing a 300 W coprocessor, connect the power Y-cable included in this kit:
 - a. Cut the cable tie and disconnect the preinstalled coprocessor power cable from the GPU cage board.
 - b. Secure the power Y-cable in the cable clip, and then connect the common end of the cable to the GPU cage power connector.

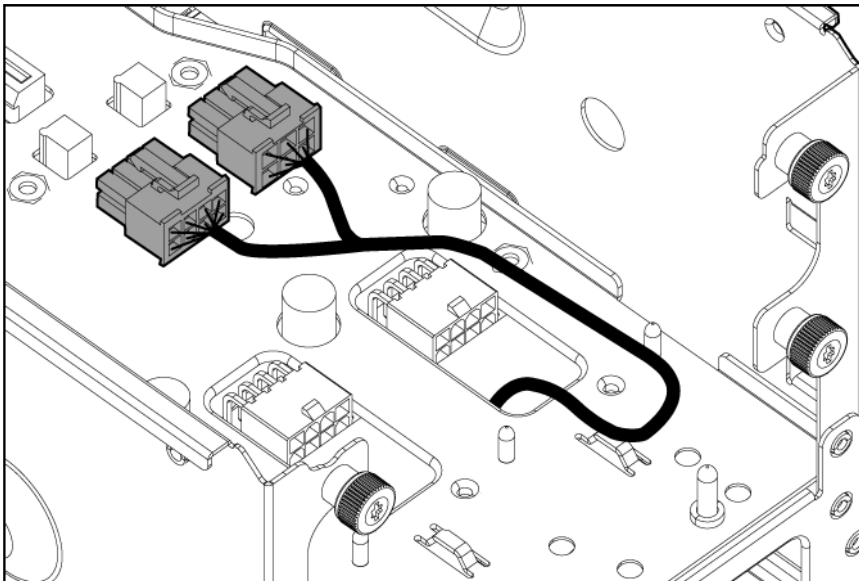

- c. Install the coprocessor.
 - d. Secure the coprocessor with the screw retained from removing the GPU blank (step 4a).

- e. Connect the split ends of the power Y-cable to the coprocessor by connecting the 6-pin end to the lower connector and connecting the 8-pin end to the upper connector.

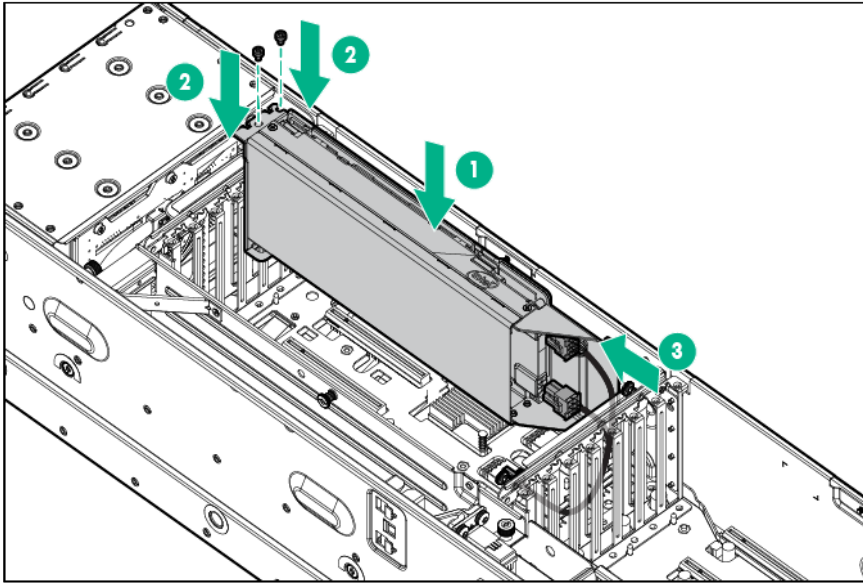

11. Install the PCI retaining bracket.
12. Install the shipping plate ("Install the shipping brackets and shipping plates" on page 18).
The shipping bracket is no longer required after the coprocessor installation. Retain it for future use.
13. Install the server into the chassis ("Installing the server into the chassis" on page 30).
14. Connect the peripheral cables.
15. Power up the server (on page 14).

GPU enablement option

1. rPower down the server (on page 14).
2. Disconnect all peripheral cables from the server.
3. Remove the server from the chassis (on page 14).
4. Remove the shipping brackets and shipping plates (on page 16).

5. If installed, remove the GPU blank.

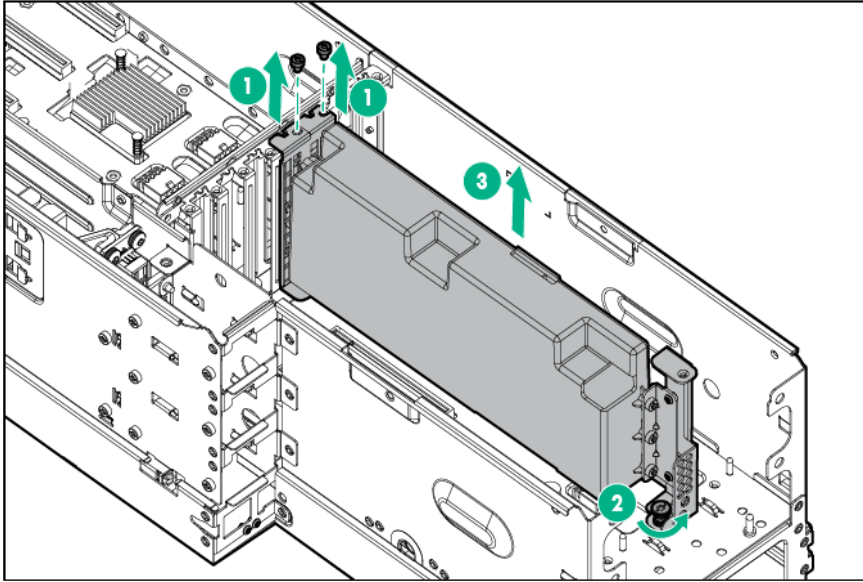

6. Install the front I/O bracket.

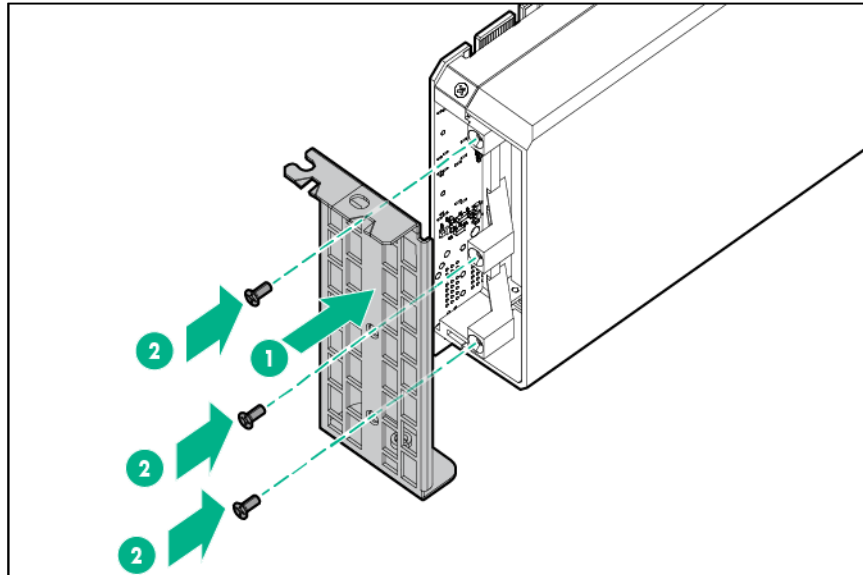

7. Install the GPU into the server.

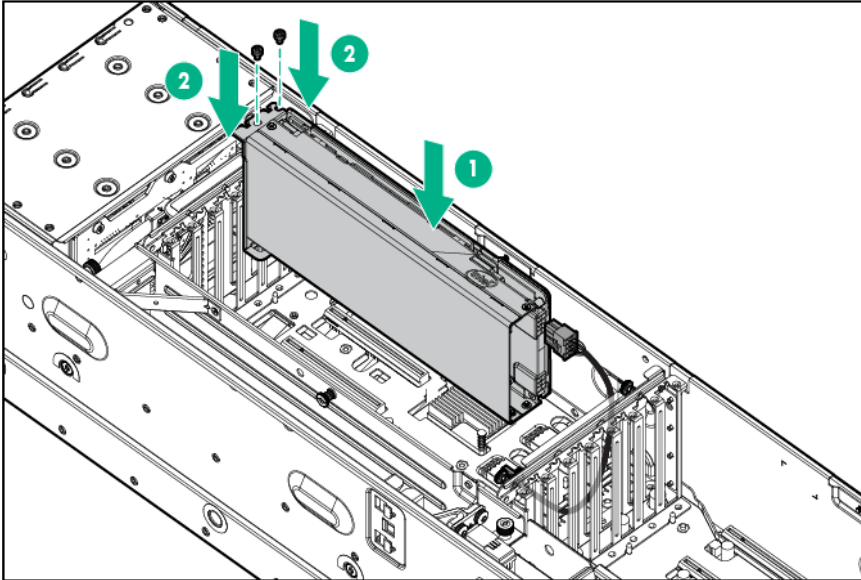

8. Connect the preinstalled GPU power cable and the GPU power capping cable to the GPU.

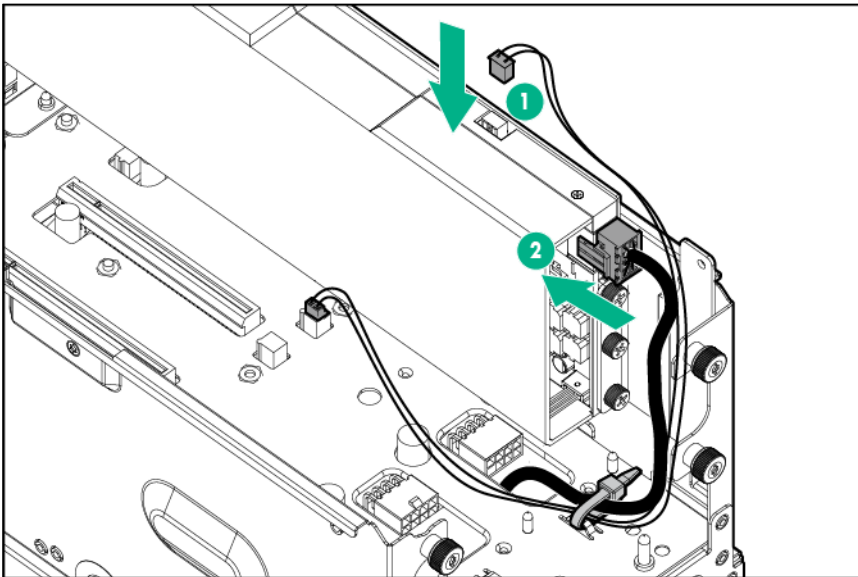

9. Install the PCI retaining bracket.

10. Install the extended shipping plate.

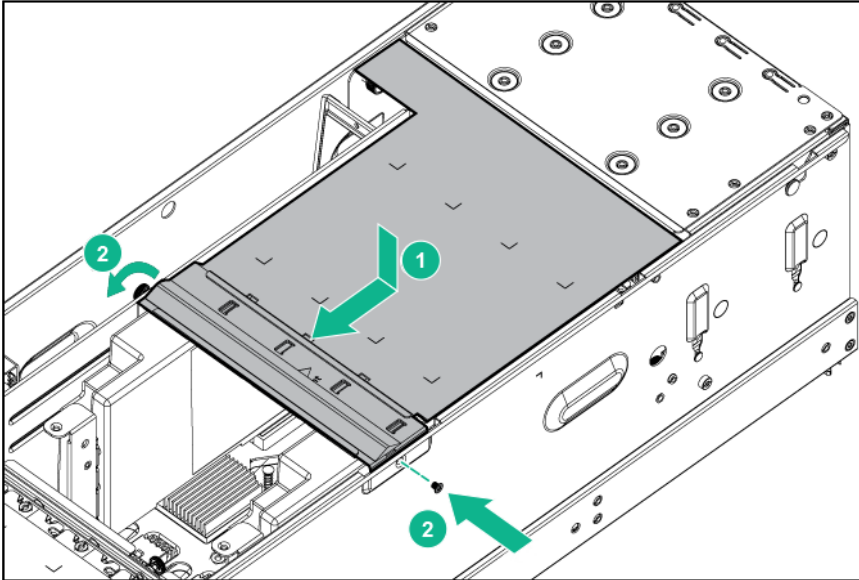

11. Install the shipping brackets and shipping plates (on page 18).
12. Install the server into the chassis ("Installing the server into the chassis" on page 30).
13. Connect the peripheral cables.
14. Power up the server (on page 14).

Processor option

To install the component:

1. Update the system ROM.
Locate and download the latest ROM version from the Hewlett Packard Enterprise Support Center website (<http://www.hpe.com/support/hpesc>). Follow the instructions on the website to update the system ROM.
2. Power down the server (on page 14).
3. Remove the server from the chassis (on page 14).
4. Place the server on a flat, level work surface.
5. Remove the shipping brackets and shipping plates (on page 16).
6. Remove the SFF hot-plug drive cage ("Remove the hot-plug SFF drive cage" on page 15).
7. Remove the GPU cage (on page 19).



WARNING: To reduce the risk of personal injury from hot surfaces, allow the drives and the internal system components to cool before touching them.



CAUTION: To prevent possible server malfunction and damage to the equipment, multiprocessor configurations must contain processors with the same part number.



CAUTION: The heatsink thermal interface media is not reusable and must be replaced if the heatsink is removed from the processor after it has been installed.



CAUTION: To prevent possible server overheating, always populate processor socket 2 with a processor and a heatsink or a processor socket cover and a heatsink blank.



IMPORTANT: Processor socket 1 must be populated at all times or the server does not function.

8. Remove the processor air baffle (on page 23).
9. Open each of the processor locking levers in the order indicated, and then open the processor retaining bracket.

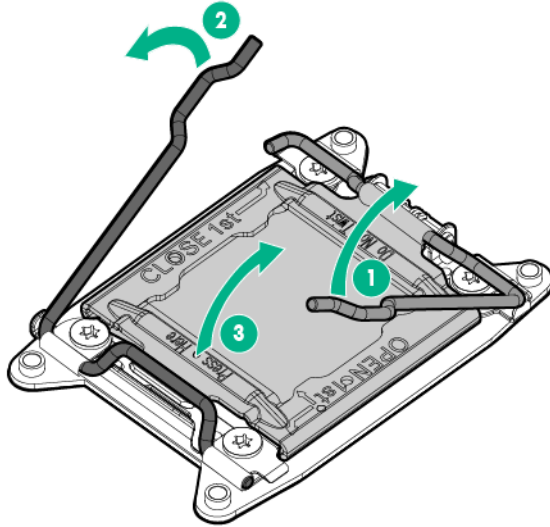

10. Remove the clear processor socket cover. Retain the processor socket cover for future use.

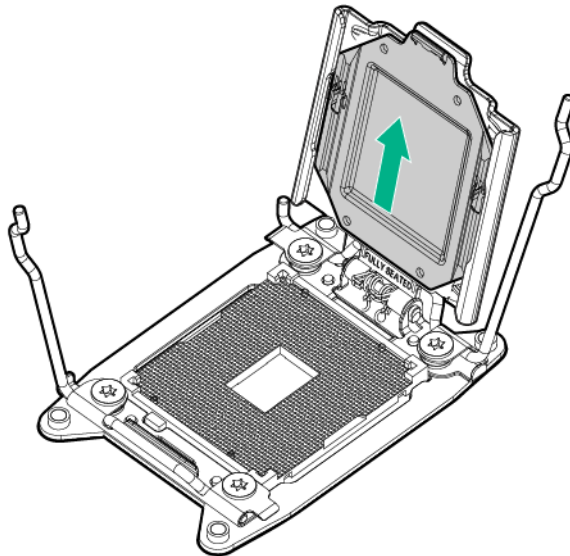

11. Install the processor. Verify that the processor is fully seated in the processor retaining bracket by visually inspecting the processor installation guides on either side of the processor. **THE PINS ON THE SYSTEM BOARD ARE VERY FRAGILE AND EASILY DAMAGED.**

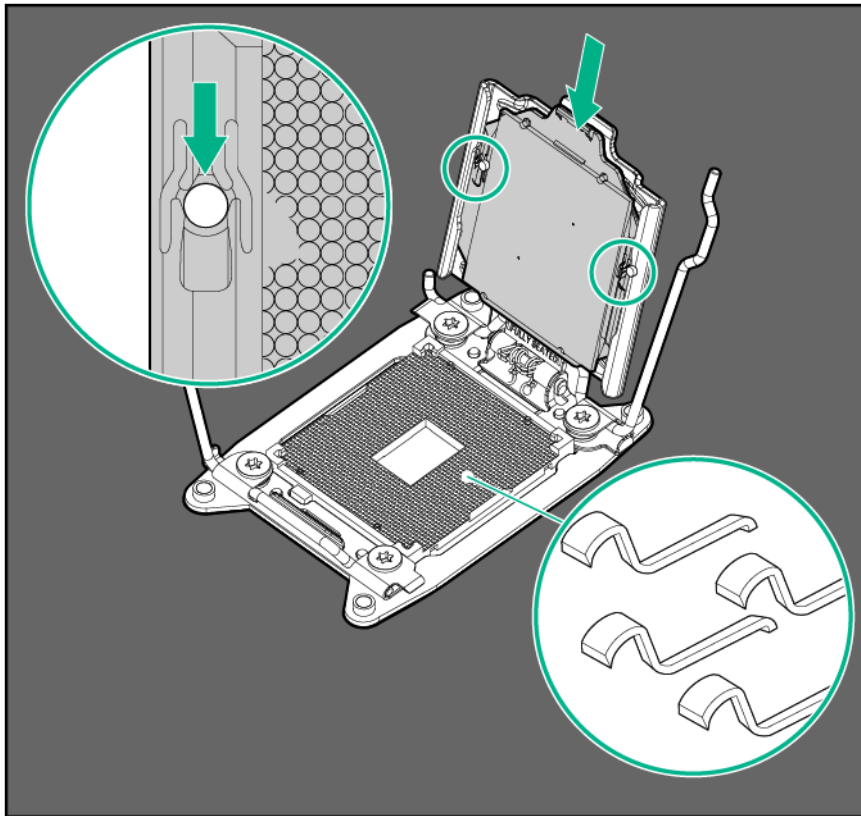

CAUTION: THE PINS ON THE SYSTEM BOARD ARE VERY FRAGILE AND EASILY DAMAGED. To avoid damage to the system board, do not touch the processor or the processor socket contacts.

12. Close the processor retaining bracket. When the processor is installed properly inside the processor retaining bracket, the processor retaining bracket clears the flange on the front of the socket.



CAUTION: Do not press down on the processor. Pressing down on the processor may cause damage to the processor socket and the system board. Press only in the area indicated on the processor retaining bracket.

13. Press and hold the processor retaining bracket in place, and then close each processor locking lever. Press only in the area indicated on the processor retaining bracket.

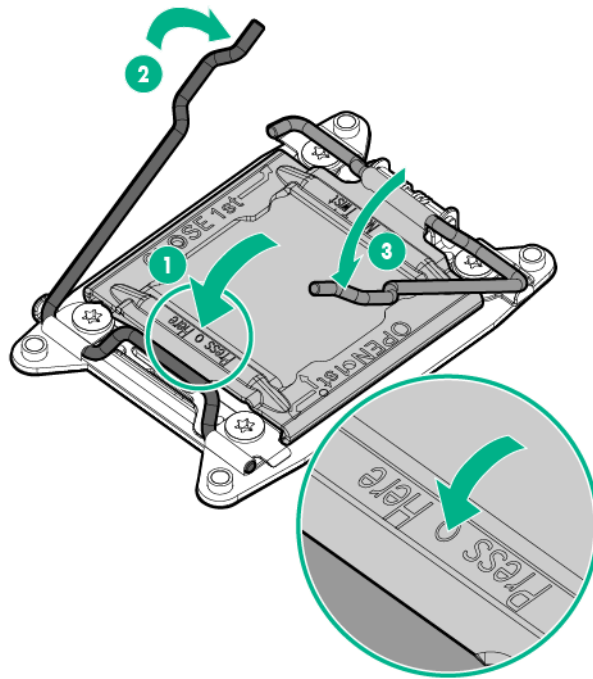

14. Remove the thermal interface protective cover from the heatsink.

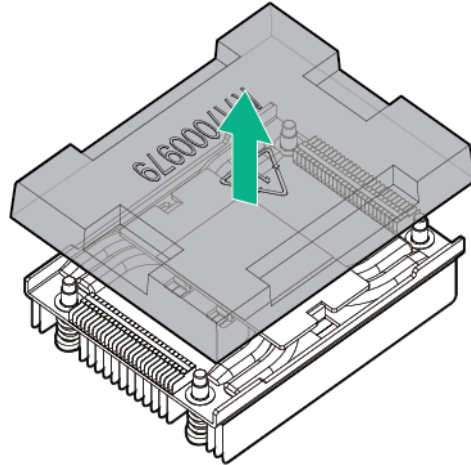

CAUTION: Heatsinks specified for processor 1 and 2 are not interchangeable. Be sure to note the appropriate orientation on the heatsink label.

CAUTION: Heatsink retaining screws should be tightened or loosened in diagonally opposite pairs (in an "X" pattern). Do not overtighten the screws as this can damage the board, connectors, or screws. Use the wrench supplied with the system to reduce the possibility of overtightening the screws.

15. Install the heatsink:
 - a. Position the heatsink on the processor backplate.

- b. Tighten one pair of diagonally opposite screws halfway, and then tighten the other pair of screws.
- c. Finish the installation by completely tightening the screws in the same sequence.

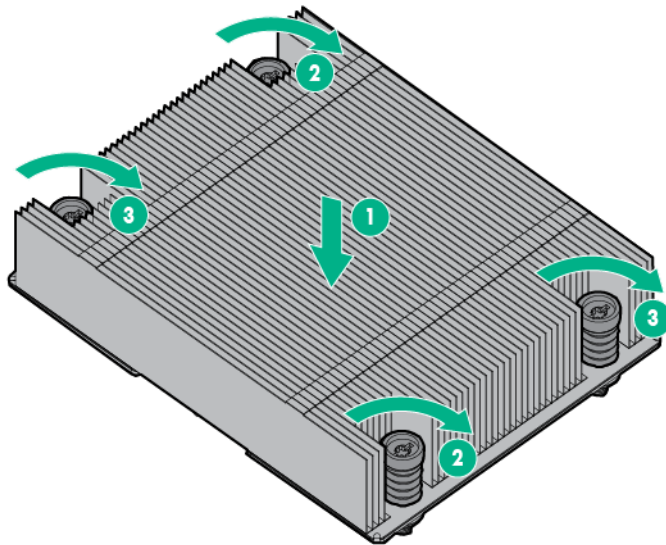

16. Install the processor air baffle (on page 23).
17. Install the GPU cage (on page 22)
18. Install the SFF hot-plug drive cage ("Install the hot-plug SFF drive cage" on page 16).
19. Install the shipping brackets and shipping plates (on page 18).
20. Install the server into the chassis ("Installing the server into the chassis" on page 30).
21. Power up the server (on page 14).

Memory options



IMPORTANT: This server does not support mixing RDIMMs and UDIMMs. Attempting to mix any combination of these DIMMs can cause the server to halt during BIOS initialization.

The memory subsystem in this server can support RDIMMs or UDIMMs. Both types are referred to as DIMMs when the information applies to all three types. When specified as RDIMM or UDIMM, the information applies to that type only. All memory installed in the server must be the same type.

The server supports the following DIMM speeds:

- Single-rank and dual-rank PC3-12800 (DDR3-1600) DIMMs operating at 1600, 1333, and 1066 MHz
- Single-rank and dual-rank PC3-10600 (DDR3-1333) DIMMs operating at 1333 and 1066 MHz
- Quad-rank PC3-14900L (DDR3-1866) LRDIMMs operating at 1866 MHz

Depending on the processor model, the number of DIMMs installed, and whether UDIMMs or RDIMMs are installed, the memory clock speed might be reduced to 1333, 1066 or 800 MHz. For more information on the effect of DIMM slot population, see "General DIMM slot population guidelines."

HPE SmartMemory

HPE SmartMemory, introduced for Gen8 servers, authenticates and unlocks certain features available only on HPE Qualified memory and verifies whether installed memory has passed Hewlett Packard Enterprise qualification and test processes. Qualified memory is performance-tuned for HPE ProLiant and

BladeSystem servers and provides future enhanced support through HPE Active Health and manageability software.

Certain performance features are unique with SmartMemory. HPE SmartMemory 1.35V DDR3-1333 Registered memory is engineered to achieve the same performance level as 1.5V memory. For example, while the industry supports DDR3-1333 RDIMM at 1.5V, this Gen8 server supports DDR3-1333 RDIMM at 1.35V. This difference equates to up to 20% less power at the DIMM level with no performance penalty.

Memory subsystem architecture

The memory subsystem in this server is divided into channels. Each processor supports four channels, and each channel supports two DIMM slots, as shown in the following table.

Channel	Slot	Slot number
1	A	1
	E	2
2	B	3
	F	4
3	C	8
	G	7
4	D	6
	H	5

For the location of the slot numbers, see "DIMM slot locations (on page 10)."

This multi-channel architecture provides enhanced performance in Advanced ECC mode. This architecture also enables the Lockstep memory mode.

DIMM slots in this server are identified by number and by letter. Letters identify the population order. Slot numbers indicate the DIMM slot ID for spare replacement.

Single-, dual-, and quad-rank DIMMs

To understand and configure memory protection modes properly, an understanding of single-, dual-, and quad-rank DIMMs is helpful. Some DIMM configuration requirements are based on these classifications.

A single-rank DIMM has one set of memory chips that is accessed while writing to or reading from the memory. A dual-rank DIMM is similar to having two single-rank DIMMs on the same module, with only one rank accessible at a time. A quad-rank DIMM is, effectively, two dual-rank DIMMs on the same module. Only one rank is accessible at a time. The server memory control subsystem selects the proper rank within the DIMM when writing to or reading from the DIMM.

Dual- and quad-rank DIMMs provide the greatest capacity with the existing memory technology. For example, if current DRAM technology supports 8-GB single-rank DIMMs, a dual-rank DIMM would be 16 GB, and a quad-rank DIMM would be 32 GB.

LRDIMMs are labeled as quad-rank DIMMs; however, they function more like dual-rank DIMMs. There are four ranks of DRAM on the DIMM, but the LRDIMM buffer creates an abstraction that allows the DIMM to appear as a dual-rank DIMM to the system. The LRDIMM buffer also isolates the electrical loading of the DRAM from the system to allow for faster operation. These two changes allow the system to support up to three LRDIMMs per memory channel, providing for up to 50% greater memory capacity and higher memory operating speed compared to quad-rank RDIMMs.

DIMM identification

To determine DIMM characteristics, use the label attached to the DIMM and the following illustration and table.

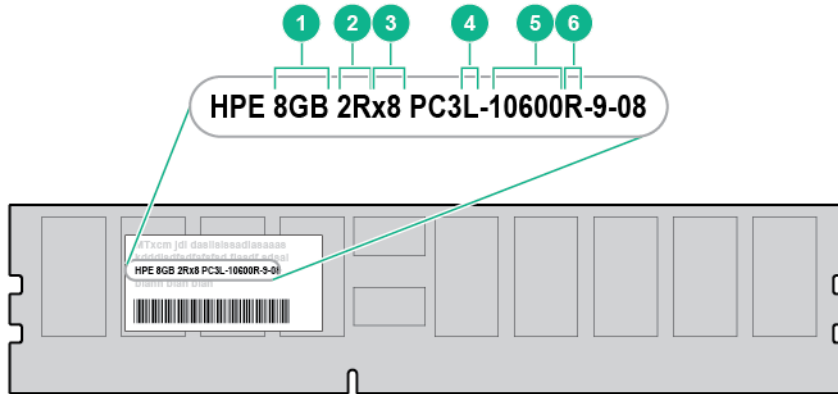

Item	Description	Definition
1	Size	—
2	Rank	1R = Single-rank 2R = Dual-rank 3R = Three-rank 4R = Quad-rank
3	Data width	x4 = 4-bit x8 = 8-bit
4	Voltage rating	L = Low voltage (1.35V) U = Ultra low voltage (1.25V) Blank or omitted = Standard
5	Memory speed	14900 = 1866-MT/s 12800 = 1600-MT/s 10600 = 1333-MT/s 8500 = 1066-MT/s
6	DIMM type	R = RDIMM (registered) E = UDIMM (unbuffered with ECC) L = LRDIMM (load reduced) H = HDIMM (HyperCloud)

Memory protection modes

To optimize server availability, the server supports the following AMP modes:

- **Advanced ECC**—Provides up to 4-bit error correction and enhanced performance over Lockstep memory mode. This mode is the default option for the server.
- **Online Spare Memory**—Provides protection against failing or degraded DIMMs. Certain memory is reserved as spare, and automatic failover to spare memory occurs when the system detects a DIMM that is degrading. This enables DIMMs that have a higher probability of receiving an uncorrectable memory error (which results in system downtime) to be removed from operation.

The server also can operate in independent channel mode or combined channel mode (Lockstep Memory mode). When running in Lockstep Memory mode, you gain reliability in one of two ways:

- If running with UDIMMs (built with x8 DRAM devices), the system can survive a complete DRAM failure (SDDC). In independent channel mode, this failure would be an uncorrectable error.
- If running with RDIMM (built with x4 DRAM devices), the system can survive the complete failure of two DRAM devices (DDDC). Running in independent mode, the server can only survive the complete failure of a single DRAM device (SDDC).

Advanced Memory Protection options are configured in RBSU. If the requested AMP mode is not supported by the installed DIMM configuration, the server boots in Advanced ECC mode. For more information, see "HPE ROM-Based Setup Utility (on page 81)."

Maximum memory configurations

The server supports a maximum of 256 GB of memory with one processor (8 x 32 GB), or 512 GB of memory with two processors (16 x 32 GB).

Advanced ECC memory configuration

Advanced ECC memory is the default memory protection mode for this server. Standard ECC can correct single-bit memory errors and detect multi-bit memory errors. When multi-bit errors are detected using Standard ECC, the error is signaled to the server and causes the server to halt.

Advanced ECC protects the server against some multi-bit memory errors. Advanced ECC can correct both single-bit memory errors and 4-bit memory errors if all failed bits are on the same DRAM device on the DIMM.

Advanced ECC provides additional protection over Standard ECC because it is possible to correct certain memory errors that would otherwise be uncorrected and result in a server failure. Using HPE Advanced Memory Error Detection technology, the server provides notification when a DIMM is degrading and has a higher probability of uncorrectable memory error.

Online Spare memory configuration

Online spare memory provides protection against degraded DIMMs by reducing the likelihood of uncorrected memory errors. This protection is available without any operating system support.

Online spare memory protection dedicates one rank of each memory channel for use as spare memory. The remaining ranks are available for OS and application use. If correctable memory errors occur at a rate higher than a specific threshold on any of the non-spare ranks, the server automatically copies the memory contents of the degraded rank to the online spare rank. The server then deactivates the failing rank and automatically switches over to the online spare rank.

Lockstep memory configuration

Lockstep mode provides protection against multi-bit memory errors that occur on the same DRAM device. Lockstep mode can correct any single DRAM device failure on x4 and x8 DIMM types. The DIMMs in each channel must have identical Hewlett Packard Enterprise part numbers.

Maximum capacity

DIMM type	DIMM rank	One processor	Two processors
RDIMM	Single-rank	64GB	128 GB
RDIMM	Dual-rank	128 GB	256 GB
UDIMM	Single-rank	16 GB	32 GB
UDIMM	Dual-rank	64 GB	128GB
LRDIMM	Quad-rank	256 GB	512 GB

General DIMM slot population guidelines

Observe the following guidelines for all AMP modes:

- Install DIMMs only if the corresponding processor is installed.
- When two processors are installed, balance the DIMMs across the two processors.
- White DIMM slots denote the first slot of a channel (Ch 1-A, Ch 2-B, Ch 3-C, Ch 4-D)
- Do not mix RDIMMs, UDIMMs, or LRDIMMs.
- When one processor is installed, install DIMMs in sequential alphabetic order: A, B, C, D, E, F, and so forth.
- When two processors are installed, install the DIMMs in sequential alphabetic order balanced between the two processors: P1-A, P2-A, P1-B, P2-B, P1-C, P2-C, and so forth.
- For DIMM spare replacement, install the DIMMs per slot number as instructed by the system software.

For detailed memory configuration rules and guidelines, use the Online DDR3 Memory Configuration Tool on the Hewlett Packard Enterprise website (<http://www.hpe.com/info/ddr3memory-configurator>).

The following DIMM speeds are supported in this server.

Populated slots (per channel)	Rank	Speeds supported (MHz)*	Speeds supported (MHz)**
1	Single or dual	1066, 1333, 1600	1333, 1600, 1866
2	Single or dual	1066, 1333, 1600	1333, 1600, 1866
1	Quad	-	1866
2	Quad	-	1866

*Intel Xeon Processor E5-2600 series

**Intel Xeon Processor E5-2600 v2 series

Advanced ECC population guidelines

For Advanced ECC mode configurations, observe the following guidelines:

- Observe the general DIMM slot population guidelines.
- DIMMs may be installed individually.

Online spare population

For Online Spare memory mode configurations, observe the following guidelines:

- Observe the general DIMM slot population guidelines.
- Each channel must have a valid online spare configuration.
- Each channel can have a different valid online spare configuration.
- Each populated channel must have a spare rank:
 - A single dual-rank DIMM is not a valid configuration.
 - LRDIMMs are treated as dual-rank DIMMs.

Lockstep Memory population guidelines

For Lockstep memory mode configurations, observe the following guidelines:

- Observe the general DIMM slot population guidelines.
- DIMM configuration on all channels of a processor must be identical.
- In multi-processor configurations, each processor must have a valid Lockstep Memory configuration.
- In multi-processor configurations, each processor may have a different valid Lockstep Memory configuration.

Population order

For memory configurations with a single processor or multiple processors, populate the DIMM sequentially in alphabetical order (A through H).

After installing the DIMMs, use RBSU to configure Advanced ECC, online spare, or lockstep memory support.

Installing a DIMM



CAUTION: To avoid damage to the drives, memory, and other system components, the air baffle, and drive blanks must be installed when the server is powered up.

1. Power down the server (on page 14).
2. Disconnect all peripheral cables from the server.
3. Remove the server from the chassis (on page 14).
4. Remove all shipping brackets.

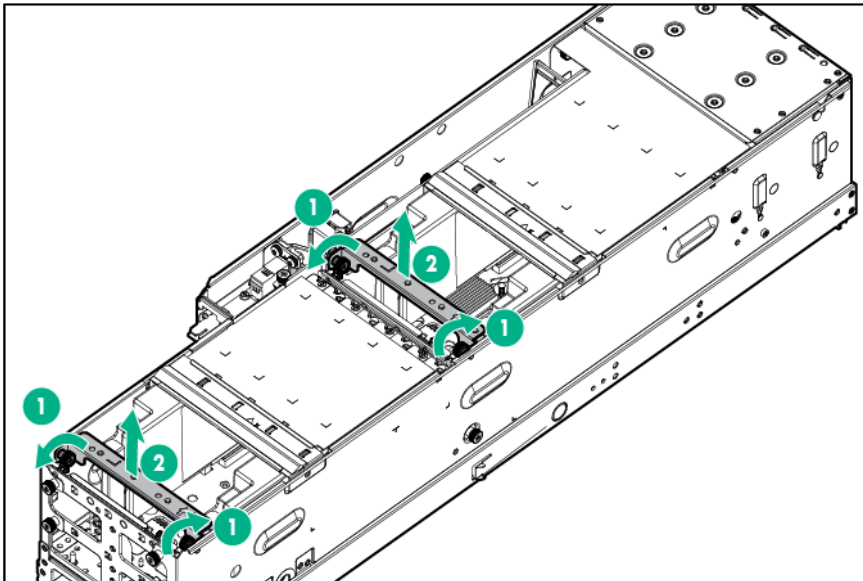

5. Remove the shipping plates.

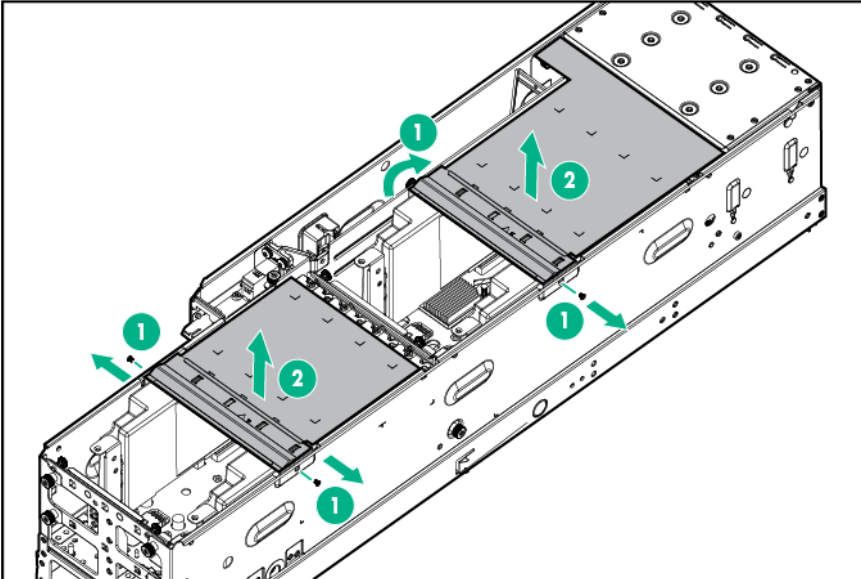

6. Remove the hard drive cage.

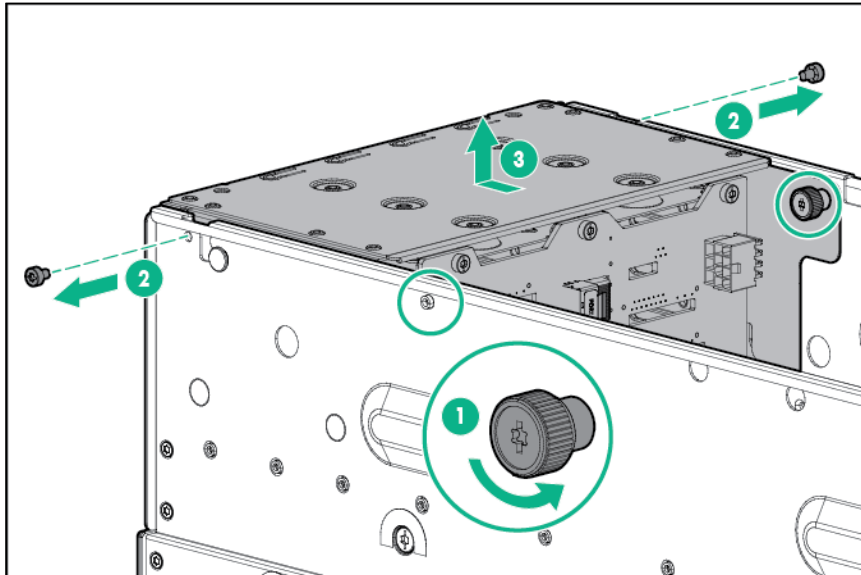

7. Loosen screws securing the GPU shelf.

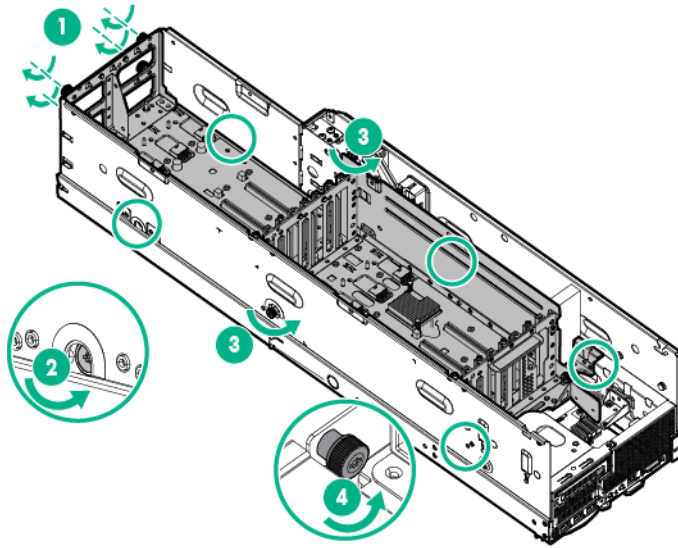

8. Remove the GPU shelf.

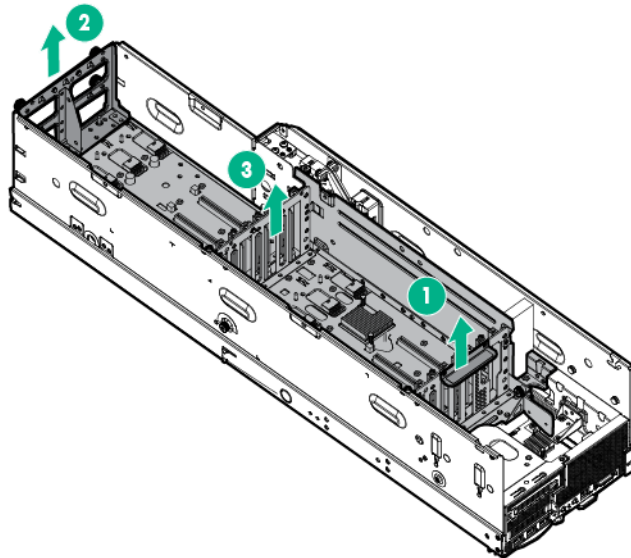

9. Remove the processor air baffle (on page 23).
10. Open the DIMM slot latches.

11. Install the DIMM.

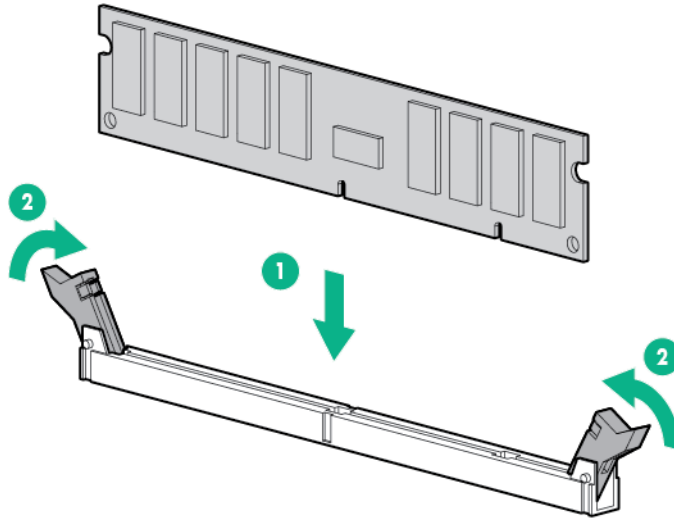

12. Install the processor air baffle (on page 23).
13. Install the GPU cage (on page 22)
14. Install the SFF hot-plug drive cage ("Install the hot-plug SFF drive cage" on page 16).
15. Install the shipping brackets and shipping plates (on page 18).
16. Install the server into the chassis ("Installing the server into the chassis" on page 30).
17. Power up the server (on page 14).

After installing the DIMMs, to configure memory protection mode, use RBSU ("HPE ROM-Based Setup Utility" on page 81).

HP Trusted Platform Module option

For more information about product features, specifications, options, configurations, and compatibility, see the product QuickSpecs on the Hewlett Packard Enterprise website (<http://www.hpe.com/info/qs>).

The TPM is not a customer-removable part.

CAUTION: Any attempt to remove an installed TPM from the system board breaks or disfigures the TPM security rivet. Upon locating a broken or disfigured rivet on an installed TPM, administrators should consider the system compromised and take appropriate measures to ensure the integrity of the system data.

If you suspect a TPM board failure, leave the TPM installed and remove the system board. Contact a Hewlett Packard Enterprise authorized service provider for a replacement system board and TPM board.

CAUTION: Always observe the guidelines in this document. Failure to follow these guidelines can cause hardware damage or halt data access.

When installing or replacing a TPM, observe the following guidelines:

- Do not remove an installed TPM. Once installed, the TPM becomes a permanent part of the system board.
- When installing or replacing hardware, Hewlett Packard Enterprise service providers cannot enable the TPM or the encryption technology. For security reasons, only the customer can enable these features.

- When returning a system board for service replacement, do not remove the TPM from the system board. When requested, Hewlett Packard Enterprise Service provides a TPM with the spare system board.
- Any attempt to remove an installed TPM from the system board breaks or disfigures the TPM security rivet. Upon locating a broken or disfigured rivet on an installed TPM, administrators should consider the system compromised and take appropriate measures to ensure the integrity of the system data.
- When using BitLocker, always retain the recovery key/password. The recovery key/password is required to enter Recovery Mode after BitLocker detects a possible compromise of system integrity.
- Hewlett Packard Enterprise is not liable for blocked data access caused by improper TPM use. For operating instructions, see the encryption technology feature documentation provided by the operating system.

Installing the Trusted Platform Module board



WARNING: To reduce the risk of personal injury, electric shock, or damage to the equipment, remove the power cord to remove power from the server. The front panel Power On/Standby button does not completely shut off system power. Portions of the power supply and some internal circuitry remain active until AC power is removed.



WARNING: To reduce the risk of personal injury from hot surfaces, allow the drives and the internal system components to cool before touching them.

1. Power down the server (on page 14).
2. Disconnect all peripheral cables from the server.
3. Remove the server from the chassis (on page 14).
4. Remove all shipping brackets.

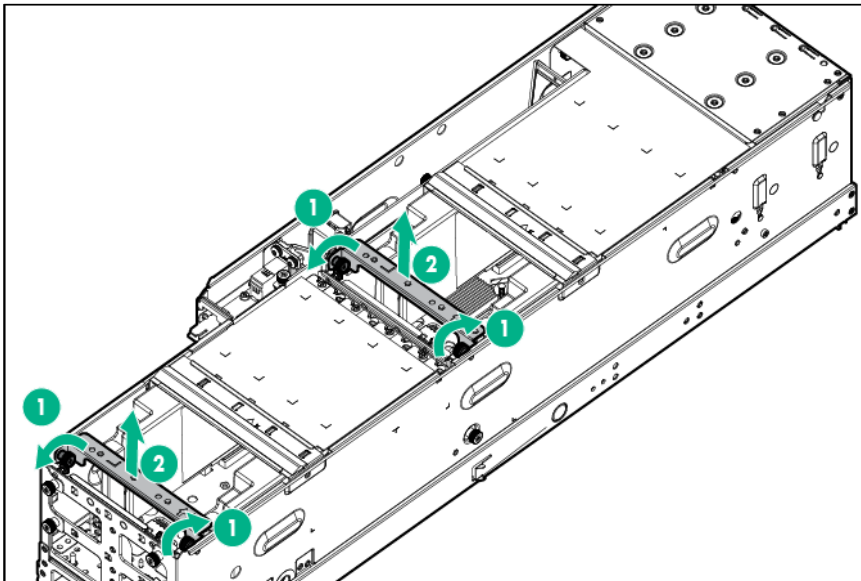

5. Remove the shipping plates.

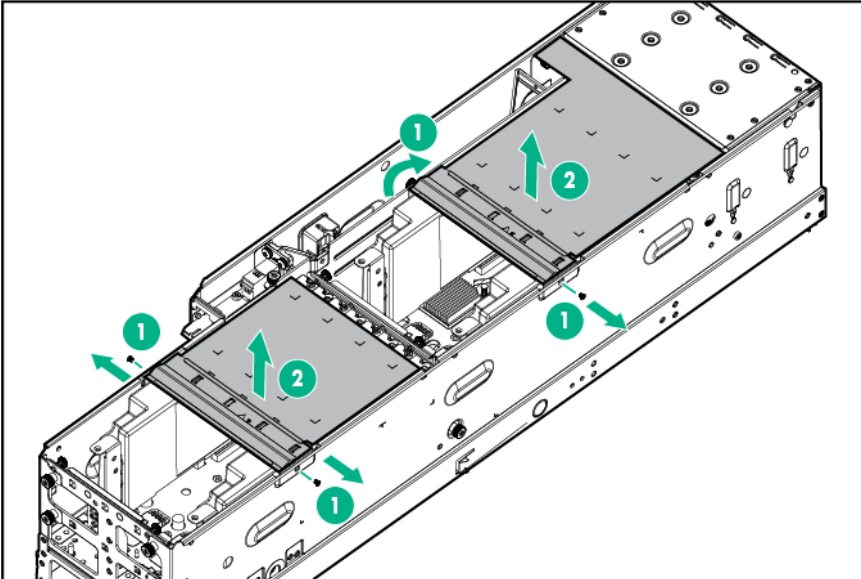

6. Remove the hard drive cage.

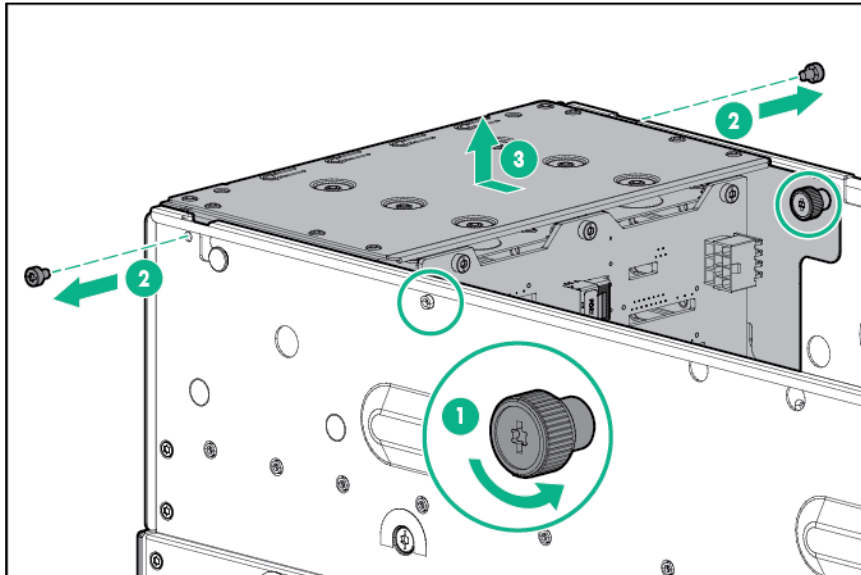

7. Loosen screws securing the GPU shelf.

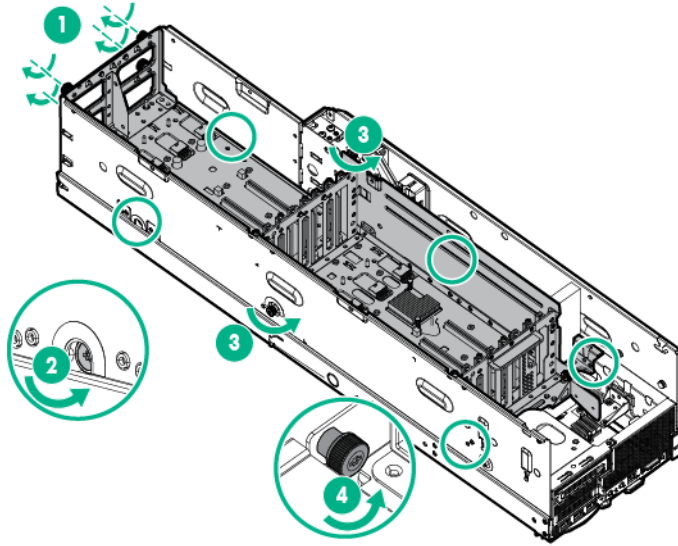

8. Remove the GPU shelf.

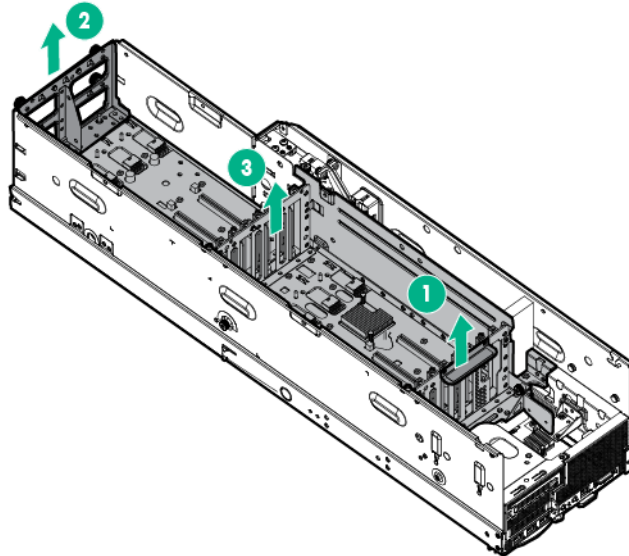

CAUTION: Any attempt to remove an installed TPM from the system board breaks or disfigures the TPM security rivet. Upon locating a broken or disfigured rivet on an installed TPM, administrators should consider the system compromised and take appropriate measures to ensure the integrity of the system data.

9. Install the TPM board. Press down on the connector to seat the board ("[System board components](#)" on page 9).

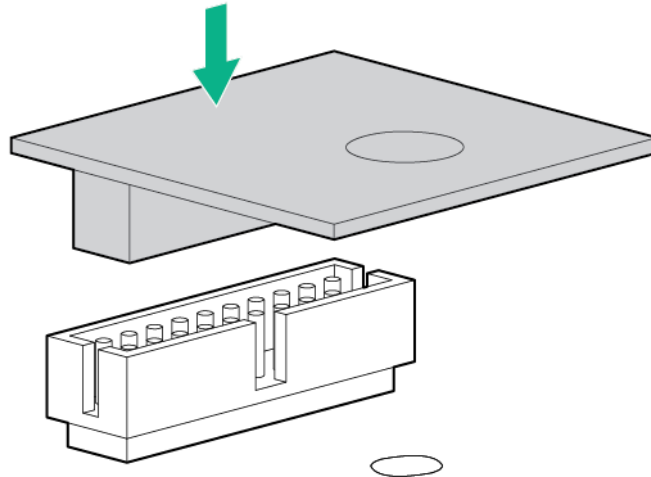

10. Install the TPM security rivet by pressing the rivet firmly into the system board.

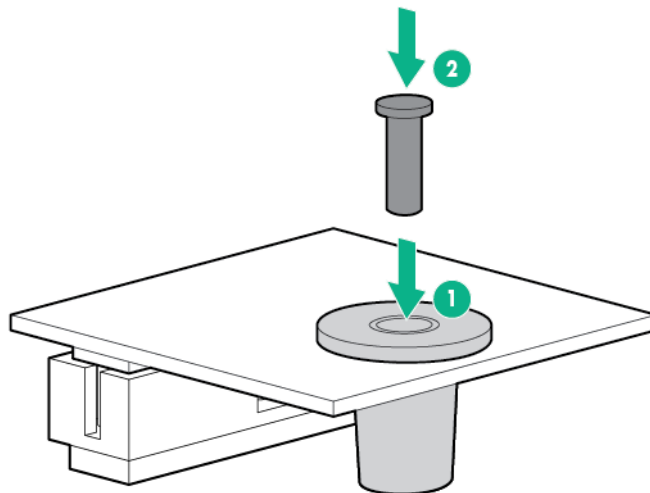

11. Install the GPU cage (on page 22)
12. Install the SFF hot-plug drive cage ("[Install the hot-plug SFF drive cage](#)" on page 16).
13. Install the shipping brackets and shipping plates (on page 18).
14. Install the server into the chassis ("[Installing the server into the chassis](#)" on page 30).
15. Connect the peripheral cables.
16. Power up the server (on page 14).

Retaining the recovery key/password

The recovery key/password is generated during BitLocker setup, and can be saved and printed after BitLocker is enabled. When using BitLocker, always retain the recovery key/password. The recovery key/password is required to enter Recovery Mode after BitLocker detects a possible compromise of system integrity.

To help ensure maximum security, observe the following guidelines when retaining the recovery key/password:

- Always store the recovery key/password in multiple locations.
- Always store copies of the recovery key/password away from the server.
- Do not save the recovery key/password on the encrypted hard drive.

Enabling the Trusted Platform Module

1. When prompted during the start-up sequence, access RBSU by pressing the **F9** key.
2. From the Main Menu, select **Server Security**.
3. From the Server Security Menu, select **Trusted Platform Module**.
4. From the Trusted Platform Module Menu, select **TPM Functionality**.
5. Select **Enable**, and then press the **Enter** key to modify the TPM Functionality setting.
6. Press the **Esc** key to exit the current menu, or press the **F10** key to exit RBSU.
7. Reboot the server.
8. Enable the TPM in the OS. For OS-specific instructions, see the OS documentation.



CAUTION: When a TPM is installed and enabled on the server, data access is locked if you fail to follow the proper procedures for updating the system or option firmware, replacing the system board, replacing a hard drive, or modifying OS application TPM settings.

For more information on firmware updates and hardware procedures, see the *HP Trusted Platform Module Best Practices White Paper* on the Hewlett Packard Enterprise website (<http://www.hpe.com/support/hpesc>).

For more information on adjusting TPM usage in BitLocker™, see the Microsoft website (<http://technet.microsoft.com/en-us/library/cc732774.aspx>).

Cabling

Cabling overview

This section provides guidelines that help you make informed decisions about cabling the server and hardware options to optimize performance.

For information on cabling peripheral components, refer to the white paper on high-density deployment at the Hewlett Packard Enterprise website (<http://www.hpe.com/products/servers/platforms>).

CAUTION: When routing cables, always be sure that the cables are not in a position where they can be pinched or crimped.

GPU cabling

- GPU power cabling

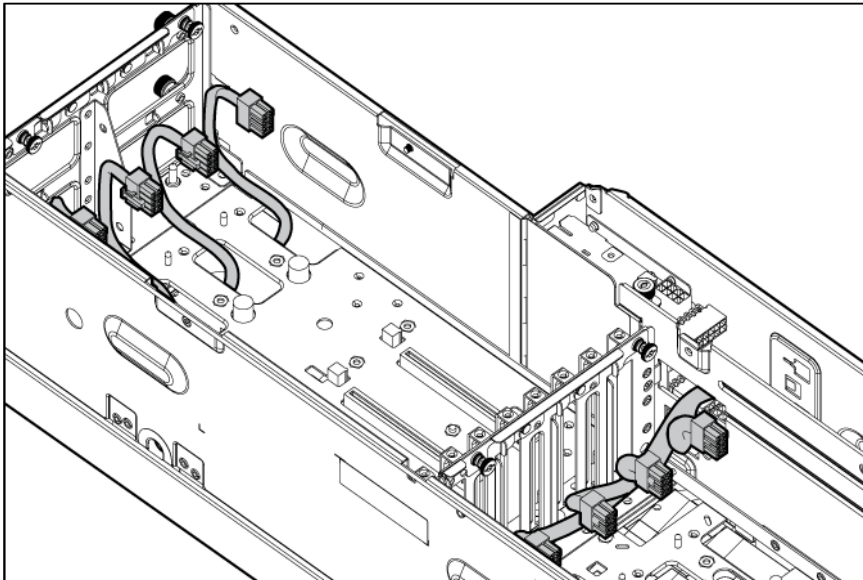

- GPU cage cabling

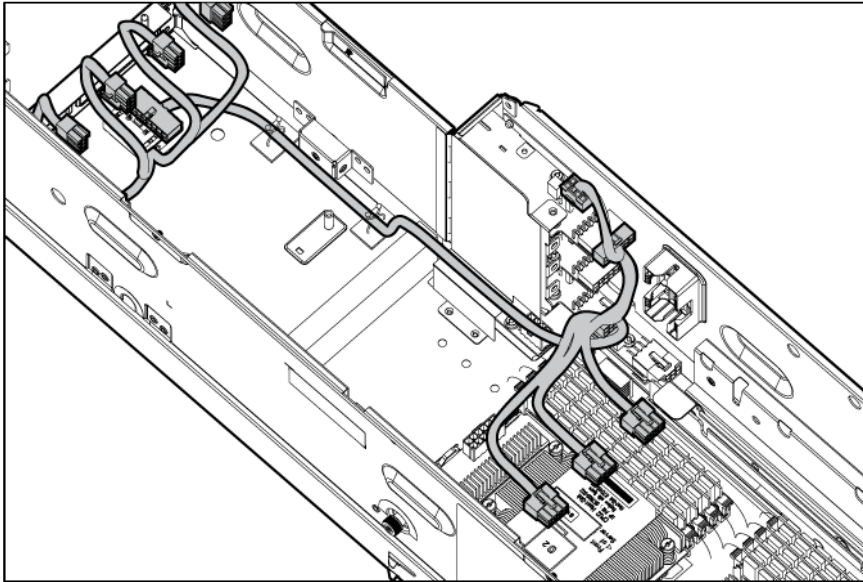

Front drive cage cabling

- Front drive cabling to system board and power

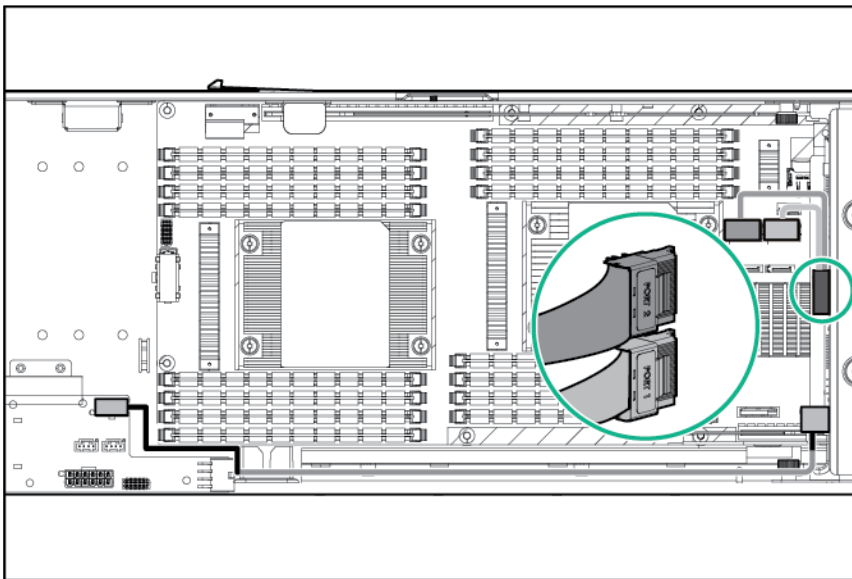

- Front drive cabling to controller card and power:

- Left node

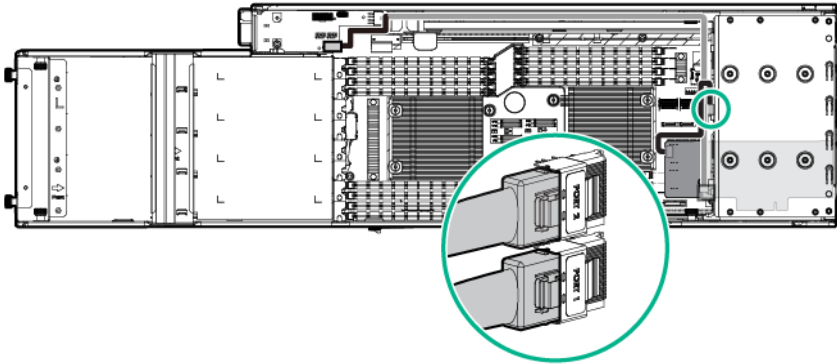

- Right node

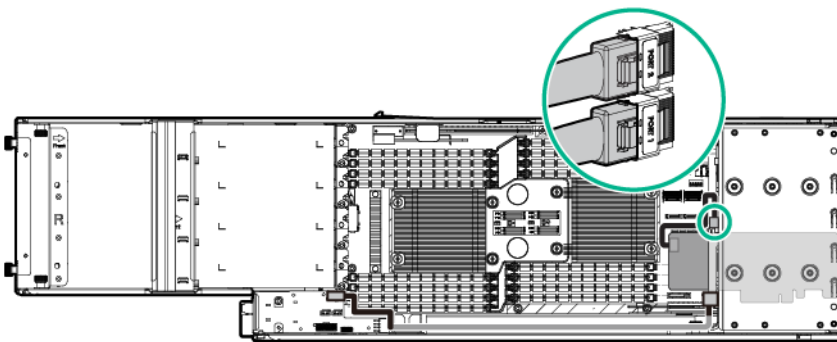

FBWC capacitor pack cabling

- Left node

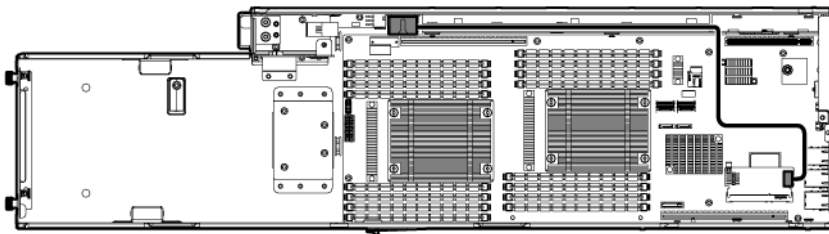

- Right node

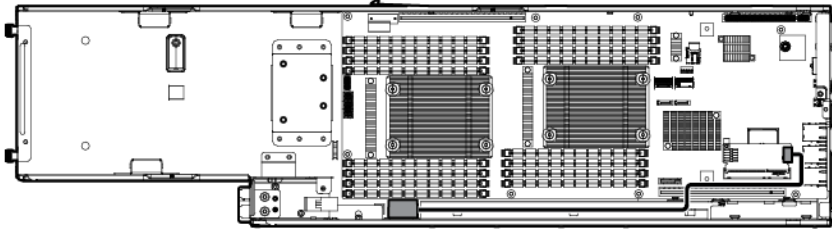

- Capacitor pack to FBWC on controller card cabling:
 - Left node

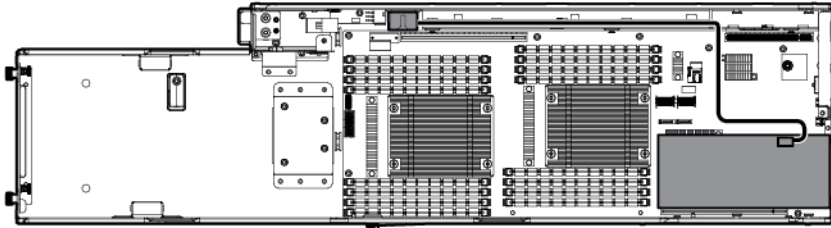

- Right node

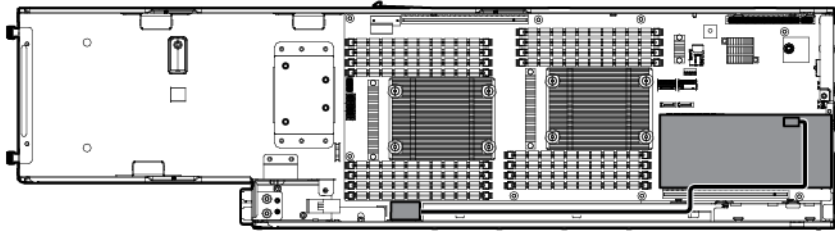

Personality board cabling

- Left node

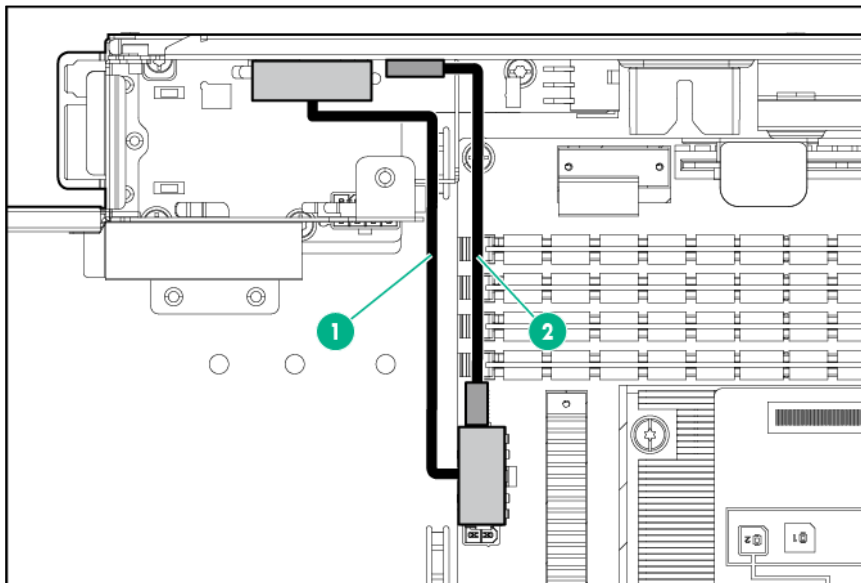

Item	Description
1	System board power cable
2	RPS cable

- Right node

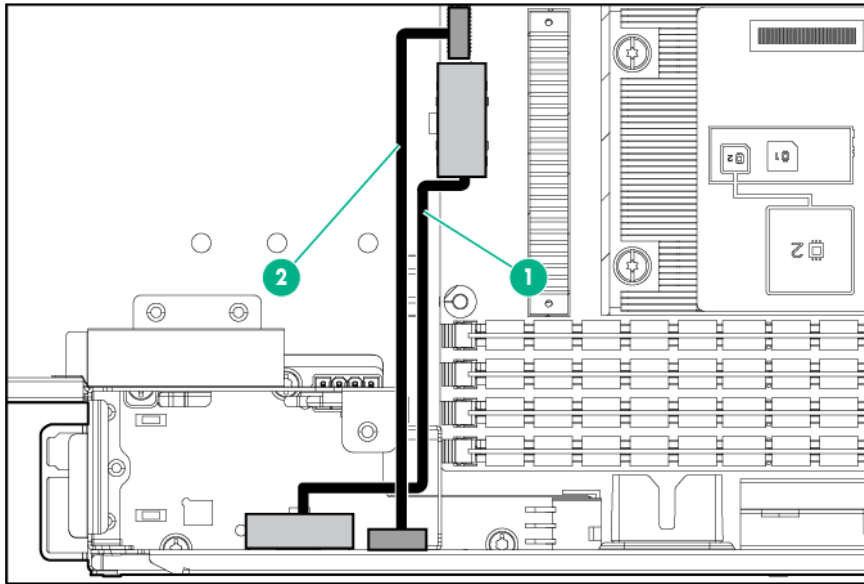

Item	Description
1	System board power cable
2	RPS cable

Software and configuration utilities

Server mode

The software and configuration utilities presented in this section operate in online mode, offline mode, or in both modes.

Software or configuration utility	Server mode
HPE iLO (on page 77)	Online and Offline
Active Health System (on page 78)	Online and Offline
Integrated Management Log (on page 79)	Online and Offline
Intelligent Provisioning (on page 79)	Offline
Insight Diagnostics ("HPE Insight Diagnostics" on page 79)	Online and Offline
Insight Remote Support software ("HPE Insight Remote Support software" on page 80)	Online
Insight Online (on page 80)	Online
Erase Utility (on page 80)	Offline
Scripting Toolkit ("Scripting Toolkit for Windows and Linux" on page 81)	Online
Service Pack for ProLiant (on page 81)	Online and Offline
Smart Update Manager ("HP Smart Update Manager" on page 81)	Online and Offline
ROM-Based Setup Utility ("HPE ROM-Based Setup Utility" on page 81)	Offline
HPE Smart Storage Administrator (on page 84)	Online and Offline
Option ROM Configuration for Arrays (on page 84)	Offline
ROMPaq utility (on page 84)	Offline

Hewlett Packard Enterprise product QuickSpecs

For more information about product features, specifications, options, configurations, and compatibility, see the product QuickSpecs on the Hewlett Packard Enterprise website (<http://www.hpe.com/info/qs>).

HPE iLO Management

HPE iLO Management is a set of embedded management features supporting the complete lifecycle of the server, from initial deployment through ongoing management.

HPE iLO

The iLO 4 subsystem is a standard component of ProLiant servers that simplifies initial server setup, server health monitoring, power and thermal optimization, and remote server administration. The iLO 4 subsystem includes an intelligent microprocessor, secure memory, and a dedicated network interface. This design makes iLO 4 independent of the host server and its operating system.

iLO 4 enables and manages the Active Health System (on page 78) and also features Agentless Management. All key internal subsystems are monitored by iLO 4. If enabled, SNMP alerts are sent directly by iLO 4 regardless of the host operating system or even if no host operating system is installed.

Embedded remote support software is available on ProLiant Gen8 and later servers with iLO 4, regardless of the operating system software and without installing OS agents on the server.

Using iLO 4, you can do the following:

- Access a high-performance and secure Integrated Remote Console to the server from anywhere in the world if you have a network connection to the server.
- Use the shared .NET Integrated Remote Console to collaborate with up to four server administrators.
- Remotely mount high-performance Virtual Media devices to the server.
- Securely and remotely control the power state of the managed server.
- Implement true Agentless Management with SNMP alerts from iLO, regardless of the state of the host server.
- Download the Active Health System log.
- Register for HPE Insight Remote Support.
- Use iLO Federation to manage multiple servers from one system running the iLO web interface.
- Use Virtual Power and Virtual Media from the GUI, the CLI, or the iLO scripting toolkit for many tasks, including the automation of deployment and provisioning.
- Control iLO by using a remote management tool.

For more information about iLO 4 features, see the iLO 4 documentation on the Hewlett Packard Enterprise website (<http://www.hpe.com/info/ilo/docs>).

Active Health System

The HPE Active Health System provides the following features:

- Combined diagnostics tools/scanners
- Always on, continuous monitoring for increased stability and shorter downtimes
- Rich configuration history
- Health and service alerts
- Easy export and upload to Service and Support

The Active Health System monitors and records changes in the server hardware and system configuration. The Active Health System assists in diagnosing problems and delivering rapid resolution if server failures occur.

The Active Health System collects the following types of data:

- Server model
- Serial number
- Processor model and speed
- Storage capacity and speed
- Memory capacity and speed
- Firmware/BIOS

Active Health System does not collect information about Active Health System users' operations, finances, customers, employees, partners, or data center, such as IP addresses, host names, user names, and passwords. Active Health System does not parse or change operating system data from third-party error event log activities, such as content created or passed through by the operating system.

The data that is collected is managed according to the Hewlett Packard Enterprise Data Privacy policy. For more information see the Hewlett Packard Enterprise website (<http://www.hpe.com/info/privacy>).

The Active Health System, in conjunction with the system monitoring provided by Agentless Management or SNMP Pass-thru, provides continuous monitoring of hardware and configuration changes, system status, and service alerts for various server components.

The Agentless Management Service is available in the SPP, which can be downloaded from the Hewlett Packard Enterprise website (<http://www.hpe.com/servers/spp/download>). The Active Health System log can be downloaded manually from iLO 4 or HPE Intelligent Provisioning and sent to Hewlett Packard Enterprise.

For more information, see the following documents:

- *iLO User Guide* on the Hewlett Packard Enterprise website (<http://www.hpe.com/info/enterprise/docs>)
- *Intelligent Provisioning User Guide* on the Hewlett Packard Enterprise website (<http://www.hpe.com/info/enterprise/docs>)

Integrated Management Log

The IML records hundreds of events and stores them in an easy-to-view form. The IML timestamps each event with 1-minute granularity.

You can view recorded events in the IML in several ways, including the following:

- From within HPE SIM
- From within operating system-specific IML viewers:
 - For Windows: IML Viewer
 - For Linux: IML Viewer Application
- From within the iLO 4 web interface
- From within Insight Diagnostics ("[HPE Insight Diagnostics](#)" on page 79)

Intelligent Provisioning

Intelligent Provisioning is a single-server deployment tool that is embedded in ProLiant Gen8 servers. It eliminates the need for SmartStart CDs and Smart Update Firmware DVDs. For more information about Intelligent Provisioning, see the *HPE Intelligent Provisioning User Guide* in the Information Library (<http://www.hpe.com/info/intelligentprovisioning/docs>).

HPE Insight Diagnostics

The Insight Diagnostics is a proactive server management tool, available in both offline and online versions, that provides diagnostics and troubleshooting capabilities to assist IT administrators who verify server installations, troubleshoot problems, and perform repair validation.

The Insight Diagnostics Offline Edition performs various in-depth system and component testing while the OS is not running. To run this utility, boot the server using Intelligent Provisioning (on page 79).

The Insight Diagnostics Online Edition is a web-based application that captures system configuration and other related data needed for effective server management. Available in Microsoft Windows and Linux versions, the utility helps to ensure proper system operation.

For more information or to download the utility, see the Hewlett Packard Enterprise website (<http://www.hpe.com/servers/diags>). The Insight Diagnostics Online Edition is also available in the SPP ("[Service Pack for ProLiant](#)" on page 81).

HPE Insight Diagnostics survey functionality

HPE Insight Diagnostics (on page 79) provides survey functionality that gathers critical hardware and software information on ProLiant servers.

This functionality supports operating systems that are supported by the server. For operating systems supported by the server, see the Hewlett Packard Enterprise website (<http://www.hpe.com/info/supportos>).

If a significant change occurs between data-gathering intervals, the survey function marks the previous information and overwrites the survey data files to reflect the latest changes in the configuration.

Survey functionality is installed with every Intelligent Provisioning-assisted HPE Insight Diagnostics installation, or it can be installed through the SPP ("[Service Pack for ProLiant](#)" on page 81).

Erase Utility



CAUTION: Perform a backup before running the Erase Utility. The utility sets the system to its original factory state, deletes the current hardware configuration information, including array setup and disk partitioning, and erases all connected hard drives completely. Before using this utility, see the instructions in the *Intelligent Provisioning User Guide*.

Use the Erase Utility to erase drives and Active Health System logs, and to reset RBSU settings. Run the Erase Utility if you must erase the system for the following reasons:

- You want to install a new operating system on a server with an existing operating system.
- You encounter an error when completing the steps of a factory-installed operating system installation.

To access the Erase Utility, click the Perform Maintenance icon from the Intelligent Provisioning home screen, and then select **Erase**.

For more information about the Erase Utility, see the Intelligent Provisioning user guide on the Hewlett Packard Enterprise website (<http://www.hpe.com/info/intelligentprovisioning/docs>).

HPE Insight Remote Support software

Hewlett Packard Enterprise strongly recommends that you register your device for remote support to enable enhanced delivery of your Hewlett Packard Enterprise Warranty, HP Care Pack Service, or Hewlett Packard Enterprise contractual support agreement. HPE Insight Remote Support supplements your monitoring continuously to ensure maximum system availability by providing intelligent event diagnosis, and automatic, secure submission of hardware event notifications to Hewlett Packard Enterprise, which will initiate a fast and accurate resolution, based on your product's service level. Notifications may be sent to your authorized Hewlett Packard Enterprise Channel Partner for onsite service, if configured and available in your country.

For more information, see *HPE Insight Remote Support and Insight Online Setup Guide for ProLiant Gen8 Servers and BladeSystem c-Class Enclosures* on the Hewlett Packard Enterprise website (<http://www.hpe.com/info/enterprise/docs>). Insight Remote Support is available as part of Hewlett Packard Enterprise Warranty, Care Pack Service, or Hewlett Packard Enterprise contractual support agreement.

Insight Online

HPE Insight Online is a capability of the Support Center portal. Combined with Insight Remote Support central connect or Insight Online direct connect, it automatically aggregates device health, asset, and support information with contract and warranty information, and then secures it in a single, personalized dashboard that is viewable from anywhere at any time. The dashboard organizes your IT and service data to help you understand and respond to that information more quickly. With specific authorization from you, an authorized Channel Partner can also view your IT environment remotely using Insight Online.

For more information about using Insight Online, see *Insight Online User's Guide* on the Hewlett Packard Enterprise website (<http://www.hpe.com/info/enterprise/docs>).

Scripting Toolkit for Windows and Linux

The Scripting Toolkit for Windows and Linux is a server deployment product that delivers an unattended automated installation for high-volume server deployments. The Scripting Toolkit is designed to support ProLiant BL, ML, DL, and SL servers. The toolkit includes a modular set of utilities and important documentation that describes how to apply these tools to build an automated server deployment process.

The Scripting Toolkit provides a flexible way to create standard server configuration scripts. These scripts are used to automate many of the manual steps in the server configuration process. This automated server configuration process cuts time from each deployment, making it possible to scale rapid, high-volume server deployments.

For more information, and to download the Scripting Toolkit, see the Hewlett Packard Enterprise website (<http://www.hpe.com/info/ProLiant/STK>).

Service Pack for ProLiant

The SPP is a comprehensive systems software (drivers and firmware) solution delivered as a single package with major server releases. This solution uses HP SUM as the deployment tool and is tested on all supported ProLiant servers including ProLiant Gen8 and later servers.

SPP can be used in an online mode on a Windows or Linux hosted operating system, or in an offline mode where the server is booted to an operating system included on the ISO file so that the server can be updated automatically with no user interaction or updated in interactive mode.

For more information or to download SPP, see one of the following pages on the Hewlett Packard Enterprise website:

- Service Pack for ProLiant download page (<http://www.hpe.com/info/spp/docs>)
- Smart Update: Server Firmware and Driver Updates page (<http://www.hpe.com/info/SmartUpdate/docs>)

HP Smart Update Manager

HP SUM is a product used to install and update firmware, drivers, and systems software on ProLiant servers. The HP SUM provides a GUI and a command-line scriptable interface for deployment of systems software for single or one-to-many ProLiant servers and network-based targets, such as iLOs, OAs, and VC Ethernet and Fibre Channel modules.

For more information about HP SUM, see the product page on the Hewlett Packard Enterprise website (<http://www.hpe.com/info/hpsum>).

To download HP SUM, see the Hewlett Packard Enterprise website (<http://www.hpe.com/info/hpsum/download>).

To access the *HP Smart Update Manager User Guide*, see the HP SUM Information Library (<http://www.hpe.com/info/hpsum/documentation>).

HPE ROM-Based Setup Utility

RBSU is a configuration utility embedded in HPE ProLiant servers that performs a wide range of configuration activities that can include the following:

- Configuring system devices and installed options
- Enabling and disabling system features
- Displaying system information
- Selecting the primary boot controller

- Configuring memory options
- Language selection

For more information on RBSU, see the *HPE ROM-Based Setup Utility User Guide* on the RBSU Information Library (<http://www.hpe.com/info/rbsu/docs>).

Using RBSU

To use RBSU, use the following keys:

- To access RBSU, press the **F9** key during power-up when prompted.
- To navigate the menu system, use the arrow keys.
- To make selections, press the **Enter** key.
- To access Help for a highlighted configuration option, press the **F1** key.



IMPORTANT: RBSU automatically saves settings when you press the **Enter** key. The utility does not prompt you for confirmation of settings before you exit the utility. To change a selected setting, you must select a different setting and press the **Enter** key.

Default configuration settings are applied to the server at one of the following times:

- Upon the first system power-up
- After defaults have been restored

Default configuration settings are sufficient for proper typical server operation, but configuration settings can be modified using RBSU. The system will prompt you for access to RBSU with each power-up.

Auto-configuration process

The auto-configuration process automatically runs when you boot the server for the first time. During the power-up sequence, the system ROM automatically configures the entire system without needing any intervention. During this process, the ORCA utility, in most cases, automatically configures the array to a default setting based on the number of drives connected to the server.

NOTE: If the boot drive is not empty or has been written to in the past, ORCA does not automatically configure the array. You must run ORCA to configure the array settings.

NOTE: The server may not support all the following examples.

Drives installed	Drives used	RAID level
1	1	RAID 0
2	2	RAID 1
3, 4, 5, or 6	3, 4, 5, or 6	RAID 5
More than 6	0	None

To change any ORCA default settings and override the auto-configuration process, press the **F8** key when prompted.

For more information on RBSU, see the *HPE ROM-Based Setup Utility User Guide* on the RBSU Information Library (<http://www.hpe.com/info/rbsu/docs>).

Boot options

Near the end of the boot process, the boot options screen is displayed. This screen is visible for several seconds before the system attempts to boot from a supported boot device. During this time, you can do the following:

- Access RBSU by pressing the **F9** key.
- Access Intelligent Provisioning Maintenance Menu by pressing the **F10** key.
- Access the boot menu by pressing the **F11** key.
- Force a PXE Network boot by pressing the **F12** key.

Configuring AMP modes

Not all ProLiant servers support all AMP modes. RBSU provides menu options only for the modes supported by the server. Advanced memory protection within RBSU enables the following advanced memory modes:

- **Advanced ECC Mode**—Provides memory protection beyond Standard ECC. All single-bit failures and some multi-bit failures can be corrected without resulting in system downtime.
- **Online Spare Mode**—Provides protection against failing or degraded DIMMs. Certain memory is set aside as spare, and automatic failover to spare memory occurs when the system detects a degraded DIMM. DIMMs that are likely to receive a fatal or uncorrectable memory error are removed from operation automatically, resulting in less system downtime.

For DIMM population requirements, see the server-specific user guide.

Re-entering the server serial number and product ID

After you replace the system board, you must re-enter the server serial number and the product ID.

1. During the server startup sequence, press the **F9** key to access RBSU.
2. Select the **Advanced Options** menu.
3. Select **Service Options**.
4. Select **Serial Number**. The following warning appears:

```
Warning: The serial number should ONLY be modified by qualified service
personnel. This value should always match the serial number located on the
chassis.
```
5. Press the **Enter** key to clear the warning.
6. Enter the serial number and press the **Enter** key.
7. Select **Product ID**. The following warning appears:

```
Warning: The Product ID should ONLY be modified by qualified service
personnel. This value should always match the Product ID located on the
chassis.
```
8. Enter the product ID and press the **Enter** key.
9. Press the **Esc** key to close the menu.
10. Press the **Esc** key to exit RBSU.
11. Press the **F10** key to confirm exiting RBSU. The server automatically reboots.

Utilities and features

HPE Smart Storage Administrator

The HPE SSA is a configuration and management tool for Smart Array controllers. Starting with ProLiant Gen8 servers, HPE SSA replaces ACU with an enhanced GUI and additional configuration features.

The HPE SSA exists in three interface formats: the HPE SSA GUI, the HPE SSA CLI, and HPE SSA Scripting. Although all formats provide support for configuration tasks, some of the advanced tasks are available in only one format.

Some HPE SSA features include the following:

- Supports online array capacity expansion, logical drive extension, assignment of online spares, and RAID or stripe size migration
- Suggests the optimal configuration for an unconfigured system
- Provides diagnostic and SmartSSD Wear Gauge functionality on the Diagnostics tab
- For supported controllers, provides access to additional features.

For more information about HPE SSA, see the Hewlett Packard Enterprise website (<http://www.hpe.com/info/hpessa>).

Option ROM Configuration for Arrays

Before installing an operating system, you can use the ORCA utility to create the first logical drive, assign RAID levels, and establish online spare configurations.

The utility also provides support for the following functions:

- Reconfiguring one or more logical drives
- Viewing the current logical drive configuration
- Deleting a logical drive configuration
- Setting the controller to be the boot controller
- Selecting the boot volume

If you do not use the utility, ORCA will default to the standard configuration.

For more information regarding the default configurations that ORCA uses, see the *ROM-Based Setup Utility User Guide* on the RBSU Information Library (<http://www.hpe.com/info/rbsu/docs>).

For more information about the storage controller and its features, select the relevant controller user documentation on the Hewlett Packard Enterprise website (http://www.hpe.com/support/SAC_UG_ProLiantServers_en).

To configure arrays, see the user guide for Smart Array Controllers on the Hewlett Packard Enterprise website (http://www.hpe.com/support/CASAC_RG_en).

ROMPaq utility

The ROMPaq utility enables you to upgrade the system firmware (BIOS). To upgrade the firmware, insert a ROMPaq USB Key into an available USB port and boot the system. In addition to ROMPaq, Online Flash Components for Windows and Linux operating systems are available for updating the system firmware.

The ROMPaq utility checks the system and provides a choice (if more than one exists) of available firmware revisions.

For more information, go to the Hewlett Packard Enterprise website (<http://www.hpe.com/support/hpesc>) and click on **Drivers, Software & Firmware**. Then, enter your product name in the **Select your HPE product** field and click **Go**.

Automatic Server Recovery

ASR is a feature that causes the system to restart when a catastrophic operating system error occurs, such as a blue screen, ABEND (does not apply to HPE ProLiant DL980 Servers), or panic. A system fail-safe timer, the ASR timer, starts when the System Management driver, also known as the Health Driver, is loaded. When the operating system is functioning properly, the system periodically resets the timer. However, when the operating system fails, the timer expires and restarts the server.

ASR increases server availability by restarting the server within a specified time after a system hang. At the same time, the SIM console notifies you by sending a message to a designated pager number that ASR has restarted the system. You can disable ASR from the System Management Homepage or through RBSU.

USB support

Hewlett Packard Enterprise provides both standard USB 2.0 support and legacy USB 2.0 support. Standard support is provided by the OS through the appropriate USB device drivers. Before the OS loads, Hewlett Packard Enterprise provides support for USB devices through legacy USB support, which is enabled by default in the system ROM.

Legacy USB support provides USB functionality in environments where USB support is not available normally. Specifically, Hewlett Packard Enterprise provides legacy USB functionality for the following:

- POST
- RBSU
- Diagnostics
- DOS
- Operating environments which do not provide native USB support

Redundant ROM support

The server enables you to upgrade or configure the ROM safely with redundant ROM support. The server has a single ROM that acts as two separate ROM images. In the standard implementation, one side of the ROM contains the current ROM program version, while the other side of the ROM contains a backup version.

NOTE: The server ships with the same version programmed on each side of the ROM.

Safety and security benefits

When you flash the system ROM, ROMPaq writes over the backup ROM and saves the current ROM as a backup, enabling you to switch easily to the alternate ROM version if the new ROM becomes corrupted for any reason. This feature protects the existing ROM version, even if you experience a power failure while flashing the ROM.

Keeping the system current

Drivers



IMPORTANT: Always perform a backup before installing or updating device drivers.

The server includes new hardware that may not have driver support on all OS installation media.

If you are installing an Intelligent Provisioning-supported OS, use Intelligent Provisioning (on page 79) and its Configure and Install feature to install the OS and latest supported drivers.

If you do not use Intelligent Provisioning to install an OS, drivers for some of the new hardware are required. These drivers, as well as other option drivers, ROM images, and value-add software can be downloaded as part of an SPP.

If you are installing drivers from SPP, be sure that you are using the latest SPP version that your server supports. To verify that your server is using the latest supported version and for more information about SPP, see the Hewlett Packard Enterprise website (<http://www.hpe.com/servers/spp/download>).

To locate the drivers for a particular server, go to the Hewlett Packard Enterprise Support Center website (<http://www.hpe.com/support/hpesc>). Under **Select your HPE product**, enter the product name or number and click **Go**.

Software and firmware

Software and firmware should be updated before using the server for the first time, unless any installed software or components require an older version.

For system software and firmware updates, use one of the following sources:

- Download the SPP ("Service Pack for ProLiant" on page 81) from the Service Pack for ProLiant download page (<http://www.hpe.com/info/spp/docs>).
- Download individual drivers, firmware, or other systems software components from the server product page in the Hewlett Packard Enterprise Support Center website (<http://www.hpe.com/support/hpesc>).

Version control

The VCRM and VCA are web-enabled Insight Management Agents tools that SIM uses to schedule software update tasks to the entire enterprise.

- VCRM manages the repository for SPP. Administrators can view the SPP contents or configure VCRM to automatically update the repository with internet downloads of the latest software and firmware from Hewlett Packard Enterprise.
- VCA compares installed software versions on the node with updates available in the VCRM managed repository. Administrators configure VCA to point to a repository managed by VCRM.

For more information about version control tools, see the *Systems Insight Manager User Guide*, the *Version Control Agent User Guide*, and the *Version Control Repository Manager User Guide* on the Hewlett Packard Enterprise website (<http://www.hpe.com/info/enterprise/docs>).

1. Select **HP Insight Management** from the available options in Products and Solutions.
2. Select **HP Version Control** from the available options in Insight Management.
3. Download the latest document.

Operating systems and virtualization software support for ProLiant servers

For information about specific versions of a supported operating system, see the Hewlett Packard Enterprise website (<http://www.hpe.com/info/ossupport>).

HPE Technology Service Portfolio

HPE Technology Services offers a targeted set of consultancy, deployment, and service solutions to meet the support needs of most business and IT environments.

Foundation Care services—Delivers scalable hardware and software support packages for ProLiant server and industry-standard software. You can choose the type and level of service that is most suitable for your business needs.

HPE Collaborative Support—With a single call, Hewlett Packard Enterprise addresses initial hardware and software support needs and helps to quickly identify if a problem is related to hardware or software. If the problem is related to hardware, Hewlett Packard Enterprise resolves the problem according to service level commitments. If the reported incident is related to a Hewlett Packard Enterprise software product or a supported third-party software product and cannot be resolved by applying known fixes, Hewlett Packard Enterprise contacts the third-party vendor and creates a problem incident on your behalf.

HPE Proactive Care—For customers running business critical environments where downtime is not an option, HPE Proactive Care helps to deliver high levels of availability. Key to these service options is the delivery of proactive service management tools to help you avoid the causes of downtime. If a problem arises, then Hewlett Packard Enterprise offers advanced technical response from critical system support specialists for problem identification and resolution.

Hewlett Packard Enterprise Support Center—For all service options, the Hewlett Packard Enterprise Support Center delivers the information, tools, and experts required to support Hewlett Packard Enterprise business products.

HPE Insight Remote Support—Provides 24x7 secure remote monitoring, diagnosis, and problem resolution.

For more information, see one of the following websites:

- ProLiant Server Services website (<http://www.hpe.com/services/proliant>)
- BladeSystem Services website (<http://www.hpe.com/services/bladeSystem>)

Change control and proactive notification

Hewlett Packard Enterprise offers Change Control and Proactive Notification to notify customers 30 to 60 days in advance of upcoming hardware and software changes on Hewlett Packard Enterprise commercial products.

For more information, refer to the Hewlett Packard Enterprise website (<http://www.hpe.com/info/pcn>).

Troubleshooting

Troubleshooting resources

The *ProLiant Gen8 Troubleshooting Guide, Volume I: Troubleshooting* provides procedures for resolving common problems and comprehensive courses of action for fault isolation and identification, issue resolution, and software maintenance on ProLiant servers and server blades. To view the guide, select a language:

- English (http://www.hpe.com/support/Gen9_TSG_en)
- French (http://www.hpe.com/support/Gen9_TSG_fr)
- Spanish (http://www.hpe.com/support/Gen9_TSG_es)
- German (http://www.hpe.com/support/Gen9_TSG_de)
- Japanese (http://www.hpe.com/support/Gen9_TSG_ja)
- Simplified Chinese (http://www.hpe.com/support/Gen9_TSG_zh_cn)

The *ProLiant Gen8 Troubleshooting Guide, Volume II: Error Messages* provides a list of error messages and information to assist with interpreting and resolving error messages on ProLiant servers and server blades. To view the guide, select a language:

- English (http://www.hpe.com/support/Gen9_EMG_en)
- French (http://www.hpe.com/support/Gen9_EMG_fr)
- Spanish (http://www.hpe.com/support/Gen9_EMG_es)
- German (http://www.hpe.com/support/Gen9_EMG_de)
- Japanese (http://www.hpe.com/support/Gen9_EMG_ja)
- Simplified Chinese (http://www.hpe.com/support/Gen9_EMG_zh_cn)

System battery

If the server no longer automatically displays the correct date and time, you might have to replace the battery that provides power to the real-time clock. Under normal use, battery life is 5 to 10 years.



WARNING: The computer contains an internal lithium manganese dioxide, a vanadium pentoxide, or an alkaline battery pack. A risk of fire and burns exists if the battery pack is not properly handled. To reduce the risk of personal injury:

- Do not attempt to recharge the battery.
- Do not expose the battery to temperatures higher than 60°C (140°F).
- Do not disassemble, crush, puncture, short external contacts, or dispose of in fire or water.
- Replace only with the spare designated for this product.

To remove the component:

1. Power down the server (on page 14).
2. Disconnect all peripheral cables from the server.
3. Remove the server from the chassis (on page 14).
4. Remove the front drive cage ("[Remove the hot-plug SFF drive cage](#)" on page 15).
5. Remove the shipping brackets ("[Remove the shipping brackets and shipping plates](#)" on page 16).
6. Remove the GPU cage.
7. If an expansion board is installed, remove the PCI riser cage ("[Remove the PCI/FlexibleLOM riser cage](#)" on page 24).
8. Locate the battery on the system board ("[System board components](#)" on page 9).
9. Remove the battery.

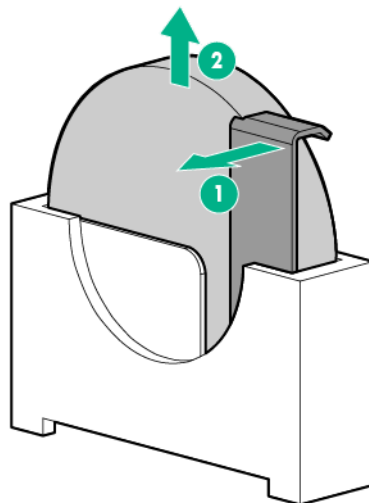

IMPORTANT: Replacing the system board battery resets the system ROM to its default configuration. After replacing the battery, reconfigure the system through RBSU.

To replace the component, reverse the removal procedure.

For more information about battery replacement or proper disposal, contact an authorized reseller or an authorized service provider.

Warranty and regulatory information

Warranty information

HPE ProLiant and x86 Servers and Options (<http://www.hpe.com/support/ProLiantServers-Warranties>)

HPE Enterprise Servers (<http://www.hpe.com/support/EnterpriseServers-Warranties>)

HPE Storage Products (<http://www.hpe.com/support/Storage-Warranties>)

HPE Networking Products (<http://www.hpe.com/support/Networking-Warranties>)

Regulatory information

Safety and regulatory compliance

For important safety, environmental, and regulatory information, see *Safety and Compliance Information for Server, Storage, Power, Networking, and Rack Products*, available at the Hewlett Packard Enterprise website (<http://www.hpe.com/support/Safety-Compliance-EnterpriseProducts>).

Turkey RoHS material content declaration

Türkiye Cumhuriyeti: EEE Yönetmeliğine Uygundur

Ukraine RoHS material content declaration

Обладнання відповідає вимогам Технічного регламенту щодо обмеження використання деяких небезпечних речовин в електричному та електронному обладнанні, затвердженого постановою Кабінету Міністрів України від 3 грудня 2008 № 1057

Electrostatic discharge

Preventing electrostatic discharge

To prevent damaging the system, be aware of the precautions you need to follow when setting up the system or handling parts. A discharge of static electricity from a finger or other conductor may damage system boards or other static-sensitive devices. This type of damage may reduce the life expectancy of the device.

To prevent electrostatic damage:

- Avoid hand contact by transporting and storing products in static-safe containers.
- Keep electrostatic-sensitive parts in their containers until they arrive at static-free workstations.
- Place parts on a grounded surface before removing them from their containers.
- Avoid touching pins, leads, or circuitry.
- Always be properly grounded when touching a static-sensitive component or assembly.

Grounding methods to prevent electrostatic discharge

Several methods are used for grounding. Use one or more of the following methods when handling or installing electrostatic-sensitive parts:

- Use a wrist strap connected by a ground cord to a grounded workstation or computer chassis. Wrist straps are flexible straps with a minimum of 1 megohm \pm 10 percent resistance in the ground cords. To provide proper ground, wear the strap snug against the skin.
- Use heel straps, toe straps, or boot straps at standing workstations. Wear the straps on both feet when standing on conductive floors or dissipating floor mats.
- Use conductive field service tools.
- Use a portable field service kit with a folding static-dissipating work mat.

If you do not have any of the suggested equipment for proper grounding, have an authorized reseller install the part.

For more information on static electricity or assistance with product installation, contact an authorized reseller.

Specifications

Environmental specifications

Specification	Value
Temperature range*	
Operating	10°C to 35°C (50°F to 95°F)
Shipping	-40°C to 70°C (-40°F to 158°F)
Maximum wet bulb temperature	28°C (82.4°F)
Relative humidity (noncondensing)**	
Operating	10% to 90%
Nonoperating	5% to 95%

* All temperature ratings shown are for sea level. An altitude derating of 1°C per 300 m (1.8°F per 1,000 ft) to 3,048 m (10,000 ft) is applicable. No direct sunlight allowed.

** Storage maximum humidity of 95% is based on a maximum temperature of 45°C (113°F). Altitude maximum for storage corresponds to a pressure minimum of 70 kPa.

Server specifications

Specification	Value
Height	16.82 cm (6.62 in)
Depth	81.91 cm (32.25 in)
Width	22.08 cm (8.69 in)
Weight (maximum: two processors, eight hard drives)	21.32 kg (47.00 lb)

Hot-plug power supply calculations

For hot-plug power supply specifications and calculators to determine electrical and heat loading for the server, see the Hewlett Packard Enterprise Power Advisor website (<http://www.hpe.com/info/rackandpower>).

Support and other resources

Accessing Hewlett Packard Enterprise Support

- For live assistance, go to the Contact Hewlett Packard Enterprise Worldwide website (<http://www.hpe.com/assistance>).
- To access documentation and support services, go to the Hewlett Packard Enterprise Support Center website (<http://www.hpe.com/support/hpesc>).

Information to collect

- Technical support registration number (if applicable)
- Product name, model or version, and serial number
- Operating system name and version
- Firmware version
- Error messages
- Product-specific reports and logs
- Add-on products or components
- Third-party products or components

Accessing updates

- Some software products provide a mechanism for accessing software updates through the product interface. Review your product documentation to identify the recommended software update method.
- To download product updates, go to either of the following:
 - Hewlett Packard Enterprise Support Center **Get connected with updates** page (<http://www.hpe.com/support/e-updates>)
 - Software Depot website (<http://www.hpe.com/support/softwaredepot>)
- To view and update your entitlements, and to link your contracts and warranties with your profile, go to the Hewlett Packard Enterprise Support Center **More Information on Access to Support Materials** page (<http://www.hpe.com/support/AccessToSupportMaterials>).



IMPORTANT: Access to some updates might require product entitlement when accessed through the Hewlett Packard Enterprise Support Center. You must have an HP Passport set up with relevant entitlements.

Websites

- Hewlett Packard Enterprise Information Library (<http://www.hpe.com/info/enterprise/docs>)
- Hewlett Packard Enterprise Support Center (<http://www.hpe.com/support/hpesc>)
- Contact Hewlett Packard Enterprise Worldwide (<http://www.hpe.com/assistance>)

- Subscription Service/Support Alerts (<http://www.hpe.com/support/e-updates>)
- Software Depot (<http://www.hpe.com/support/softwaredepot>)
- Customer Self Repair (<http://www.hpe.com/support/selfrepair>)
- Insight Remote Support (<http://www.hpe.com/info/insightremotesupport/docs>)
- Serviceguard Solutions for HP-UX (<http://www.hpe.com/info/hpux-serviceguard-docs>)
- Single Point of Connectivity Knowledge (SPOCK) Storage compatibility matrix (<http://www.hpe.com/storage/spock>)
- Storage white papers and analyst reports (<http://www.hpe.com/storage/whitepapers>)

Customer Self Repair

Hewlett Packard Enterprise products are designed with many Customer Self Repair (CSR) parts to minimize repair time and allow for greater flexibility in performing defective parts replacement. If during the diagnosis period Hewlett Packard Enterprise (or Hewlett Packard Enterprise service providers or service partners) identifies that the repair can be accomplished by the use of a CSR part, Hewlett Packard Enterprise will ship that part directly to you for replacement. There are two categories of CSR parts:

- **Mandatory**—Parts for which customer self repair is mandatory. If you request Hewlett Packard Enterprise to replace these parts, you will be charged for the travel and labor costs of this service.
- **Optional**—Parts for which customer self repair is optional. These parts are also designed for customer self repair. If, however, you require that Hewlett Packard Enterprise replace them for you, there may or may not be additional charges, depending on the type of warranty service designated for your product.

NOTE: Some Hewlett Packard Enterprise parts are not designed for customer self repair. In order to satisfy the customer warranty, Hewlett Packard Enterprise requires that an authorized service provider replace the part. These parts are identified as "No" in the Illustrated Parts Catalog.

Based on availability and where geography permits, CSR parts will be shipped for next business day delivery. Same day or four-hour delivery may be offered at an additional charge where geography permits. If assistance is required, you can call the Hewlett Packard Enterprise Support Center and a technician will help you over the telephone. Hewlett Packard Enterprise specifies in the materials shipped with a replacement CSR part whether a defective part must be returned to Hewlett Packard Enterprise. In cases where it is required to return the defective part to Hewlett Packard Enterprise, you must ship the defective part back to Hewlett Packard Enterprise within a defined period of time, normally five (5) business days. The defective part must be returned with the associated documentation in the provided shipping material. Failure to return the defective part may result in Hewlett Packard Enterprise billing you for the replacement. With a customer self repair, Hewlett Packard Enterprise will pay all shipping and part return costs and determine the courier/carrier to be used.

For more information about the Hewlett Packard Enterprise CSR program, contact your local service provider. For the North American program, go to the Hewlett Packard Enterprise CSR website (<http://www.hpe.com/support/selfrepair>).

Réparation par le client (CSR)

Les produits Hewlett Packard Enterprise comportent de nombreuses pièces CSR (Customer Self Repair = réparation par le client) afin de minimiser les délais de réparation et faciliter le remplacement des pièces défectueuses. Si pendant la période de diagnostic, Hewlett Packard Enterprise (ou ses partenaires ou mainteneurs agréés) détermine que la réparation peut être effectuée à l'aide d'une pièce CSR, Hewlett Packard Enterprise vous l'envoie directement. Il existe deux catégories de pièces CSR :

- **Obligatoire**—Pièces pour lesquelles la réparation par le client est obligatoire. Si vous demandez à Hewlett Packard Enterprise de remplacer ces pièces, les coûts de déplacement et main d'œuvre du service vous seront facturés.
- **Facultatif**—Pièces pour lesquelles la réparation par le client est facultative. Ces pièces sont également conçues pour permettre au client d'effectuer lui-même la réparation. Toutefois, si vous demandez à Hewlett Packard Enterprise de remplacer ces pièces, l'intervention peut ou non vous être facturée, selon le type de garantie applicable à votre produit.

REMARQUE: Certaines pièces Hewlett Packard Enterprise ne sont pas conçues pour permettre au client d'effectuer lui-même la réparation. Pour que la garantie puisse s'appliquer, Hewlett Packard Enterprise exige que le remplacement de la pièce soit effectué par un Mainteneur Agréé. Ces pièces sont identifiées par la mention "Non" dans le Catalogue illustré.

Les pièces CSR sont livrées le jour ouvré suivant, dans la limite des stocks disponibles et selon votre situation géographique. Si votre situation géographique le permet et que vous demandez une livraison le jour même ou dans les 4 heures, celle-ci vous sera facturée. Pour toute assistance, appelez le Centre d'assistance Hewlett Packard Enterprise pour qu'un technicien vous aide au téléphone. Dans les documents envoyés avec la pièce de rechange CSR, Hewlett Packard Enterprise précise s'il est nécessaire de lui retourner la pièce défectueuse. Si c'est le cas, vous devez le faire dans le délai indiqué, généralement cinq (5) jours ouvrés. La pièce et sa documentation doivent être retournées dans l'emballage fourni. Si vous ne retournez pas la pièce défectueuse, Hewlett Packard Enterprise se réserve le droit de vous facturer les coûts de remplacement. Dans le cas d'une pièce CSR, Hewlett Packard Enterprise supporte l'ensemble des frais d'expédition et de retour, et détermine la société de courses ou le transporteur à utiliser.

Pour plus d'informations sur le programme CSR de Hewlett Packard Enterprise, contactez votre Mainteneur Agréé local. Pour plus d'informations sur ce programme en Amérique du Nord, consultez le site Web Hewlett Packard Enterprise (<http://www.hpe.com/support/selfrepair>).

Riparazione da parte del cliente

Per abbreviare i tempi di riparazione e garantire una maggiore flessibilità nella sostituzione di parti difettose, i prodotti Hewlett Packard Enterprise sono realizzati con numerosi componenti che possono essere riparati direttamente dal cliente (CSR, Customer Self Repair). Se in fase di diagnostica Hewlett Packard Enterprise (o un centro di servizi o di assistenza Hewlett Packard Enterprise) identifica il guasto come riparabile mediante un ricambio CSR, Hewlett Packard Enterprise lo spedisce direttamente al cliente per la sostituzione. Vi sono due categorie di parti CSR:

- **Obbligatorie**—Parti che devono essere necessariamente riparate dal cliente. Se il cliente ne affida la riparazione ad Hewlett Packard Enterprise, deve sostenere le spese di spedizione e di manodopera per il servizio.
- **Opzionali**—Parti la cui riparazione da parte del cliente è facoltativa. Si tratta comunque di componenti progettati per questo scopo. Se tuttavia il cliente ne richiede la sostituzione ad Hewlett Packard Enterprise, potrebbe dover sostenere spese aggiuntive a seconda del tipo di garanzia previsto per il prodotto.

NOTA: alcuni componenti Hewlett Packard Enterprise non sono progettati per la riparazione da parte del cliente. Per rispettare la garanzia, Hewlett Packard Enterprise richiede che queste parti siano sostituite da un centro di assistenza autorizzato. Tali parti sono identificate da un "No" nel Catalogo illustrato dei componenti.

In base alla disponibilità e alla località geografica, le parti CSR vengono spedite con consegna entro il giorno lavorativo seguente. La consegna nel giorno stesso o entro quattro ore è offerta con un supplemento di costo solo in alcune zone. In caso di necessità si può richiedere l'assistenza telefonica di un addetto del centro di supporto tecnico Hewlett Packard Enterprise. Nel materiale fornito con una parte di ricambio CSR, Hewlett Packard Enterprise specifica se il cliente deve restituire dei componenti. Qualora sia richiesta la resa ad Hewlett Packard Enterprise del componente difettoso, lo si deve spedire ad Hewlett Packard Enterprise entro un determinato periodo di tempo, generalmente cinque (5) giorni lavorativi. Il componente difettoso deve essere restituito con la documentazione associata nell'imballo di

spedizione fornito. La mancata restituzione del componente può comportare la fatturazione del ricambio da parte di Hewlett Packard Enterprise. Nel caso di riparazione da parte del cliente, Hewlett Packard Enterprise sostiene tutte le spese di spedizione e resa e sceglie il corriere/vettore da utilizzare.

Per ulteriori informazioni sul programma CSR di Hewlett Packard Enterprise, contattare il centro di assistenza di zona. Per il programma in Nord America fare riferimento al sito Web (<http://www.hpe.com/support/selfrepair>).

Customer Self Repair

Hewlett Packard Enterprise Produkte enthalten viele CSR-Teile (Customer Self Repair), um Reparaturzeiten zu minimieren und höhere Flexibilität beim Austausch defekter Bauteile zu ermöglichen. Wenn Hewlett Packard Enterprise (oder ein Hewlett Packard Enterprise Servicepartner) bei der Diagnose feststellt, dass das Produkt mithilfe eines CSR-Teils repariert werden kann, sendet Ihnen Hewlett Packard Enterprise dieses Bauteil zum Austausch direkt zu. CSR-Teile werden in zwei Kategorien unterteilt:

- **Zwingend**—Teile, für die das Customer Self Repair-Verfahren zwingend vorgegeben ist. Wenn Sie den Austausch dieser Teile von Hewlett Packard Enterprise vornehmen lassen, werden Ihnen die Anfahrt- und Arbeitskosten für diesen Service berechnet.
- **Optional**—Teile, für die das Customer Self Repair-Verfahren optional ist. Diese Teile sind auch für Customer Self Repair ausgelegt. Wenn Sie jedoch den Austausch dieser Teile von Hewlett Packard Enterprise vornehmen lassen möchten, können bei diesem Service je nach den für Ihr Produkt vorgesehenen Garantiebedingungen zusätzliche Kosten anfallen.

HINWEIS: Einige Hewlett Packard Enterprise Teile sind nicht für Customer Self Repair ausgelegt. Um den Garantieanspruch des Kunden zu erfüllen, muss das Teil von einem Hewlett Packard Enterprise Servicepartner ersetzt werden. Im illustrierten Teilekatalog sind diese Teile mit „No“ bzw. „Nein“ gekennzeichnet.

CSR-Teile werden abhängig von der Verfügbarkeit und vom Lieferziel am folgenden Geschäftstag geliefert. Für bestimmte Standorte ist eine Lieferung am selben Tag oder innerhalb von vier Stunden gegen einen Aufpreis verfügbar. Wenn Sie Hilfe benötigen, können Sie das Hewlett Packard Enterprise Support Center anrufen und sich von einem Mitarbeiter per Telefon helfen lassen. Den Materialien von Hewlett Packard Enterprise, die mit einem CSR-Ersatzteil geliefert werden, können Sie entnehmen, ob das defekte Teil an Hewlett Packard Enterprise zurückgeschickt werden muss. Wenn es erforderlich ist, das defekte Teil an Hewlett Packard Enterprise zurückzuschicken, müssen Sie dies innerhalb eines vorgegebenen Zeitraums tun, in der Regel innerhalb von fünf (5) Geschäftstagen. Das defekte Teil muss mit der zugehörigen Dokumentation in der Verpackung zurückgeschickt werden, die im Lieferumfang enthalten ist. Wenn Sie das defekte Teil nicht zurückschicken, kann Hewlett Packard Enterprise Ihnen das Ersatzteil in Rechnung stellen. Im Falle von Customer Self Repair kommt Hewlett Packard Enterprise für alle Kosten für die Lieferung und Rücksendung auf und bestimmt den Kurier-/Frachtdienst.

Weitere Informationen über das Hewlett Packard Enterprise Customer Self Repair Programm erhalten Sie von Ihrem Servicepartner vor Ort. Informationen über das CSR-Programm in Nordamerika finden Sie auf der Hewlett Packard Enterprise Website unter (<http://www.hpe.com/support/selfrepair>).

Reparaciones del propio cliente

Los productos de Hewlett Packard Enterprise incluyen muchos componentes que el propio usuario puede reemplazar (Customer Self Repair, CSR) para minimizar el tiempo de reparación y ofrecer una mayor flexibilidad a la hora de realizar sustituciones de componentes defectuosos. Si, durante la fase de diagnóstico, Hewlett Packard Enterprise (o los proveedores o socios de servicio de Hewlett Packard Enterprise) identifica que una reparación puede llevarse a cabo mediante el uso de un componente CSR, Hewlett Packard Enterprise le enviará dicho componente directamente para que realice su sustitución. Los componentes CSR se clasifican en dos categorías:

- **Obligatorio**—componentes cuya reparación por parte del usuario es obligatoria. Si solicita a Hewlett Packard Enterprise que realice la sustitución de estos componentes, tendrá que hacerse cargo de los gastos de desplazamiento y de mano de obra de dicho servicio.
- **Opcional**—componentes cuya reparación por parte del usuario es opcional. Estos componentes también están diseñados para que puedan ser reparados por el usuario. Sin embargo, si precisa que Hewlett Packard Enterprise realice su sustitución, puede o no conllevar costes adicionales, dependiendo del tipo de servicio de garantía correspondiente al producto.

NOTA: Algunos componentes de Hewlett Packard Enterprise no están diseñados para que puedan ser reparados por el usuario. Para que el usuario haga valer su garantía, Hewlett Packard Enterprise pone como condición que un proveedor de servicios autorizado realice la sustitución de estos componentes. Dichos componentes se identifican con la palabra "No" en el catálogo ilustrado de componentes.

Según la disponibilidad y la situación geográfica, los componentes CSR se enviarán para que lleguen a su destino al siguiente día laborable. Si la situación geográfica lo permite, se puede solicitar la entrega en el mismo día o en cuatro horas con un coste adicional. Si precisa asistencia técnica, puede llamar al Centro de asistencia técnica de Hewlett Packard Enterprise y recibirá ayuda telefónica por parte de un técnico. Con el envío de materiales para la sustitución de componentes CSR, Hewlett Packard Enterprise especificará si los componentes defectuosos deberán devolverse a Hewlett Packard Enterprise. En aquellos casos en los que sea necesario devolver algún componente a Hewlett Packard Enterprise, deberá hacerlo en el periodo de tiempo especificado, normalmente cinco días laborables. Los componentes defectuosos deberán devolverse con toda la documentación relacionada y con el embalaje de envío. Si no enviara el componente defectuoso requerido, Hewlett Packard Enterprise podrá cobrarle por el de sustitución. En el caso de todas sustituciones que lleve a cabo el cliente, Hewlett Packard Enterprise se hará cargo de todos los gastos de envío y devolución de componentes y escogerá la empresa de transporte que se utilice para dicho servicio.

Para obtener más información acerca del programa de Reparaciones del propio cliente de Hewlett Packard Enterprise, póngase en contacto con su proveedor de servicios local. Si está interesado en el programa para Norteamérica, visite la página web de Hewlett Packard Enterprise CSR (<http://www.hpe.com/support/selfrepair>).

Customer Self Repair

Veel onderdelen in Hewlett Packard Enterprise producten zijn door de klant zelf te repareren, waardoor de reparatieduur tot een minimum beperkt kan blijven en de flexibiliteit in het vervangen van defecte onderdelen groter is. Deze onderdelen worden CSR-onderdelen (Customer Self Repair) genoemd. Als Hewlett Packard Enterprise (of een Hewlett Packard Enterprise Service Partner) bij de diagnose vaststelt dat de reparatie kan worden uitgevoerd met een CSR-onderdeel, verzendt Hewlett Packard Enterprise dat onderdeel rechtstreeks naar u, zodat u het defecte onderdeel daarmee kunt vervangen. Er zijn twee categorieën CSR-onderdelen:

- **Verplicht**—Onderdelen waarvoor reparatie door de klant verplicht is. Als u Hewlett Packard Enterprise verzoekt deze onderdelen voor u te vervangen, worden u voor deze service reiskosten en arbeidsloon in rekening gebracht.
- **Optioneel**—Onderdelen waarvoor reparatie door de klant optioneel is. Ook deze onderdelen zijn ontworpen voor reparatie door de klant. Als u echter Hewlett Packard Enterprise verzoekt deze onderdelen voor u te vervangen, kunnen daarvoor extra kosten in rekening worden gebracht, afhankelijk van het type garantieservice voor het product.

OPMERKING: Sommige Hewlett Packard Enterprise onderdelen zijn niet ontwikkeld voor reparatie door de klant. In verband met de garantievooraarden moet het onderdeel door een geautoriseerde Service Partner worden vervangen. Deze onderdelen worden in de geïllustreerde onderdelencatalogus aangemerkt met "Nee".

Afhankelijk van de leverbaarheid en de locatie worden CSR-onderdelen verzonden voor levering op de eerstvolgende werkdag. Levering op dezelfde dag of binnen vier uur kan tegen meerkosten worden aangeboden, indien dit mogelijk is gezien de locatie. Indien assistentie is gewenst, belt u het Hewlett Packard Enterprise Support Center om via de telefoon ondersteuning van een technicus te ontvangen.

Hewlett Packard Enterprise vermeldt in de documentatie bij het vervangende CSR-onderdeel of het defecte onderdeel aan Hewlett Packard Enterprise moet worden geretourneerd. Als het defecte onderdeel aan Hewlett Packard Enterprise moet worden teruggezonden, moet u het defecte onderdeel binnen een bepaalde periode, gewoonlijk vijf (5) werkdagen, retourneren aan Hewlett Packard Enterprise. Het defecte onderdeel moet met de bijbehorende documentatie worden geretourneerd in het meegeleverde verpakkingsmateriaal. Als u het defecte onderdeel niet terugzendt, kan Hewlett Packard Enterprise u voor het vervangende onderdeel kosten in rekening brengen. Bij reparatie door de klant betaalt Hewlett Packard Enterprise alle verzendkosten voor het vervangende en geretourneerde onderdeel en kiest Hewlett Packard Enterprise zelf welke koerier/transportonderneming hiervoor wordt gebruikt.

Neem contact op met een Service Partner voor meer informatie over het Customer Self Repair programma van Hewlett Packard Enterprise. Informatie over Service Partners vindt u op de Hewlett Packard Enterprise website (<http://www.hpe.com/support/selfrepair>).

Reparo feito pelo cliente

Os produtos da Hewlett Packard Enterprise são projetados com muitas peças para reparo feito pelo cliente (CSR) de modo a minimizar o tempo de reparo e permitir maior flexibilidade na substituição de peças com defeito. Se, durante o período de diagnóstico, a Hewlett Packard Enterprise (ou fornecedores/parceiros da Hewlett Packard Enterprise) concluir que o reparo pode ser efetuado pelo uso de uma peça CSR, a Hewlett Packard Enterprise enviará a peça diretamente ao cliente. Há duas categorias de peças CSR:

- **Obrigatória**—Peças cujo reparo feito pelo cliente é obrigatório. Se desejar que a Hewlett Packard Enterprise substitua essas peças, serão cobradas as despesas de transporte e mão-de-obra do serviço.
- **Opcional**—Peças cujo reparo feito pelo cliente é opcional. Essas peças também são projetadas para o reparo feito pelo cliente. No entanto, se desejar que a Hewlett Packard Enterprise as substitua, pode haver ou não a cobrança de taxa adicional, dependendo do tipo de serviço de garantia destinado ao produto.

OBSERVAÇÃO: Algumas peças da Hewlett Packard Enterprise não são projetadas para o reparo feito pelo cliente. A fim de cumprir a garantia do cliente, a Hewlett Packard Enterprise exige que um técnico autorizado substitua a peça. Essas peças estão identificadas com a marca "No" (Não), no catálogo de peças ilustrado.

Conforme a disponibilidade e o local geográfico, as peças CSR serão enviadas no primeiro dia útil após o pedido. Onde as condições geográficas permitirem, a entrega no mesmo dia ou em quatro horas pode ser feita mediante uma taxa adicional. Se precisar de auxílio, entre em contato com o Centro de suporte técnico da Hewlett Packard Enterprise para que um técnico o ajude por telefone. A Hewlett Packard Enterprise especifica nos materiais fornecidos com a peça CSR de reposição se a peça com defeito deve ser devolvida à Hewlett Packard Enterprise. Nos casos em que isso for necessário, é preciso enviar a peça com defeito à Hewlett Packard Enterprise, você deverá enviar a peça com defeito de volta para a Hewlett Packard Enterprise dentro do período de tempo definido, normalmente em 5 (cinco) dias úteis. A peça com defeito deve ser enviada com a documentação correspondente no material de transporte fornecido. Caso não o faça, a Hewlett Packard Enterprise poderá cobrar a reposição. Para as peças de reparo feito pelo cliente, a Hewlett Packard Enterprise paga todas as despesas de transporte e de devolução da peça e determina a transportadora/serviço postal a ser utilizado.

Para obter mais informações sobre o programa de reparo feito pelo cliente da Hewlett Packard Enterprise, entre em contato com o fornecedor de serviços local. Para o programa norte-americano, visite o site da Hewlett Packard Enterprise (<http://www.hpe.com/support/selfrepair>).

カスタマーセルフリペア

修理時間を短縮し、故障部品の交換における高い柔軟性を確保するために、Hewlett Packard Enterprise製品には多数のカスタマーセルフリペア（CSR）部品があります。診断の際に、CSR部品を使用すれば修理ができるとHewlett Packard Enterprise（Hewlett Packard EnterpriseまたはHewlett Packard Enterprise正規保守代理店）が判断した場合、Hewlett Packard Enterpriseはその部品を直接、お客様に発送し、お客様に交換していただきます。CSR部品には以下の2種類があります。

- **必須** - カスタマーセルフリペアが必須の部品。当該部品について、もしもお客様がHewlett Packard Enterpriseに交換作業を依頼される場合には、その修理サービスに関する交通費および人件費がお客様に請求されます。
- **任意** - カスタマーセルフリペアが任意である部品。この部品もカスタマーセルフリペア用です。当該部品について、もしもお客様がHewlett Packard Enterpriseに交換作業を依頼される場合には、お買い上げの製品に適用される保証サービス内容の範囲内においては、別途費用を負担していただくことなく保証サービスを受けることができます。

注： Hewlett Packard Enterprise製品の一部の部品は、カスタマーセルフリペアの対象外です。製品の保証を継続するためには、Hewlett Packard EnterpriseまたはHewlett Packard Enterprise正規保守代理店による交換作業が必須となります。部品カタログには、当該部品がカスタマーセルフリペア除外品である旨が記載されています。

部品供給が可能な場合、地域によっては、CSR部品を翌営業日に届くように発送します。また、地域によっては、追加費用を負担いただくことにより同日または4時間以内に届くように発送することも可能な場合があります。サポートが必要なときは、Hewlett Packard Enterpriseの修理受付窓口に電話していただければ、技術者が電話でアドバイスします。交換用のCSR部品または同梱物には、故障部品をHewlett Packard Enterpriseに返送する必要があるかどうかが表示されています。故障部品をHewlett Packard Enterpriseに返送する必要がある場合は、指定期限内（通常は5営業日以内）に故障部品をHewlett Packard Enterpriseに返送してください。故障部品を返送する場合は、届いた時の梱包箱に関連書類とともに入れてください。故障部品を返送しない場合、Hewlett Packard Enterpriseから部品費用が請求されます。カスタマーセルフリペアの際には、Hewlett Packard Enterpriseは送料および部品返送費を全額負担し、使用する宅配便会社や運送会社を指定します。

客户自行维修

Hewlett Packard Enterprise 产品提供许多客户自行维修 (CSR) 部件，以尽可能缩短维修时间和在更换缺陷部件方面提供更大的灵活性。如果在诊断期间 Hewlett Packard Enterprise (或 Hewlett Packard Enterprise 服务提供商或服务合作伙伴) 确定可以通过使用 CSR 部件完成维修，Hewlett Packard Enterprise 将直接把该部件发送给您进行更换。有两类 CSR 部件：

- **强制性的** — 要求客户必须自行维修的部件。如果您请求 Hewlett Packard Enterprise 更换这些部件，则必须为该服务支付差旅费和人工费用。
- **可选的** — 客户可以选择是否自行维修的部件。这些部件也是为客户自行维修设计的。不过，如果您要求 Hewlett Packard Enterprise 为您更换这些部件，则根据为您的产品指定的保修服务类型，Hewlett Packard Enterprise 可能收取或不再收取任何附加费用。

注：某些 Hewlett Packard Enterprise 部件的设计并未考虑客户自行维修。为了满足客户保修的需要，Hewlett Packard Enterprise 要求授权服务提供商更换相关部件。这些部件在部件图解目录中标记为“否”。

CSR 部件将在下一个工作日发运（取决于备货情况和允许的地理范围）。在允许的地理范围内，可在当天或四小时内发运，但要收取额外费用。如果需要帮助，您可以致电 Hewlett Packard Enterprise 技术支持中心，将会有技术人员通过电话为您提供帮助。Hewlett Packard Enterprise 会在随更换的 CSR 部件发运的材料中指明是否必须将有缺陷的部件返还给 Hewlett Packard Enterprise。如果要求您将有缺陷的部件返还给 Hewlett Packard Enterprise，那么您必须在规定的期限内（通常是五 (5) 个工作日）将缺陷部件发给 Hewlett Packard Enterprise。有缺陷的部件必须随所提供的发运材料中的相关文件一起返还。如果未能送还有缺陷的部件，Hewlett Packard Enterprise 可能会要求您支付更换费用。客户自行维修时，Hewlett Packard Enterprise 将承担所有相关运输和部件返回费用，并指定快递商/承运商。

有关 Hewlett Packard Enterprise 客户自行维修计划的详细信息，请与您当地的服务提供商联系。有关北美地区的计划，请访问 Hewlett Packard Enterprise 网站 (<http://www.hpe.com/support/selfrepair>)。

客戶自行維修

Hewlett Packard Enterprise 產品設計了許多「客戶自行維修」(CSR) 的零件以減少維修時間，並且使得更換瑕疵零件時能有更大的彈性。如果在診斷期間，Hewlett Packard Enterprise (或 Hewlett Packard Enterprise 服務供應商或維修夥伴) 辨認出此項維修工作可以藉由使用 CSR 零件來完成，則 Hewlett Packard Enterprise 將直接寄送該零件給您作更換。CSR 零件分為兩種類別：

- **強制的** — 客戶自行維修所使用的零件是強制性的。如果您要求 Hewlett Packard Enterprise 更換這些零件，Hewlett Packard Enterprise 將會向您收取此服務所需的外出費用與勞動成本。
- **選購的** — 客戶自行維修所使用的零件是選購的。這些零件也設計用於客戶自行維修之用。不過，如果您要求 Hewlett Packard Enterprise 為您更換，則可能需要也可能不需要負擔額外的費用，端視針對此產品指定的保固服務類型而定。

備註：某些 Hewlett Packard Enterprise 零件沒有消費者可自行維修的設計。為符合客戶保固，Hewlett Packard Enterprise 需要授權的服務供應商更換零件。這些零件在圖示的零件目錄中，被標示為「否」。

基於材料取得及環境允許的情況下，CSR 零件將於下一個工作日以快遞寄送。在環境的允許下當天或四小時內送達，則可能需要額外的費用。若您需要協助，可致電 Hewlett Packard Enterprise 支援中心，會有一位技術人員透過電話來協助您。不論損壞的零件是否必須退回，Hewlett Packard Enterprise 皆會在與 CSR 替換零件一起運送的材料中註明。若要將損壞的零件退回 Hewlett Packard Enterprise，您必須在指定的一段時間內（通常為五 (5) 個工作天），將損壞的零件寄回 Hewlett Packard Enterprise。損壞的零件必須與寄送資料中隨附的相關技術文件一併退還。如果無法退還損壞的零件，Hewlett Packard Enterprise 可能要向您收取替換費用。針對客戶自行維修情形，Hewlett Packard Enterprise 將負責所有運費及零件退還費用，並指定使用何家快遞/貨運公司。

如需 Hewlett Packard Enterprise 的 CSR 方案詳細資訊，請連絡您當地的服務供應商。至於北美方案，請參閱 Hewlett Packard Enterprise 的 CSR 網站 [selfrepair](http://www.hpe.com/support/selfrepair) (<http://www.hpe.com/support/selfrepair>)。

고객 셀프 수리

Hewlett Packard Enterprise 제품은 수리 시간을 최소화하고 결함이 있는 부품 교체 시 더욱 용통성을 발휘할 수 있도록 하기 위해 고객 셀프 수리(CSR) 부품을 다량 사용하여 설계되었습니다. 진단 기간 동안 Hewlett Packard Enterprise(또는 Hewlett Packard Enterprise 서비스 공급업체 또는 서비스 협력업체)에서 CSR 부품을 사용하여 수리가 가능하다고 판단되면 Hewlett Packard Enterprise는 해당 부품을 바로 사용자에게 보내어 사용자가 교체할 수 있도록 합니다. CSR 부품에는 두 가지 종류가 있습니다.

- 필수 - 고객 셀프 수리가 의무 사항인 필수 부품. 사용자가 Hewlett Packard Enterprise에 이 부품의 교체를 요청할 경우 이 서비스에 대한 출장비 및 작업비가 청구됩니다.
- 선택 사항 - 고객 셀프 수리가 선택 사항인 부품. 이 부품들도 고객 셀프 수리가 가능하도록 설계되었습니다. 하지만 사용자가 Hewlett Packard Enterprise에 이 부품의 교체를 요청할 경우 사용자가 구입한 제품에 해당하는 보증 서비스 유형에 따라 추가 비용 없이 교체가 가능할 수 있습니다.

참고: 일부 Hewlett Packard Enterprise 부품은 고객 셀프 수리가 불가능하도록 설계되었습니다. Hewlett Packard Enterprise는 만족스러운 고객 보증을 위해 공인 서비스 제공업체를 통해 부품을 교체하도록 하고 있습니다. 이러한 부품들은 Illustrated Parts Catalog에 “No”라고 표시되어 있습니다.

CSR 부품은 재고 상태와 지리적 조건이 허용하는 경우 다음 영업일 납품이 가능하도록 배송이 이루어집니다. 지리적 조건이 허용하는 경우 추가 비용이 청구되는 조건으로 당일 또는 4시간 배송이 가능할 수도 있습니다. 도움이 필요하시면 Hewlett Packard Enterprise Support Center로 전화하십시오. 전문 기술자가 전화로 도움을 줄 것입니다. Hewlett Packard Enterprise는 결함이 발생한 부품을 Hewlett Packard Enterprise로 반환해야 하는지 여부를 CSR 교체 부품과 함께 배송된 자료에 지정합니다. 결함이 발생한 부품을 Hewlett Packard Enterprise로 반환해야 하는 경우에는 지정된 기간 내(통상 영업일 기준 5일)에 Hewlett Packard Enterprise로 반환해야 합니다. 이때 결함이 발생한 부품은 제공된 포장 재료에 넣어 관련 설명서와 함께 반환해야 합니다. 결함이 발생한 부품을 반환하지 않는 경우 Hewlett Packard Enterprise가 교체 부품에 대해 비용을 청구할 수 있습니다. 고객 셀프 수리의 경우, Hewlett Packard Enterprise는 모든 운송 및 부품 반환 비용을 부담하며 이용할 운송업체 및 택배 서비스를 결정합니다.

Hewlett Packard Enterprise CSR 프로그램에 대한 자세한 내용은 가까운 서비스 제공업체에 문의하십시오. 북미 지역의 프로그램에 대해서는 Hewlett Packard Enterprise CSR 웹 사이트(<http://www.hpe.com/support/selfrepair>)를 참조하십시오.

Remote support

Remote support is available with supported devices as part of your warranty or contractual support agreement. It provides intelligent event diagnosis, and automatic, secure submission of hardware event notifications to Hewlett Packard Enterprise, which will initiate a fast and accurate resolution based on your product's service level. Hewlett Packard Enterprise strongly recommends that you register your device for remote support.

For more information and device support details, go to the Insight Remote Support website (<http://www.hpe.com/info/insightremotesupport/docs>).

Acronyms and abbreviations

ABEND

abnormal end

ACU

Array Configuration Utility

ADM

Advanced Data Mirroring

AMP

Advanced Memory Protection

ASR

Automatic Server Recovery

BAR

base address register

CSA

Canadian Standards Association

CSR

Customer Self Repair

DDDC

Double Device Data Correction

DDR

double data rate

FBWC

flash-backed write cache

GPU

graphics processing unit

HP SUM

HP Smart Update Manager

HPE SSA

HPE Smart Storage Administrator

IEC

International Electrotechnical Commission

iLO

Integrated Lights-Out

IML

Integrated Management Log

LRDIMM

load reduced dual in-line memory module

NMI

nonmaskable interrupt

NVRAM

nonvolatile memory

ORCA

Option ROM Configuration for Arrays

PCIe

Peripheral Component Interconnect Express

POST

Power-On Self Test

RBSU

ROM-Based Setup Utility

RDIMM

registered dual in-line memory module

RDP

Rapid Deployment Pack

RPS

redundant power supply

SAS

serial attached SCSI

SATA

serial ATA

SDDC

Single Device Data Correction

SFF

small form factor

SIM

Systems Insight Manager

SLAPM

SL Advanced Power Manager

SPP

Service Pack for ProLiant

SUV

serial, USB, video

TMRA

recommended ambient operating temperature

TPM

Trusted Platform Module

UDIMM

unregistered dual in-line memory module

UID

unit identification

USB

universal serial bus

VCA

Version Control Agent

VCRM

Version Control Repository Manager

Documentation feedback

Hewlett Packard Enterprise is committed to providing documentation that meets your needs. To help us improve the documentation, send any errors, suggestions, or comments to Documentation Feedback (<mailto:docsfeedback@hpe.com>). When submitting your feedback, include the document title, part number, edition, and publication date located on the front cover of the document. For online help content, include the product name, product version, help edition, and publication date located on the legal notices page.

Index

A

ACU (Array Configuration Utility) 77, 84
Advanced ECC memory 60, 61, 83
Advanced ECC support 60
airflow requirements 27, 28
AMP modes 59, 83
Array Configuration Utility (ACU) 84
ASR (Automatic Server Recovery) 85
authorized reseller 91, 93
auto-configuration process 82
Automatic Server Recovery (ASR) 85

B

BIOS upgrade 77, 84
boot options 83
buttons, front panel 6
buttons, rear panel 8

C

cables 71
cabling 33, 71, 72, 73, 75
Care Pack 27, 80, 87
cautions 91
Change Control 84, 87
chassis components 29
chassis, removing server 14
clearing NVRAM 11
components 6
components, identification 6, 10
components, rear panel 8
components, system board 9
configuration of system 77
connectors 6
contacting Hewlett Packard Enterprise 93
coprocessor 44, 46
crash dump analysis 11

D

Declaration of Conformity 90
default settings 60
diagnosing problems 88
diagnostic tools 79, 84, 85
diagnostics utility 79
DIMM installation guidelines 62
DIMM slot locations 10
DIMMs 10, 58, 62
DIMMs, dual-rank 58

DIMMs, quad-rank 58
DIMMs, single- and dual-rank 58
drive cage, installing 16
drive cage, removing 15
drive guidelines 34
drive LEDs 13
drive numbering 12
drivers 86
drives 13, 34
drives, determining status of 13
drives, installing 34

E

electrical grounding requirements 28
electrostatic discharge 91
environmental requirements 27
Erase Utility 77, 80
expansion board 39

F

fan LED 8
fan module location 8
fans 8
FBWC capacitor pack 36, 73
features 6, 84
FlexibleLOM riser cage 25
front panel buttons 7
front panel components 6

G

general diagnosis flowchart 7
GPU enablement 12, 44, 46, 50
GPU module, removing 50
GPU numbering 12
grounding methods 91
grounding requirements 28, 91

H

hard drive LEDs 13
hard drives, determining status of 13
hardware options 33
hardware options installation 33
health driver 85
health LEDs 6
Hewlett Packard Enterprise website 93
hot-plug drive 34
HP Care Pack Services 27, 87
HP Trusted Platform Module option 65, 66, 70

HPE Insight Diagnostics 79
HPE SmartMemory 57

I

iLO (Integrated Lights-Out) 77, 78, 79
IML (Integrated Management Log) 77, 79
Insight Diagnostics 79, 86
installation services 27
installation, chassis 30
installation, server options 33
installing hardware 33
installing server options 33
Integrated Lights-Out (iLO) 77, 79
Integrated Management Log (IML) 79

L

LEDs 8, 13
LEDs, drive 13
LEDs, fan 8
LEDs, front panel 7, 13
LEDs, hard drive 13
LEDs, power supply 8
LEDs, SAS hard drive 13
LEDs, troubleshooting 88
LEDs, unit identification (UID) 8
lockstep memory 60, 61

M

memory 10, 57, 58, 60
memory configurations 60
memory options 57
Memory Protection option 59
memory subsystem architecture 58
memory, Advanced ECC 60, 83
memory, configuration requirements 60, 61
memory, configuring 60
memory, lockstep 61, 62
memory, online spare 60, 83
Mini-SAS cable 41

N

NMI header 9, 11

O

online spare memory 60, 61, 83
online spare population guidelines 60, 61
operating systems 87
operations 14
optimum environment 27
Option ROM Configuration for Arrays (ORCA) 77, 84
options installation 27, 33
ORCA (Option ROM Configuration for Arrays) 77, 84

P

PCI riser cage 24, 25
PDU (power distribution unit) 28
phone numbers 93
population guidelines 34, 61
population guidelines, Advanced ECC 61
population guidelines, Lockstep memory 61
population order, memory 61, 62
POST error messages 35, 88
power distribution unit (PDU) 28
Power On button 14
power supply 92
power supply LEDs 8
powering down 14
powering up 14, 31
preparation procedures 14
problem diagnosis 88
processor air baffle 23
processor option 53
PXE (preboot execution environment) 81, 83
PXE boot, illustration 83

R

rack installation 27, 29
rack warnings 29
Rapid Deployment Pack (RDP) 27
RBSU (ROM-Based Setup Utility) 77, 81, 82, 83
RBSU configuration 82
RDP (Rapid Deployment Pack) 27
rear components 8
rear panel components 8
rear panel connectors 8
rear panel LEDs 8
recommended ambient operating temperature (TMRA) 28
redundant ROM 85
registering the server 32
regulatory compliance notices 90
removing PCI riser cage 24
removing server from chassis 14
requirements, airflow 27
requirements, electrical grounding 28
requirements, space 27
requirements, temperature 28
ROM redundancy 85
ROM-Based Setup Utility (RBSU) 65, 81
ROMPaq utility 77, 84, 85

S

safety considerations 29, 85, 90, 91
safety information 85, 90
SAS drives 13
scripted installation 81
serial number 83
series number 90
server features and options 33

- server, installation 14
- shipping bracket, installing 16, 18
- shipping carton contents 29
- software 31, 86, 87
- space requirements 27
- specifications 92
- static electricity 91
- support 93
- supported operating systems 87
- SUV cable 33
- system battery 89
- system board components 9
- system configuration settings 11, 85
- System Erase Utility 80
- system maintenance switch 11

T

- technical support 87, 93
- telephone numbers 93
- temperature requirements 28
- TMRA (recommended ambient operating temperature) 28
- TPM connector 9
- troubleshooting 88
- Trusted Platform Module (TPM) 65, 69, 70

U

- UID LED 8
- updating the system ROM 85
- USB support 85
- utilities 77, 84
- utilities, deployment 77, 81

V

- ventilation 27

W

- warnings 29
- website, Hewlett Packard Enterprise 93