

# HP ProLiant SL270s Gen8 Server Maintenance and Service Guide

## Abstract

This guide is for an experienced service technician. HP assumes you are qualified in the servicing of computer equipment and trained in recognizing hazards in products with hazardous energy levels and are familiar with weight and stability precautions for rack installations.



Part Number: 666299-001  
August 2012  
Edition: 1

© Copyright 2012 Hewlett-Packard Development Company, L.P.

The information contained herein is subject to change without notice. The only warranties for HP products and services are set forth in the express warranty statements accompanying such products and services. Nothing herein should be construed as constituting an additional warranty. HP shall not be liable for technical or editorial errors or omissions contained herein.

Microsoft® and Windows® are U.S. registered trademarks of Microsoft Corporation. Intel® Xeon® is a trademark of Intel Corporation in the U.S. and other countries.

---

# Contents

Customer self repair .....	5
Parts only warranty service .....	5
Illustrated parts catalog .....	16
Mechanical components.....	16
System components .....	19
Removal and replacement procedures .....	25
Required tools.....	25
Safety considerations.....	25
Preventing electrostatic discharge .....	25
Symbols on equipment .....	25
Server warnings and cautions .....	26
Preparation procedures.....	26
Power down the server.....	27
Remove the server from the chassis .....	27
Drive blank.....	28
Hot-plug drive .....	28
Hot-plug drive cage.....	29
Expansion boards .....	30
PCI riser board assembly.....	31
x16/x32 riser board assembly .....	32
GPU module.....	34
GPU shelf.....	35
Mezzanine board .....	37
FBWC capacitor pack .....	38
FBWC capacitor pack holder.....	39
Processor air baffle.....	40
DIMMs.....	41
Heatsink.....	42
Processor .....	45
System battery .....	49
System board .....	50
Power module.....	53
Personality board .....	54
Power interface board and bus bar .....	55
HP Trusted Platform Module .....	56
Diagnostic tools .....	57
Troubleshooting resources .....	57
HP ROM-Based Setup Utility .....	57
HP Insight Diagnostics.....	58
Integrated Management Log .....	58
Component identification.....	59
Front panel components .....	59
Front panel LEDs and buttons .....	60
Rear panel components.....	61

Rear panel LEDs and buttons.....	61
System board components.....	62
DIMM slot locations.....	63
System maintenance switch.....	64
NMI header.....	64
Device numbers.....	65
Drive LED definitions.....	65
<b>Cabling.....</b>	<b>67</b>
Cabling overview.....	67
FBWC capacitor pack cabling.....	67
<b>Specifications.....</b>	<b>69</b>
Environmental specifications.....	69
Server specifications.....	69
Hot-plug power supply calculations.....	69
<b>Acronyms and abbreviations.....</b>	<b>70</b>
<b>Documentation feedback.....</b>	<b>72</b>
<b>Index.....</b>	<b>73</b>

---

# Customer self repair

HP products are designed with many Customer Self Repair (CSR) parts to minimize repair time and allow for greater flexibility in performing defective parts replacement. If during the diagnosis period HP (or HP service providers or service partners) identifies that the repair can be accomplished by the use of a CSR part, HP will ship that part directly to you for replacement. There are two categories of CSR parts:

- **Mandatory**—Parts for which customer self repair is mandatory. If you request HP to replace these parts, you will be charged for the travel and labor costs of this service.
- **Optional**—Parts for which customer self repair is optional. These parts are also designed for customer self repair. If, however, you require that HP replace them for you, there may or may not be additional charges, depending on the type of warranty service designated for your product.

**NOTE:** Some HP parts are not designed for customer self repair. In order to satisfy the customer warranty, HP requires that an authorized service provider replace the part. These parts are identified as "No" in the Illustrated Parts Catalog.

Based on availability and where geography permits, CSR parts will be shipped for next business day delivery. Same day or four-hour delivery may be offered at an additional charge where geography permits. If assistance is required, you can call the HP Technical Support Center and a technician will help you over the telephone. HP specifies in the materials shipped with a replacement CSR part whether a defective part must be returned to HP. In cases where it is required to return the defective part to HP, you must ship the defective part back to HP within a defined period of time, normally five (5) business days. The defective part must be returned with the associated documentation in the provided shipping material. Failure to return the defective part may result in HP billing you for the replacement. With a customer self repair, HP will pay all shipping and part return costs and determine the courier/carrier to be used.

For more information about HP's Customer Self Repair program, contact your local service provider. For the North American program, refer to the HP website (<http://www.hp.com/go/selfrepair>).

## Parts only warranty service

Your HP Limited Warranty may include a parts only warranty service. Under the terms of parts only warranty service, HP will provide replacement parts free of charge.

For parts only warranty service, CSR part replacement is mandatory. If you request HP to replace these parts, you will be charged for the travel and labor costs of this service.

## Réparation par le client (CSR)

Les produits HP comportent de nombreuses pièces CSR (Customer Self Repair = réparation par le client) afin de minimiser les délais de réparation et faciliter le remplacement des pièces défectueuses. Si pendant la période de diagnostic, HP (ou ses partenaires ou mainteneurs agréés) détermine que la réparation peut être effectuée à l'aide d'une pièce CSR, HP vous l'envoie directement. Il existe deux catégories de pièces CSR:

Obligatoire - Pièces pour lesquelles la réparation par le client est obligatoire. Si vous demandez à HP de remplacer ces pièces, les coûts de déplacement et main d'œuvre du service vous seront facturés.

Facultatif - Pièces pour lesquelles la réparation par le client est facultative. Ces pièces sont également conçues pour permettre au client d'effectuer lui-même la réparation. Toutefois, si vous demandez à HP de remplacer ces pièces, l'intervention peut ou non vous être facturée, selon le type de garantie applicable à votre produit.

**REMARQUE:** Certaines pièces HP ne sont pas conçues pour permettre au client d'effectuer lui-même la réparation. Pour que la garantie puisse s'appliquer, HP exige que le remplacement de la pièce soit effectué par un Mainteneur Agréé. Ces pièces sont identifiées par la mention "Non" dans le Catalogue illustré.

Les pièces CSR sont livrées le jour ouvré suivant, dans la limite des stocks disponibles et selon votre situation géographique. Si votre situation géographique le permet et que vous demandez une livraison le jour même ou dans les 4 heures, celle-ci vous sera facturée. Pour bénéficier d'une assistance téléphonique, appelez le Centre d'assistance technique HP. Dans les documents envoyés avec la pièce de rechange CSR, HP précise s'il est nécessaire de lui retourner la pièce défectueuse. Si c'est le cas, vous devez le faire dans le délai indiqué, généralement cinq (5) jours ouvrés. La pièce et sa documentation doivent être retournées dans l'emballage fourni. Si vous ne retournez pas la pièce défectueuse, HP se réserve le droit de vous facturer les coûts de remplacement. Dans le cas d'une pièce CSR, HP supporte l'ensemble des frais d'expédition et de retour, et détermine la société de courses ou le transporteur à utiliser.

Pour plus d'informations sur le programme CSR de HP, contactez votre Mainteneur Agréé local. Pour plus d'informations sur ce programme en Amérique du Nord, consultez le site Web HP (<http://www.hp.com/go/selfrepair>).

## Service de garantie "pièces seules"

Votre garantie limitée HP peut inclure un service de garantie "pièces seules". Dans ce cas, les pièces de rechange fournies par HP ne sont pas facturées.

Dans le cadre de ce service, la réparation des pièces CSR par le client est obligatoire. Si vous demandez à HP de remplacer ces pièces, les coûts de déplacement et main d'œuvre du service vous seront facturés.

## Riparazione da parte del cliente

Per abbreviare i tempi di riparazione e garantire una maggiore flessibilità nella sostituzione di parti difettose, i prodotti HP sono realizzati con numerosi componenti che possono essere riparati direttamente dal cliente (CSR, Customer Self Repair). Se in fase di diagnostica HP (o un centro di servizi o di assistenza HP) identifica il guasto come riparabile mediante un ricambio CSR, HP lo spedisce direttamente al cliente per la sostituzione. Vi sono due categorie di parti CSR:

**Obbligatorie** – Parti che devono essere necessariamente riparate dal cliente. Se il cliente ne affida la riparazione ad HP, deve sostenere le spese di spedizione e di manodopera per il servizio.

**Opzionali** – Parti la cui riparazione da parte del cliente è facoltativa. Si tratta comunque di componenti progettati per questo scopo. Se tuttavia il cliente ne richiede la sostituzione ad HP, potrebbe dover sostenere spese aggiuntive a seconda del tipo di garanzia previsto per il prodotto.

**NOTA:** alcuni componenti HP non sono progettati per la riparazione da parte del cliente. Per rispettare la garanzia, HP richiede che queste parti siano sostituite da un centro di assistenza autorizzato. Tali parti sono identificate da un "No" nel Catalogo illustrato dei componenti.

In base alla disponibilità e alla località geografica, le parti CSR vengono spedite con consegna entro il giorno lavorativo seguente. La consegna nel giorno stesso o entro quattro ore è offerta con un supplemento di costo solo in alcune zone. In caso di necessità si può richiedere l'assistenza telefonica di un addetto del centro di supporto tecnico HP. Nel materiale fornito con una parte di ricambio CSR, HP specifica se il cliente deve restituire dei componenti. Qualora sia richiesta la resa ad HP del componente difettoso, lo si deve spedire ad HP entro un determinato periodo di tempo, generalmente cinque (5) giorni lavorativi. Il componente difettoso deve essere restituito con la documentazione associata nell'imballo di spedizione fornito. La mancata restituzione del componente può comportare la fatturazione del ricambio da parte di HP. Nel caso di riparazione da parte del cliente, HP sostiene tutte le spese di spedizione e resa e sceglie il corriere/vettore da utilizzare.

Per ulteriori informazioni sul programma CSR di HP contattare il centro di assistenza di zona. Per il programma in Nord America fare riferimento al sito Web HP (<http://www.hp.com/go/selfrepair>).

## Servizio di garanzia per i soli componenti

La garanzia limitata HP può includere un servizio di garanzia per i soli componenti. Nei termini di garanzia del servizio per i soli componenti, HP fornirà gratuitamente le parti di ricambio.

Per il servizio di garanzia per i soli componenti è obbligatoria la formula CSR che prevede la riparazione da parte del cliente. Se il cliente invece richiede la sostituzione ad HP, dovrà sostenere le spese di spedizione e di manodopera per il servizio.

## Customer Self Repair

HP Produkte enthalten viele CSR-Teile (Customer Self Repair), um Reparaturzeiten zu minimieren und höhere Flexibilität beim Austausch defekter Bauteile zu ermöglichen. Wenn HP (oder ein HP Servicepartner) bei der Diagnose feststellt, dass das Produkt mithilfe eines CSR-Teils repariert werden kann, sendet Ihnen HP dieses Bauteil zum Austausch direkt zu. CSR-Teile werden in zwei Kategorien unterteilt:

**Zwingend** – Teile, für die das Customer Self Repair-Verfahren zwingend vorgegeben ist. Wenn Sie den Austausch dieser Teile von HP vornehmen lassen, werden Ihnen die Anfahrt- und Arbeitskosten für diesen Service berechnet.

**Optional** – Teile, für die das Customer Self Repair-Verfahren optional ist. Diese Teile sind auch für Customer Self Repair ausgelegt. Wenn Sie jedoch den Austausch dieser Teile von HP vornehmen lassen möchten, können bei diesem Service je nach den für Ihr Produkt vorgesehenen Garantiebedingungen zusätzliche Kosten anfallen.

**HINWEIS:** Einige Teile sind nicht für Customer Self Repair ausgelegt. Um den Garantieanspruch des Kunden zu erfüllen, muss das Teil von einem HP Servicepartner ersetzt werden. Im illustrierten Teilekatalog sind diese Teile mit „No“ bzw. „Nein“ gekennzeichnet.

CSR-Teile werden abhängig von der Verfügbarkeit und vom Lieferziel am folgenden Geschäftstag geliefert. Für bestimmte Standorte ist eine Lieferung am selben Tag oder innerhalb von vier Stunden gegen einen Aufpreis verfügbar. Wenn Sie Hilfe benötigen, können Sie das HP technische Support Center anrufen und sich von einem Mitarbeiter per Telefon helfen lassen. Den Materialien, die mit einem CSR-Ersatzteil geliefert werden, können Sie entnehmen, ob das defekte Teil an HP zurückgeschickt werden muss. Wenn es erforderlich ist, das defekte Teil an HP zurückzuschicken, müssen Sie dies innerhalb eines vorgegebenen Zeitraums tun, in der Regel innerhalb von fünf (5) Geschäftstagen. Das defekte Teil muss mit der zugehörigen Dokumentation in der Verpackung zurückgeschickt werden, die im Lieferumfang enthalten ist. Wenn Sie das

defekte Teil nicht zurückschicken, kann HP Ihnen das Ersatzteil in Rechnung stellen. Im Falle von Customer Self Repair kommt HP für alle Kosten für die Lieferung und Rücksendung auf und bestimmt den Kurier-/Frachtdienst.

Weitere Informationen über das HP Customer Self Repair Programm erhalten Sie von Ihrem Servicepartner vor Ort. Informationen über das CSR-Programm in Nordamerika finden Sie auf der HP Website unter (<http://www.hp.com/go/selfrepair>).

## Parts-only Warranty Service (Garantieservice ausschließlich für Teile)

Ihre HP Garantie umfasst möglicherweise einen Parts-only Warranty Service (Garantieservice ausschließlich für Teile). Gemäß den Bestimmungen des Parts-only Warranty Service stellt HP Ersatzteile kostenlos zur Verfügung.

Für den Parts-only Warranty Service ist das CSR-Verfahren zwingend vorgegeben. Wenn Sie den Austausch dieser Teile von HP vornehmen lassen, werden Ihnen die Anfahrt- und Arbeitskosten für diesen Service berechnet.

## Reparaciones del propio cliente

Los productos de HP incluyen muchos componentes que el propio usuario puede reemplazar (*Customer Self Repair*, CSR) para minimizar el tiempo de reparación y ofrecer una mayor flexibilidad a la hora de realizar sustituciones de componentes defectuosos. Si, durante la fase de diagnóstico, HP (o los proveedores o socios de servicio de HP) identifica que una reparación puede llevarse a cabo mediante el uso de un componente CSR, HP le enviará dicho componente directamente para que realice su sustitución. Los componentes CSR se clasifican en dos categorías:

- **Obligatorio:** componentes para los que la reparación por parte del usuario es obligatoria. Si solicita a HP que realice la sustitución de estos componentes, tendrá que hacerse cargo de los gastos de desplazamiento y de mano de obra de dicho servicio.
- **Opcional:** componentes para los que la reparación por parte del usuario es opcional. Estos componentes también están diseñados para que puedan ser reparados por el usuario. Sin embargo, si precisa que HP realice su sustitución, puede o no conllevar costes adicionales, dependiendo del tipo de servicio de garantía correspondiente al producto.

**NOTA:** Algunos componentes no están diseñados para que puedan ser reparados por el usuario. Para que el usuario haga valer su garantía, HP pone como condición que un proveedor de servicios autorizado realice la sustitución de estos componentes. Dichos componentes se identifican con la palabra "No" en el catálogo ilustrado de componentes.

Según la disponibilidad y la situación geográfica, los componentes CSR se enviarán para que lleguen a su destino al siguiente día laborable. Si la situación geográfica lo permite, se puede solicitar la entrega en el mismo día o en cuatro horas con un coste adicional. Si precisa asistencia técnica, puede llamar al Centro de asistencia técnica de HP y recibirá ayuda telefónica por parte de un técnico. Con el envío de materiales para la sustitución de componentes CSR, HP especificará si los componentes defectuosos deberán devolverse a HP. En aquellos casos en los que sea necesario devolver algún componente a HP, deberá hacerlo en el periodo de tiempo especificado, normalmente cinco días laborables. Los componentes defectuosos deberán devolverse con toda la documentación relacionada y con el embalaje de envío. Si no



enviara el componente defectuoso requerido, HP podrá cobrarle por el de sustitución. En el caso de todas sustituciones que lleve a cabo el cliente, HP se hará cargo de todos los gastos de envío y devolución de componentes y escogerá la empresa de transporte que se utilice para dicho servicio.

Para obtener más información acerca del programa de Reparaciones del propio cliente de HP, póngase en contacto con su proveedor de servicios local. Si está interesado en el programa para Norteamérica, visite la página web de HP siguiente (<http://www.hp.com/go/selfrepair>).

## Servicio de garantía exclusivo de componentes

La garantía limitada de HP puede que incluya un servicio de garantía exclusivo de componentes. Según las condiciones de este servicio exclusivo de componentes, HP le facilitará los componentes de repuesto sin cargo adicional alguno.

Para este servicio de garantía exclusivo de componentes, es obligatoria la sustitución de componentes por parte del usuario (CSR). Si solicita a HP que realice la sustitución de estos componentes, tendrá que hacerse cargo de los gastos de desplazamiento y de mano de obra de dicho servicio.

## Customer Self Repair

Veel onderdelen in HP producten zijn door de klant zelf te repareren, waardoor de reparatieduur tot een minimum beperkt kan blijven en de flexibiliteit in het vervangen van defecte onderdelen groter is. Deze onderdelen worden CSR-onderdelen (Customer Self Repair) genoemd. Als HP (of een HP Service Partner) bij de diagnose vaststelt dat de reparatie kan worden uitgevoerd met een CSR-onderdeel, verzendt HP dat onderdeel rechtstreeks naar u, zodat u het defecte onderdeel daarmee kunt vervangen. Er zijn twee categorieën CSR-onderdelen:

**Verplicht:** Onderdelen waarvoor reparatie door de klant verplicht is. Als u HP verzoekt deze onderdelen voor u te vervangen, worden u voor deze service reiskosten en arbeidsloon in rekening gebracht.

**Optioneel:** Onderdelen waarvoor reparatie door de klant optioneel is. Ook deze onderdelen zijn ontworpen voor reparatie door de klant. Als u echter HP verzoekt deze onderdelen voor u te vervangen, kunnen daarvoor extra kosten in rekening worden gebracht, afhankelijk van het type garantieservice voor het product.

**OPMERKING:** Sommige HP onderdelen zijn niet ontwikkeld voor reparatie door de klant. In verband met de garantievoorwaarden moet het onderdeel door een geautoriseerde Service Partner worden vervangen. Deze onderdelen worden in de geïllustreerde onderdelencatalogus aangemerkt met "Nee".

Afhankelijk van de leverbaarheid en de locatie worden CSR-onderdelen verzonden voor levering op de eerstvolgende werkdag. Levering op dezelfde dag of binnen vier uur kan tegen meerkosten worden aangeboden, indien dit mogelijk is gezien de locatie. Indien assistentie gewenst is, belt u een HP Service Partner om via de telefoon technische ondersteuning te ontvangen. HP vermeldt in de documentatie bij het vervangende CSR-onderdeel of het defecte onderdeel aan HP moet worden geretourneerd. Als het defecte onderdeel aan HP moet worden teruggezonden, moet u het defecte onderdeel binnen een bepaalde periode, gewoonlijk vijf (5) werkdagen, retourneren aan HP. Het defecte onderdeel moet met de bijbehorende documentatie worden geretourneerd in het meegeleverde verpakkingsmateriaal. Als u het defecte onderdeel niet terugzendt, kan HP u voor het vervangende onderdeel kosten in rekening brengen. Bij reparatie door de klant betaalt HP alle verzendkosten voor het vervangende en geretourneerde onderdeel en kiest HP zelf welke koerier/transportonderneming hiervoor wordt gebruikt.

Neem contact op met een Service Partner voor meer informatie over het Customer Self Repair programma van HP. Informatie over Service Partners vindt u op de HP website (<http://www.hp.com/go/selfrepair>).

## Garantieservice "Parts Only"

Het is mogelijk dat de HP garantie alleen de garantieservice "Parts Only" omvat. Volgens de bepalingen van de Parts Only garantieservice zal HP kosteloos vervangende onderdelen ter beschikking stellen.

Voor de Parts Only garantieservice is vervanging door CSR-onderdelen verplicht. Als u HP verzoekt deze onderdelen voor u te vervangen, worden u voor deze service reiskosten en arbeidsloon in rekening gebracht.

## Reparo feito pelo cliente

Os produtos da HP são projetados com muitas peças para reparo feito pelo cliente (CSR) de modo a minimizar o tempo de reparo e permitir maior flexibilidade na substituição de peças com defeito. Se, durante o período de diagnóstico, a HP (ou fornecedores/parceiros de serviço da HP) concluir que o reparo pode ser efetuado pelo uso de uma peça CSR, a peça de reposição será enviada diretamente ao cliente. Existem duas categorias de peças CSR:

**Obrigatória** – Peças cujo reparo feito pelo cliente é obrigatório. Se desejar que a HP substitua essas peças, serão cobradas as despesas de transporte e mão-de-obra do serviço.

**Opcional** – Peças cujo reparo feito pelo cliente é opcional. Essas peças também são projetadas para o reparo feito pelo cliente. No entanto, se desejar que a HP as substitua, pode haver ou não a cobrança de taxa adicional, dependendo do tipo de serviço de garantia destinado ao produto.

**OBSERVAÇÃO:** Algumas peças da HP não são projetadas para o reparo feito pelo cliente. A fim de cumprir a garantia do cliente, a HP exige que um técnico autorizado substitua a peça. Essas peças estão identificadas com a marca "No" (Não), no catálogo de peças ilustrado.

Conforme a disponibilidade e o local geográfico, as peças CSR serão enviadas no primeiro dia útil após o pedido. Onde as condições geográficas permitirem, a entrega no mesmo dia ou em quatro horas pode ser feita mediante uma taxa adicional. Se precisar de auxílio, entre em contato com o Centro de suporte técnico da HP para que um técnico o ajude por telefone. A HP especifica nos materiais fornecidos com a peça CSR de reposição se a peça com defeito deve ser devolvida à HP. Nos casos em que isso for necessário, é preciso enviar a peça com defeito à HP dentro do período determinado, normalmente cinco (5) dias úteis. A peça com defeito deve ser enviada com a documentação correspondente no material de transporte fornecido. Caso não o faça, a HP poderá cobrar a reposição. Para as peças de reparo feito pelo cliente, a HP paga todas as despesas de transporte e de devolução da peça e determina a transportadora/serviço postal a ser utilizado.

Para obter mais informações sobre o programa de reparo feito pelo cliente da HP, entre em contato com o fornecedor de serviços local. Para o programa norte-americano, visite o site da HP (<http://www.hp.com/go/selfrepair>).

## Serviço de garantia apenas para peças

A garantia limitada da HP pode incluir um serviço de garantia apenas para peças. Segundo os termos do serviço de garantia apenas para peças, a HP fornece as peças de reposição sem cobrar nenhuma taxa.

No caso desse serviço, a substituição de peças CSR é obrigatória. Se desejar que a HP substitua essas peças, serão cobradas as despesas de transporte e mão-de-obra do serviço.

## 顧客自己修理保証サービス

修理時間を短縮し、故障部品の交換における高い柔軟性を確保するために、HP製品には多数の顧客自己修理（CSR）部品があります。診断の際に、CSR部品を使用すれば修理ができるとHP（HPまたはHP正規保守代理店）が判断した場合、HPはその部品を直接、お客様に発送し、お客様に交換していただきます。CSR部品には以下の2通りがあります。

- 必須 - 顧客自己修理が必須の部品。当該部品について、もしもお客様がHPに交換作業を依頼される場合には、その修理サービスに関する交通費および人件費がお客様に請求されます。
- 任意 - 顧客自己修理が任意である部品。この部品も顧客自己修理用です。当該部品について、もしもお客様がHPに交換作業を依頼される場合には、お買い上げの製品に適用される保証サービス内容の範囲内においては、別途費用を負担していただくことなく保証サービスを受けることができます。

注：HP製品の一部の部品は、顧客自己修理用ではありません。製品の保証を継続するためには、HPまたはHP正規保守代理店による交換作業が必須となります。部品カタログには、当該部品が顧客自己修理除外品である旨が記載されています。

部品供給が可能な場合、地域によっては、CSR部品を翌営業日に届くように発送します。また、地域によっては、追加費用を負担いただくことにより同日または4時間以内に届くように発送することも可能な場合があります。サポートが必要なときは、HPの修理受付窓口にご連絡いただければ、技術者が電話でアドバイスします。交換用のCSR部品または同梱物には、故障部品をHPに返送する必要があるかどうかが表示されています。故障部品をHPに返送する必要がある場合は、指定期限内（通常は5営業日以内）に故障部品をHPに返送してください。故障部品を返送する場合は、届いた時の梱包箱に関連書類とともに入れてください。故障部品を返送しない場合、HPから部品費用が請求されます。顧客自己修理の際には、HPは送料および部品返送費を全額負担し、使用する宅配便会社や運送会社を指定します。

## 部品のみ保証サービス

HP保証サービスには、部品のみ保証サービスが適用される場合があります。このサービスでは、交換部品は無償で提供されます。

部品のみ保証サービスにおいては、CSR部品をお客様により交換作業していただくことが必須となります。当該部品について、もしもお客様がHPに交換作業を依頼される場合には、その修理サービスに関する交通費および人件費はお客様の負担となります。

# 客户自行维修

HP 产品提供许多客户自行维修 (CSR) 部件，以尽可能缩短维修时间和在更换缺陷部件方面提供更大的灵活性。如果在诊断期间 HP（或 HP 服务提供商或服务合作伙伴）确定可以通过使用 CSR 部件完成维修，HP 将直接把该部件发送给您进行更换。有两类 CSR 部件：

- **强制性的** — 要求客户必须自行维修的部件。如果您请求 HP 更换这些部件，则必须为该服务支付差旅费和人工费用。
- **可选的** — 客户可以选择是否自行维修的部件。这些部件也是为客户自行维修设计的。不过，如果您要求 HP 为您更换这些部件，则根据为您的产品指定的保修服务类型，HP 可能收取或不再收取任何附加费用。

**注：**某些 HP 部件的设计并未考虑客户自行维修。为了满足客户保修的需要，HP 要求授权服务提供商更换相关部件。这些部件在部件图解目录中标记为“否”。

CSR 部件将在下一个工作日发运（取决于备货情况和允许的地理范围）。在允许的地理范围内，可在当天或四小时内发运，但要收取额外费用。如果需要帮助，您可以致电 HP 技术支持中心，将会有技术人员通过电话为您提供帮助。HP 会在随更换的 CSR 部件发运的材料中指明是否必须将有缺陷的部件返还给 HP。如果要求您将有缺陷的部件返还给 HP，那么您必须在规定期限内（通常是五 (5) 个工作日）将缺陷部件发给 HP。有缺陷的部件必须随所提供的发运材料中的相关文件一起返还。如果未能送还有缺陷的部件，HP 可能会要求您支付更换费用。客户自行维修时，HP 将承担所有相关运输和部件返回费用，并指定快递商/承运商。

有关 HP 客户自行维修计划的详细信息，请与您当地的服务提供商联系。有关北美地区的计划，请访问 HP 网站 (<http://www.hp.com/go/selfrepair>)。

## 仅部件保修服务

您的 HP 有限保修服务可能涉及仅部件保修服务。根据仅部件保修服务条款的规定，HP 将免费提供更换的部件。

仅部件保修服务要求进行 CSR 部件更换。如果您请求 HP 更换这些部件，则必须为该服务支付差旅费和人工费用。

# 客戶自行維修

HP 產品設計了許多「客戶自行維修」(CSR) 的零件以減少維修時間，並且使得更換瑕疵零件時能有更大的彈性。如果在診斷期間 HP (或 HP 服務供應商或維修夥伴) 辨認出此項維修工作可以藉由使用 CSR 零件來完成，則 HP 將直接寄送該零件給您作更換。CSR 零件分為兩種類別：

- **強制的** — 客戶自行維修所使用的零件是強制性的。如果您要求 HP 更換這些零件，HP 將會向您收取此服務所需的外出費用與勞動成本。
- **選購的** — 客戶自行維修所使用的零件是選購的。這些零件也設計用於客戶自行維修之用。不過，如果您要求 HP 為您更換，則可能需要也可能不需要負擔額外的費用，端視針對此產品指定的保固服務類型而定。

**備註：**某些 HP 零件沒有消費者可自行維修的設計。為符合客戶保固，HP 需要授權的服務供應商更換零件。這些零件在圖示的零件目錄中，被標示為「否」。

基於材料取得及環境允許的情況下，CSR 零件將於下一個工作日以快遞寄送。在環境的允許下當天或四小時內送達，則可能需要額外的費用。若您需要協助，可致電「HP 技術支援中心」，會有一位技術人員透過電話來協助您。不論損壞的零件是否必須退回，HP 皆會在與 CSR 替換零件一起運送的材料中註明。若要將損壞的零件退回 HP，您必須在指定的一段時間內（通常為五 (5) 個工作天），將損壞的零件寄回 HP。損壞的零件必須與寄送資料中隨附的相關技術文件一併退還。如果無法退還損壞的零件，HP 可能要向您收取替換費用。針對客戶自行維修情形，HP 將負責所有運費及零件退還費用並指定使用何家快遞/貨運公司。

如需 HP 的「客戶自行維修」方案詳細資訊，請連絡您當地的服務供應商。至於北美方案，請參閱 HP 網站 (<http://www.hp.com/go/selfrepair>)。

## 僅限零件的保固服務

您的「HP 有限保固」可能包含僅限零件的保固服務。在僅限零件的保固服務情況下，HP 將免費提供替換零件。

針對僅限零件的保固服務，CSR 零件替換是強制性的。如果您要求 HP 更換這些零件，HP 將會向您收取此服務所需的外出費用與勞動成本。

## 고객 셀프 수리

HP 제품은 수리 시간을 최소화하고 결함이 있는 부품 교체 시 더욱 융통성을 발휘할 수 있도록 하기 위해 고객 셀프 수리(CSR) 부품을 다량 사용하여 설계되었습니다. 진단 기간 동안 HP(또는 HP 서비스 공급업체 또는 서비스 협력업체)에서 CSR 부품을 사용하여 수리가 가능하다고 판단되면 HP는 해당 부품을 바로 사용자에게 보내어 사용자가 교체할 수 있도록 합니다. CSR 부품에는 두 가지 종류가 있습니다.

- **고객 셀프 수리가 의무 사항인 필수 부품.** 사용자가 HP에 이 부품의 교체를 요청할 경우 이 서비스에 대한 출장비 및 작업비가 청구됩니다.
- **고객 셀프 수리가 선택 사항인 부품.** 이 부품들도 고객 셀프 수리가 가능하도록 설계되었습니다. 하지만 사용자가 HP에 이 부품의 교체를 요청할 경우 사용자가 구입한 제품에 해당하는 보증 서비스 유형에 따라 추가 비용 없이 교체가 가능할 수 있습니다.

**참고:** 일부 HP 부품은 고객 셀프 수리가 불가능하도록 설계되었습니다. HP는 만족스러운 고객 보증을 위해 공인 서비스 제공업체를 통해 부품을 교체하도록 하고 있습니다. 이러한 부품들은 Illustrated Parts Catalog에 "No"라고 표시되어 있습니다.

CSR 부품은 재고 상태와 지리적 조건이 허용하는 경우 다음 영업일 납품이 가능하도록 배송이 이루어집니다. 지리적 조건이 허용하는 경우 추가 비용이 청구되는 조건으로 당일 또는 4시간 배송이 가능할 수도 있습니다. 도움이 필요하시면 HP 기술 지원 센터로 전화하십시오. 전문 기술자가 전화로 도움을 줄 것입니다. HP는 결함이 발생한 부품을 HP로 반환해야 하는지 여부를 CSR 교체 부품과 함께 배송된 자료에 지정합니다. 결함이 발생한 부품을 HP로 반환해야 하는 경우에는 지정된 기간 내(통상 영업일 기준 5일)에 HP로 반환해야 합니다. 이 때 결함이 발생한 부품은 제공된 포장 재료에 넣어 관련 설명서와 함께 반환해야 합니다. 결함이 발생한 부품을 반환하지 않는 경우 HP가 교체 부품에 대해 비용을 청구할 수 있습니다. 고객 셀프 수리의 경우, HP는 모든 운송 및 부품 반환 비용을 부담하며 이용할 운송업체 및 택배 서비스를 결정합니다.

HP 고객 셀프 수리 프로그램에 대한 자세한 내용은 가까운 서비스 제공업체에 문의하십시오. 북미 지역의 프로그램에 대해서는 HP 웹 사이트(<http://www.hp.com/go/selfrepair>)를 참조하십시오.

## 부품 제공 보증 서비스

HP 제한 보증에는 부품 제공 보증 서비스가 포함될 수 있습니다. 이러한 경우 HP는 부품 제공 보증 서비스의 조건에 따라 교체 부품만을 무료로 제공합니다.

부품 제공 보증 서비스 제공 시 CSR 부품 교체는 의무 사항입니다. 사용자가 HP에 이 부품의 교체를 요청할 경우 이 서비스에 대한 출장비 및 작업비가 청구됩니다.



# Illustrated parts catalog

## Mechanical components

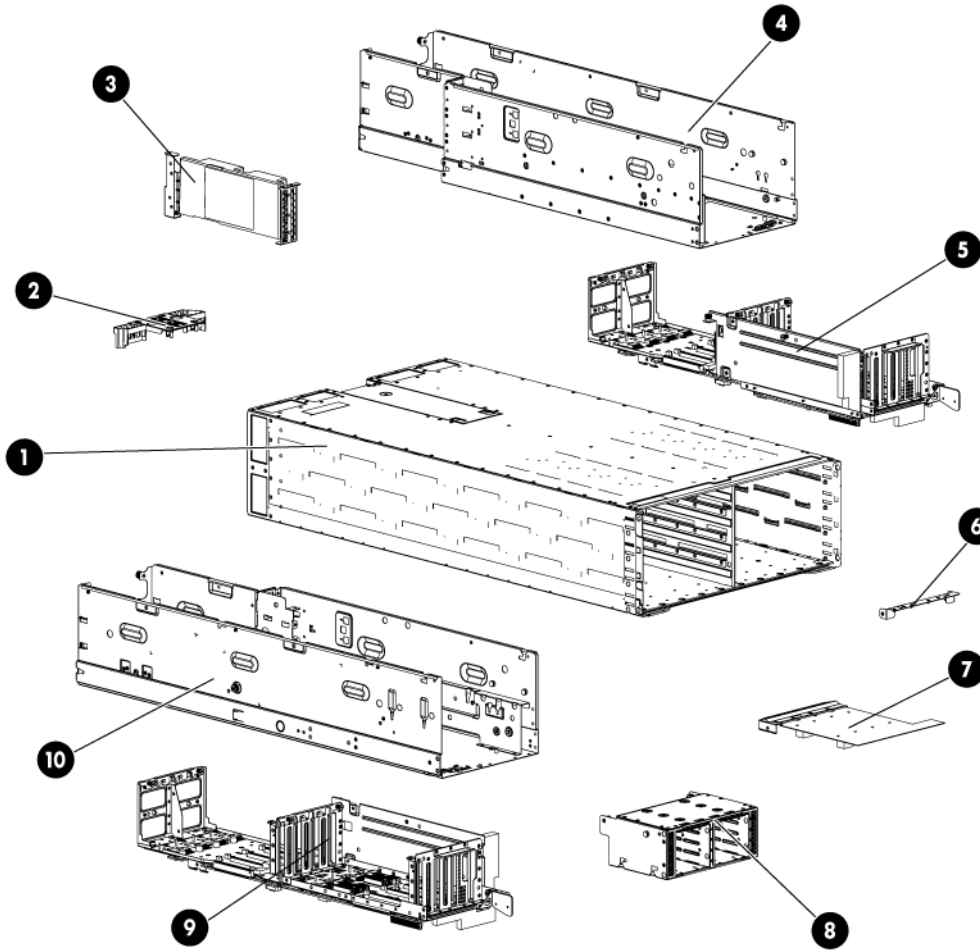

Item	Description	Spare part number	Customer self-repair ("Customer self repair" on page 5)
1	HP ProLiant s6500 Chassis	—	—
2	Processor airflow baffle	669271-001	Mandatory <sup>1</sup>
3	GPU cage blank	671769-001	Mandatory <sup>1</sup>
4	HP ProLiant SL270s Gen8 right tray	—	—
5	PCI cage and riser assembly, right	671775-001	Mandatory <sup>1</sup>
6	Shipping bracket kit	671782-001	Mandatory <sup>1</sup>
7	Baffle/shipping bracket	671780-001	Mandatory <sup>1</sup>
8	Hot-plug drive cage with backplane	671768-001	Mandatory <sup>1</sup>



Item	Description	Spare part number	Customer self-repair ("Customer self repair" on page 5)
9	PCI cage and riser assembly, left	671774-001	Mandatory <sup>1</sup>
10	HP ProLiant SL270s Gen8 left tray	—	—

<sup>1</sup>Mandatory—Parts for which customer self repair is mandatory. If you request HP to replace these parts, you will be charged for the travel and labor costs of this service.

<sup>2</sup>Optional—Parts for which customer self repair is optional. These parts are also designed for customer self repair. If, however, you require that HP replace them for you, there may or may not be additional charges, depending on the type of warranty service designated for your product.

<sup>3</sup>No—Some HP parts are not designed for customer self repair. In order to satisfy the customer warranty, HP requires that an authorized service provider replace the part. These parts are identified as "No" in the Illustrated Parts Catalog.

<sup>1</sup>Mandatory: Obligatoire—Pièces pour lesquelles la réparation par le client est obligatoire. Si vous demandez à HP de remplacer ces pièces, les coûts de déplacement et main d'œuvre du service vous seront facturés.

<sup>2</sup>Optional: Facultatif—Pièces pour lesquelles la réparation par le client est facultative. Ces pièces sont également conçues pour permettre au client d'effectuer lui-même la réparation. Toutefois, si vous demandez à HP de remplacer ces pièces, l'intervention peut ou non vous être facturée, selon le type de garantie applicable à votre produit.

<sup>3</sup>No: Non—Certaines pièces HP ne sont pas conçues pour permettre au client d'effectuer lui-même la réparation. Pour que la garantie puisse s'appliquer, HP exige que le remplacement de la pièce soit effectué par un Mainteneur Agréé. Ces pièces sont identifiées par la mention "Non" dans le Catalogue illustré.

<sup>1</sup>Mandatory: Obbligatorie—Parti che devono essere necessariamente riparate dal cliente. Se il cliente ne affida la riparazione ad HP, deve sostenere le spese di spedizione e di manodopera per il servizio.

<sup>2</sup>Optional: Opzionali—Parti la cui riparazione da parte del cliente è facoltativa. Si tratta comunque di componenti progettati per questo scopo. Se tuttavia il cliente ne richiede la sostituzione ad HP, potrebbe dover sostenere spese addizionali a seconda del tipo di garanzia previsto per il prodotto.

<sup>3</sup>No: Non CSR—Alcuni componenti HP non sono progettati per la riparazione da parte del cliente. Per rispettare la garanzia, HP richiede che queste parti siano sostituite da un centro di assistenza autorizzato. Tali parti sono identificate da un "No" nel Catalogo illustrato dei componenti.

<sup>1</sup>Mandatory: Zwingend—Teile, die im Rahmen des Customer Self Repair Programms ersetzt werden müssen. Wenn Sie diese Teile von HP ersetzen lassen, werden Ihnen die Versand- und Arbeitskosten für diesen Service berechnet.

<sup>2</sup>Optional: Optional—Teile, für die das Customer Self Repair-Verfahren optional ist. Diese Teile sind auch für Customer Self Repair ausgelegt. Wenn Sie jedoch den Austausch dieser Teile von HP vornehmen lassen möchten, können bei diesem Service je nach den für Ihr Produkt vorgesehenen Garantiebedingungen zusätzliche Kosten anfallen.

<sup>3</sup>No: Kein—Einige Teile sind nicht für Customer Self Repair ausgelegt. Um den Garantieanspruch des Kunden zu erfüllen, muss das Teil von einem HP Servicepartner ersetzt werden. Im illustrierten Teilekatalog sind diese Teile mit „No“ bzw. „Nein“ gekennzeichnet.

<sup>1</sup>Mandatory: Obligatorio—componentes para los que la reparación por parte del usuario es obligatoria. Si solicita a HP que realice la sustitución de estos componentes, tendrá que hacerse cargo de los gastos de desplazamiento y de mano de obra de dicho servicio.

<sup>2</sup>Optional: Opcional— componentes para los que la reparación por parte del usuario es opcional. Estos componentes también están diseñados para que puedan ser reparados por el usuario. Sin embargo, si precisa que HP realice su sustitución, puede o no conllevar costes adicionales, dependiendo del tipo de servicio de garantía correspondiente al producto.

<sup>3</sup>No: No—Algunos componentes no están diseñados para que puedan ser reparados por el usuario. Para que el usuario haga valer su garantía, HP pone como condición que un proveedor de servicios autorizado realice la sustitución de estos componentes. Dichos componentes se identifican con la palabra "No" en el catálogo ilustrado de componentes.

<sup>1</sup>Mandatory: Verplicht—Onderdelen waarvoor Customer Self Repair verplicht is. Als u HP verzoekt deze onderdelen te vervangen, komen de reiskosten en het arbeidsloon voor uw rekening.

<sup>2</sup>Optional: Optioneel—Onderdelen waarvoor reparatie door de klant optioneel is. Ook deze onderdelen zijn ontworpen voor reparatie door de klant. Als u echter HP verzoekt deze onderdelen voor u te vervangen, kunnen daarvoor extra kosten in rekening worden gebracht, afhankelijk van het type garanteservice voor het product.

<sup>3</sup>No: Nee—Sommige HP onderdelen zijn niet ontwikkeld voor reparatie door de klant. In verband met de garantievoorzwaarden moet het onderdeel door een geautoriseerde Service Partner worden vervangen. Deze onderdelen worden in de geïllustreerde onderdelencatalogus aangemerkt met "Nee".

<sup>1</sup>Mandatory: Obrigatória—Peças cujo reparo feito pelo cliente é obrigatório. Se desejar que a HP substitua essas peças, serão cobradas as despesas de transporte e mão-de-obra do serviço.

<sup>2</sup>Optional: Opcional—Peças cujo reparo feito pelo cliente é opcional. Essas peças também são projetadas para o reparo feito pelo cliente. No entanto, se desejar que a HP as substitua, pode haver ou não a cobrança de taxa adicional, dependendo do tipo de serviço de garantia destinado ao produto.

<sup>3</sup>No: Nenhuma—Algumas peças da HP não são projetadas para o reparo feito pelo cliente. A fim de cumprir a garantia do cliente, a HP exige que um técnico autorizado substitua a peça. Essas peças estão identificadas com a marca "No" (Não), no catálogo de peças ilustrado.

<sup>1</sup>Mandatory : 必須 - 顧客自己修理が必須の部品。当該部品について、もしもお客様がHPに交換作業を依頼される場合には、その修理サービスに関する交通費および人件費がお客様に請求されます。

<sup>2</sup>Optional : 任意 - 顧客自己修理が任意である部品。この部品も顧客自己修理用です。当該部品について、もしもお客様がHPに交換作業を依頼される場合には、お買い上げの製品に適用される保証サービス内容の範囲内においては、費用を負担していただくことなく保証サービスを受けることができます。

<sup>3</sup>No : 除外 - HP製品の一部の部品は、顧客自己修理用ではありません。製品の保証を継続するためには、HPまたはHP正規保守代理店による交換作業が必須となります。部品カタログには、当該部品が顧客自己修理除外品である旨が記載されています。

<sup>1</sup>Mandatory: 强制性的 — 要求客户必须自行维修的部件。如果您请求 HP 更换这些部件，则必须为该服务支付差旅费和人工费用。

<sup>2</sup>Optional: 可选的 — 客户可以选择是否自行维修的部件。这些部件也是为客户自行维修设计的。不过，如果您要求 HP 为您更换这些部件，则根据为您的产品指定的保修服务类型，HP 可能收取或不再收取任何附加费用。

<sup>3</sup>No: 否 — 某些 HP 部件的设计并未考虑客户自行维修。为了满足客户保修的需要，HP 要求授权服务提供商更换相关部件。这些部件在部件图解目录中标记为“否”。

<sup>1</sup>Mandatory: 強制的 — 客戶自行維修所使用的零件是強制的。如果您要求 HP 更換這些零件，HP 將會向您收取此服務所需的外出費用與勞動成本。

<sup>2</sup>Optional: 選購的 — 客戶自行維修所使用的零件是選購的。這些零件也設計用於客戶自行維修之用。不過，如果您要求 HP 為您更換，則可能需要也可能不需要負擔額外的費用，端視針對此產品指定的保固服務類型而定。

<sup>3</sup>No: 否 — 某些 HP 零件沒有消費者可自行維修的設計。為符合客戶保固，HP 需要授權的服務供應商更換零件。這些零件在圖示的零件目錄中，被標示為「否」。

<sup>1</sup> Mandatory: 필수 — 고객 셀프 수리가 의무 사항인 필수 부품. 사용자가 HP에 이 부품의 교체를 요청할 경우 이 서비스에 대한 출장비 및 작업비가 청구됩니다.

<sup>2</sup> Optional: 옵션 — 고객 셀프 수리가 선택 사항인 부품. 이 부품들도 고객 셀프 수리가 가능하도록 설계되었습니다. 하지만 사용자가 HP에 이 부품의 교체를 요청할 경우 사용자가 구입한 제품에 해당하는 보증 서비스 유형에 따라 추가 비용 없이 교체가 가능할 수 있습니다.

<sup>3</sup> No: No — 고객 셀프 수리가 불가능하도록 설계된 HP 부품. 이 부품들은 고객 셀프 수리가 불가능하도록 설계되었습니다. HP는 고객 보증을 만족시키기 위해 공인 서비스 제공업체를 통해 부품을 교체하도록 하고 있습니다.

# System components

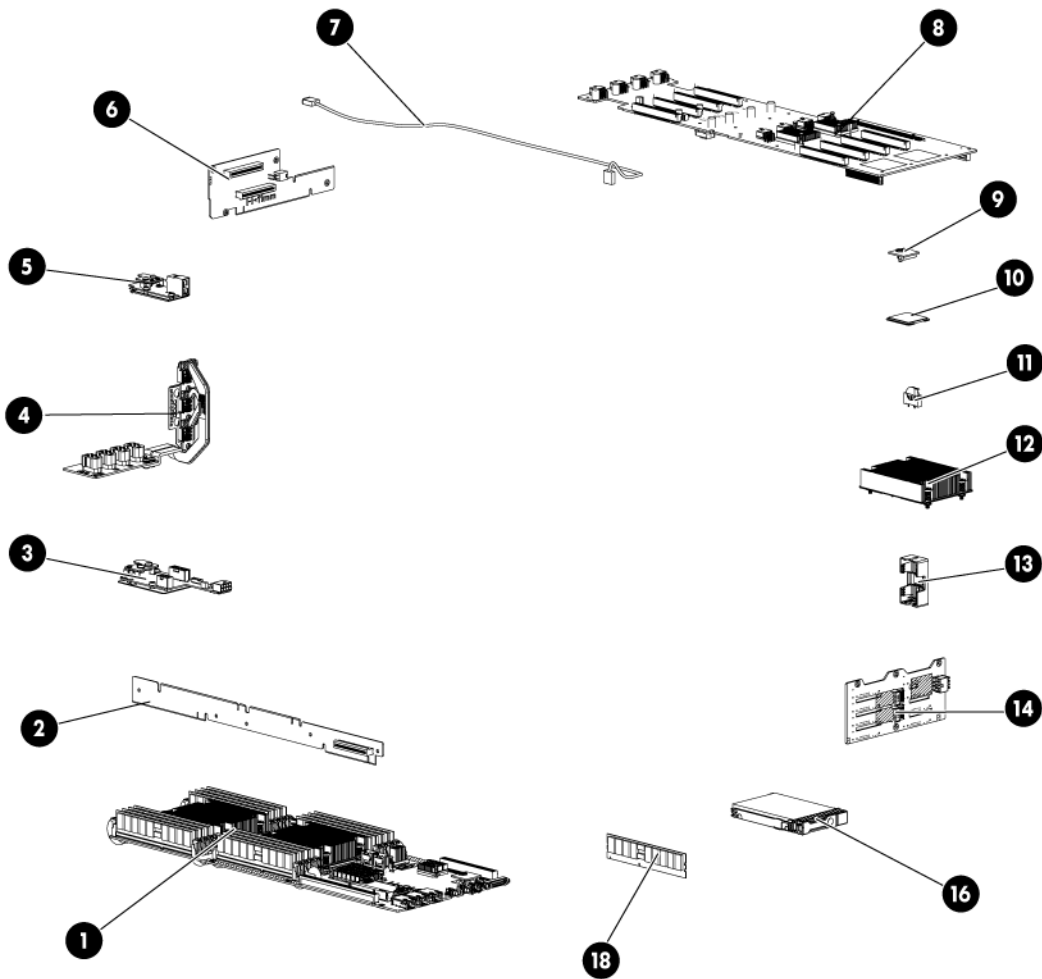

Item	Description	Spare part number	Customer self repair (on page 5)
1	System board	692492-001	Optional <sup>2</sup>
2	x16/x32 riser board	698886-001	Optional <sup>2</sup>
3	Personality boards	—	—
	a) Left node	671779-001	Optional <sup>2</sup>
	b) Right node*	701486-001	Optional <sup>2</sup>
4	Power interface boards/bus bars	—	—
	a) Left node	671776-001	Optional <sup>2</sup>
	b) Right node*	671777-001	Optional <sup>2</sup>
5	Power modules	—	—
	a) Left node	698265-001	Optional <sup>2</sup>
	b) Right node*	698266-001	Optional <sup>2</sup>

Item	Description	Spare part number	Customer self repair (on page 5)
6	x24 riser board assembly	698267-001	Optional <sup>2</sup>
7	Cables	—	—
	a) System board power cable, left*	669284-001	Mandatory <sup>1</sup>
	b) System board power cable, right*	669285-001	Mandatory <sup>1</sup>
	c) Mini-SAS cable, SFF (labeled PORT1/PORT2)*	671786-001	Mandatory <sup>1</sup>
	d) GPU power cable*	707776-001	Mandatory <sup>1</sup>
	e) Riser cable*	671788-001	Mandatory <sup>1</sup>
	f) Power cable extender*	641852-001	Mandatory <sup>1</sup>
	g) Drive mini-SAS cable*	680068-001	Mandatory <sup>1</sup>
	h) Controller cable, U-type*	680069-001	Mandatory <sup>1</sup>
	i) Controller cable, RA*	680070-001	Mandatory <sup>1</sup>
	j) Drive power cable, left*	680067-001	Mandatory <sup>1</sup>
	k) RPS cable*	692903-001	Mandatory <sup>1</sup>
	l) Power cable*	692902-001	Mandatory <sup>1</sup>
8	GPU mezzanine boards	—	—
	a) Left node	698887-001	Optional <sup>2</sup>
	b) Right node*	698888-001	Optional <sup>2</sup>
9	Trusted Platform Module	450168-001	No <sup>3</sup>
10	Processors	—	—
	a) 2.7 GHz, 20M, 130 W, Intel Xeon processor, E5-2680 8C**	670522-001	Mandatory <sup>1</sup>
	b) 2.7 GHz, 20M, 130 W, Intel Xeon processor, E5-2680 8C**	670522-001	Mandatory <sup>1</sup>
	c) 2.6 GHz, 20M, 115 W, Intel Xeon processor, E5-2670 8C**	670523-001	Mandatory <sup>1</sup>
	d) 2.4 GHz, 20M, 115 W, Intel Xeon processor, E5-2665 8C**	670524-001	Mandatory <sup>1</sup>
	e) 2.2 GHz, 20M, 95 W, Intel Xeon processor, E5-2660 8C**	670525-001	Mandatory <sup>1</sup>
	f) 2.0 GHz, 20M, 95 W, Intel Xeon processor, E5-2650 8C**	670526-001	Mandatory <sup>1</sup>
	g) 2.5 GHz, 15M, 95 W, Intel Xeon processor, E5-2640 6C**	670527-001	Mandatory <sup>1</sup>
	h) 2.3 GHz, 15M, 95 W, Intel Xeon processor, E5-2630 6C**	670528-001	Mandatory <sup>1</sup>
	i) 2.0 GHz,, 15M, 95W, Intel Xeon processor, E5-2620 6C**	670529-001	Mandatory <sup>1</sup>
	j) 2.4 GHz,, 10M, 80 W, Intel Xeon processor, E5-2609 4C**	670530-001	Mandatory <sup>1</sup>
	k) 1.8 GHz,, 10M, 80 W, Intel Xeon processor, E5-2603 4C**	670533-001	Mandatory <sup>1</sup>
	l) 1.8 GHz, 20M, 70 W, Intel Xeon processor, E5-2650L 8C LP**	670534-001	Mandatory <sup>1</sup>
	m) 2.0 GHz, 15M, 60 W, Intel Xeon processor, E5-2630L 6C**	670535-001	Mandatory <sup>1</sup>
	n) 2.9 GHz, 15M, 130 W, Intel Xeon processor, E5-2667 6C**	670537-001	Mandatory <sup>1</sup>
	o) 3.0 GHz, 5M, 80 W, Intel Xeon processor, E5-2637 2C**	670539-001	Mandatory <sup>1</sup>

Item	Description	Spare part number	Customer self repair (on page 5)
11	System battery, 3.3-V Lithium	153099-001	Mandatory <sup>1</sup>
12	Heatsinks	—	—
	a) Heatsink, processor 1	671350-001	Mandatory <sup>1</sup>
	b) Heatsink, processor 2*	671349-001	Mandatory <sup>1</sup>
13	FBWC capacitor pack holder	669291-001	Optional <sup>2</sup>
14	Drive backplane board	671348-001	Optional <sup>2</sup>
15	GPU module*	671773-001	Optional <sup>2</sup>
	<b>Drives</b>	—	—
16	HP SFF, 2.5 inch, SATA, HP/Smart Carrier drives	—	—
	a) 100 GB, 3G, MLC solid state drive	637070-001	Mandatory <sup>1</sup>
	b) 200 GB, 3G, MLC solid state drive	637071-001	Mandatory <sup>1</sup>
	c) 400 GB, 3G, MLC solid state drive	637072-001	Mandatory <sup>1</sup>
	d) 500 GB, 6G, 7,200-rpm MDL hard drive	626164-001	Mandatory <sup>1</sup>
	e) 1 TB, 6G,7,200-rpm, MDL hard drive	626165-001	Mandatory <sup>1</sup>
	f) 100 GB, 3G, MLC solid state drive	653965-001	Mandatory <sup>1</sup>
	g) 200 GB, 3G, MLC solid state drive	653966-001	Mandatory <sup>1</sup>
	h) 400 GB, 3G, MLC solid state drive	653967-001	Mandatory <sup>1</sup>
	i) 500 GB, 3G, 7,200-rpm, MDL hard drive	656104-001	Mandatory <sup>1</sup>
	j) 1 TB, 3G, 7,200-rpm, MDL hard drive	656105-001	Mandatory <sup>1</sup>
	k) 500 GB, 6G, 7,200-rpm, MDL hard drive	656107-001	Mandatory <sup>1</sup>
	l) 1 TB, 6G, 7,200-rpm, MDL hard drive	656108-001	Mandatory <sup>1</sup>
17	HP SFF, 2.5 inch, SAS, HP/Smart Carrier drives*	—	—
	a) 900 GB, 10,000-rpm, DP ENT hard drive	619463-001	Mandatory <sup>1</sup>
	b) 300 GB, 6G, 15,000-rpm, DP ENT hard drive	627195-001	Mandatory <sup>1</sup>
	c) 200 GB, SLC solid state drive	632627-001	Mandatory <sup>1</sup>
	d) 400 GB, SLC solid state drive	632630-001	Mandatory <sup>1</sup>
	e) 200 GB, MLC solid state drive	632633-001	Mandatory <sup>1</sup>
	f) 400 GB, MLC solid state drive	632636-001	Mandatory <sup>1</sup>
	g) 800 GB, MLC solid state drive	632639-001	Mandatory <sup>1</sup>
	h) 300 GB, 6G, 10,000-rpm, DP ENT hard drive	653955-001	Mandatory <sup>1</sup>
	i) 450 GB, 6G, 10,000-rpm, DP ENT hard drive	653956-001	Mandatory <sup>1</sup>
	j) 600 GB, 6G, 10,000-rpm,DP ENT hard drive	653957-001	Mandatory <sup>1</sup>
	k) 900 GB, 6G, 10,000-rpm, DP ENT hard drive	653971-001	Mandatory <sup>1</sup>
	l) 72 GB, 6G, 15,000-rpm, DP ENT hard drive	653949-001	Mandatory <sup>1</sup>
	m) 146 GB, 6G, 15,000-rpm, DP ENT hard drive	653950-001	Mandatory <sup>1</sup>

Item	Description	Spare part number	Customer self repair (on page 5)
	n) 300 GB, 6G, 15,000-rpm, DP ENT hard drive	653960-001	Mandatory <sup>1</sup>
	o) 500 GB, 6G, 7,200-rpm, DP MDL hard drive	653953-001	Mandatory <sup>1</sup>
	p) 1 TB, 6G, 7,200-rpm, DP MDL hard drive	653954-001	Mandatory <sup>1</sup>
	q) 200 GB, SLC solid state drive	653961-001	Mandatory <sup>1</sup>
	r) 400 GB, SLC solid state drive	653962-001	Mandatory <sup>1</sup>
	s) 400 GB, MLC solid state drive	653963-001	Mandatory <sup>1</sup>
	t) 800 GB, MLC solid state drive	653964-001	Mandatory <sup>1</sup>
	u) 100 GB, SLC solid state drive	657277-001	Mandatory <sup>1</sup>
	v) 200 GB, SLC solid state drive	657278-001	Mandatory <sup>1</sup>
	w) 400 GB, SLC solid state drive	657279-001	Mandatory <sup>1</sup>
	y) 100 GB, MLC solid state drive	657280-001	Mandatory <sup>1</sup>
	z) 200 GB, MLC solid state drive	657281-001	Mandatory <sup>1</sup>
	aa) 400 GB, MLC solid state drive	657282-001	Mandatory <sup>1</sup>
	bb) 800 GB, MLC solid state drive	657283-001	Mandatory <sup>1</sup>
	cc) 200 GB, MLC solid state drive	658580-001	Mandatory <sup>1</sup>
18	Memory	—	—
	a) 4 GB DIMM, PC3L-10600R, 512 Mx4	664688-001	Mandatory <sup>1</sup>
	b) 4 GB DIMM, PC3L-12800R, 512 Mx4	664689-001	Mandatory <sup>1</sup>
	c) 8 GB DIMM, PC3L-12800R, 1 Gx4	664691-001	Mandatory <sup>1</sup>
	d) 16 GB DIMM, PC3L-10600R, 1 Gx4	664692-001	Mandatory <sup>1</sup>
	e) 32 GB DIMM, PC3L-10600R, 1 Gx4	664693-001	Mandatory <sup>1</sup>
	f) 2 GB DIMM, PC3L-10600E, 256 Mx8	664694-001	Mandatory <sup>1</sup>
	g) 4 GB DIMM, PC3L-10600R, 256 Mx8	664695-001	Mandatory <sup>1</sup>
	h) 8 GB DIMM, PC3L-10600R, 512 Mx8	664696-001	Mandatory <sup>1</sup>

\*Not shown

\*\*All processors in this HP ProLiant server must have the same cache size, speed, number of cores, and rated maximum power consumption.

<sup>1</sup>Mandatory—Parts for which customer self repair is mandatory. If you request HP to replace these parts, you will be charged for the travel and labor costs of this service.

<sup>2</sup>Optional—Parts for which customer self repair is optional. These parts are also designed for customer self repair. If, however, you require that HP replace them for you, there may or may not be additional charges, depending on the type of warranty service designated for your product.

<sup>3</sup>No—Some HP parts are not designed for customer self repair. In order to satisfy the customer warranty, HP requires that an authorized service provider replace the part. These parts are identified as "No" in the Illustrated Parts Catalog.

<sup>1</sup>Mandatory: Obligatoire—Pièces pour lesquelles la réparation par le client est obligatoire. Si vous demandez à HP de remplacer ces pièces, les coûts de déplacement et main d'œuvre du service vous seront facturés.

<sup>2</sup>Optional: Facultatif—Pièces pour lesquelles la réparation par le client est facultative. Ces pièces sont également conçues pour permettre au client d'effectuer lui-même la réparation. Toutefois, si vous demandez à HP de remplacer ces pièces, l'intervention peut ou non vous être facturée, selon le type de garantie applicable à votre produit.

<sup>3</sup>No: Non—Certaines pièces HP ne sont pas conçues pour permettre au client d'effectuer lui-même la réparation. Pour que la garantie puisse s'appliquer, HP exige que le remplacement de la pièce soit effectué par un Mainteneur Agréé. Ces pièces sont identifiées par la mention "Non" dans le Catalogue illustré.

<sup>1</sup>Mandatory: Obbligatorie—Parti che devono essere necessariamente riparate dal cliente. Se il cliente ne affida la riparazione ad HP, deve sostenere le spese di spedizione e di manodopera per il servizio.

<sup>2</sup>Optional: Opzionali—Parti la cui riparazione da parte del cliente è facoltativa. Si tratta comunque di componenti progettati per questo scopo. Se tuttavia il cliente ne richiede la sostituzione ad HP, potrebbe dover sostenere spese aggiuntive a seconda del tipo di garanzia previsto per il prodotto.

<sup>3</sup>No: Non CSR—Alcuni componenti HP non sono progettati per la riparazione da parte del cliente. Per rispettare la garanzia, HP richiede che queste parti siano sostituite da un centro di assistenza autorizzato. Tali parti sono identificate da un "No" nel Catalogo illustrato dei componenti.

<sup>1</sup>Mandatory: Zwingend—Teile, die im Rahmen des Customer Self Repair Programms ersetzt werden müssen. Wenn Sie diese Teile von HP ersetzen lassen, werden Ihnen die Versand- und Arbeitskosten für diesen Service berechnet.

<sup>2</sup>Optional: Optional—Teile, für die das Customer Self Repair-Verfahren optional ist. Diese Teile sind auch für Customer Self Repair ausgelegt. Wenn Sie jedoch den Austausch dieser Teile von HP vornehmen lassen möchten, können bei diesem Service je nach den für Ihr Produkt vorgesehenen Garantiebedingungen zusätzliche Kosten anfallen.

<sup>3</sup>No: Kein—Einige Teile sind nicht für Customer Self Repair ausgelegt. Um den Garantieanspruch des Kunden zu erfüllen, muss das Teil von einem HP Servicepartner ersetzt werden. Im illustrierten Teilekatalog sind diese Teile mit „No“ bzw. „Nein“ gekennzeichnet.

<sup>1</sup>Mandatory: Obligatorio—componentes para los que la reparación por parte del usuario es obligatoria. Si solicita a HP que realice la sustitución de estos componentes, tendrá que hacerse cargo de los gastos de desplazamiento y de mano de obra de dicho servicio.

<sup>2</sup>Optional: Opcional— componentes para los que la reparación por parte del usuario es opcional. Estos componentes también están diseñados para que puedan ser reparados por el usuario. Sin embargo, si precisa que HP realice su sustitución, puede o no conllevar costes adicionales, dependiendo del tipo de servicio de garantía correspondiente al producto.

<sup>3</sup>No: No—Algunos componentes no están diseñados para que puedan ser reparados por el usuario. Para que el usuario haga valer su garantía, HP pone como condición que un proveedor de servicios autorizado realice la sustitución de estos componentes. Dichos componentes se identifican con la palabra "No" en el catálogo ilustrado de componentes.

<sup>1</sup>Mandatory: Verplicht—Onderdelen waarvoor Customer Self Repair verplicht is. Als u HP verzoekt deze onderdelen te vervangen, komen de reiskosten en het arbeidsloon voor uw rekening.

<sup>2</sup>Optional: Optioneel—Onderdelen waarvoor reparatie door de klant optioneel is. Ook deze onderdelen zijn ontworpen voor reparatie door de klant. Als u echter HP verzoekt deze onderdelen voor u te vervangen, kunnen daarvoor extra kosten in rekening worden gebracht, afhankelijk van het type garantieservice voor het product.

<sup>3</sup>No: Nee—Sommige HP onderdelen zijn niet ontwikkeld voor reparatie door de klant. In verband met de garantievoorwaarden moet het onderdeel door een geautoriseerde Service Partner worden vervangen. Deze onderdelen worden in de geïllustreerde onderdelencatalogus aangemerkt met "Nee".

<sup>1</sup>Mandatory: Obrigatória—Peças cujo reparo feito pelo cliente é obrigatório. Se desejar que a HP substitua essas peças, serão cobradas as despesas de transporte e mão-de-obra do serviço.

<sup>2</sup>Optional: Opcional—Peças cujo reparo feito pelo cliente é opcional. Essas peças também são projetadas para o reparo feito pelo cliente. No entanto, se desejar que a HP as substitua, pode haver ou não a cobrança de taxa adicional, dependendo do tipo de serviço de garantia destinado ao produto.

<sup>3</sup>No: Nenhuma—Algumas peças da HP não são projetadas para o reparo feito pelo cliente. A fim de cumprir a garantia do cliente, a HP exige que um técnico autorizado substitua a peça. Essas peças estão identificadas com a marca "No" (Não), no catálogo de peças ilustrado.

<sup>1</sup>Mandatory : 必須 - 顧客自己修理が必須の部品。当該部品について、もしもお客様がHPに交換作業を依頼される場合には、その修理サービスに関する交通費および人件費がお客様に請求されます。

<sup>2</sup>Optional : 任意 - 顧客自己修理が任意である部品。この部品も顧客自己修理用です。当該部品について、もしもお客様がHPに交換作業を依頼される場合には、お買い上げの製品に適用される保証サービス内容の範囲内においては、費用を負担していただくことなく保証サービスを受けることができます。

<sup>3</sup>No : 除外 - HP製品の一部の部品は、顧客自己修理用ではありません。製品の保証を継続するためには、HPまたはHP正規保守代理店による交換作業が必須となります。部品カタログには、当該部品が顧客自己修理除外品である旨が記載されています。

<sup>1</sup>Mandatory: 强制性的 — 要求客户必须自行维修的部件。如果您请求 HP 更换这些部件，则必须为该服务支付差旅费和人工费用。

<sup>2</sup>Optional: 可选的 — 客户可以选择是否自行维修的部件。这些部件也是为客户自行维修设计的。不过，如果您要求 HP 为您更换这些部件，则根据您的产品指定的保修服务类型，HP 可能收取或不再收取任何附加费用。

<sup>3</sup>No: 否 — 某些 HP 部件的设计并未考虑客户自行维修。为了满足客户保修的需要，HP 要求授权服务提供商更换相关部件。这些部件在部件图解目录中标记为“否”。

<sup>1</sup>Mandatory: 強制的 — 客戶自行維修所使用的零件是強制性的。如果您要求 HP 更換這些零件，HP 將會向您收取此服務所需的外出費用與勞動成本。

<sup>2</sup>Optional: 選購的 — 客戶自行維修所使用的零件是選購的。這些零件也設計用於客戶自行維修之用。不過，如果您要求 HP 為您更換，則可能需要也可能不需要負擔額外的費用，端視針對此產品指定的保固服務類型而定。

<sup>3</sup>No: 否 — 某些 HP 零件沒有消費者可自行維修的設計。為符合客戶保固，HP 需要授權的服務供應商更換零件。這些零件在圖示的零件目錄中，被標示為「否」。

<sup>1</sup> Mandatory: 필수 — 고객 셀프 수리가 의무 사항인 필수 부품. 사용자가 HP에 이 부품의 교체를 요청할 경우 이 서비스에 대한 출장비 및 작업비가 청구됩니다.

<sup>2</sup> Optional: 옵션 — 고객 셀프 수리가 선택 사항인 부품. 이 부품들도 고객 셀프 수리가 가능하도록 설계되었습니다. 하지만 사용자가 HP에 이 부품의 교체를 요청할 경우 사용자가 구입한 제품에 해당하는 보증 서비스 유형에 따라 추가 비용 없이 교체가 가능할 수 있습니다.

<sup>3</sup> No: No — 고객 셀프 수리가 불가능하도록 설계된 HP 부품. 이 부품들은 고객 셀프 수리가 불가능하도록 설계되었습니다. HP는 고객 보증을 만족시키기 위해 공인 서비스 제공업체를 통해 부품을 교체하도록 하고 있습니다.



---

# Removal and replacement procedures

## Required tools

You need the following items for some procedures:

- T-10/T-15 Torx screwdriver (provided inside the server)
- HP Insight Diagnostics software ("HP Insight Diagnostics" on page 58)

## Safety considerations

Before performing service procedures, review all the safety information.

### Preventing electrostatic discharge

To prevent damaging the system, be aware of the precautions you need to follow when setting up the system or handling parts. A discharge of static electricity from a finger or other conductor may damage system boards or other static-sensitive devices. This type of damage may reduce the life expectancy of the device.

To prevent electrostatic damage:

- Avoid hand contact by transporting and storing products in static-safe containers.
- Keep electrostatic-sensitive parts in their containers until they arrive at static-free workstations.
- Place parts on a grounded surface before removing them from their containers.
- Avoid touching pins, leads, or circuitry.
- Always be properly grounded when touching a static-sensitive component or assembly.

## Symbols on equipment

The following symbols may be placed on equipment to indicate the presence of potentially hazardous conditions.



This symbol indicates the presence of hazardous energy circuits or electric shock hazards. Refer all servicing to qualified personnel.

**WARNING:** To reduce the risk of injury from electric shock hazards, do not open this enclosure. Refer all maintenance, upgrades, and servicing to qualified personnel.



This symbol indicates the presence of electric shock hazards. The area contains no user or field serviceable parts. Do not open for any reason.

**WARNING:** To reduce the risk of injury from electric shock hazards, do not open this enclosure.



This symbol on an RJ-45 receptacle indicates a network interface connection.

**WARNING:** To reduce the risk of electric shock, fire, or damage to the equipment, do not plug telephone or telecommunications connectors into this receptacle.

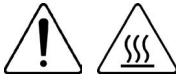

This symbol indicates the presence of a hot surface or hot component. If this surface is contacted, the potential for injury exists.

**WARNING:** To reduce the risk of injury from a hot component, allow the surface to cool before touching.

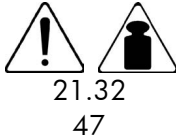

This symbol indicates that the component exceeds the recommended weight for one individual to handle safely.

**WARNING:** To reduce the risk of personal injury or damage to the equipment, observe local occupational health and safety requirements and guidelines for manual material handling.



These symbols, on power supplies or systems, indicate that the equipment is supplied by multiple sources of power.

**WARNING:** To reduce the risk of injury from electric shock, remove all power cords to completely disconnect power from the system.

## Server warnings and cautions

Before installing a server, be sure that you understand the following warnings and cautions.



**WARNING:** To reduce the risk of electric shock or damage to the equipment:

- Do not disable the power cord grounding plug. The grounding plug is an important safety feature.
- Plug the power cord into a grounded (earthed) electrical outlet that is easily accessible at all times.
- Unplug the power cord from the power supply to disconnect power to the equipment.
- Do not route the power cord where it can be walked on or pinched by items placed against it. Pay particular attention to the plug, electrical outlet, and the point where the cord extends from the server.



**WARNING:** To reduce the risk of personal injury from hot surfaces, allow the drives and the internal system components to cool before touching them.



**CAUTION:** Do not operate the server for long periods with the access panel open or removed. Operating the server in this manner results in improper airflow and improper cooling that can lead to thermal damage.

## Preparation procedures

To access some components and perform certain service procedures, you must perform one or both of the following procedures:

- Power down the server (on page 27).

If you must remove a server from a rack or a non-hot-plug component from a server, then you must power down the server.

- Remove the server from the chassis (on page 27).  
If the rack environment, cabling configuration, or the server location in the rack creates unstable conditions, then remove the server from the chassis.

## Power down the server

Before powering down the server for any upgrade or maintenance procedures, perform a backup of critical server data and programs.



---

**IMPORTANT:** When the server is in standby mode, auxiliary power is still being provided to the system.

---

To power down the server, use one of the following methods:

- Press and release the Power On/Standby button.  
This method initiates a controlled shutdown of applications and the OS before the server enters standby mode.
- Press and hold the Power On/Standby button for more than 4 seconds to force the server to enter standby mode.  
This method forces the server to enter standby mode without properly exiting applications and the OS. If an application stops responding, you can use this method to force a shutdown.
- Use a virtual power button selection through iLO 4.  
This method initiates a controlled remote shutdown of applications and the OS before the server enters standby mode.

Before proceeding, verify the server is in standby mode by observing that the system power LED is amber.

## Remove the server from the chassis



---

**WARNING:** This server is very heavy. To reduce the risk of personal injury or damage to the equipment:

- Observe local occupational health and safety requirements and guidelines for manual material handling.
  - Get help to lift and stabilize the product during installation or removal, especially when the product is not fastened to the rails. HP recommends that a minimum of two people are required for all rack server installations. A third person may be required to help align the server if the server is installed higher than chest level.
  - Use caution when installing the server in or removing the server from the rack; it is unstable when not fastened to the rails.
- 

1. Power down the server (on page 27).
2. Disconnect all peripheral cables and power cords.

3. Remove the server from the chassis.

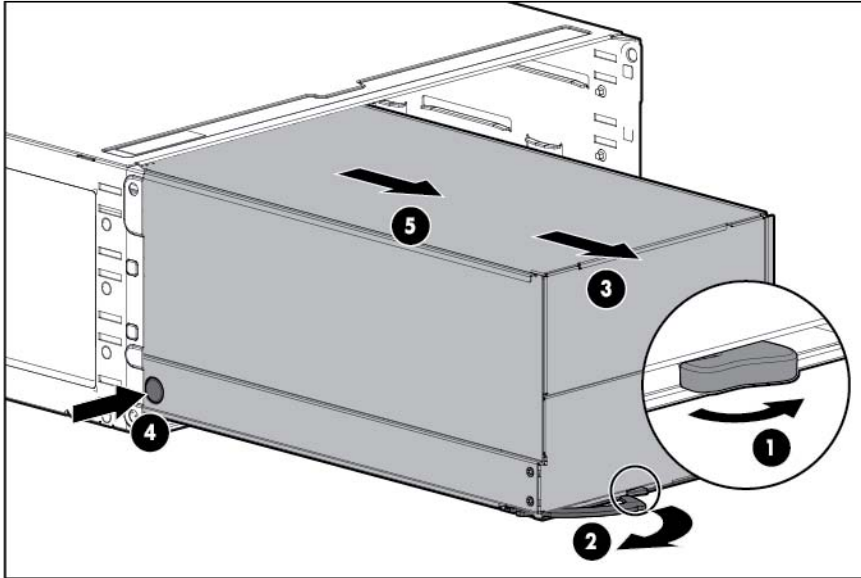

## Drive blank

- △ **CAUTION:** To prevent improper cooling and thermal damage, do not operate the server unless all bays are populated with either a component or a blank.

Remove the drive blank.

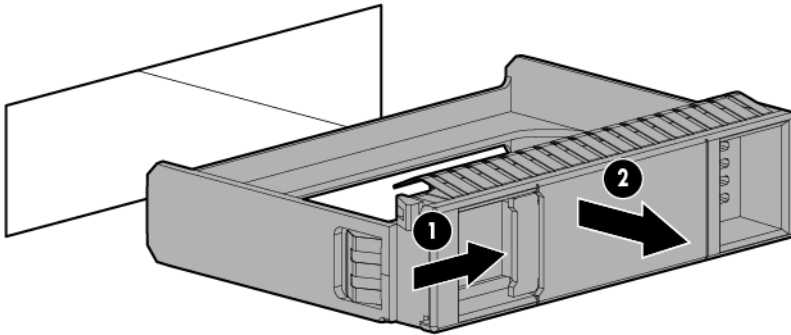

To replace the component, slide the component into the bay until it clicks.

## Hot-plug drive

To remove the component:

1. Determine the status of the drive from the drive LED definitions (on page 65).
2. Back up all server data on the drive.

3. Remove the drive.

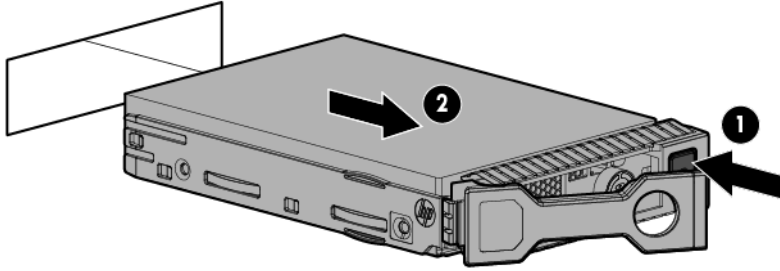

To replace the component:

**CAUTION:** To prevent improper cooling and thermal damage, do not operate the server or the enclosure unless all drive and device bays are populated with either a component or a blank.

1. Prepare the drive.

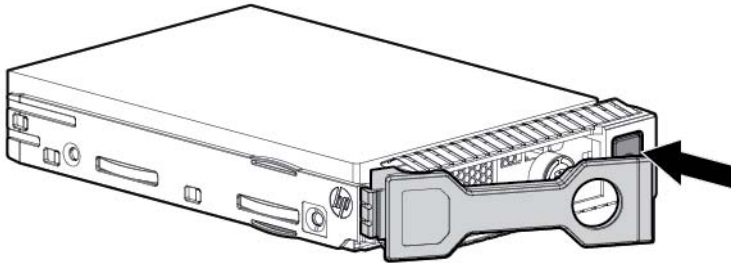

2. Install the drive.

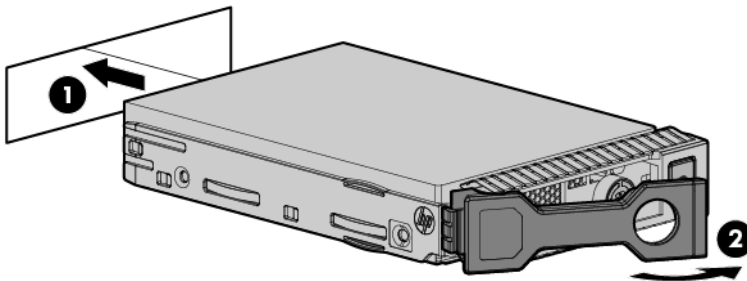

Determine the status of the drive from the drive LED definitions (on page 65).

## Hot-plug drive cage

To remove the component:

1. Power down the server (on page 27).
2. Disconnect all peripheral cables from the server.

3. Remove the server from the chassis (on page 27).
4. Remove all hard drives ("Hot-plug drive" on page 28) and hard drive blanks ("Drive blank" on page 28).
5. Remove all cables connected to the drive backplane.
6. Remove the hot-plug drive cage.

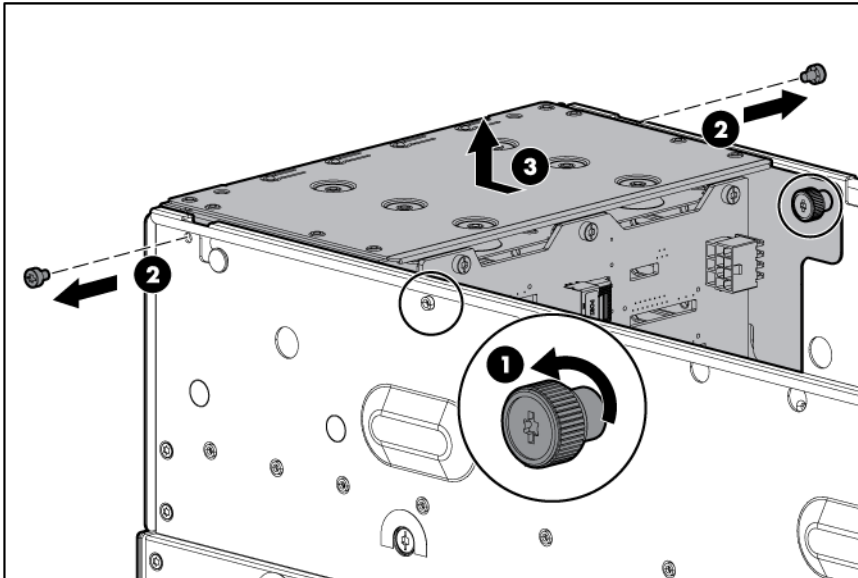

To replace the component, reverse the removal procedure.

## Expansion boards

To remove the component:

1. Power down the server (on page 27).
2. Disconnect all peripheral cables from the server.
3. Remove the server from the chassis (on page 27).
4. Remove the hot-plug drive cage ("Hot-plug drive cage" on page 29).
5. Remove the PCI riser board assembly ("PCI riser board assembly" on page 31).

6. Remove the expansion board.

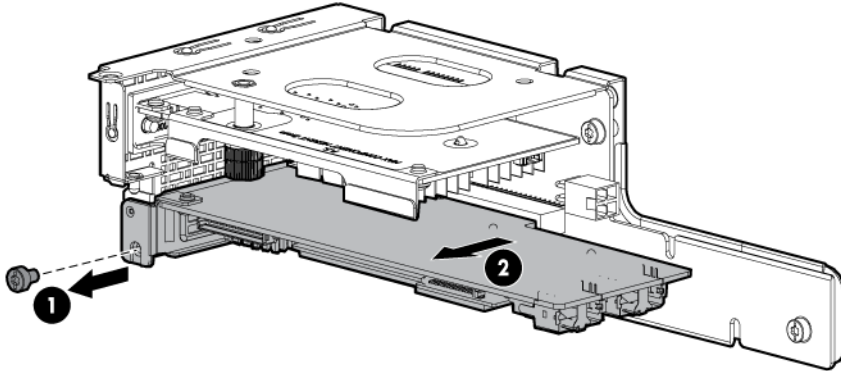

To replace the component, reverse the removal procedure.

## PCI riser board assembly

To remove the component:

1. Power down the server (on page 27).
2. Disconnect all peripheral cables from the server.
3. Remove the server from the chassis (on page 27).
4. Remove the hot-plug drive cage ("Hot-plug drive cage" on page 29).
5. Remove all shipping brackets.

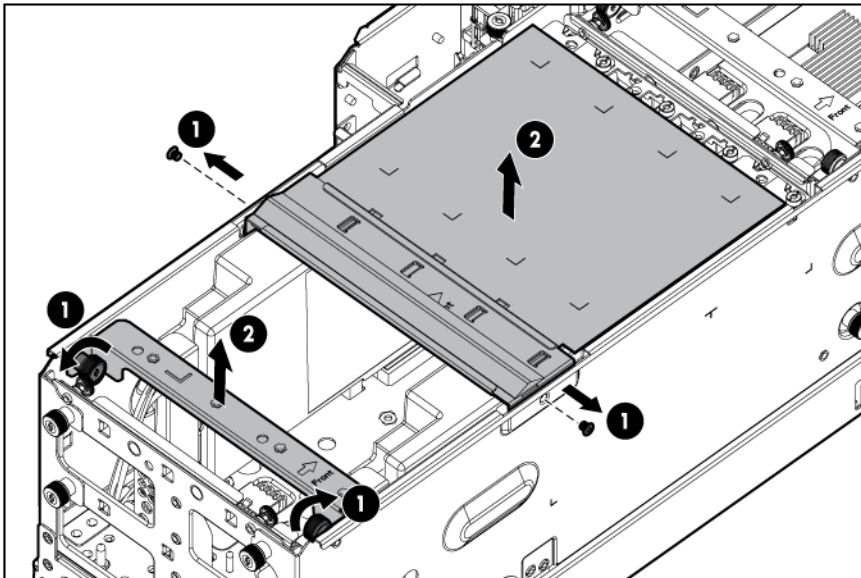

6. Remove the GPU shelf ("GPU shelf" on page 35).

7. Remove the PCI cage.

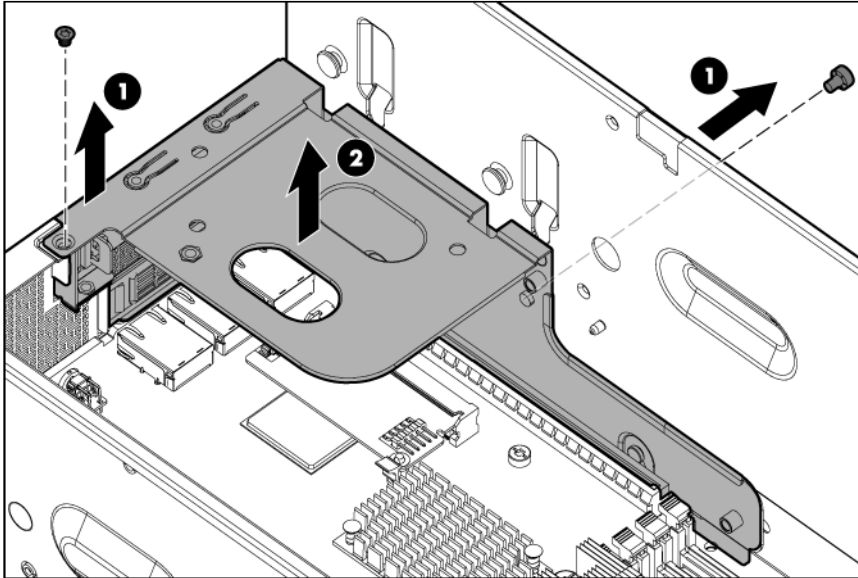

8. Remove the PCI riser board.

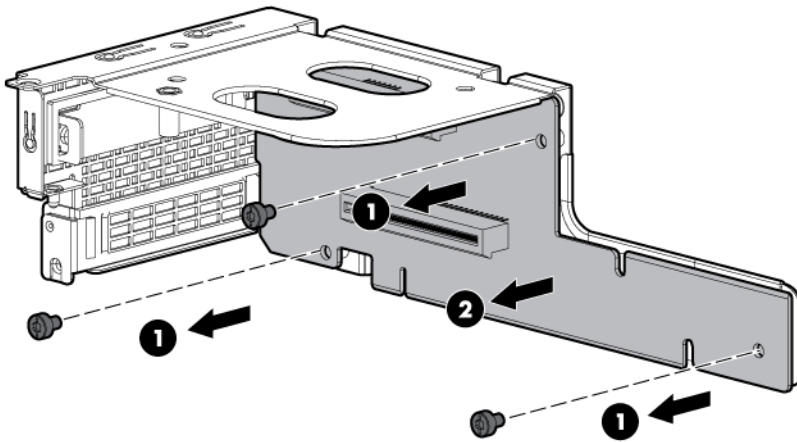

To replace the component, reverse the removal procedure.

## x16/x32 riser board assembly

To remove the component:

1. Power down the server (on page 27).
2. Disconnect all peripheral cables from the server.
3. Remove the server from the chassis (on page 27).
4. Remove the hot-plug drive cage ("Hot-plug drive cage" on page 29).



5. Remove all shipping brackets.

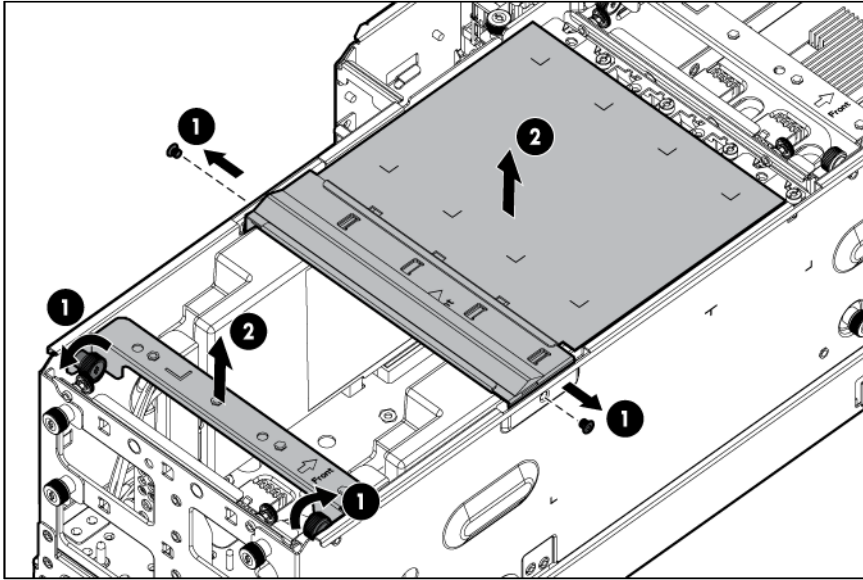

6. Remove the GPU shelf ("GPU shelf" on page 35).
7. Remove the two screws securing the x16/x32 riser board assembly to the system tray.
8. To release and remove the riser board assembly, pull the two blue handles at each end of the riser board assembly.

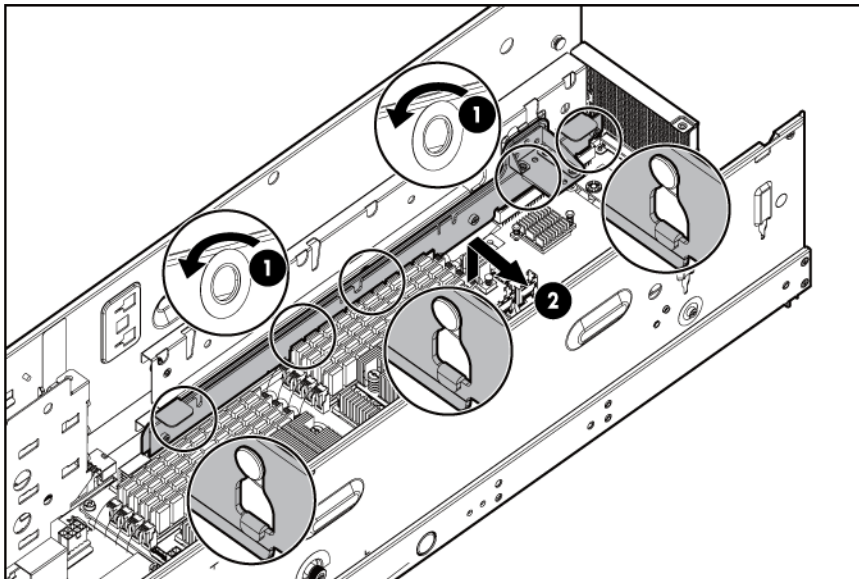

9. Remove the five screws securing the x16/x32 riser board to the bracket.

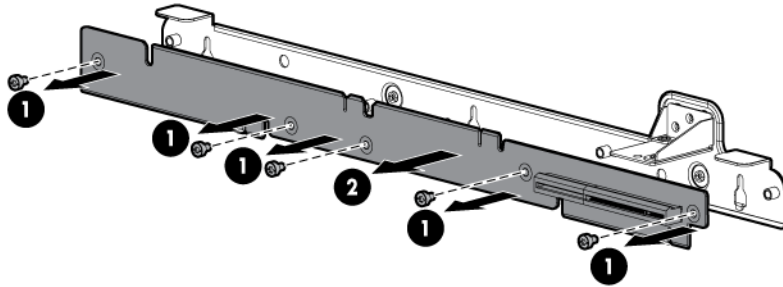

To replace the component, reverse the removal procedure.

## GPU module

To remove the component:

1. Power down the server (on page 27).
2. Disconnect all peripheral cables from the server.
3. Remove the server from the chassis (on page 27).
4. Remove the shipping brackets.

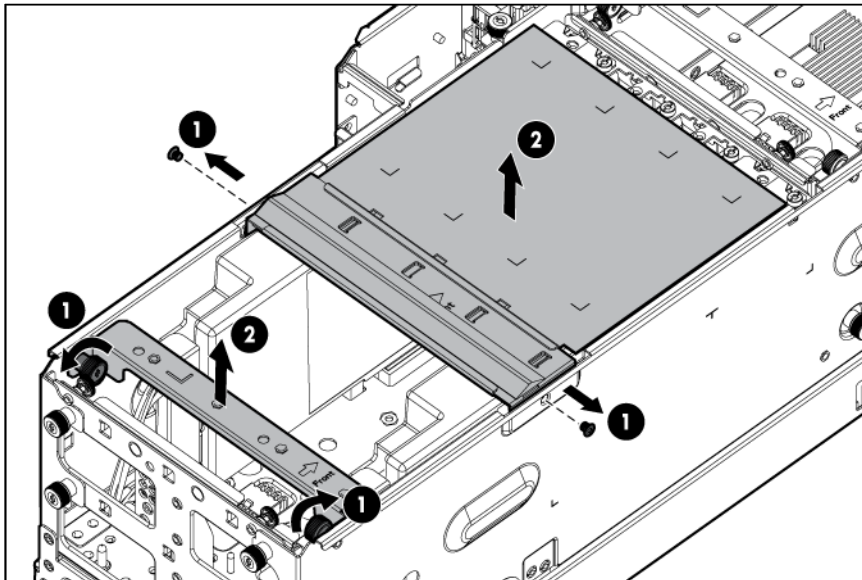

5. Remove the GPU power cable.

6. Remove the GPU module or blank.

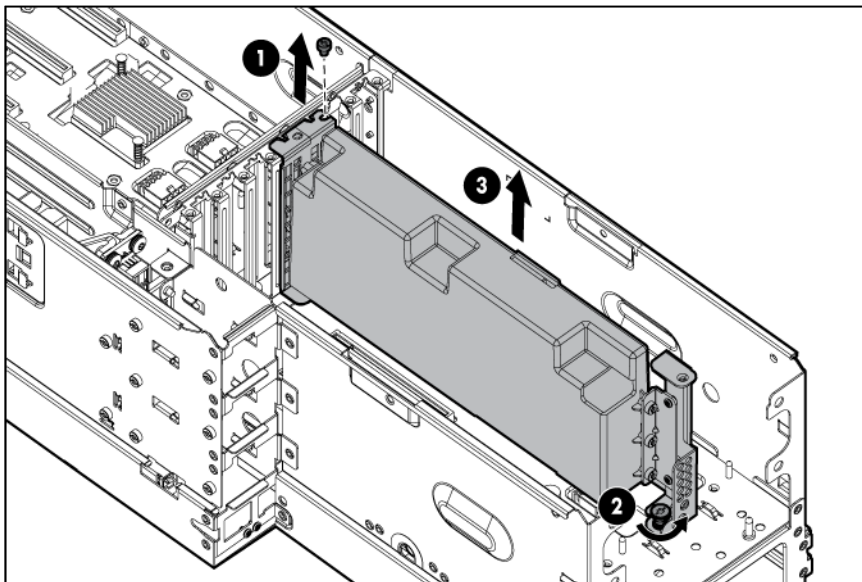
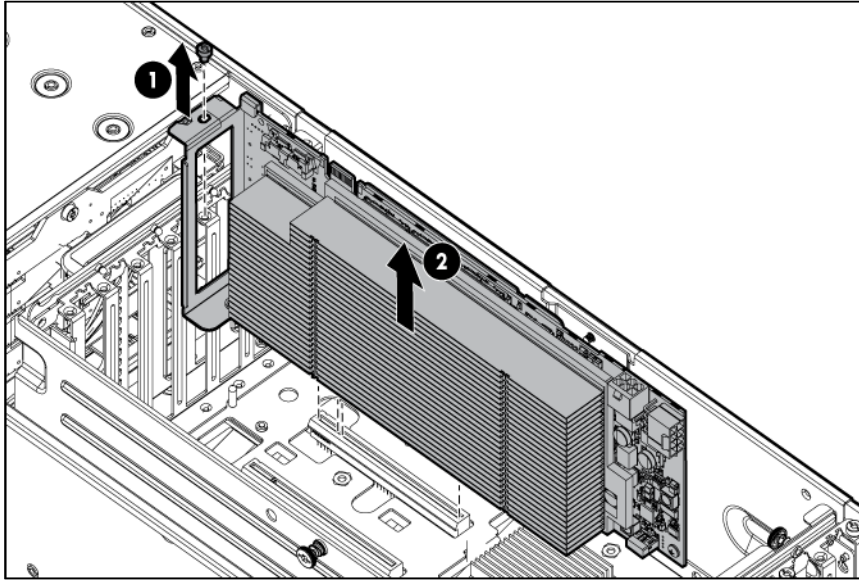

To replace the component, reverse the removal procedure.

## GPU shelf

To remove the component:

1. Power down the server (on page 27).
2. Disconnect all peripheral cables from the server.
3. Remove the server from the chassis (on page 27).
4. Remove the hot-plug drive cage ("Hot-plug drive cage" on page 29).

5. Remove all shipping brackets.

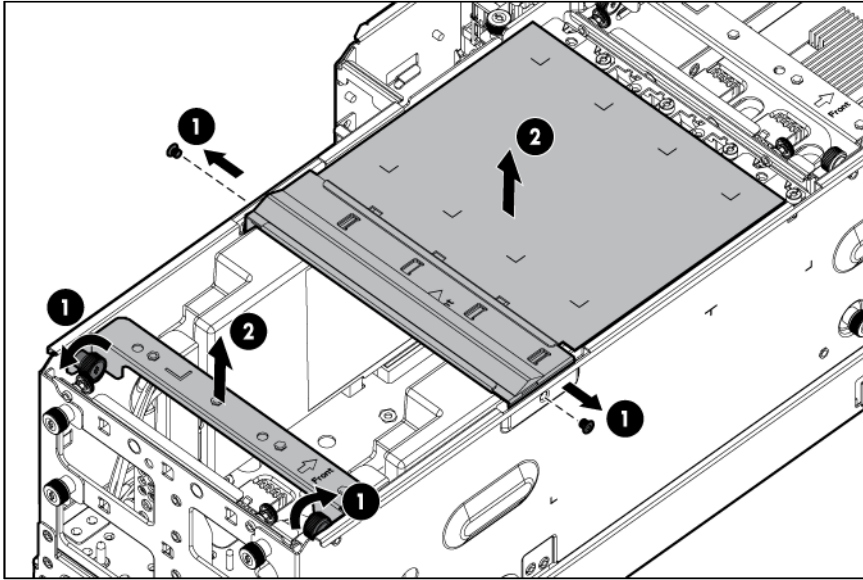

6. Loosen screws securing the GPU shelf.

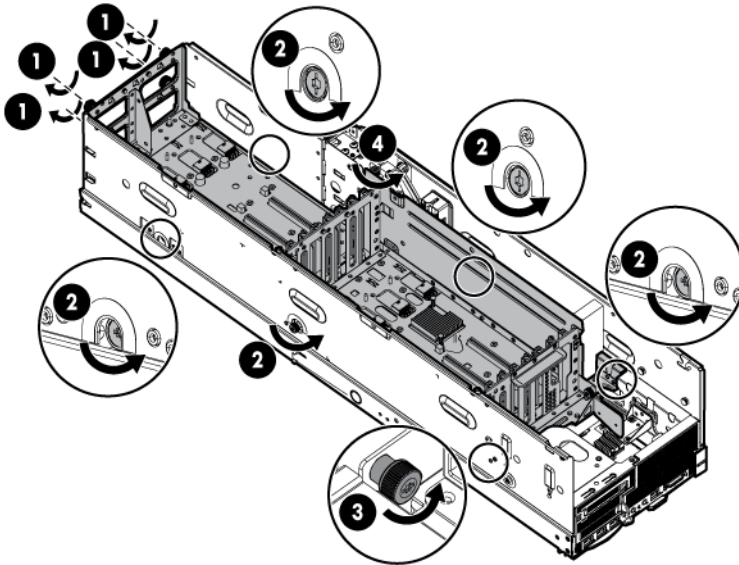

7. Remove the GPU shelf.

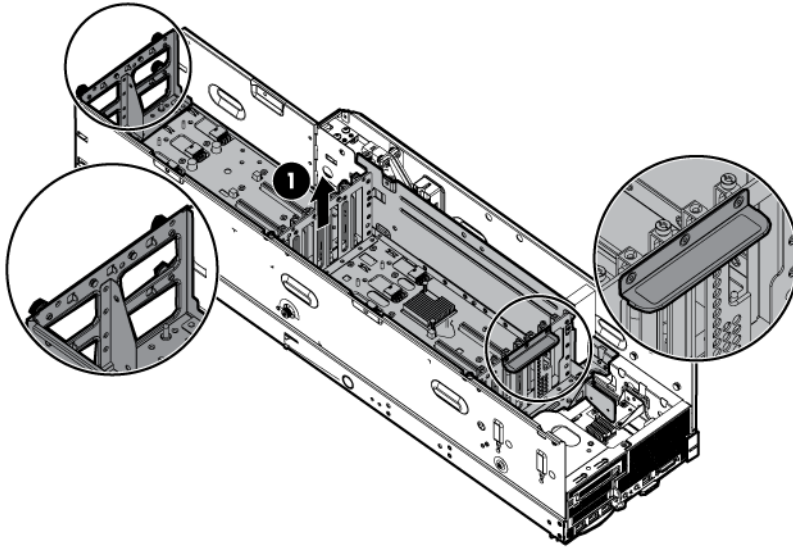

**IMPORTANT:** To avoid damage to the power connectors, lift the front and back of the GPU shelf simultaneously, maintaining a level orientation.

To replace the component, reverse the removal procedure.

## Mezzanine board

To remove the component:

1. Power down the server (on page 27).
2. Disconnect all peripheral cables from the server.
3. Remove the server from the chassis (on page 27).
4. Remove the hot-plug drive cage ("Hot-plug drive cage" on page 29).
5. Remove all shipping brackets.

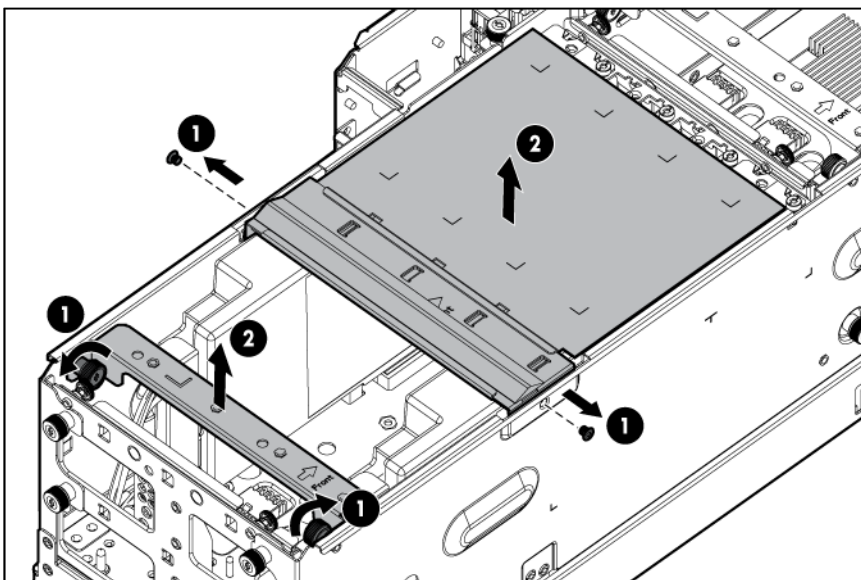



6. Remove the GPU shelf ("GPU shelf" on page 35).
7. Remove all GPU modules and blanks ("GPU module" on page 34).
8. Disconnect the eight power cables from the top of the mezzanine board, and then turn the GPU shelf over.
9. Remove the mezzanine board:
  - a. Remove the six screws securing the metal shield.
  - b. Lift and remove the metal shield.
  - c. Remove the screws securing the mezzanine board to the GPU shelf.
  - d. Lift the mezzanine board.

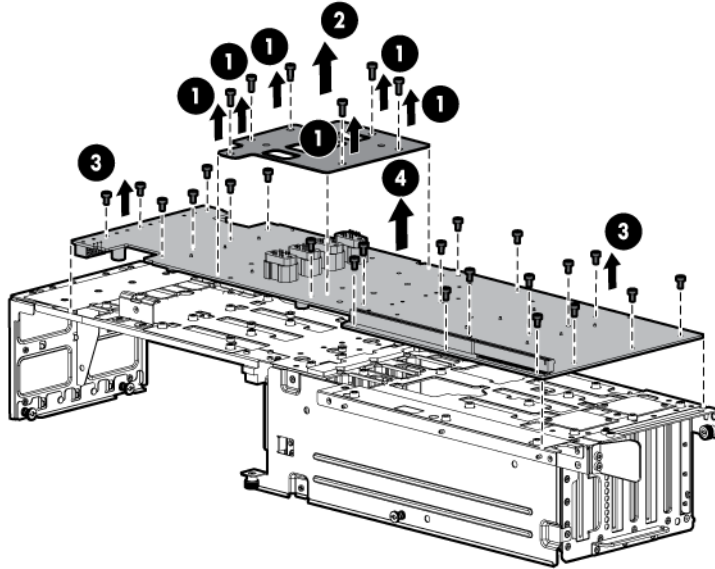

To replace the component, reverse the removal procedure.

## FBWC capacitor pack



**CAUTION:** To prevent a server malfunction or damage to the equipment, do not add or remove the battery pack while an array capacity expansion, RAID level migration, or stripe size migration is in progress.

To remove the component:

1. Power down the server (on page 27).
2. Disconnect all peripheral cables from the server.
3. Remove the server from the chassis (on page 27).
4. Remove the hot-plug drive cage ("Hot-plug drive cage" on page 29).

5. Remove all shipping brackets.

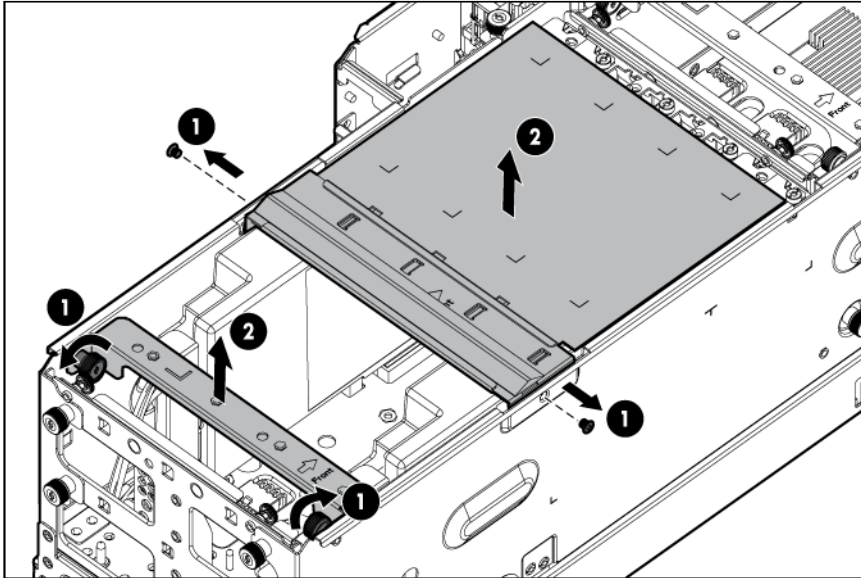

6. Remove the GPU shelf ("GPU shelf" on page 35).
7. Remove the FBWC capacitor pack.

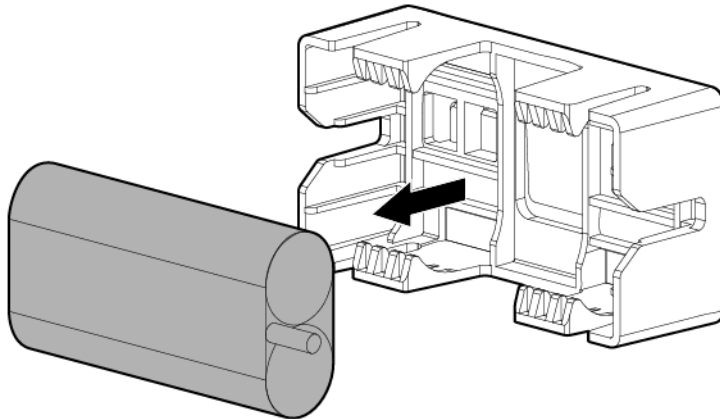

To replace the component, reverse the removal procedure.

## FBWC capacitor pack holder

**CAUTION:** To prevent a server malfunction or damage to the equipment, do not add or remove the battery pack while an array capacity expansion, RAID level migration, or stripe size migration is in progress.

To remove the component:

1. Power down the server (on page 27).
2. Disconnect all peripheral cables from the server.

3. Remove the server from the chassis (on page 27).
4. Remove the hot-plug drive cage ("Hot-plug drive cage" on page 29).
5. Remove all shipping brackets.

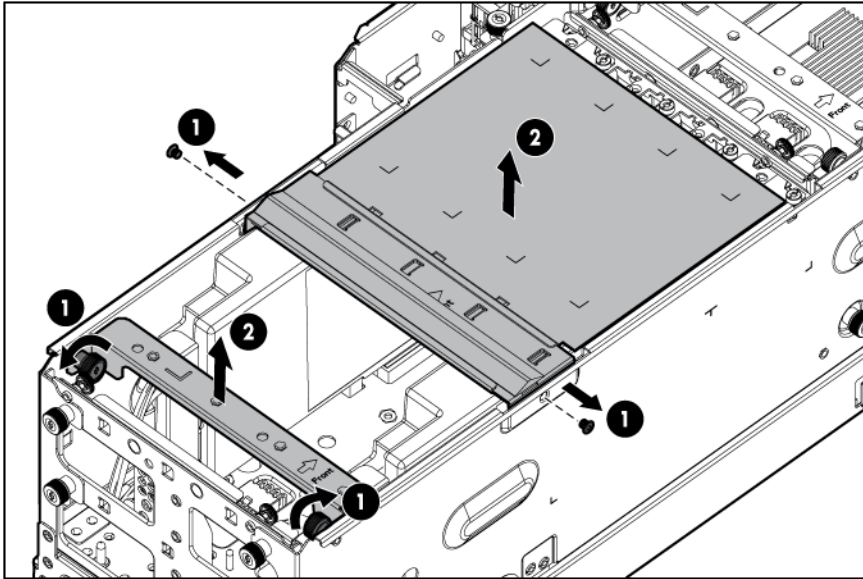

6. Remove the GPU shelf ("GPU shelf" on page 35).
7. If installed, remove the FBWC capacitor pack ("FBWC capacitor pack" on page 38).
8. Remove the FBWC capacitor pack holder.

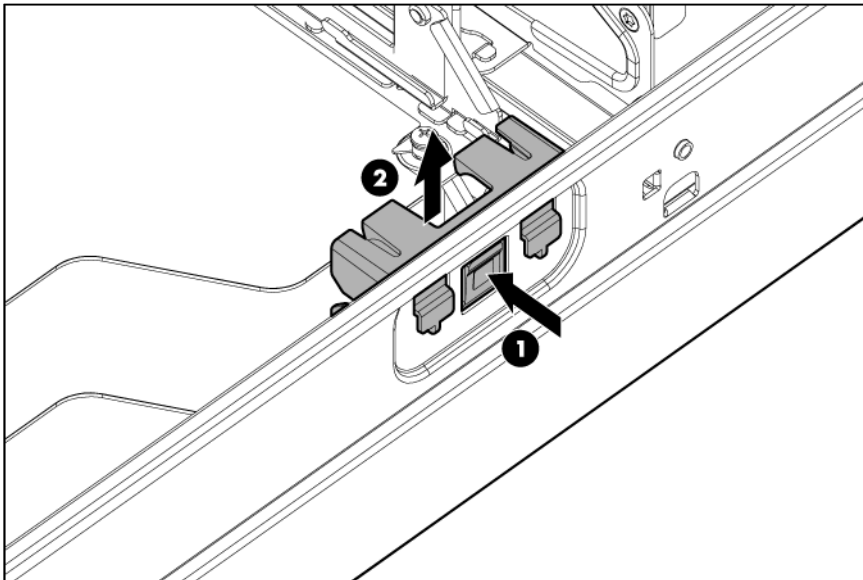

To replace the component, reverse the removal procedure.

## Processor air baffle

To remove the component:

1. Power down the server (on page 27).
2. Disconnect all peripheral cables from the server.



3. Remove the server from the chassis (on page 27).
4. Remove the hot-plug drive cage ("Hot-plug drive cage" on page 29).
5. Remove all shipping brackets.

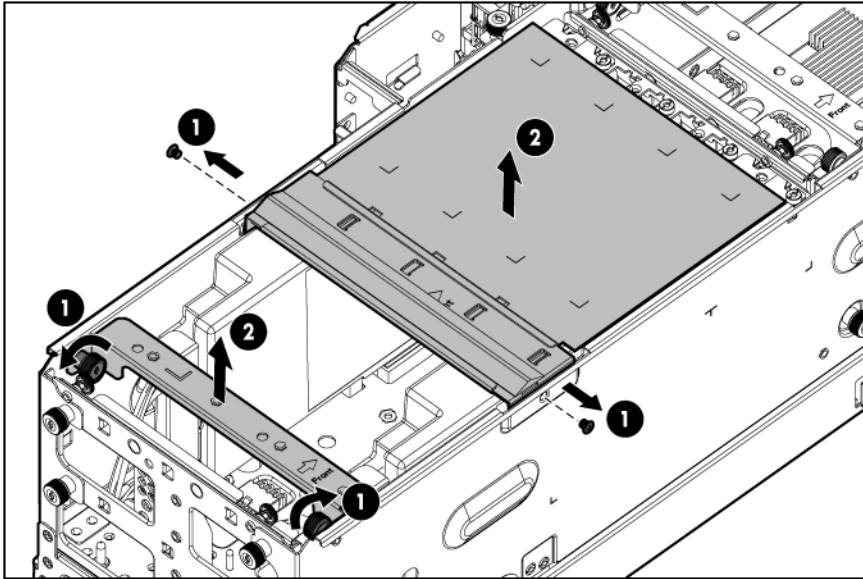

6. Remove the GPU shelf ("GPU shelf" on page 35).
7. Remove the air baffle.

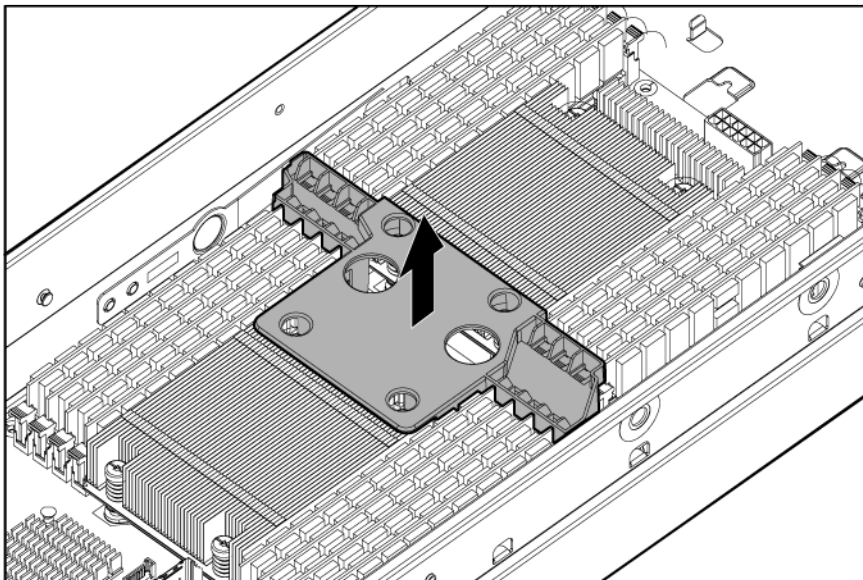

To replace the component, reverse the removal procedure.

## DIMMs

To remove the component:

1. Power down the server (on page 27).
2. Disconnect all peripheral cables from the server.
3. Remove the server from the chassis (on page 27).

4. Remove the hot-plug drive cage ("[Hot-plug drive cage](#)" on page 29).
5. Remove all shipping brackets.

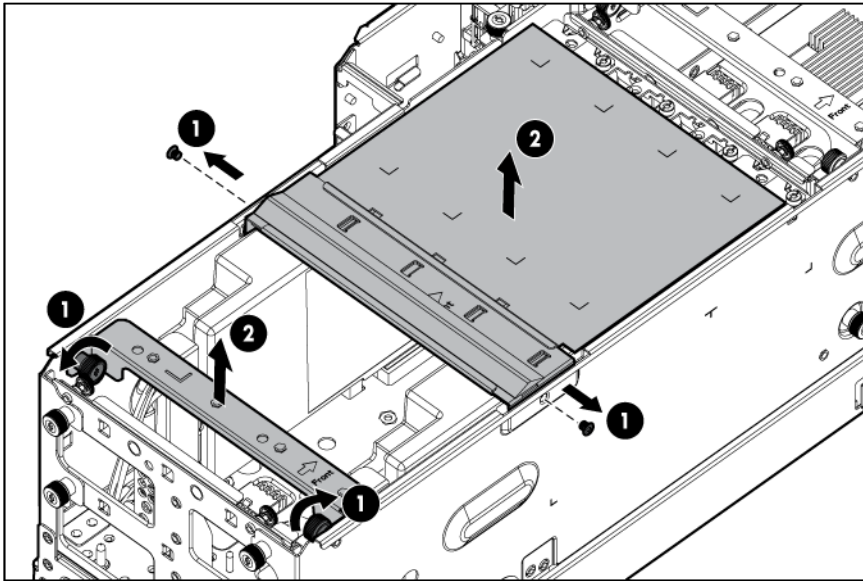

6. Remove the GPU shelf ("[GPU shelf](#)" on page 35).
7. Remove the processor air baffle ("[Processor air baffle](#)" on page 40).
8. Remove the DIMM.

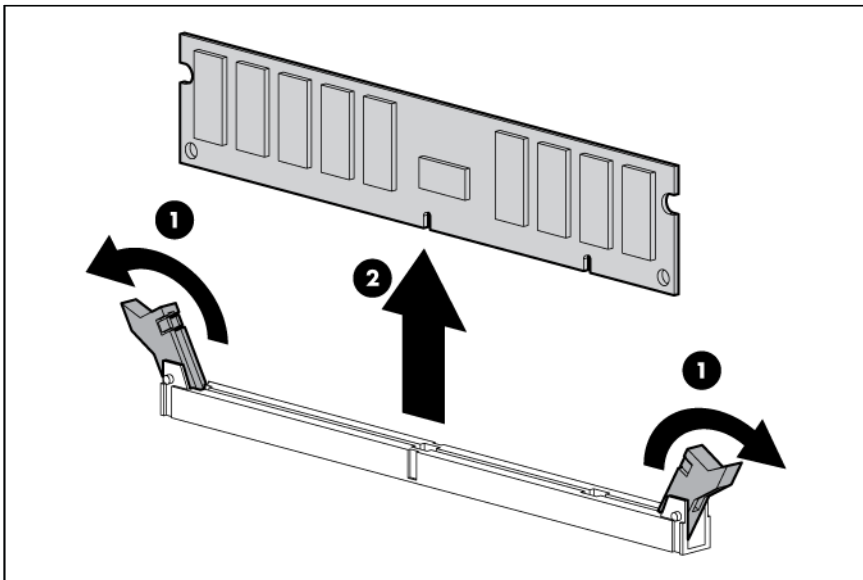

To replace the component, reverse the removal procedure.

## Heatsink

To remove the component:



**CAUTION:** The heatsink thermal interface media is not reusable and must be replaced if the heatsink is removed from the processor after it has been installed.

**CAUTION:** Heatsinks specified for processor 1 and 2 are not interchangeable. Be sure to note the appropriate orientation on the heatsink label.

1. Power down the server (on page 27).
2. Disconnect all peripheral cables from the server.
3. Remove the server from the chassis (on page 27).
4. Remove the hot-plug drive cage ("Hot-plug drive cage" on page 29).
5. Remove all shipping brackets.

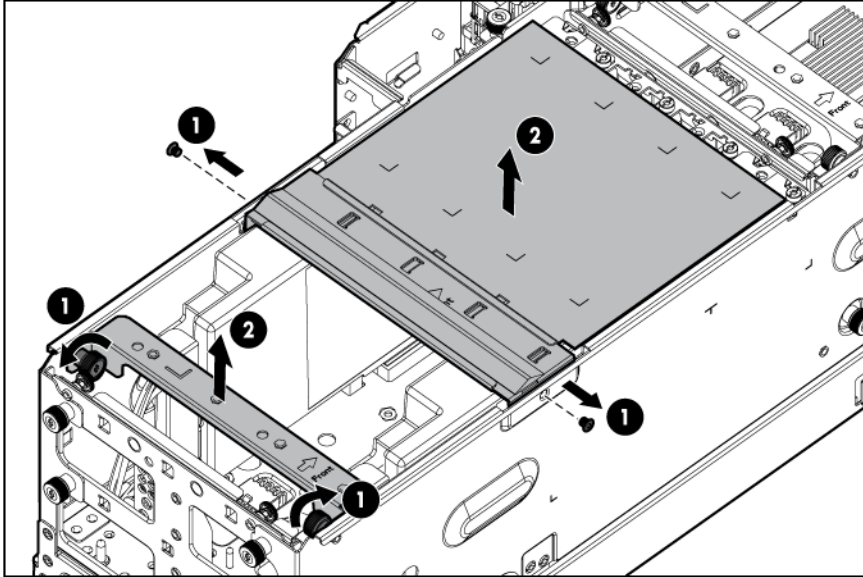

6. Remove the GPU shelf ("GPU shelf" on page 35).
7. Remove the heatsink.

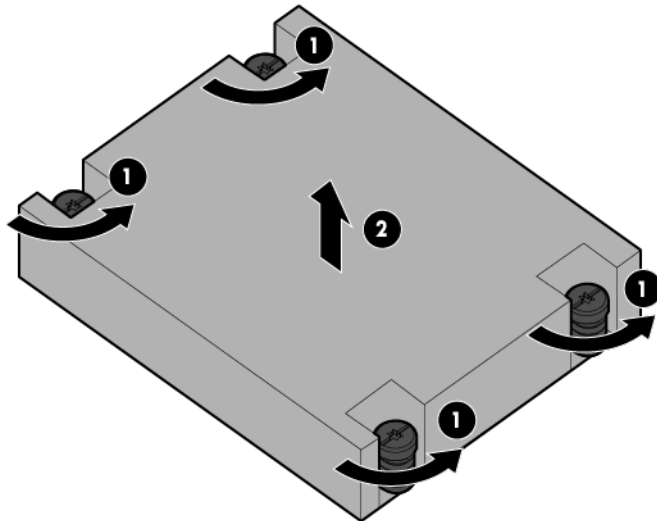

To replace the component:

1. Remove the thermal interface protective cover from the heatsink.

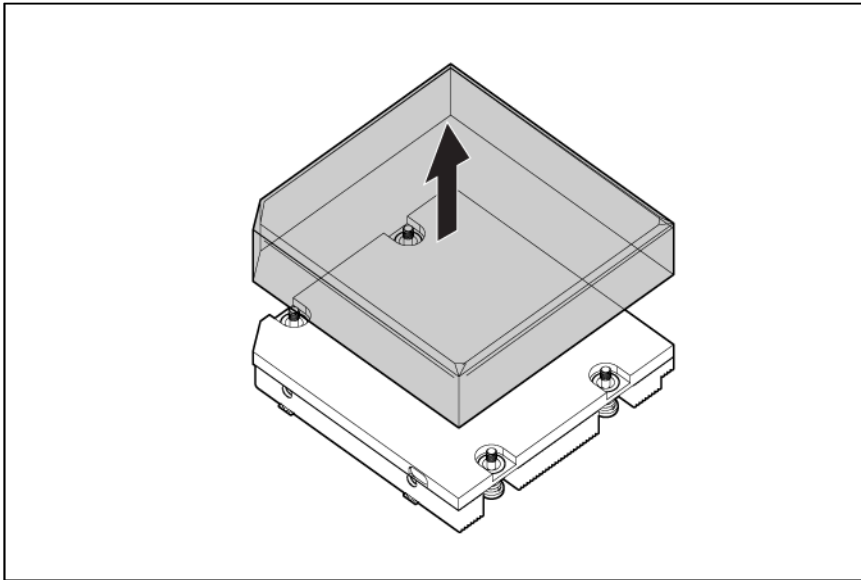

**CAUTION:** Heatsink retaining screws should be tightened in diagonally opposite pairs (in an "X" pattern).

2. Install the heatsink.

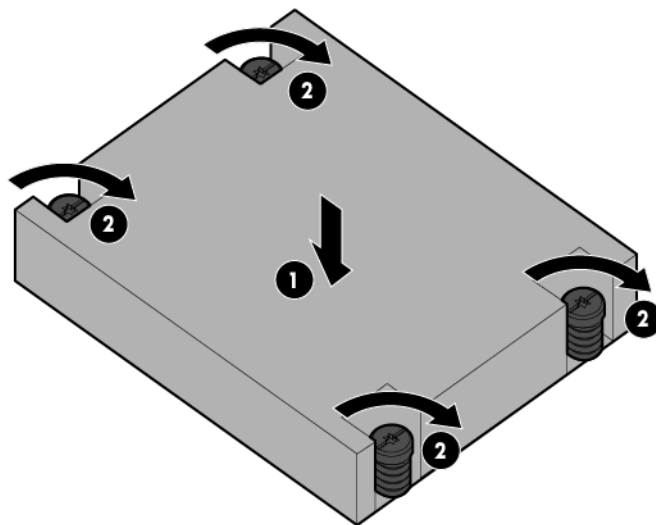

3. Install the processor air baffle.
4. Install the GPU shelf.
5. Install shipping brackets.
6. Install the hard drive cage.
7. Install the server into the chassis.
8. Power up the server.

# Processor

- 
- ⚠ WARNING:** To reduce the risk of personal injury from hot surfaces, allow the drives and the internal system components to cool before touching them.
- 
- ⚠ CAUTION:** To prevent possible server malfunction and damage to the equipment, multiprocessor configurations must contain processors with the same part number.
- 
- ⚠ CAUTION:** Heatsinks specified for processor 1 and 2 are not interchangeable. Be sure to note the appropriate orientation on the heatsink label.
- 
- ⚠ CAUTION:** To prevent possible server overheating, always populate processor socket 2 with a processor and a heatsink or a processor socket cover and a heatsink blank.
- 
- 📝 IMPORTANT:** Processor socket 1 must be populated at all times or the server does not function.
- 
- 📝 IMPORTANT:** The heatsink is not reusable. Install a new heatsink with a thermal pad.
- 

To remove the component:

1. Power down the server (on page [27](#)).
2. Disconnect all peripheral cables from the server.
3. Remove the server from the chassis (on page [27](#)).
4. Remove the hot-plug drive cage ("[Hot-plug drive cage](#)" on page [29](#)).
5. Remove all shipping brackets.

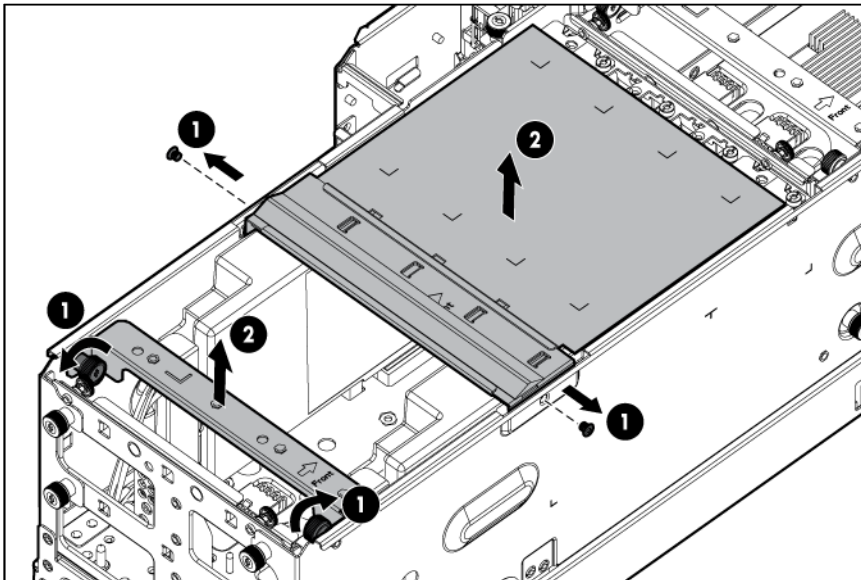

6. Remove the GPU shelf ("[GPU shelf](#)" on page [35](#)).
7. Remove the processor air baffle ("[Processor air baffle](#)" on page [40](#)).
8. Remove the heatsink ("[Heatsink](#)" on page [42](#)).

9. Open each of the processor locking levers in the order indicated, and then open the processor retaining bracket.

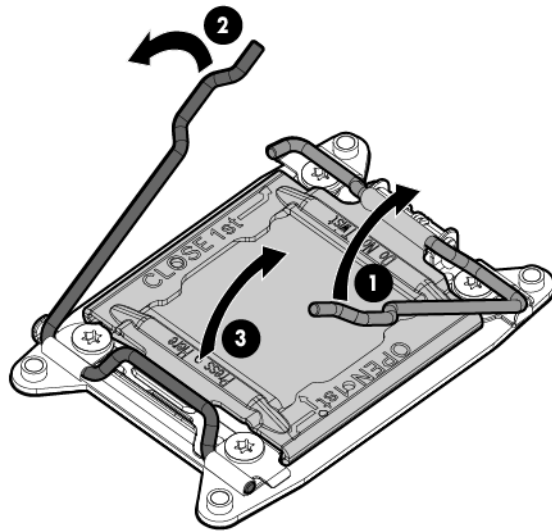

10. Remove the processor from the processor retaining bracket.

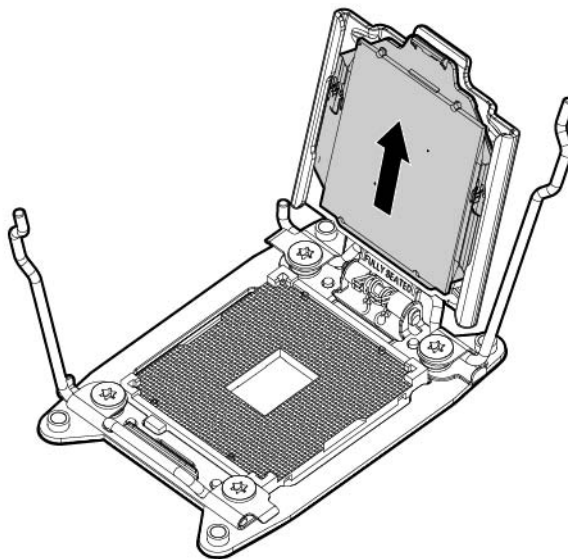

**CAUTION:** To avoid damage to the processor, do not touch the bottom of the processor, especially the contact area.



To install the processor:

1. Install the processor. Verify that the processor is fully seated in the processor retaining bracket by visually inspecting the processor installation guides on either side of the processor. **THE PINS ON THE SYSTEM BOARD ARE VERY FRAGILE AND EASILY DAMAGED.**

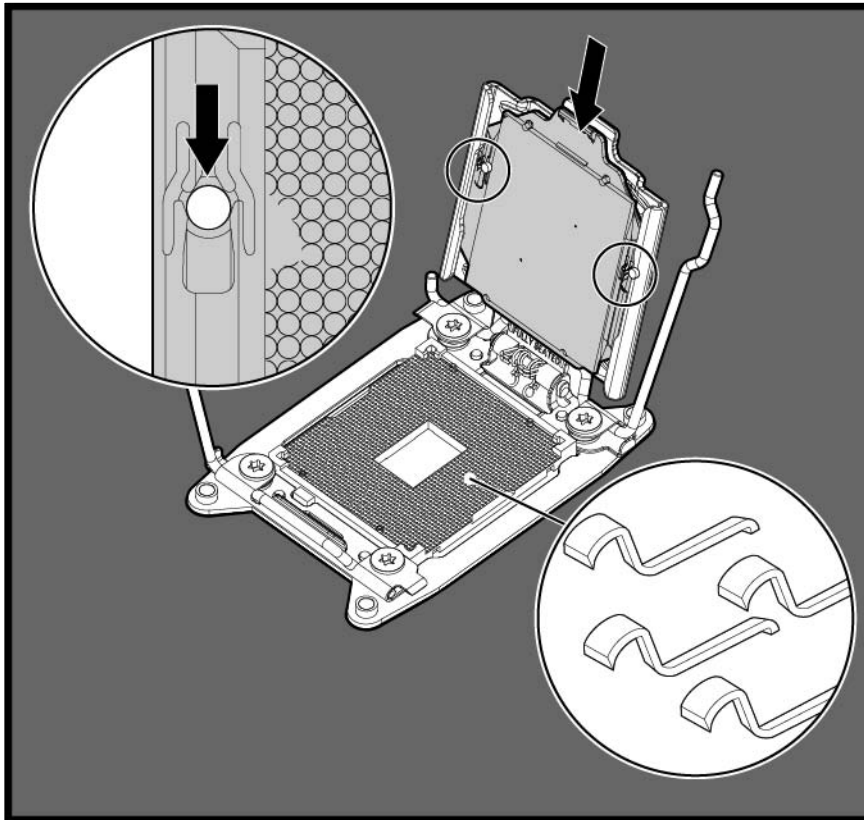

---

△ **CAUTION:** THE PINS ON THE SYSTEM BOARD ARE VERY FRAGILE AND EASILY DAMAGED. To avoid damage to the system board, do not touch the processor or the processor socket contacts.

---

2. Close the processor retaining bracket. When the processor is installed properly inside the processor retaining bracket, the processor retaining bracket clears the flange on the front of the socket.

△ **CAUTION:** Do not press down on the processor. Pressing down on the processor may cause damage to the processor socket and the system board. Press only in the area indicated on the processor retaining bracket.

---

3. Press and hold the processor retaining bracket in place, and then close each processor locking lever. Press only in the area indicated on the processor retaining bracket.

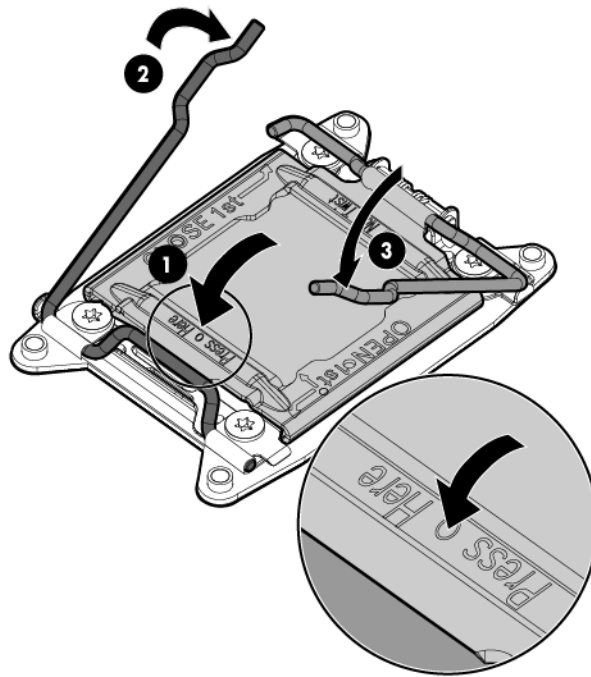

**CAUTION:** Heatsink retaining screws should be tightened in diagonally opposite pairs (in an "X" pattern).

4. Install the new heatsink with thermal pad.

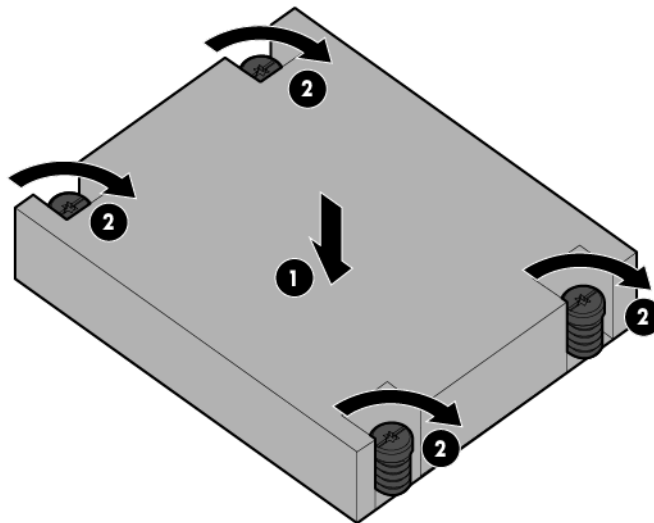

5. Install the processor air baffle.
6. Install the GPU shelf.
7. Install shipping brackets.
8. Install the drive cage.
9. Install the server into the chassis.



10. Power up the server.

## System battery

If the server no longer automatically displays the correct date and time, you might have to replace the battery that provides power to the real-time clock. Under normal use, battery life is 5 to 10 years.

**⚠ WARNING:** The computer contains an internal lithium manganese dioxide, a vanadium pentoxide, or an alkaline battery pack. A risk of fire and burns exists if the battery pack is not properly handled. To reduce the risk of personal injury:

- Do not attempt to recharge the battery.
- Do not expose the battery to temperatures higher than 60°C (140°F).
- Do not disassemble, crush, puncture, short external contacts, or dispose of in fire or water.
- Replace only with the spare designated for this product.

To remove the component:

1. Power down the server (on page 27).
2. Disconnect all peripheral cables from the server.
3. Remove the server from the chassis (on page 27).
4. Remove the hot-plug drive cage ("Hot-plug drive cage" on page 29).
5. Remove all shipping brackets.

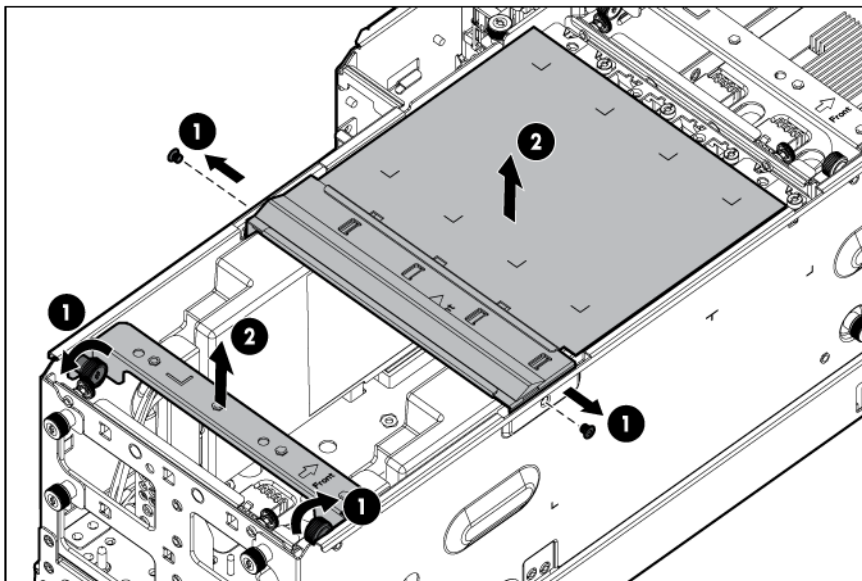

6. Remove the GPU shelf ("GPU shelf" on page 35).
7. Locate the battery on the system board ("System board components" on page 62).

8. Remove the battery.

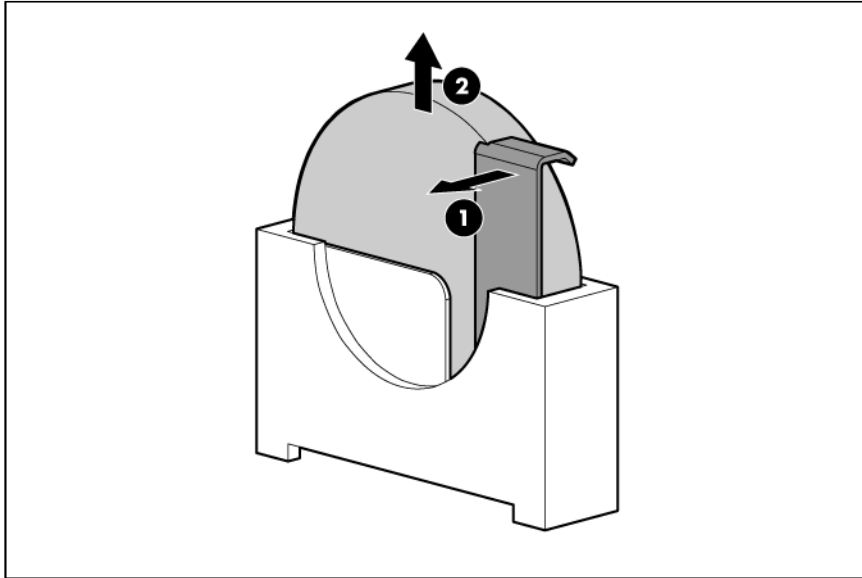

**IMPORTANT:** Replacing the system board battery resets the system ROM to its default configuration. After replacing the battery, reconfigure the system through RBSU.

To replace the component, reverse the removal procedure.

For more information about battery replacement or proper disposal, contact an authorized reseller or an authorized service provider.

## System board

To remove the component:

1. Power down the server (on page 27).
2. Disconnect all peripheral cables from the server.
3. Remove the server from the chassis (on page 27).
4. Remove the hot-plug drive cage ("Hot-plug drive cage" on page 29).

5. Remove all shipping brackets.

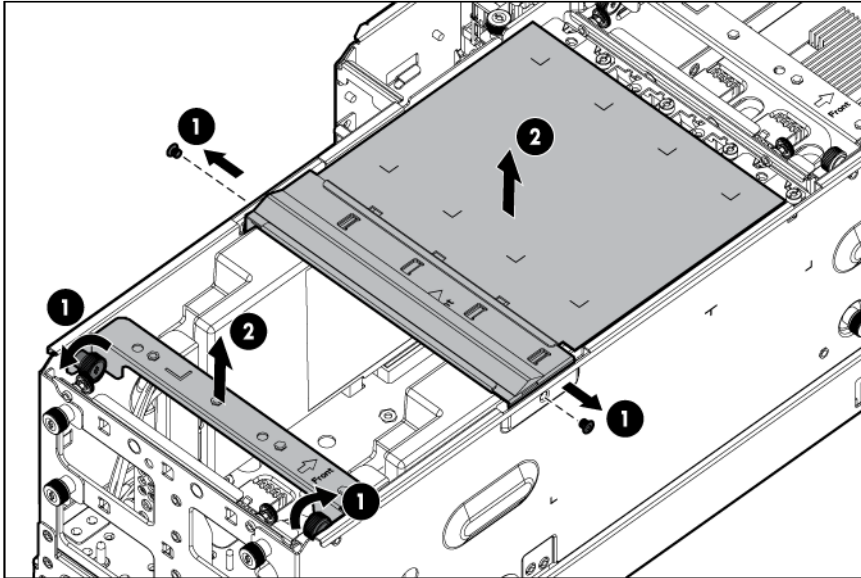

6. Remove the GPU shelf ("GPU shelf" on page 35).
7. Disconnect all cables connected to the system board (on page 50, "System board components" on page 62).
8. Remove all DIMMs ("DIMMs" on page 41).
9. Remove the heatsink ("Heatsink" on page 42).
10. Remove the processor ("Processor" on page 45).
11. Remove the failed system board.

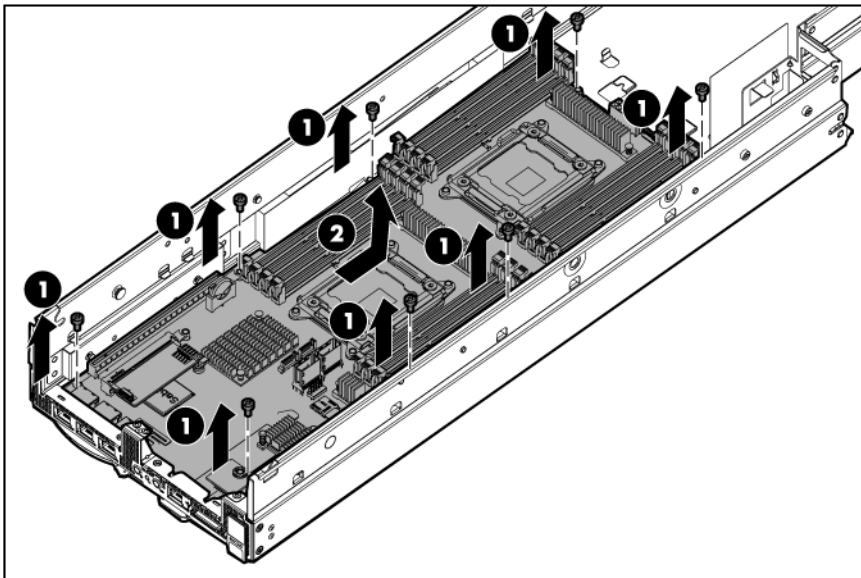

To replace the system board:

1. Align the system board on the tray, and then tighten the thumbscrews to secure it.

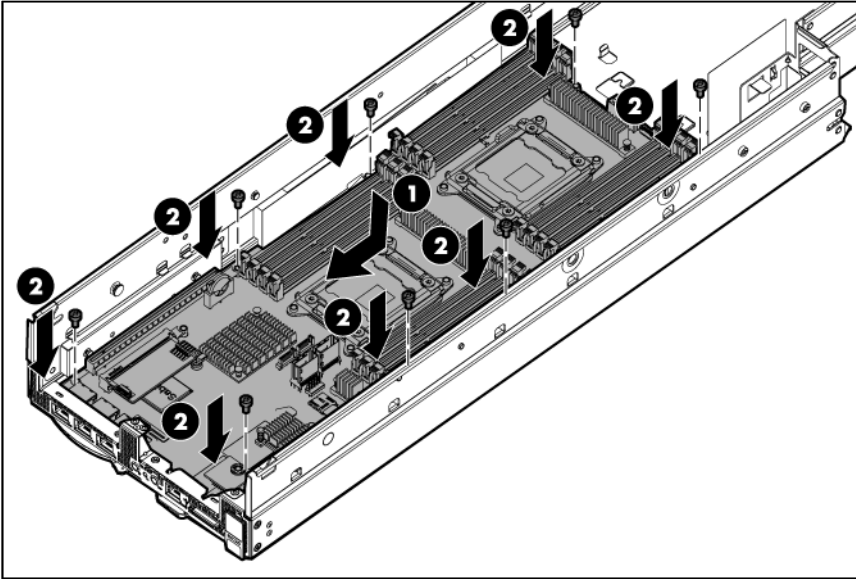

2. Open each of the processor locking levers in the order indicated, and then open the processor retaining bracket.

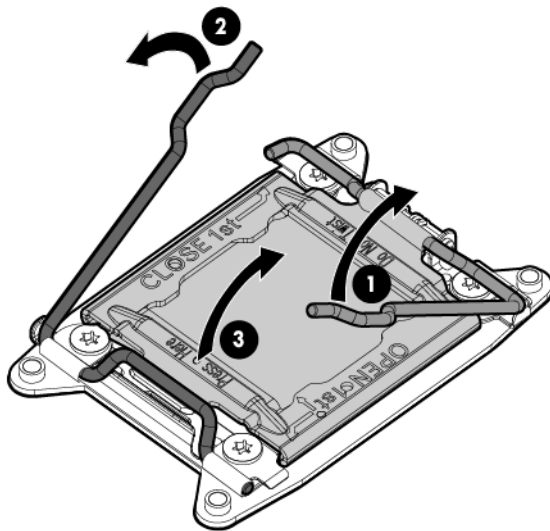

3. Install the processors.
4. Install the heatsinks.
5. Install DIMMs.
6. Connect cables to the system board.
7. Install the GPU shelf.
8. Install shipping brackets.
9. Install the drive cage.
10. Install the server into the chassis.
11. Power up the server.

After you replace the system board, you must re-enter the server serial number and the product ID.

1. During the server startup sequence, press the **F9** key to access RBSU.
2. Select the **Advanced Options** menu.
3. Select **Service Options**.
4. Select **Serial Number**. The following warnings appear:  
WARNING! WARNING! WARNING! The serial number is loaded into the system during the manufacturing process and should NOT be modified. This option should only be used by qualified service personnel. This value should always match the serial number sticker located on the chassis.  
Warning: The serial number should ONLY be modified by qualified service personnel. This value should always match the serial number located on the chassis.
5. Press the **Enter** key to clear the warning.
6. Enter the serial number and press the **Enter** key.
7. Select **Product ID**. The following warning appears:  
Warning: The Product ID should ONLY be modified by qualified service personnel. This value should always match the Product ID on the chassis.
8. Enter the product ID and press the **Enter** key.
9. Press the **Esc** key to close the menu.
10. Press the **Esc** key to exit RBSU.
11. Press the **F10** key to confirm exiting RBSU. The server automatically reboots.

## Power module

To remove the component:

1. Power down the server (on page [27](#)).
2. Disconnect all peripheral cables from the server.
3. Remove the server from the chassis (on page [27](#)).
4. Remove the two screws securing the power module to the system tray.

5. Disconnect the power module from the bus bar connector, and slide the power module out of the rear opening of the system tray.

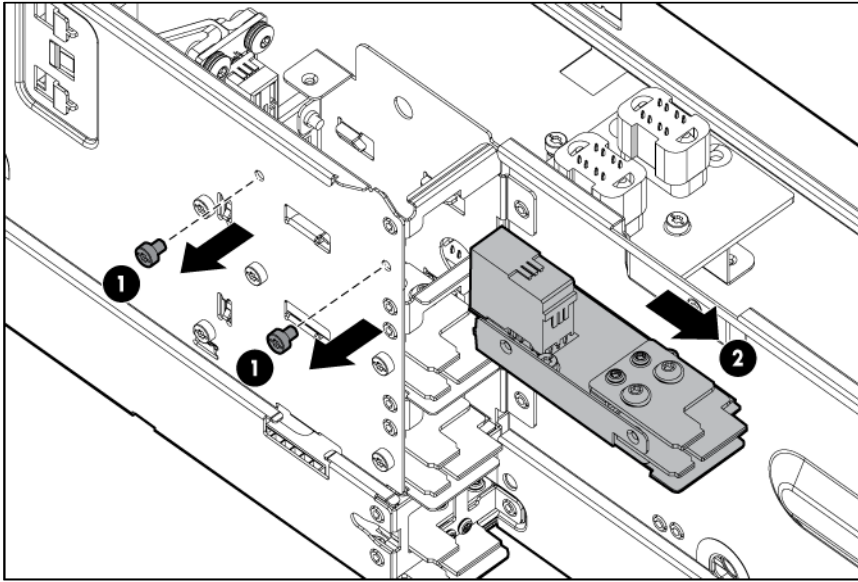

To replace the component, reverse the removal procedure.

## Personality board

To remove the component:

1. Power down the server (on page 27).
2. Disconnect all peripheral cables from the server.
3. Remove the server from the chassis (on page 27).
4. Remove the hot-plug drive cage ("Hot-plug drive cage" on page 29).
5. Remove all shipping brackets.

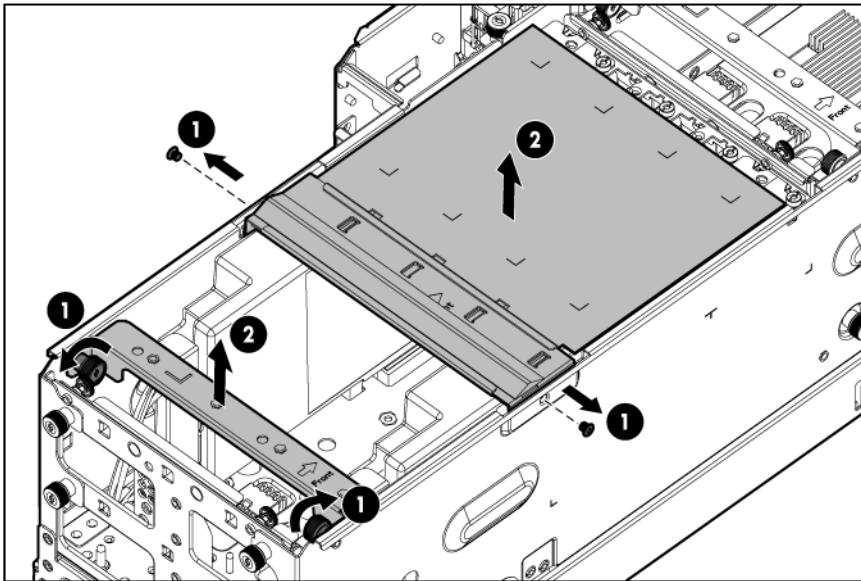

6. Remove the GPU shelf ("GPU shelf" on page 35).



7. Disconnect all cables connected to the personality board.
8. Remove the failed personality board.

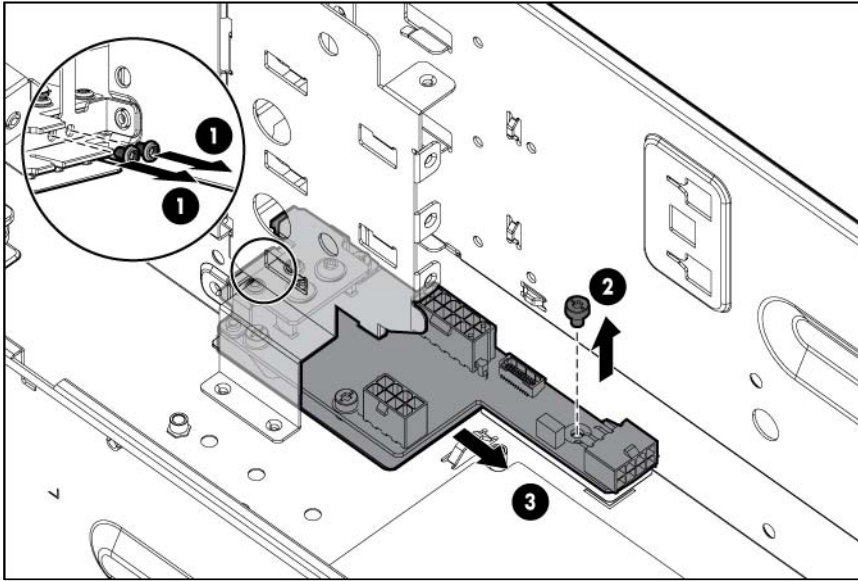

To replace the component, reverse the removal procedure.

## Power interface board and bus bar

To remove the component:

1. Power down the server (on page 27).
2. Disconnect all peripheral cables from the server.
3. Remove the server from the chassis (on page 27).
4. Remove the hot-plug drive cage ("Hot-plug drive cage" on page 29).
5. Remove all shipping brackets.

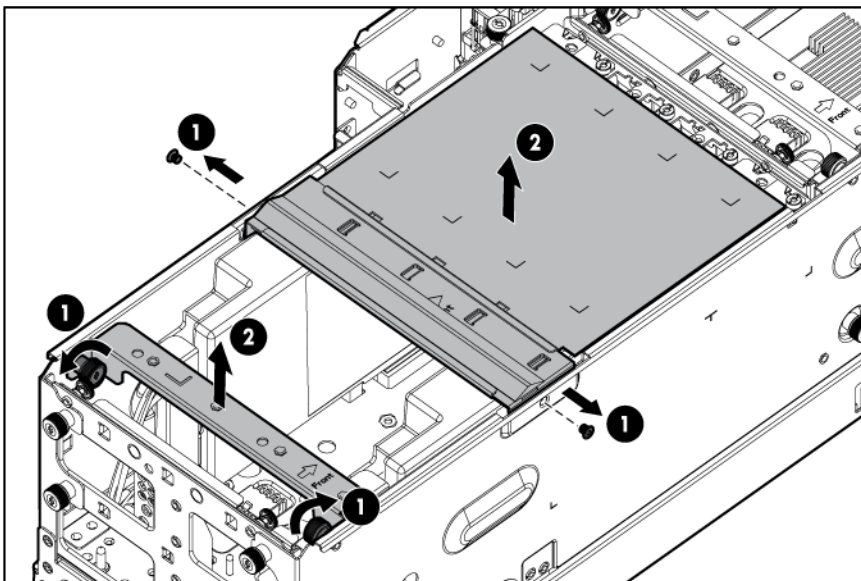

6. Remove the GPU shelf ("GPU shelf" on page 35).

7. Remove any DIMMs adjacent to the bus bar.
8. Remove the screws securing the bus bar to the server tray.
9. Remove the screws securing the power interface board to the bottom of the server tray.
10. Remove the screws securing the bus bar to the power module cage.
11. Remove the bus bar/power interface board assembly:
  - a. Slide the assembly back to disconnect it from the power module connectors.
  - b. Slide the assembly up from behind the power module cage out of the tray.

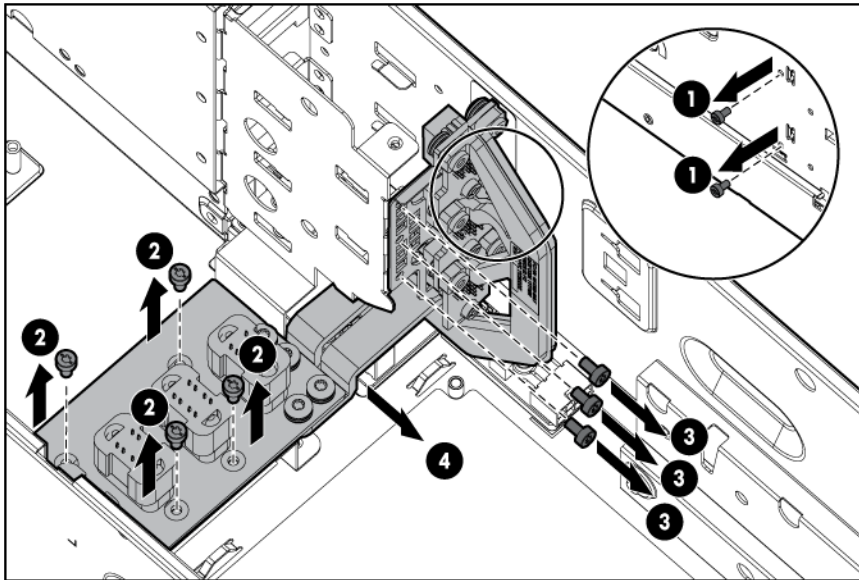

To replace the component, reverse the removal procedure.

## HP Trusted Platform Module

The TPM is not a customer-removable part.

- ⚠ **CAUTION:** Any attempt to remove an installed TPM from the system board breaks or disfigures the TPM security rivet. Upon locating a broken or disfigured rivet on an installed TPM, administrators should consider the system compromised and take appropriate measures to ensure the integrity of the system data.

If you suspect a TPM board failure, leave the TPM installed and remove the system board ("[System board](#)" on page [50](#)). Contact an HP authorized service provider for a replacement system board and TPM board.



---

# Diagnostic tools

## Troubleshooting resources

The *HP ProLiant Gen8 Troubleshooting Guide, Volume I: Troubleshooting* provides procedures for resolving common problems and comprehensive courses of action for fault isolation and identification, issue resolution, and software maintenance on ProLiant servers and server blades. To view the guide, select a language:

- English ([http://www.hp.com/support/ProLiant\\_TSG\\_v1\\_en](http://www.hp.com/support/ProLiant_TSG_v1_en))
- French ([http://www.hp.com/support/ProLiant\\_TSG\\_v1\\_fr](http://www.hp.com/support/ProLiant_TSG_v1_fr))
- Spanish ([http://www.hp.com/support/ProLiant\\_TSG\\_v1\\_sp](http://www.hp.com/support/ProLiant_TSG_v1_sp))
- German ([http://www.hp.com/support/ProLiant\\_TSG\\_v1\\_gr](http://www.hp.com/support/ProLiant_TSG_v1_gr))
- Japanese ([http://www.hp.com/support/ProLiant\\_TSG\\_v1\\_jp](http://www.hp.com/support/ProLiant_TSG_v1_jp))
- Simplified Chinese ([http://www.hp.com/support/ProLiant\\_TSG\\_v1\\_sc](http://www.hp.com/support/ProLiant_TSG_v1_sc))

The *HP ProLiant Gen8 Troubleshooting Guide, Volume II: Error Messages* provides a list of error messages and information to assist with interpreting and resolving error messages on ProLiant servers and server blades. To view the guide, select a language:

- English ([http://www.hp.com/support/ProLiant\\_EMG\\_v1\\_en](http://www.hp.com/support/ProLiant_EMG_v1_en))
- French ([http://www.hp.com/support/ProLiant\\_EMG\\_v1\\_fr](http://www.hp.com/support/ProLiant_EMG_v1_fr))
- Spanish ([http://www.hp.com/support/ProLiant\\_EMG\\_v1\\_sp](http://www.hp.com/support/ProLiant_EMG_v1_sp))
- German ([http://www.hp.com/support/ProLiant\\_EMG\\_v1\\_gr](http://www.hp.com/support/ProLiant_EMG_v1_gr))
- Japanese ([http://www.hp.com/support/ProLiant\\_EMG\\_v1\\_jp](http://www.hp.com/support/ProLiant_EMG_v1_jp))
- Simplified Chinese ([http://www.hp.com/support/ProLiant\\_EMG\\_v1\\_sc](http://www.hp.com/support/ProLiant_EMG_v1_sc))

## HP ROM-Based Setup Utility

RBSU is a configuration utility embedded in ProLiant servers that performs a wide range of configuration activities that can include the following:

- Configuring system devices and installed options
- Enabling and disabling system features
- Displaying system information
- Selecting the primary boot controller
- Configuring memory options
- Language selection

For more information on RBSU, see the *HP ROM-Based Setup Utility User Guide* on the Documentation CD or the HP website (<http://www.hp.com/support/rbsu>).

# HP Insight Diagnostics

HP Insight Diagnostics is a proactive server management tool, available in both offline and online versions, that provides diagnostics and troubleshooting capabilities to assist IT administrators who verify server installations, troubleshoot problems, and perform repair validation.

HP Insight Diagnostics Offline Edition performs various in-depth system and component testing while the OS is not running. To run this utility, boot the server using Intelligent Provisioning.

HP Insight Diagnostics Online Edition is a web-based application that captures system configuration and other related data needed for effective server management. Available in Microsoft Windows and Linux versions, the utility helps to ensure proper system operation.

For more information or to download the utility, see the HP website (<http://www.hp.com/servers/diags>). HP Insight Diagnostics Online Edition is also available in the SPP. For more information, see the HP website (<http://www.hp.com/go/spp/download>).

## Integrated Management Log

The IML records hundreds of events and stores them in an easy-to-view form. The IML timestamps each event with 1-minute granularity.

You can view recorded events in the IML in several ways, including the following:

- From within HP SIM
- From within operating system-specific IML viewers
  - For Windows: IML Viewer
  - For Linux: IML Viewer Application
- From within the iLO 4 user interface
- From within HP Insight Diagnostics (on page 58)

# Component identification

## Front panel components

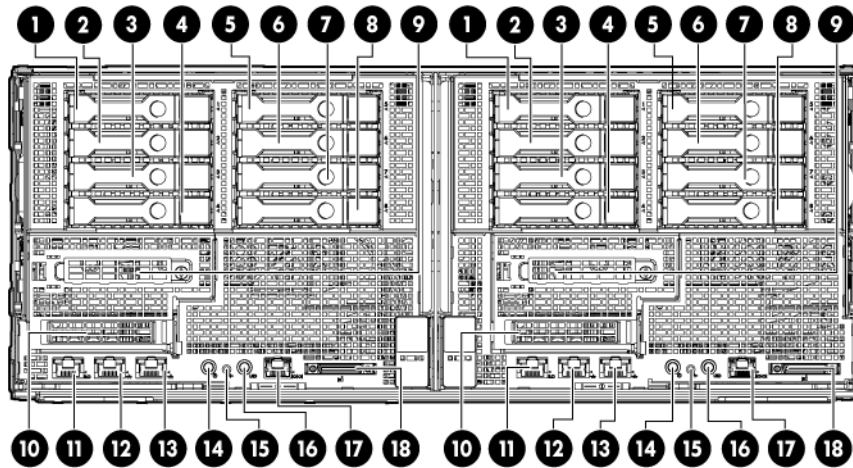

Item	Description
1	Hot-plug hard drive 1
2	Hot-plug hard drive 2
3	Hot-plug hard drive 3
4	Hot-plug hard drive 4
5	Hot-plug hard drive 5
6	Hot-plug hard drive 6
7	Hot-plug hard drive 7
8	Hot-plug hard drive 8
9	Option bay 2, FlexibleLOM
10	Option bay 1, PCI riser board
11	iLO 4 network port
12	NIC 2 network port
13	NIC 1 network port
14	Power On/Standby button and system power LED
15	Health LED
16	UID LED button
17	Serial port
18	SUV port

\* Not shown

# Front panel LEDs and buttons

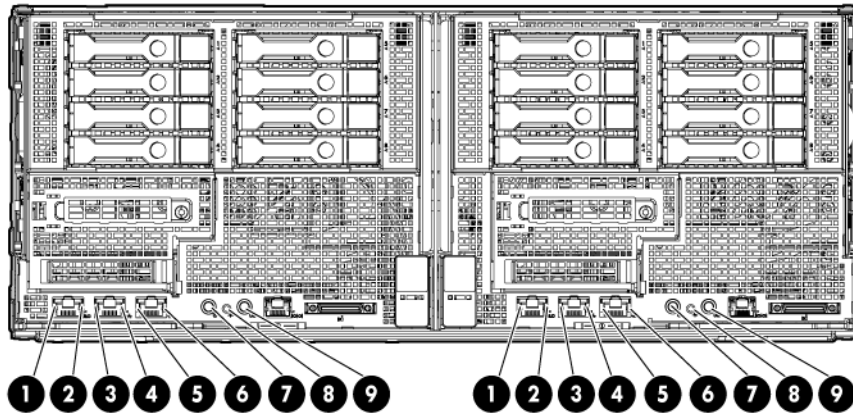

Item	Description	Status
1	iLO 4 network speed LED	Green—LAN connection using a GbE link Amber—LAN connection using a 10 Mbps/100 Mbps link Off—No LAN connection exists.
2	iLO 4 network activity LED	Flashing green—Network data activity exists. Off—No network data activity exists, or no network connection exists.
3	NIC 2 activity LED	Flashing green—Network data activity exists. Off—No network data activity exists, or no network connection exists.
4	NIC 2 speed LED	Green—LAN connection using a GbE link Amber—LAN connection using a 10 Mbps/100 Mbps link Off—No LAN connection exists.
5	NIC 1/iLO 4 activity LED	Flashing green—Network data activity exists. Off—No network data activity exists, or no network connection exists.
6	NIC 1/iLO 4 speed LED	Green—LAN connection using a GbE link Amber—LAN connection using a 10 Mbps/100 Mbps link Off—No LAN connection exists.
7	Power On/Standby button and system power LED	Green—System on Amber—System shut down, but power still applied. Off—Power cord is not attached, or power supply has failed.
8	Health LED	Green—Normal Flashing amber—System degraded Flashing red—System critical
9	UID LED button	Blue—Activated Flashing blue—System is being remotely managed. Off—Deactivated

# Rear panel components

The server has four power supplies, eight fans, and a single SLAPM interface located on the rear panel of the chassis.

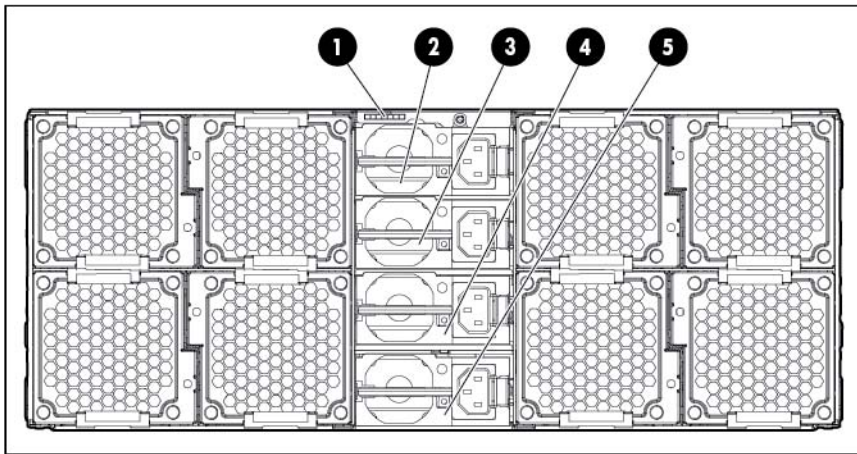

Item	Description
1	SLAPM interface
2	Power supply 4
3	Power supply 3
4	Power supply 2
5	Power supply 1

# Rear panel LEDs and buttons

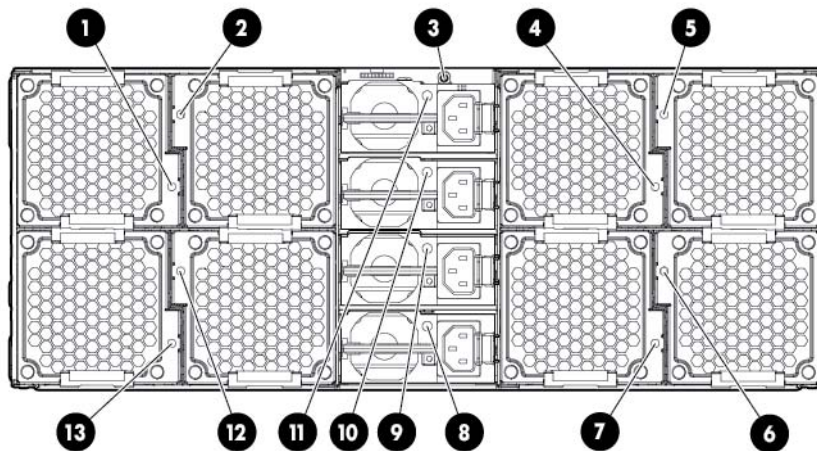

Item	Description	Status
1	Fan 8/16 power LED	Off—Normal Amber—Fan has failed.
2	Fan 7/15 power LED	Off—Normal Amber—Fan has failed.
3	UID LED button	Blue—Activated

Item	Description	Status
		Flashing blue—System is being remotely managed. Off—Deactivated
4	Fan 4/12 power LED	Off—Normal Amber—Fan has failed.
5	Fan 3/11 power LED	Off—Normal Amber—Fan has failed.
6	Fan 1/9 power LED	Off—Normal Amber—Fan has failed.
7	Fan 2/10 power LED	Off—Normal Amber—Fan has failed.
8	Power supply 1 power LED	Green—Normal Off—No AC power
9	Power supply 2 power LED	Green—Normal Off—No AC power
10	Power supply 3 power LED	Green—Normal Off—No AC power
11	Power supply 4 power LED	Green—Normal Off—No AC power
12	Fan 5/13 power LED	Off—Normal Amber—Fan has failed.
13	Fan 6/14 power LED	Off—Normal Amber—Fan has failed.

## System board components

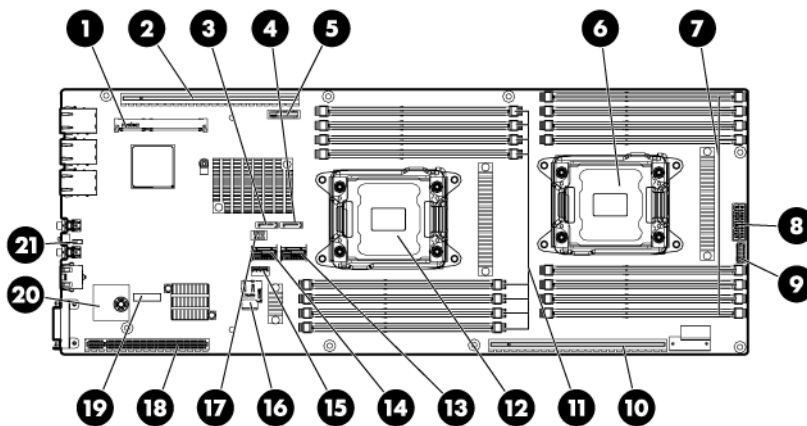

Item	Description
1	Cache module connector
2	x24 riser connector
3	SATA hard drive connector 1

Item	Description
4	SATA hard drive connector 2
5	System battery
6	Processor socket 2
7	Processor 2 DIMM slots
8	Power connector
9	RPS connector
10	x32 riser connector
11	Processor 1 DIMM slots
12	Processor socket 1 (populated)
13	Mini-SAS hard drive connector port 2i
14	Mini-SAS hard drive connector port 1i
15	Internal USB connector
16	uSD card slot
17	Data LED connector
18	x16 FlexibleLOM slot
19	System maintenance switch
20	Trusted Platform Module
21	NMI header

## DIMM slot locations

DIMM slots are numbered sequentially (1 through 8) for each processor. The supported AMP modes use the alpha assignments for population order, and the slot numbers designate the DIMM slot ID for spare replacement.

The arrow points to the front of the server.

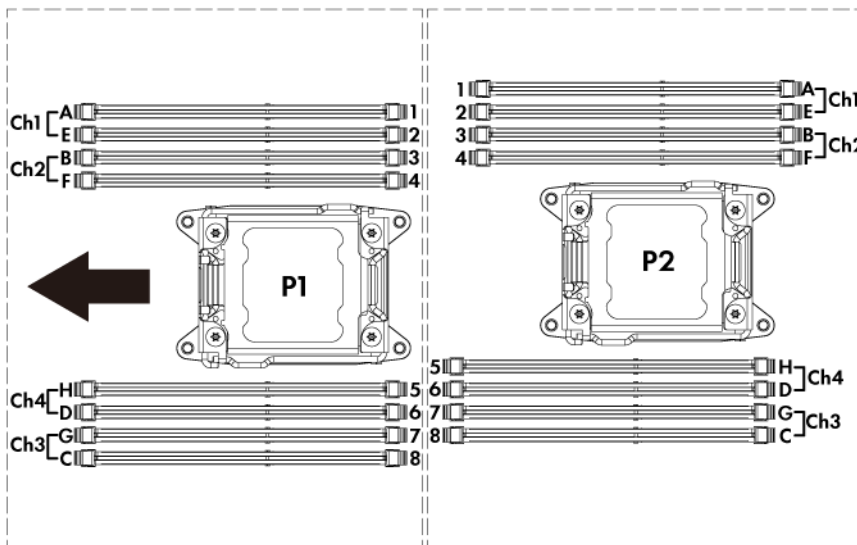

## System maintenance switch

Position	Default	Function
S1	Off	Off = iLO 4 security is enabled. On = iLO 4 security is disabled.
S2	Off	Off = System configuration can be changed. On = System configuration is locked.
S3	Off	Reserved
S4	Off	Reserved
S5	Off	Off = Power-on password is enabled. On = Power-on password is disabled.
S6	Off	Off = No function On = ROM reads system configuration as invalid.
S7	—	Reserved
S8	—	Reserved
S9	—	Reserved
S10	—	Reserved
S11	—	Reserved
S12	—	Reserved

To access redundant ROM, set S1, S5, and S6 to on.

When the system maintenance switch position 6 is set to the On position, the system is prepared to erase all system configuration settings from both CMOS and NVRAM.

 **CAUTION:** Clearing CMOS and/or NVRAM deletes configuration information. Be sure to properly configure the server or data loss could occur.

## NMI header

The NMI header enables administrators to perform a memory dump before performing a hard reset. Crash dump analysis is an essential part of eliminating reliability issues, such as hangs or crashes in operating systems, device drivers, and applications. Many crashes can freeze a system, requiring you to perform a hard reset. Resetting the system erases any information that supports root cause analysis.

When a Windows® operating system crashes, a blue-screen trap appears. When this trap appears, Microsoft® recommends that system administrators perform an NMI event by temporarily shorting the NMI header with a jumper. The NMI event enables a hung system to become responsive again.

For additional information, see the HP website

(<http://h20000.www2.hp.com/bc/docs/support/SupportManual/c00797875/c00797875.pdf>).



# Device numbers

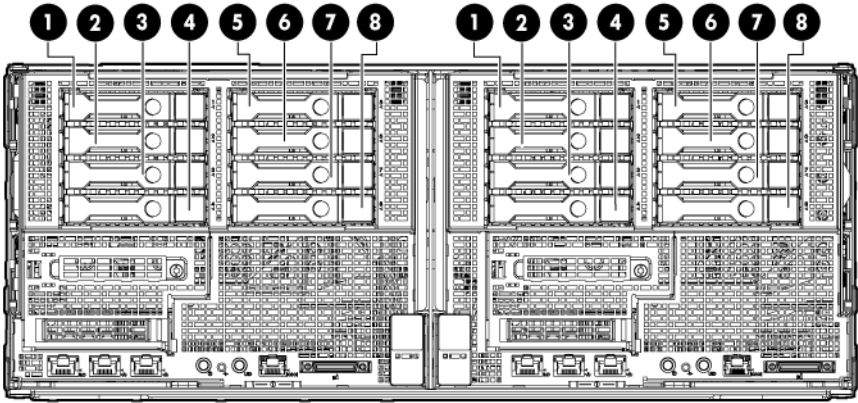

Item	Description
1	Hard drive 1
2	Hard drive 2
3	Hard drive 3
4	Hard drive 4
5	Hard drive 5
6	Hard drive 6
7	Hard drive 7
8	Hard drive 8

# Drive LED definitions

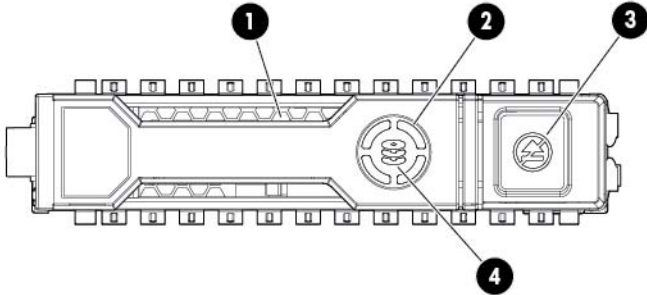

Item	LED	Status	Definition
1	Locate	Solid blue	The drive is being identified by a host application.
		Flashing blue	The drive carrier firmware is being updated or requires an update.
2	Activity ring	Rotating green	Drive activity
		Off	No drive activity

<b>Item</b>	<b>LED</b>	<b>Status</b>	<b>Definition</b>
3	Do not remove	Solid white	Do not remove the drive. Removing the drive causes one or more of the logical drives to fail.
		Off	Removing the drive does not cause a logical drive to fail.
4	Drive status	Solid green	The drive is a member of one or more logical drives.
		Flashing green	The drive is rebuilding or performing a RAID migration, stripe size migration, capacity expansion, or logical drive extension, or is erasing.
		Flashing amber/green	The drive is a member of one or more logical drives and predicts the drive will fail.
		Flashing amber	The drive is not configured and predicts the drive will fail.
		Solid amber	The drive has failed.
		Off	The drive is not configured by a RAID controller.

---

# Cabling

## Cabling overview

This section provides guidelines that help you make informed decisions about cabling the server and hardware options to optimize performance.

For information on cabling peripheral components, refer to the white paper on high-density deployment at the HP website (<http://www.hp.com/products/servers/platforms>).

**CAUTION:** When routing cables, always be sure that the cables are not in a position where they can be pinched or crimped.

## FBWC capacitor pack cabling

Left node

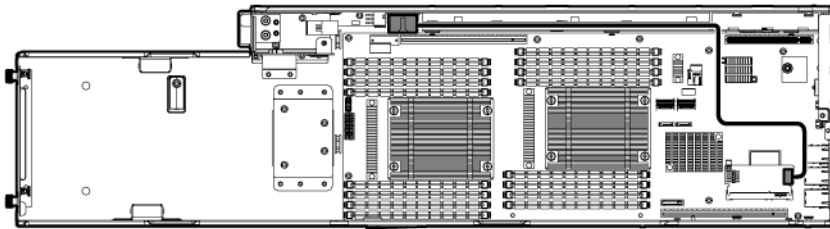

Right node

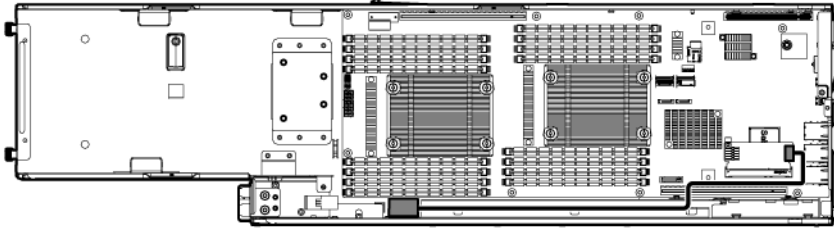

---

# Specifications

## Environmental specifications

Specification	Value
<b>Temperature range*</b>	—
Operating	10°C to 35°C (50°F to 95°F)
Shipping	-40°C to 70°C (-40°F to 158°F)
Maximum wet bulb temperature	28°C (82.4°F)
130 W CPU option	10°C to 35°C (50°F to 77°F)
<b>Relative humidity (noncondensing)**</b>	—
Operating	10% to 90%
Nonoperating	5% to 95%

\* All temperature ratings shown are for sea level. An altitude derating of 1°C per 300 m (1.8°F per 1,000 ft) to 3,048 m (10,000 ft) is applicable. No direct sunlight allowed.

\*\* Storage maximum humidity of 95% is based on a maximum temperature of 45°C (113°F). Altitude maximum for storage corresponds to a pressure minimum of 70 kPa.

## Server specifications

Specification	Value
Height	16.82 cm (6.62 in)
Depth	81.91 cm (32.25 in)
Width	22.08 cm (8.69 in)
Weight (maximum: two processors, eight hard drives)	21.32 kg (47.00 lb)

## Hot-plug power supply calculations

For hot-plug power supply specifications and calculators to determine electrical and heat loading for the server, see the HP website (<http://www.hp.com/go/hppoweradvisor>).

---

# Acronyms and abbreviations

## CSR

Customer Self Repair

## FBWC

flash-backed write cache

## IEC

International Electrotechnical Commission

## iLO

Integrated Lights-Out

## IML

Integrated Management Log

## LFF

large form factor

## NMI

nonmaskable interrupt

## NVRAM

nonvolatile memory

## POST

Power-On Self Test

## RBSU

ROM-Based Setup Utility

## SATA

serial ATA

## SFF

small form factor

## SIM

Systems Insight Manager

## TMRA

recommended ambient operating temperature

## UID

unit identification

## USB

universal serial bus

---

# Documentation feedback

HP is committed to providing documentation that meets your needs. To help us improve the documentation, send any errors, suggestions, or comments to Documentation Feedback (<mailto:docsfeedback@hp.com>). Include the document title and part number, version number, or the URL when submitting your feedback.



---

# Index

## A

air baffle 40

## B

battery 49  
bus bar, removing 55  
buttons 59, 60, 61

## C

cables 67  
cabling 67  
cautions 26  
chassis, removing server 27  
components 16, 25, 56, 59  
components, identification 16, 19, 59, 61, 62, 63, 65  
components, system board 62  
connectors 59

## D

device numbers 65  
diagnostic tools 57, 58  
diagnostics utility 58  
DIMMs 41, 63  
drive bays 59, 65  
drive blank 28  
drive LEDs 65  
drive, replacing 28  
drives 28, 65  
drives, determining status of 65  
drives, removing 28, 29

## E

electrostatic discharge 25  
environmental requirements 69  
expansion board 30

## F

FBWC capacitor pack 38, 39  
FBWC capacitor pack holder 39

features 59  
FlexibleLOM 30  
FlexibleLOM riser 31  
front panel components 59  
front panel LEDs 60

## G

GPU blank, removing 34  
GPU module, removing 34, 35  
GPU shelf, removing 35

## H

heatsink 42  
hot-plug hard drive 28  
HP Insight Diagnostics 25, 58

## I

iLO (Integrated Lights-Out) 58  
IML (Integrated Management Log) 58  
Insight Diagnostics 58  
Integrated Management Log (IML) 58

## L

LEDs 59, 60, 61, 65  
LEDs, drive 65  
LEDs, hard drive 65  
LEDs, power supply 61  
LEDs, SAS hard drive 65

## M

management tools 57  
mechanical components 16  
memory 41, 63  
mezzanine assembly 37  
mezzanine boards, removing 37

## N

NMI header 64

## **P**

- PCI riser board 31
- PCI riser board assembly 31
- personality board 54
- power interface board 55
- power module 53
- power requirements 69
- power supply 69
- power supply LEDs 61
- powering down 27
- preparation procedures 26
- processor 45
- processor air baffle 40

## **R**

- RBSU (ROM-Based Setup Utility) 57
- rear panel components 61
- rear panel LEDs 61
- removing server from chassis 27
- requirements, power 69
- riser board 30, 31, 32
- ROM-Based Setup Utility (RBSU) 57

## **S**

- safety considerations 25
- safety information 25
- SAS drives 65
- server, installation 27
- specifications 69
- static electricity 25
- symbols on equipment 25
- system battery 49
- system board components 62
- system board replacement 50
- system components 19, 59
- system maintenance switch 64

## **T**

- TPM (Trusted Platform Module) 56
- troubleshooting 57
- troubleshooting resources 57
- Trusted Platform Module (TPM) 56

## **U**

- UID LED 61
- utilities 57
- utilities, deployment 57

## **W**

- warnings 26

## **X**

- x16/x32 riser board 32
- x32 riser board 32