

A Reference Guide for Optimizing the Dell™ PowerVault™ MD1000 SAS Solution

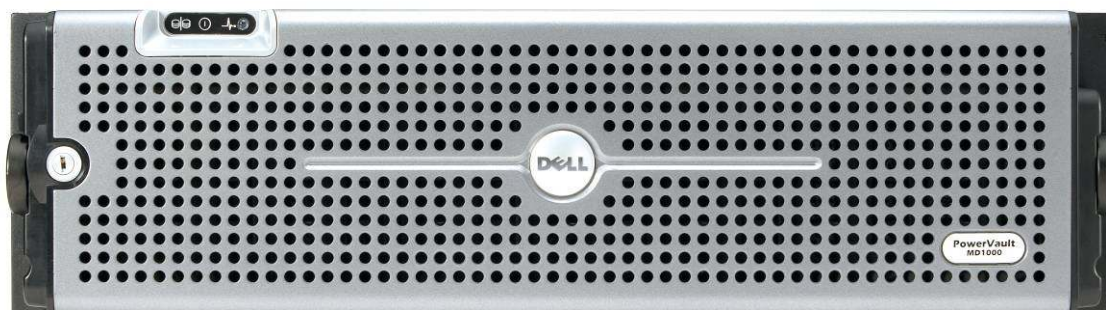

Authored By:
SAS Solution Team

April, 2006 rev A01

THIS WHITE PAPER IS FOR INFORMATION PURPOSES ONLY, AND MAY CONTAIN TYPOGRAPHICAL ERRORS AND TECHNICAL INACCURACIES. THE CONTENT IS PROVIDED AS IS WITHOUT EXPRESS OR IMPLIED WARRANTIES OF ANY KIND.

Information in this document is subject to change without notice.

© Copyright 2006 Dell Inc. All rights reserved.

Reproduction in any manner whatsoever without the written permission of Dell Inc. is strictly forbidden.

Dell, the *Dell* Logo, *PowerVault*, *PowerEdge* and *OpenManage* are trademarks of Dell Inc. *Microsoft* is a registered trademark of Microsoft Corporation. Other trademarks and trade names may be used in this document to refer to either the entities claiming the marks and names or their products. Dell disclaims proprietary interest in the marks and names of others.

TABLE OF CONTENTS

1.	INTRODUCTION	4
	<i>Serial Attached SCSI (SAS)</i>	5
2.	RECOMMENDED MAINTENANCE FOR YOUR DELL POWERVAULT MD1000 SAS SOLUTION	6
3.	DELL'S SAS PRODUCT OFFERING	7
	<i>SAS Cabling</i>	8
	<i>Physical Drive Support</i>	8
	<i>3rd Party Hardware support</i>	9
	<i>Server Support</i>	9
4.	POWERVAULT MD1000 STORAGE ENCLOSURE DETAILS.....	9
	<i>Enclosure Modes</i>	9
	<i>Unified Topology</i>	9
	<i>Split Topology</i>	10
	<i>Daisy-Chaining Multiple PowerVault MD1000 Storage Enclosures</i>	10
	<i>PowerVault MD1000 – Common Features and Capabilities</i>	11
5.	PERC 5/E CONTROLLER - DETAILED FEATURES	15
	<i>Considerations when implementing a RAID Solution</i>	15
	<i>Controller Features</i>	15
	<i>Capacity Requirements</i>	17
6.	DELL OPENMANAGE SERVER ADMINISTRATOR.....	19
	<i>Managing the PERC 5/E Controller and the PowerVault MD1000 Storage Enclosure</i>	19
	<i>Using the Create Virtual Disk Wizards</i>	19
	<i>Reconfiguring Virtual Disks -- RAID Migration and Capacity Expansion</i>	20
	<i>Moving Physical Disks and Virtual Disk Configurations – Disk Roaming and Disk Migration</i>	21
	<i>Importing Migrated Virtual Disks</i>	22
	<i>Upgrading from Dell OpenManage Array Manager</i>	24
7.	STORAGE APPLICATIONS AND COMPONENTS.....	25
	<i>Identify customer usage model and needs</i>	25
	<i>Picking a solution based on the application profile</i>	26
	<i>Application specific guidelines</i>	27
	<i>E-Mail Servers</i>	27
	<i>Web Servers</i>	28
	<i>Database or Online Transaction Processing Servers</i>	29
	<i>File Servers</i>	30
	<i>Streaming Media Servers</i>	32
	<i>Hot Spares</i>	33
8.	SUMMARY AND CONCLUSIONS	33
9.	APPENDIX – A: REFERENCES.....	35
10.	APPENDIX – B: GLOSSARY	35
11.	APPENDIX – D: REVISION HISTORY	35

1. Introduction

A complete enterprise storage solution involves various software and hardware components. A given storage project can be addressed using several approaches. Therefore, it is essential to identify optimum storage solutions for different applications.

Selecting the right storage components not only impacts the effectiveness of a given application but may also improve the performance of the entire IT infrastructure which relies on that storage. See table 1 for examples of key storage components.

Table 1: Examples of the components in a typical storage solution

Storage Solution Components	Examples
Physical Storage Device Technology	Storage Expansion Enclosure (e.g., PowerVault MD1000)
Interconnect Technology	3 Gbps Serial Attached SCSI (SAS)
Host System Interface Technology	Non-RAID (HBA) or RAID controllers (e.g. PowerEdge Expandable Raid Controller)
Management Capabilities	Dell OpenManage Server Administrator

As with many IT solutions, storage deployments can be assessed using numerous criteria, each with varying levels of importance. In general, the effectiveness of a given storage solution should be measured using the following attributes:

- *Reliability* – The solution remains functional and ensures that data is unaltered
- *Availability* – Data remains accessible by the application.
- *Serviceability* – The hardware has easy access to assemblies/components, allowing easy maintenance and replacement.
- *Redundancy* – The hardware provides redundancy for both the data storage, as well as for the hardware management capabilities.
- *Performance*
 - Bandwidth Utilization – Data throughput / available Bandwidth
 - IOPS – I/Os per second
- *Data Protection* – Data is protected against catastrophic system failure or components failure.
- *Scalability* – Storage capacity can be expanded as the application necessitates.
- *Cost* – Measured in total lifetime cost, acquisition cost, or \$ per Gigabyte.

An optimal storage solution addresses all key attributes to a greater or lesser extent depending on their relative importance. This paper presents a study of the technological, functional and behavioral differences of the storage solution components and measures them against the attributes listed above. Understanding each component with respect to these attributes will help in making informed decisions about the optimal solution for a given storage application.

The paper presumes that the reader has a basic understanding of different RAID levels and interconnect technologies – such as Serial Attached SCSI (SAS) and PCI Express. In this paper, we will focus on Serial Attached SCSI storage technology, specifically for Dell's PowerVault MD1000 storage expansion enclosure and Dell's PERC 5/E RAID controller. Other storage technologies such as SCSI or Fibre Channel, as well as topologies such as Network Attached Storage (NAS) or Storage Area Network (SAN) are outside the scope of this document. All storage applications will be treated independent of any specific host system or server.

Serial Attached SCSI (SAS)

The SCSI (Small Computing System Interface) protocol originated more than 20 years ago and is used in the majority of server storage needs (e.g. storage that is internal to a server or physically connected to a server in an external disk expansion enclosure). The market prevalence of SCSI has created economies of scale making it one of the most affordable storage interconnect technologies available today. Many businesses rely on SCSI physical disks to help deliver extremely cost-effective and reliable storage. In fact, SCSI physical disks have advanced over the years offering increased performance and more sophisticated features with each iteration. However, given the inherent limitations of its parallel architecture, the current version of SCSI physical disks, U320 or Ultra320, will be the last version of the traditional SCSI technology.

Serial Attached SCSI (SAS) is a major iteration of SCSI technology and introduces a host of benefits when compared to older SCSI technology including,

Dramatic improvement in bandwidth performance

- The first generation of SAS will support 3.0 Gbps (or 300 MB/sec) per “lane”
- Ultra320 SCSI is the shared-bus architecture. SAS introduces a point to point topology enabling systems with many physical disks to scale bandwidth far beyond the bandwidth capacity of Ultra320 SCSI.

Figure 1: Parallel U320 SCSI bus versus point to point Serial Attached SCSI connection

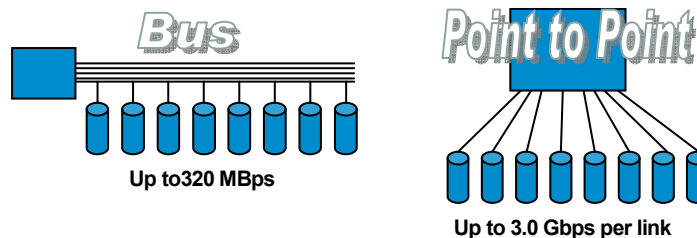

- SAS introduces the concept of port aggregation to storage interconnects. External storage devices can connect via a x4 (“by four”) wide-lane. Cabling aggregates four SAS lanes, each operating at 3.0 Gbps, for a full external connection bandwidth of up to 12.0 Gbps on a single connector.

Figure 2: Bandwidth improvement with SAS port aggregation

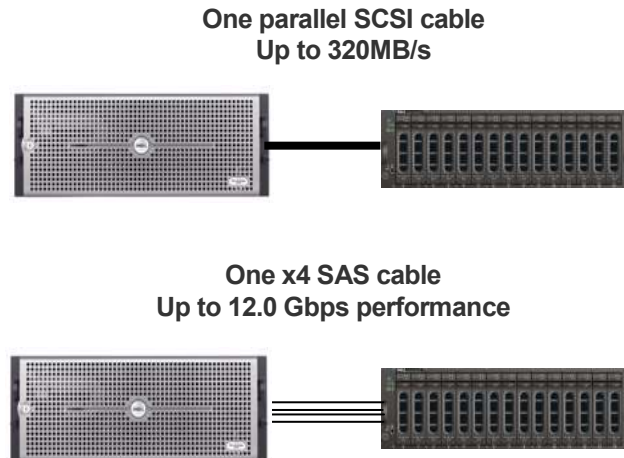

Improved capacity scalability

- SAS allows for port expansion, enabling the ability to “daisy-chain” storage enclosures for dramatic improvements in capacity scalability. With Ultra320 SCSI, systems were limited to a maximum of 16 devices on a single SCSI channel. This typically translated to maximum of 14 physical disks connected to a single SCSI channel on a RAID controller. With SAS expansion, a single SAS port can be expanded out to multiple SAS devices (similar to how Ethernet hubs can expand a single Ethernet connection into multiple devices).

Other important changes to keep in mind about SAS:

- SAS continues to use the SCSI command sets for driver & software compatibility.
- SAS is not backwards compatible with Parallel SCSI.

2. Recommended Maintenance for your Dell PowerVault MD1000 SAS Solution

Dell strives to provide the best possible customer experience for all of our enterprise server and storage products. Proper maintenance of your solution is essential to help ensure that the equipment remains in optimal working condition. Dell recommends the following suggested maintenance activities.

Keep firmware/drivers/utilities up to date

In general, Dell posts planned maintenance updates for firmware twice a year. To stay current with the latest updates, customers can subscribe to Dell notification tools. Click the following link to sign up for technical updates.

<http://support.dell.com/support/topics/global.aspx/support/notifications/en/index?c=us&l=en&s=gen>

Enable Background Read Patrol

Background Read Patrol, a function of the RAID controller, is an automatically scheduled background task that scans and helps resolve possible physical disk errors that may lead to physical disk failure and result in data integrity issues. Dell recommends implementing Background Read Patrol in all configurations.

See section 5 for details.

Schedule and run periodic consistency checks / Background Initialization (BGI)

Consistency checks / BGI are performed by many RAID controllers to verify that all stripes in a redundant virtual disk are consistent and to automatically correct stripes where inconsistencies are found. BGI is a consistency check that automatically runs on all redundant arrays. Depending on workload, Dell recommends that consistency checks should be run manually on the virtual disks at least once every month to help ensure data integrity. Consistency checks and Background Read Patrol are complementary and both should be used.

See section 5 for details.

Enable Hot Spares

Hot spare functionality provides extra security, availability and redundancy by automatically replacing a failed disk in a RAID group and allowing the rebuild of the degraded array to begin immediately. Dell PERC controllers support Hot Spare functionality and it is recommended whenever possible.

See section 5 for details.

Document your configuration and keep the documentation current

Documenting your configuration facilitates faster and easier recovery should a failure occur. Make sure to include RAID levels, physical disks included in your virtual disks, firmware and driver versions and usage of hot spares in your documentation.

Perform periodic physical inspection of your connections and cabling

Damaged cables and loose connections may cause functional issues with your storage solution. Dell recommends a physical equipment audit two times a year or anytime after re-cabling or re-deploying your storage hardware.

3. Dell's SAS Product Offering

The PowerVault MD1000 is a feature-optimized storage expansion enclosure which utilizes the latest industry standard storage interconnect technology, Serial Attached SCSI (SAS). This 3U enclosure supports between 2 and 15 physical SAS drives. Along with Dell's host-based RAID controller, PERC 5/E, the PowerVault MD1000 storage enclosure introduces new levels of performance, capacity, and scalability. Major features of the PowerVault MD1000 and PERC 5/E solution include:

Performance

- Support for 3.0 Gbps SAS physical disks (both 10,000 and 15,000 RPM)
- External cable supports a SAS x4 wide-lane to achieve a total interface bandwidth of up to 12.0 Gbps connection to the host controller
- Host interconnect with the PERC 5/E host-based controller
- Support for RAID level 0

Availability

- Support for RAID levels 1, 5, 10 and 50
- Redundant, hot pluggable power supplies with integrated cooling fan modules
- Redundant enclosure management modules (EMMs)
- Hot pluggable physical disks

Scalability/Expandability

- Support for daisy-chaining up to three PowerVault MD1000 expansion enclosures per PERC 5/E connection
- Supports between 2 and 15 physical SAS drives
- Supports 36GB, 73GB, 146GB, and 300 GB 3.5-inch SAS physical disks

Ease-of-Use

- Common management software with PowerEdge™ servers through Dell OpenManage Server Administrator

PERC 5/E is the RAID controller used to connect the PowerVault MD1000 storage enclosure to one or two PowerEdge servers. It supports 3 Gbps Serial Attached SCSI (SAS) as the storage interconnect technology and PCI Express (PCI-E) as the host-based interconnect technology. The “E” in PERC 5/E stands for “**External**” because the PERC 5/E controller supports only physical disks that attach to a server externally.

The PERC 5/E controller offers:

- Intel IOP333 I/O processor based on Intel XScale Microarchitecture
- 256MB of customized DDR2 400MHz, Error-Correcting Code (ECC) cache memory
- 3 Gbps maximum speed for each SAS lane
- Two external x4 (“by four”) SAS ports, each aggregating 4 SAS lanes for a total bandwidth per port of 12.0 Gbps
- x8 PCI E host interface for a total bandwidth of 32.0 Gbps
- Up to 72 hours of intelligent, transportable, battery-backed, cache memory

For detailed information on the PERC 5/E controller, see section 6.

SAS Cabling

The PowerVault MD1000 storage enclosure and the PERC 5/E controller both support industry standard 3.0 Gbps SAS cables in 1m, 2m, and 4m cable lengths. Each cable supports x4 SAS connectors to deliver up to 12.0 Gbps of total bandwidth from the host to the enclosure. Only Dell-qualified cables are supported for connecting the PowerVault MD1000 storage enclosure to the PERC 5/E controller.

Physical Drive Support

The PowerVault MD1000 storage expansion enclosure supports the latest SAS physical disks, currently specified as 3.0 Gbps SAS. SAS solutions from Dell include both 10,000 RPM and 15,000 RPM spindle speeds and a variety of capacities to allow customers the maximum flexibility.

For the latest information on support for specific physical disks, see the Dell Storage web site at:

<http://www.us.dell.com/storage/>

3rd Party Hardware support

To help provide the best possible customer experience, Dell supports only hardware purchased direct from Dell for the PowerVault MD1000 and PERC 5/E controller. Dell-developed server and storage solutions include many thousands of person-hours of engineering testing and validation to help ensure the highest product quality. For example, physical disks purchased direct from Dell may include features not generally available to the rest of the industry. As such, Dell supports only Dell tested and qualified hardware. Hardware purchased direct from Dell carries the full Dell system limited warranty¹ and helps ensure full compatibility. Materials purchased from 3rd party vendors for use in Dell systems are not covered under Dell's limited warranty and may not deliver an acceptable customer experience.

Server Support

The PowerVault MD1000 storage enclosure and PERC 5/E solution are supported on the PowerEdge 1850, 2850, 6800, and 6850 servers.

4. PowerVault MD1000 Storage Enclosure Details

Enclosure Modes

The enclosure can be set to either unified or split mode through the use of a two-position switch located on the front panel of the enclosure. The enclosure can be configured into the selected mode only at power up. Any changes to the mode switch made while the enclosure is powered on will not take effect until the enclosure is powered off and back on again.

Note: Any time you power on the PowerVault MD1000 storage enclosure, ensure the mode switch is set in the desired position. If the position of the switch changes inadvertently, data loss could occur as the controller may recognize an inaccurate number of attached physical disks versus the previous mode. In order to cycle power on your MD1000, all attached servers, must be turned off.

Unified Topology

In unified mode, a single server has access to all fifteen physical disks in the PowerVault MD1000 storage enclosure through a single SAS cable. The unified mode can also provide a single server access to a maximum of forty five physical disks by daisy-chaining up to three enclosures from a single host port. The main advantage of unified mode is that it provides a high degree of physical disk scalability.

¹ For a copy of our guarantees or limited warranties, please write Dell USA L.P., Attn: Warranties, One Dell Way, Round Rock, TX 78682. For more information, visit www.dell.com/warranty.

Split Topology

In split mode, the enclosure is divided into two logical enclosures; with each host connection accessing its own set of physical disks. The primary Enclosure Management Module (EMM) (located on the left side of the enclosure when viewed from the rear), accesses physical disk slots 7 through 14. The secondary EMM accesses physical disk slots 0 through 6. To connect a server to an enclosure in split mode, the **In** port of each EMM should be attached to a connector of a PERC 5/E controller. The **Out** port of an EMM in split mode is disabled, since enclosure daisy-chaining is not supported in this mode.

Split mode is useful in deployments where a single PowerVault MD1000 storage enclosure help provide limited amounts of storage each for two different servers.

Note: In split mode, each host server can see its own physical disks (e.g. drive., physical disk 0 – 6 or 7 – 14) but not the other server's physical disks.

Note: Split mode does not support daisy-chaining.

Note: A system with a single EMM set in split mode will function properly, but the server will only be able to see the physical disks that are connected to the EMM.

Dual Hosts

Figure 3: Split mode configuration

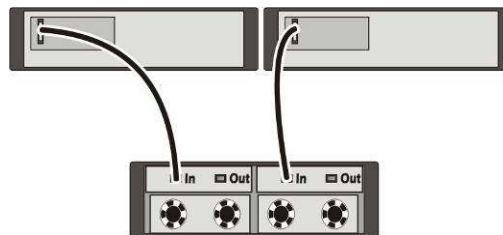

Daisy-Chaining Multiple PowerVault MD1000 Storage Enclosures

In unified mode, up to three enclosures may be daisy-chained together from a single PERC 5/E controller port. A maximum of six PowerVault MD1000 storage enclosures (3 enclosures per port) may be connected to a single PERC 5/E controller. (Note: Although this is a supported configuration, one should consider total solution availability before attaching this quantity of storage to a single-controller solution.). When connecting multiple enclosures, the first enclosure is connected to the PERC 5/E controller via the **In** port of the primary EMM. The second enclosure is connected from the **Out** port of the primary EMM on the first enclosure to the **In** port of the primary EMM on the second enclosure. The connection is made with a standard SAS cable. The third enclosure is connected in the same manner as the second enclosure.

Figure 4: Max configuration on a single PERC 5/E controller port

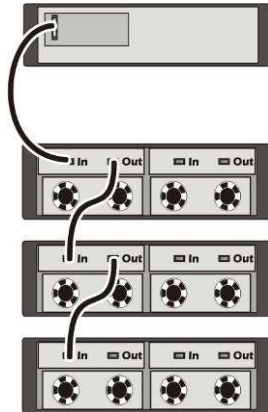
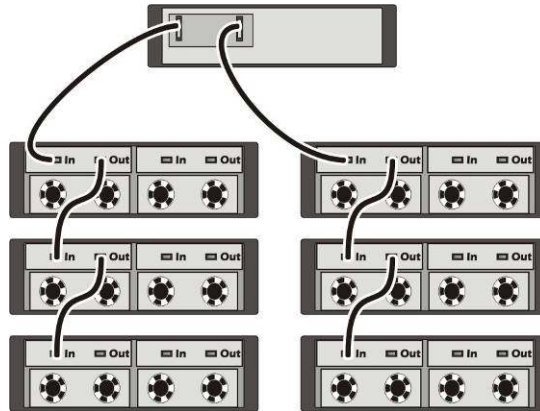

Figure 5: Max configuration on a single PERC 5/E controller (both ports connected)



PowerVault MD1000 – Common Features and Capabilities

Regardless of the topology, the PowerVault MD1000 storage enclosure provides a set of common features and capabilities.

World Wide Name (WWN) Assignment

The SAS standard requires that all devices on a SAS domain have a unique address, called a World Wide Name or WWN. The PowerVault MD1000 storage enclosure complies with the SAS standard. For more information on WWN assignment, please refer to the SAS Specification referenced in Appendix A.

Mixing Physical Disk Capacities

By supporting the mixing of physical disk of different sizes within an enclosure, the PowerVault MD1000 storage enclosure enables optimal matching of physical disk type to the requirements of multiple applications. Mixing of physical disk sizes is supported but not recommended within a single RAID group. The PowerVault MD1000 storage enclosure supports 36 GB, 73 GB, 146 GB, and 300 GB capacities for SAS. When operating in a RAID configuration, the lowest capacity physical disk defines the RAID virtual disk size. For example, a RAID 1 configuration with two different sized physical disks, one 36 GB and another 146 GB physical disk, will be limited to 36 GB. If the same two physical disks were configured in RAID 0 configuration, the virtual disk size would be limited to 73 GB (the equivalent of two 36 GB physical disks in RAID 0 configuration).

Mixing Physical Disk Spindle Speeds

Mixing different physical disk spindle speeds is supported, but not recommended within a single RAID group. The PowerVault MD1000 storage enclosure supports 10,000 and 15,000 RPM spindle speeds. Depending upon the RAID configuration, the lowest spindle speed may dictate the maximum performance of the RAID group.

SCSI Enclosure Services (SES)

The EMM continuously monitors environmental variables such as temperature and voltage. The PowerVault MD1000 storage enclosure works in conjunction with Dell OpenManage Server Administrator to set trigger thresholds that warn the user when these variables exceed safe operating levels. The enclosure will automatically power down when these environmental variables exceed a critical threshold level in order to avoid potential equipment damage. Both local visual indicators (e.g. LEDs) and audio alerts are triggered when faults are detected. The audio alerts on the enclosure are disabled by default, but can be enabled using Server Administrator. The following SES functions are provided by the EMMs in the PowerVault MD1000 storage enclosure:

- Enclosure shelf faults detection
- Physical disk Power/Fault/Offline status
- Power supply status and shutdown capabilities
- Fan speed status and control
- Temperature monitoring
- Over/under temperature shutdown capabilities
- Alarms (local audible and visual LED indicators)

Hot Plugging

- The PowerVault MD1000 storage enclosure is designed for hot plugging certain components to help prevent damage when pulling or replacing. Hot plugging is a concept which allows for the safe removal and replacement of components while the power is still on. Hot plugging allows server applications and disk activities to continue uninterrupted, while maintenance or repair actions take place. Additional steps may be required for physical disks to become usable. See the RAID controller User's Guide for more information.
- Hot Pluggable Devices
 - Physical disk (all Disk I/O activities must be halted first)
 - Power supply module/ cooling fan module

Note: Hot plugging of SAS cables is not supported.

External SAS Cables

Depending on the enclosure topology, one or two external SAS cables may be attached between the host system(s) and the PowerVault MD1000 storage enclosure. SAS cables use four active 3 Gbps SAS lanes in a single cable to deliver an aggregate of 12.0 Gbps connection. All PowerVault MD1000 SAS cables purchased from Dell have been tested and comply with the ANSI SAS 1.0 standard. Dell supports using only Dell-provided cables.

External SAS Connector Types

SAS uses a 25-pin connector whose specification is governed by the SFF-8470 specification. For more information, refer to the specification referenced in Appendix A.

Regardless of the topology, the PowerVault MD1000 storage enclosure also provides some common capabilities as listed below:

Redundancy Capabilities

- *Management Redundancy*

With two EMMs installed, the PowerVault MD1000 storage enclosure's internal enclosure functions on the PowerVault MD1000, such as temperature regulation, LED control, and alarm control, are maintained in the event of an EMM failure. However, even with dual EMMs installed, enclosure status will not be reported to the host in the event of an EMM failure.

- *Power Supply and Cooling Redundancy*

The PowerVault MD1000 storage enclosure requires that both power supplies be installed for normal operation. The system can operate using a single power supply for a limited time in the event a power supply fails or is removed for service.

The PowerVault MD1000 storage enclosure provides four individually controlled fans, two installed in each power supply. The unit is thermally designed to continue operating in the event of one fan blower failure (3+1 cooling redundancy). In the event of a fan failure, the power supply containing the failed fan must be replaced.

Reliability Capabilities

- *Thermal Reliability*

A fully-redundant PowerVault MD1000 storage enclosure contains four digital temperature sensors, two on the backplane and one on each EMM. In conjunction with the SES processor, the temperature sensors provide device protection against adverse thermal conditions. The PowerVault MD1000 storage enclosure is designed to operate within an ambient temperature range of 10°C (50°F) to 35°C (95°F). When either of the backplane sensors detects temperature below 3°C (37.4°F) or above 55°C (131°F), the SES processor notifies the host of a critical temperature situation. This triggers the host to perform a graceful shutdown of the enclosure within three minutes. In the event that the host is unable to initiate the enclosure shutdown process or a host is not connected to the enclosure, the PowerVault MD1000 storage enclosure has an embedded thermal shutdown feature. This is activated by the SES processor in either of the following cases:

- Either of the backplane temperature sensors detects temperature below -2°C (28.4°F) or above 60°C (140°F).
- Temperature sensor on an EMM detects temperatures below -2°C (28.4°F) or above 65°C (149°F).

The PowerVault MD1000 storage enclosure shuts down within 5 seconds of the activation of an embedded thermal shutdown.

PowerVault MD1000 Serviceability Capabilities

- All the major PowerVault MD1000 components are easily accessible and replaceable even when in a rack.
- The PowerVault MD1000 storage enclosure is equipped with LED indicators for visual status reporting on the status of internal components.
- The PowerVault MD1000 storage enclosure's audible alarm notifies users of critical/non-critical status (for details, see PowerVault MD1000 Hardware Owners Manual). Status is also reported to the host system's management tool, Server Administrator (for details, see the OpenManage User's Guide.)

5. PERC 5/E Controller - Detailed Features

PERC 5/E is the RAID controller used to connect the PowerVault MD1000 storage enclosure with PowerEdge servers. It supports 3 Gbps Serial Attached SCSI (SAS) as the storage interconnect technology and PCI -E as the host-based interconnect technology. PERC 5/E controller supports RAID levels 0, 1, 5, 10 and 50.

Considerations when implementing a RAID Solution

The selection of a RAID solution in any environment is governed by several aspects including controller and capacity requirements. Each of these factors is discussed in detail in the following sections.

Controller Features

The Server Administrator is the recommended application for configuring and managing the PowerVault MD1000 storage enclosure. Apart from the Server Administrator software, the BIOS configuration utility (<CTRL> <R>) may be used to perform pre-OS configuration and fault recovery. Some of the key features of the PERC 5/E controller are listed here:

- *Virtual Disk Initialization*

PERC 5/E controller is capable of performing initialization on the virtual disk(s) by either writing 0's to a portion of the physical disk (fast initialization) or to the entire physical disk (full initialization). Full initialization guarantees that any legacy data is cleared and all sectors are healthy.

- *Background Patrol Read*

Background Patrol Read is an automatically scheduled background task that scans and resolves possible physical disk errors that may lead to physical disk failure and result in data integrity issues. Dell recommends implementing Background Patrol Read in all the configurations.

- *Consistency Check/Background Initialization (BGI)*

Consistency checks / BGI are performed by PERC 5/E controller to verify that all stripes in a redundant virtual disk are consistent and to automatically correct stripes where inconsistencies are found. BGI is a consistency check that automatically runs on all redundant arrays. Depending on workload, Dell recommends that consistency checks are run manually on virtual disks at least once every month to ensure data integrity. Running a consistency check is complement to running Patrol Read and both should be used.

- *RAID Level Migration*

Changing the RAID level of a virtual disk from the existing level (e.g. RAID 1) to another level (e.g. RAID 5) is called RAID level migration. Dell recommends that data in the virtual disk be backed up before a RAID level migration is initiated. Dell also strongly recommends that the size of the physical disks to which the RAID level is to be migrated is greater than or equal to the size of the physical disks in the existing virtual disk. Dell supports RAID level migration as follows:

RAID 1 to RAID 0
RAID 0 to RAID 1
RAID 5 to RAID 0
RAID 0 to RAID 5
RAID 1 to RAID 5

- *Capacity Expansion*

Expanding the capacity of a virtual disk by adding another physical disk is called capacity expansion. Dell supports capacity expansion on all the supported RAID levels except RAID 1. Dell recommends that the data in the virtual disk be backed up before capacity expansion is initiated. For more details on capacity expansion, see the Dell PERC 5/E User's Guide.

- *Controller Write Cache Policy Options*

Write-Back Caching

In write-back caching, data transfer is completed when the controller cache receives all data from host for the write transaction. Write-back caching is faster than write through caching. The main advantage of write-back caching is improved performance since the controller does not have to wait for an acknowledgement from the physical disk before proceeding. The battery backup unit for the controller is required to enable write-back caching. For more details on write-back caching, see the Dell PERC 5/E User's Guide.

Write-Through Caching

In write-through caching, a data transfer is completed when the disk subsystem receives all of the data from the host. Write-through caching provides additional security because data must be committed to the physical disk before proceeding. There may be a minimal performance impact since the controller must wait for the physical disk to return a good status to the controller before proceeding to the next operation.

- *Hot Spare Support*

When a physical disk is assigned to a virtual disk as a hot spare, the PERC 5/E controller will automatically rebuild the virtual disk using the hot spare in the event of a failed physical disk. This restores the virtual disk to optimal redundancy. The hot spare disk must be equal to or greater than the largest physical disk size within any of the virtual disks. Dell recommends assigning hot spares to redundant virtual disks only, (i.e. RAID 1, RAID 5, RAID 10 and RAID 50.)

Global Hot Spare

A global hot spare is a backup physical disk capable of replacing a failed physical disk in any virtual disk on PERC 5/E controller. The capacity of a global hot spare should be greater than or equal to the largest physical disk in all the disk groups.

Dedicated Hot Spare

A dedicated hot spare is a backup physical disk capable of replacing a failed physical disk in a specific PERC 5/E virtual disk. The capacity of a dedicated hot spare should be greater than or equal to the largest physical disk in the virtual disk to which it is assigned. Dell recommends assigning dedicated hot spares to all business critical virtual disks.

- *Disk Roaming*

Disk roaming is initiated when the physical disks are changed to different ports on the same controller. The physical disk roaming feature will detect the RAID configuration from the configuration metadata residing on the physical disk.

- *Rebuild*

The process of restoring the redundancy of a RAID 1, 5, 10 or 50 virtual disk is called rebuilding. The rebuilding process can be initiated manually or automatically. Dell recommends choosing the automatic rebuild option to prevent running in the degraded mode for an extended period of time.

- *Mixed-Size Physical Disk Within RAID 10 or RAID 50*

When mixing physical disk sizes in RAID 10 or RAID 50, the controller will not coerce the larger virtual disks to match the size of the smallest virtual disk. PERC 5/E controller will stripe across all disks until the smallest one is full, then it will continue to stripe across the remaining disks until the next one is full, and so on until all the available space is used. This process can impact performance as the array fills up, since the numbers of stripes decreases as disks fill up.

Capacity Requirements

The PERC 5/E controller supports up to sixty four virtual disks simultaneously of which each virtual disk can contain up to thirty two physical disks. The maximum number of total virtual disks that can be supported on each physical disk is sixteen. PERC 5 controllers support virtual disks greater than 2 TB in size, but Dell recommends checking the capacity of the operating systems to support boot volumes of that capacity.

<http://www.microsoft.com/windowsserversystem/storage/getstorfacts.mspx>

http://www.dell.com/downloads/global/vectors/2004_2tblun.pdf

Table 2: PERC 5/E controller features

Feature	Comment
SAS Technology	3Gbps
Host Bus Interface	x8 PCI Express
Internal connectors	N/A
External Connectors	2
RAID Levels Supported	0, 1, 5, 10, 50
Cache Size (DIMM)	256MB DDR2
Write Cache Options	Write-Through, Write-Back
Read Cache Options	Read-Ahead, No Read Ahead
BBU Battery Life	Up to 72 hours
Maximum Number of Virtual Disks/Controller	64
Maximum Number of Physical Drives/Virtual Disk	32
Form Factor	Full Height, Half-Length PCI Adapter card
I/O Processor (IOP)	Intel IOP333

6. Dell OpenManage Server Administrator

Dell OpenManage Server Administrator is a management application for configuring PowerEdge servers. The Server Administrator's configuration abilities for host-based RAID and non-RAID disk storage are of particular interest for this paper. The Server Administrator enables you to perform controller and enclosure functions from a single, graphical or command line interface. The graphical user interface (GUI) is wizard-driven with features for novice and advanced users and detailed online help. The command line interface is fully-featured and scriptable.

The Server Administrator provides SAS support with the PERC 5/E controller and the PowerVault MD1000 storage enclosure. Server Administrator also supports the SCSI and ATA technologies.

Managing the PERC 5/E Controller and the PowerVault MD1000 Storage Enclosure

After installing Server Administrator, the user can expand the storage object in the tree view to display the storage components attached to the system. These components include supported controllers and enclosures, virtual disks, physical disks, and the connectors (SAS ports and/or SCSI channels) that comprise the topography of all attached storage.

The PERC 5/E controller and the PowerVault MD1000 storage enclosure are represented in Server Administrator's tree view. You can select the PERC 5/E object and the PowerVault MD1000 object to display the status and to provide access to PERC 5/E controller and PowerVault storage enclosure tasks.

Using the Create Virtual Disk Wizards

You can create virtual disks using either Server Administrator's *Create Virtual Disk Express* or the *Create Virtual Disk Advanced* wizard. These wizards enable you to quickly configure virtual disk attributes, such as the RAID level, size, and physical disk selection.

The *Express* wizard displays the RAID levels supported by the controller and enables you to select the desired RAID level and the disk size for your virtual disk. After you select the RAID level, the *Express* wizard selects an appropriate physical disk given the size of the physical disks and the available disk space. The *Express* wizard displays the physical disks it has selected so that you can confirm the selection before creating the virtual disk.

The *Advanced* wizard allows you to select physical disks and specify additional virtual disk properties such as the read, write, and cache policies.

Figure 6: Screenshot of Create Virtual Disk Advanced Wizard with Disk Selection Displayed

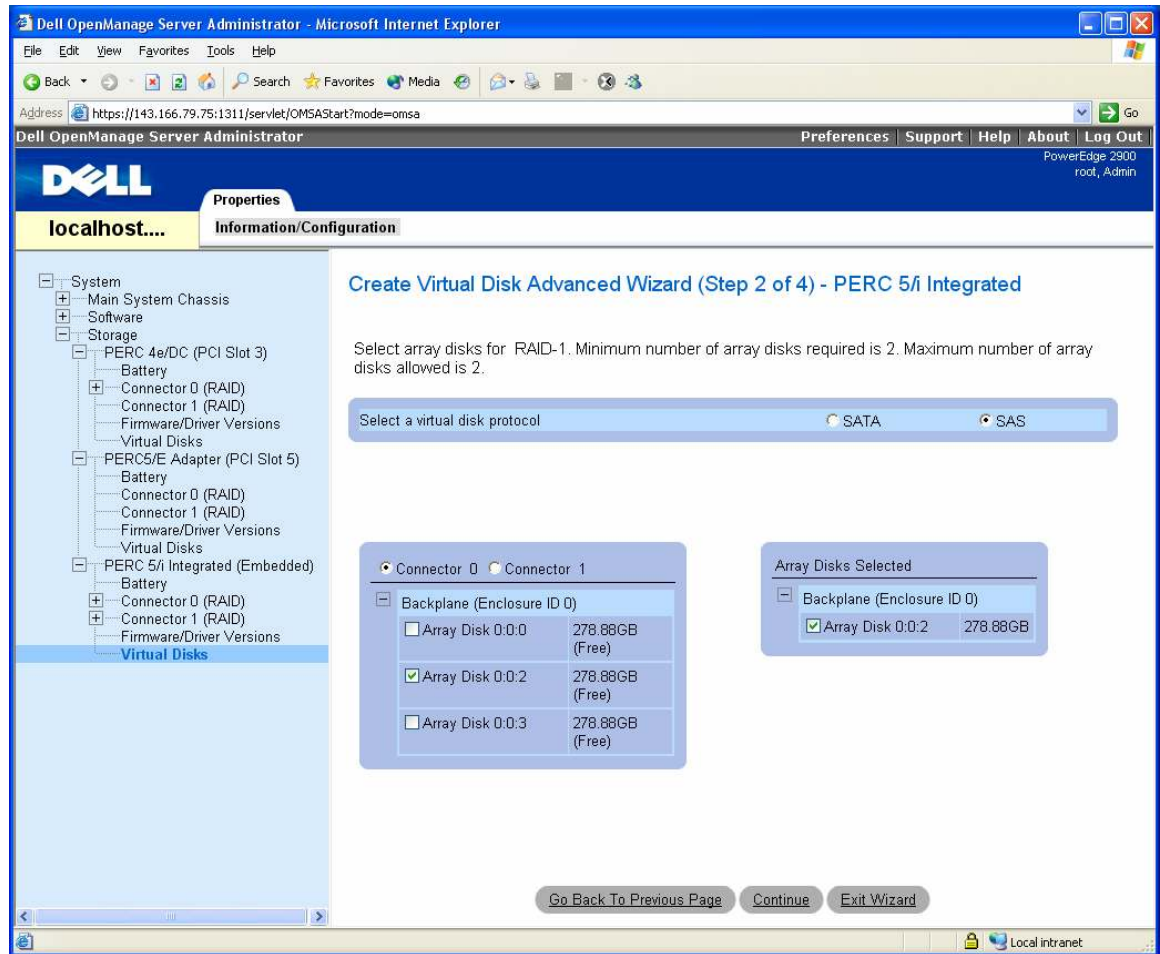

The *Create Virtual Disk Express* and *Create Virtual Disk Advanced* wizards set the virtual disk initialization to "Fast Initialize" by default. After completing the creation of a virtual disk using the Express or Advanced wizard, the PERC 5/E controller implements the virtual disk configuration on the selected physical disks and completes a fast initialize.

Reconfiguring Virtual Disks – RAID Migration and Capacity Expansion

Server Administrator supports RAID migration and capacity expansion with the *Reconfigure Virtual Disk* wizard. This wizard enables you to change a virtual disk's RAID level or increase its size by adding one or more physical disks.

The possibilities for reconfiguring a virtual disk depend on the capabilities of the RAID controller, the existing RAID level, and the available physical disks. The following table describes the possible reconfiguration scenarios on the PERC 5/E controller.

Table 3: Virtual disk reconfiguration on the PERC 5/E RAID controller

PERC 5/Controller Starting RAID Level	Target RAID Level	Disk Requirements
RAID 0	RAID 0	Add at least one additional disk
RAID 0 (on a single disk)	RAID 1	Add a single disk
RAID 0	RAID 5	Add at least one additional disk
RAID 1	RAID 0	With or without adding additional disks
RAID 1	RAID 5	Add additional disks
RAID 5	RAID 0	With or without adding additional disks
RAID 5	RAID 5	Add additional disks

Other considerations may apply to virtual disk reconfiguration. For example, you cannot create more than sixty four virtual disks on the PERC 5/E controller. After reaching this limit, you will not be able to reconfigure any of the virtual disks on the controller.

The *Reconfigure Virtual Disk* wizard displays the available target RAID levels and the physical disks. After you have selected the new RAID level and the physical disks, the *Reconfigure Virtual Disk* wizard displays the previous and the new configuration so that you can confirm or reject the changes.

Moving Physical Disks and Virtual Disk Configurations – Disk Roaming and Disk Migration

Disk roaming refers to physically moving a disk from one cable connection to another or from one backplane or enclosure slot to another on the same controller. The PERC 5/E controller recognizes the relocated physical disks and logically restores the physical disk and its data to the proper virtual disk. Disk roaming can be performed only when the system is shut down.

Disk migration refers to moving physical disks from one controller to another. Virtual disks residing on the relocated physical disks are identified as a *foreign configuration* on the receiving PERC 5/E controller. The Server Administrator enables you to import the foreign configuration so that the migrated virtual disks can be managed on the receiving PERC 5/E controller.

The following conditions must be met to successfully migrate the physical disks and their resident virtual disks:

- Virtual disks on a SAS controller can only be migrated to another SAS controller.
- When moving an enclosure, power down the enclosure and the server before moving the enclosure. The enclosure can be moved to any connector number on the receiving controller.

The following procedure describes how to migrate the physical disks from one controller to another:

1. Shut down the system from which the physical disks are being moved.
2. Shut down the server of the receiving controller if it does not have a preexisting virtual disk configuration.
3. Place the physical disks into the new enclosure.
4. Start up the system connected to the receiving controller.
5. Use Server Administrator's *Import Foreign Configuration* wizard to import the migrated virtual disks on the receiving controller.

Importing Migrated Virtual Disks

After migrating the physical disks, Server Administrator enables you to import the virtual disks or "foreign" configuration that reside on the relocated physical disks.

To be imported, the foreign configuration must contain a virtual disk that is in either "Ready" or "Degraded" state. For proper completion of this task, all of the virtual disk data must be present. If the virtual disk is using a redundant RAID level, the additional redundant data does not need to be present. For example, if the foreign configuration contains one side of a mirror in a RAID 1 virtual disk, then the virtual disk is in a degraded state and can be imported. On the other hand, if the foreign configuration contains only one physical disk that was originally configured as a RAID 5 using three physical disks, then the RAID 5 virtual disk cannot be imported.

In addition to the virtual disks, a foreign configuration may consist of a physical disk that was assigned as a hot spare on one controller and then moved to another controller. The *Import Foreign Configuration* wizard imports the new physical disk as a hot spare. If the physical disk was a dedicated hot spare on the previous controller, but the virtual disk to which the hot spare was assigned is no longer present in the foreign configuration, then the physical disk is imported as a global hot spare.

If a physical disk contains all or some portion of a foreign configuration, then Server Administrator displays the physical disk state as "Foreign."

Figure 7: Physical Disk with a Foreign State

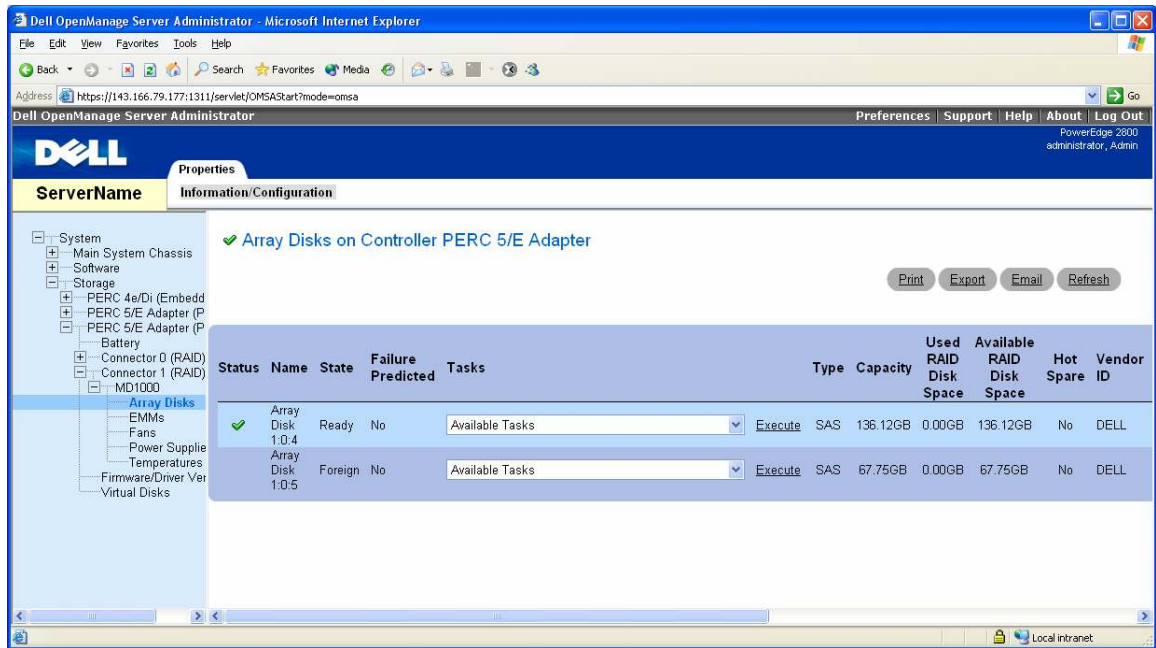

The Server Administrator displays the *Import Foreign Configuration* task when the controller detects a foreign configuration. If you have an incomplete foreign configuration which cannot be imported, using the *Clear Foreign Configuration* task, erases the foreign data on the physical disks.

Figure 8: Controller Tasks Drop-down Menu With the Import Foreign Configuration and Clear Foreign Configuration Tasks Displayed

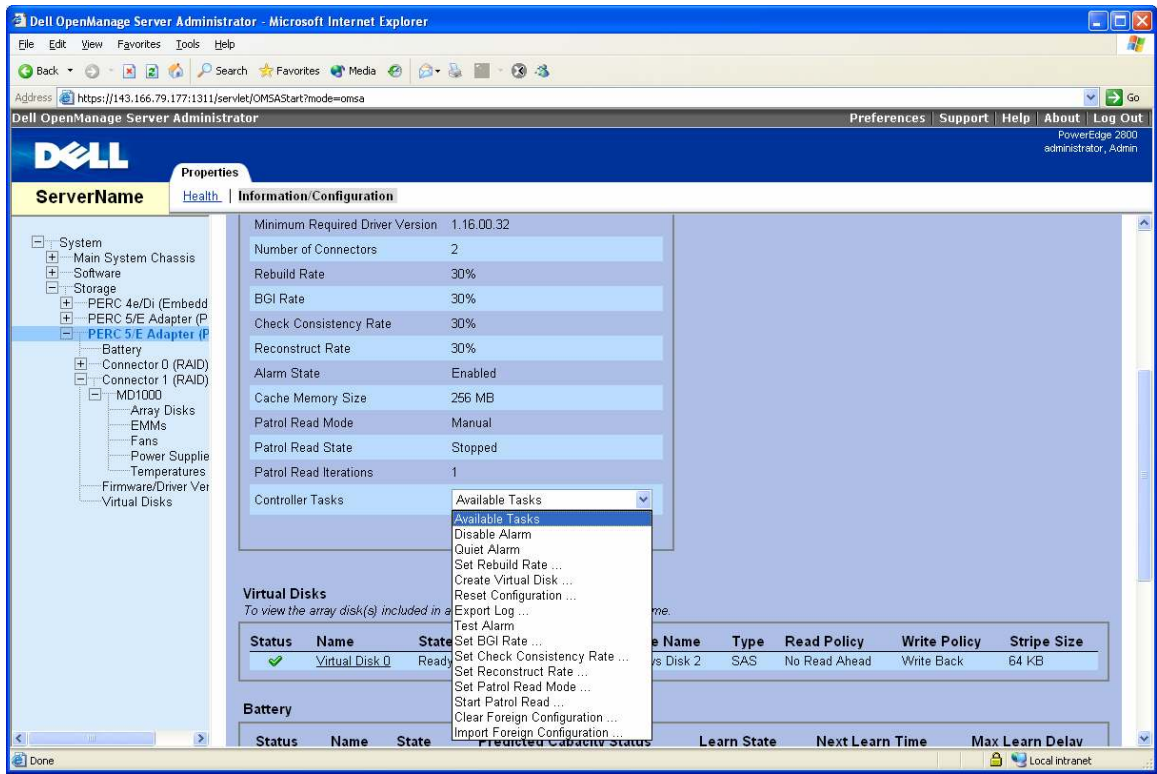

Upgrading from Dell OpenManage Array Manager

Dell has discontinued the release of Dell OpenManage Array Manager. Server Administrator is a replacement for Array Manager. Customers wishing to take advantage of SAS technology must upgrade their Array Manager installation to Server Administrator. Server Administrator also provides Linux support which was not offered with Array Manager.

Note: OMSA: Server Administrator does not support NetWare. Existing NetWare customers may continue to use their Array Manager licenses for existing systems, but additional licenses will not be granted for new systems.

Note: Server Administrator does not provide support for Fibre channel arrays.

The following sections describe the considerations for upgrading to Server Administrator.

Virtual Disk Preservation

You can preserve assigned virtual disk names when migrating from Array Manager to Server Administrator. To do so, you must not uninstall Array Manager prior to installing Server Administrator. If Array Manager is uninstalled prior to installing Server Administrator, the virtual disks are renamed. Irrespective of whether Array Manager is uninstalled, Server Administrator identifies and manages the virtual disks created with Array Manager.

SNMP Traps

The architecture for handling SNMP traps and the Management Information Base (MIB) is different in Server Administrator than in Array Manager. You may need to modify the applications that are customized to receive SNMP traps from Array Manager.

Event Numbering

The numbering scheme for Storage Management alerts or events is different than the numbers used for the corresponding Array Manager events. See the Alert Messages chapter in the Storage Management online help for more information.

7. Storage Applications and Components

Identify customer usage model and needs

In order to select the correct storage solution, it is important to understand the application and user requirements. A good starting point is to use the following basic storage profiling considerations.

Table 4: Storage Profiling Considerations

Characteristic	Values	Description
Performance	<ul style="list-style-type: none"> Bandwidth (MB per sec.) I/O size (KB/MB) I/O Profile (read/write and random/sequential access mix) Latency 	Performance is the overall ability of the solution to read and write data to the disk. The performance requirements are usually determined by the type of application being utilized. Different applications have different performance requirements. For example, a database or e-mail server has mostly random disk access operations while a streaming media server would have mostly sequential disk access.
Storage Capacity Needs	Gigabytes	Storage capacity is the amount of storage space required by the application and user data. For example, e-mail storage for 100 users would require much less storage capacity than an e-mail store for 1000 users.
Storage Growth Rate	Percent increase per year	Storage growth is the expected increase in the amount of the capacity that will be required as the usage increases. This can be estimated by forecasting the number of users or clients expected to access the application in the future.
Criticality	Low, Medium, High, Very High	Criticality defines the impact to business needs if the storage is offline. This characteristic is important for choosing the right RAID level.

Picking a solution based on the application profile

One of the most important factors to consider when selecting a storage solution is the type of application that will be utilizing the storage solution. This defines the overall purpose of the server/storage solution and will determine what RAID configuration will be optimal for the application. Table 5 outlines the recommended RAID solution based on the usage of the server.

Table 5: RAID Configuration Recommendations

Application	RAID Level					
	Concatenated	0	1	10	5	50
Email	<input type="checkbox"/>	<input type="checkbox"/>	<input type="checkbox"/>	<input checked="" type="checkbox"/>	<input checked="" type="checkbox"/>	<input checked="" type="checkbox"/>
Web	<input type="checkbox"/>	<input checked="" type="checkbox"/>	<input checked="" type="checkbox"/>	<input checked="" type="checkbox"/>	<input checked="" type="checkbox"/>	<input checked="" type="checkbox"/>
Database or On-line transaction processing	<input type="checkbox"/>	<input type="checkbox"/>	<input type="checkbox"/>	<input checked="" type="checkbox"/>	<input checked="" type="checkbox"/>	<input checked="" type="checkbox"/>
Streaming Media	<input type="checkbox"/>	<input checked="" type="checkbox"/>	<input type="checkbox"/>	<input type="checkbox"/>	<input checked="" type="checkbox"/>	<input checked="" type="checkbox"/>
File – Archival	<input type="checkbox"/>	<input type="checkbox"/>	<input type="checkbox"/>	<input checked="" type="checkbox"/>	<input checked="" type="checkbox"/>	<input checked="" type="checkbox"/>
File – User File Stores	<input type="checkbox"/>	<input type="checkbox"/>	<input type="checkbox"/>	<input type="checkbox"/>	<input checked="" type="checkbox"/>	<input checked="" type="checkbox"/>
<input checked="" type="checkbox"/>	Recommended	<input type="checkbox"/>	Not Recommended	<input type="checkbox"/>	Possible	

General RAID Configuration Guidelines

RAID 0

RAID 0 is generally not a recommended solution due to lack of data redundancy and protection. However, it may be utilized in situations where this is not required and maximum storage capacity and performance are essential.

RAID 1

A RAID 1 solution, while not ideal, could be utilized for small workgroup servers or servers with low storage capacity and growth requirements. Any server beyond a small workgroup server is likely to need more storage and consequently, a more efficient RAID solution.

RAID 10

RAID 10 has good I/O performance, excellent availability and redundancy. The biggest drawback of RAID 10 is that it requires twice the number of physical disks needed for data. This RAID configuration should be used in situations requiring maximum availability, redundancy, and performance.

RAID 5

RAID 5 has good I/O performance, data protection and requires only one additional physical disk than the number needed for data. RAID 5 should be used in situations where maximum storage capacity is required along with a moderate amount of data protection.

RAID 50

A balance between RAID 5 and RAID 10, this solution offers good I/O performance, availability and good storage capacity. This configuration offers slightly higher performance than RAID 5, but requires multiple additional physical disks than the number needed for data. It does however provide greater storage capacity than a RAID 10 solution with a decrease in performance and data protection. This should be used in situations where greater redundancy and data protection is required as well as a reasonable storage capacity.

Concatenated

This solution is not recommended due to lack of data protection and redundancy and no performance gain.

Note: For more details on RAID configurations see the Dell 'Getting Started with RAID' document (<http://support.dell.com/support/edocs/storage/RAID/RAIDbk0.pdf>)

Application specific guidelines*E-Mail Servers*

The storage requirements for e-mail servers can vary depending on the size, the amount, and the type of users. While small departmental e-mail servers may work well with a small amount of storage and limited features; large corporate e-mail servers normally require greater storage capacity, very high availability, performance, and scalability. I/O profiles will vary depending on the number of users and type of mail and attachments sent.

Table 6: Email Server General I/O profile

I/O Profile (Read/Write)	I/O Profile (Sequential/Random)	Bandwidth	I/O Size	Latency Sensitivity	Growth Rate	Criticality
60/40	Random	Heavy	4k	High	High	High

Table 7: Email Sever RAID Guidelines

Application	RAID Level					
	Concatenated	0	1	10	5	50
E-Mail	<input checked="" type="checkbox"/>	<input checked="" type="checkbox"/>	<input type="checkbox"/>	<input checked="" type="checkbox"/>	<input checked="" type="checkbox"/>	<input checked="" type="checkbox"/>

Recommended Not Recommended Possible

Recommended:

- RAID 10 – Recommended for mission-critical e-mail servers where availability and redundancy and/or performance are the highest priority and where reduced storage capacity is acceptable.
- RAID 5 – Recommended for e-mail servers that require maximum storage capacity and moderate data protection and performance.
- RAID 50 – Recommended for those solutions that require greater redundancy and data protection and a balance between storage capacity and performance.

Possible:

- RAID 1 – Possible solution for small e-mail servers which do not require high storage capacity.

Not recommended:

- RAID 0, Concatenated – Not recommended due to lack of redundancy and data protection.

Note: While these configurations are not recommended, they can be configured and utilized.

Web Servers

Web servers are usually high traffic systems where read operations are the most common disk activity as web pages are requested by users. They can be intranet sites with minimal internal company traffic or global internet portal sites that receive hundreds of thousands of users daily. Performance is generally the main concern with redundancy and data protection being less of a concern. For large web sites, there are usually several web servers responding to client requests and as a result the need for redundancy and data protection is not as important. Also web servers may not require as much scalability or disk capacity since website content is relatively static and changes are usually minor content modifications.

Table 8: Web General IO profile

I/O Profile (Read/Write)	I/O Profile (Sequential/Random)	Bandwidth	I/O Size	Latency Sensitivity	Growth Rate	Criticality
95/5	Random	Moderate	< 64k	Moderate	Low	High

Table 9: Web RAID Guidelines

Application	RAID Level					
	Concatenated	0	1	10	5	50
Database	<input checked="" type="checkbox"/>	<input checked="" type="checkbox"/>	<input checked="" type="checkbox"/>	<input checked="" type="checkbox"/>	<input checked="" type="checkbox"/>	<input checked="" type="checkbox"/>

Recommended Not Recommended Possible

Recommended:

- RAID 10 – Recommended for enterprise web server solutions where availability and redundancy and performance are the highest priority, usually for stand-alone portal sites that are critical to the organization’s business.
- RAID 5 – Recommended for web servers that require maximum storage capacity and moderate data protection and performance.
- RAID 50 – Recommended for those solutions that require a balance between storage capacity and performance.
- RAID 0 – Recommended for solutions where the web server will be part of a group of web servers that service a large internet portal and performance is the highest concern. In this situation, availability and redundancy are addressed by the cluster group and do not need to occur at the disk level.
- RAID 1 – Good solution for small websites which do not require high storage capacity.

Not recommended:

- Concatenated - This solution is not recommended due to lack of redundancy and data protection

Note: While this configuration is not recommended, it can be configured and utilized.

Database or Online Transaction Processing Servers

Database servers can range from simple workgroup databases like Microsoft® Access with a few hundred users to mission-critical enterprise databases like Oracle or SQL Server with thousands of users. Database applications will always benefit from some data protection while other requirements such as performance and availability will vary. As a general rule, the more critical the database, greater is the need for data protection. Additionally, the performance requirements increase relative to the number of users accessing the database.

Online Transaction Processing (OLTP) oriented servers are used in a number of industries for the entry and retrieval of transactions. For example, OLTP is common in banking, airlines, mail-order, and supermarkets. These servers are generally mission-critical and require maximum availability and redundancy possible.

Table 10: Database or OLTP General IO profile

I/O Profile (Read/Write)	I/O Profile (Sequential/Random)	Bandwidth	I/O Size	Latency Sensitivity	Growth Rate	Criticality
80/20	Random	Moderate	8k	Moderate	Low	High

Table 11: OLTP RAID Guidelines

Application	RAID Level					
	Concatenated	0	1	10	5	50
OLTP	☒	☒	☐	☑	☑	☑
	☑ Recommended	☒ Not Recommended			☐ Possible	

Recommended:

- RAID 10 – Since OLTP systems are critical for most business, this RAID configuration is highly recommended due to the high availability and redundancy and good performance.
- RAID 5 – Recommended for OLTP servers that require maximum storage capacity and moderate data protection and performance.
- RAID 50 – Recommended for those solutions that require a balance between storage capacity and performance.

Possible:

- RAID 1 – Possible solution for situations which do not require high storage capacity.

Not recommended:

- RAID 0, Concatenated - These are not recommended due to lack of redundancy and data protection.

Note: While these configurations are not recommended, they can be configured and utilized

File Servers

File servers can be used for file archival or more dynamic storage where files are changed, added and deleted on a daily basis. These servers range from workgroup to the corporate level. Storage capacity is a key attribute of these servers as users add more and more files. File servers are generally not mission critical systems so lower levels of availability and redundancy are acceptable as data is usually backed up and can be restored in a matter of hours.

Archival file server characteristics and recommendations:

Table 12: Archival File Server General I/O profile

I/O Profile (Read/Write)	I/O Profile (Sequential/Random)	Bandwidth	I/O Size	Latency Sensitivity	Growth Rate	Criticality
90/10	Sequential	Moderate	>64k	High	Varies	Low

Table 13: Archival File Server RAID Guidelines

Application	RAID Level					
	Concatenated	0	1	10	5	50
File - Archival	<input checked="" type="checkbox"/>	<input checked="" type="checkbox"/>	<input type="checkbox"/>	<input checked="" type="checkbox"/>	<input checked="" type="checkbox"/>	<input checked="" type="checkbox"/>

Recommended
 Not Recommended
 Possible

Recommended:

- RAID 10 – Recommended due to high availability, redundancy, and good performance.
- RAID 5 – Recommended for file servers that require maximum storage capacity and moderate data protection and performance.
- RAID 50 – Recommended for those solutions that require a balance between storage capacity and performance.

Possible:

- RAID 1 – Possible solution in situations which do not require high storage capacity.

Not recommended:

- RAID 0, Concatenated - These are not recommended due to lack of redundancy and data protection. Even for long term archival storage which is intended to be a backup of important files, it is not a recommended solution.

Note: While these configurations are not recommended, they can be configured and utilized.

User file store characteristics and recommendations

Table 14: User Store File Server General IO profile

I/O Profile (Read/Write)	I/O Profile (Sequential/Random)	Bandwidth	I/O Size	Latency Sensitivity	Growth Rate	Criticality
80/20	Sequential	Heavy	>64k	High	Varies	Moderate

Table 15: User Store File Server RAID Guidelines

Application	RAID Level					
	Concatenated	0	1	10	5	50
File – User file stores	<input type="checkbox"/>	<input type="checkbox"/>	<input type="checkbox"/>	<input type="checkbox"/>	<input checked="" type="checkbox"/>	<input checked="" type="checkbox"/>

Recommended
 Not Recommended
 Possible

Recommended:

- RAID 5 – Recommended for file servers that require maximum storage capacity and moderate data protection and performance.
- RAID 50 – Recommended for those solutions that require a balance between storage capacity and performance.

Possible:

- RAID 1 – Possible solution for situations which do not require high storage capacity.
- RAID 10 – Possible solution for situations that require greater availability and redundancy but not as much disk capacity.
- RAID 0 – While this solution is not redundant, RAID 0 may be useful for file servers that require better performance and maximum storage capacity, for example, where backups are expected to maintain data in the event of a failure.
- Concatenated – This solution could be used for situations that require maximum scalability as physical disks could be added as storage needs grow. For file servers that can afford some downtime and rely on backups to restore data, this could be a solution.

Streaming Media Servers

Streaming media servers are systems that provide web-casting, video conferencing, internet entertainment (e.g. Internet TV or Internet radio), and multimedia services. These systems generally require a balance between storage capacity, availability, redundancy, and performance. Like web servers, they may also be part of a group of systems that work together to provide content.

Table 16: Streaming Media IO profile

<i>I/O Profile (Read/Write)</i>	<i>I/O Profile (Sequential/Random)</i>	<i>Bandwidth</i>	<i>I/O Size</i>	<i>Latency Sensitivity</i>	<i>Growth Rate</i>	<i>Criticality</i>
98/2	Sequential	Heavy	>64k	High	High	Varies

Table 17: Streaming Media RAID Guidelines

<i>Application</i>	<i>RAID Level</i>					
	<i>Concatenated</i>	<i>0</i>	<i>1</i>	<i>10</i>	<i>5</i>	<i>50</i>
Streaming Media	<input checked="" type="checkbox"/>	<input checked="" type="checkbox"/>	<input type="checkbox"/>	<input type="checkbox"/>	<input checked="" type="checkbox"/>	<input checked="" type="checkbox"/>
	<input checked="" type="checkbox"/> Recommended	<input checked="" type="checkbox"/> Not Recommended		<input type="checkbox"/> Possible		

Recommended:

- RAID 5 – Recommended for streaming media servers that require maximum storage capacity and moderate protection and performance. This is the recommended RAID configuration for stand alone streaming media servers.

- RAID 50 – Recommended for those solutions that require a balance between storage capacity and performance. This solution provides greater availability and redundancy but less storage capacity.
- RAID 0 – While not redundant, this solution may be useful for streaming media servers that require better performance and are members of a cluster of servers where availability and redundancy are handled at a higher level.

Possible:

- RAID 1, RAID 10 – Possible in situations which do not require high storage capacity. In general servers utilized for streaming media require large amounts of storage capacity for content, especially uncompressed video.

Not Recommended:

- Concatenated – This solution is not recommended due to lack of redundancy and limited performance.

Note: While these configurations are not recommended, they can be configured and utilized.

Hot Spares

Hot Spare functionality provides extra security, availability and redundancy by automatically replacing a failed physical disk in a RAID group and allowing the rebuild of the degraded array to begin immediately. PERC 5/E controllers support Hot Spare functionality and it is recommended whenever possible.

8. Summary and Conclusions

It is important to understand the characteristics of each storage component in order to assess the performance of the overall application. It is also necessary to understand how the storage component is configured since this has a direct impact on the effectiveness of an application. Table 8-1 summarizes typical storage recommendations for various applications. Recommendations listed in the table are general conclusions and the actual storage solution may have additional factors which need to be considered before determining an optimal solution. Additional factors could include:

- Data and power back-up strategies of an Enterprise IT
- Storage deployment environment:
 - Number of active and passive users
 - Type of data – mission critical or non-mission critical
- Storage deployment budget
- Long term storage consolidation strategy

Table 18: Typical Storage Recommendation for Different Storage Applications

Application		Storage Recommendations			Remarks
<i>Servers</i>	<i>Key Parameters</i>	<i>RAID Level</i>	<i>PowerVault MD1000</i>	<i>Host Controller</i>	
Email	Availability Performance Scalability	RAID 10 provides both availability and performance	Daisy-chaining provides capacity scalability	For added performance enable Write back cache	Recommendation targets a typical enterprise e-mail Server
Database	Availability	RAID 10 provides	Daisy-chaining	For added	Performance

	Performance	both availability and performance	provides capacity scalability	performance enable Write back cache	requirements for database servers depend on number of users
Web	Performance	RAID 0 in Web Server farms provides maximum performance of all RAID levels	Split Topology spanning RAID 0 across channels provides better performance if daisy-chaining for additional capacity is not required	Enable read ahead capabilities for added performance boost	Web server farms, usually have multiple servers providing replicated web data. Thus, data availability is handled at server level
On-line Transaction	High Availability	RAID 10 provides highest availability of all RAID levels	Daisy-chaining provides capacity scalability	For added performance enable Write back cache	Recommendation targets Enterprise applications which require higher availability than performance. In general for all OLTP, data protection is of utmost importance
File	Scalability	RAID 5 maximizing storage with some data protection	Daisy-chaining provides capacity scalability	Enable Global Hot Spare for improved availability for RAID 5	These servers usually have data backed up periodically and hence, require minimum data protection from storage components
Streaming Media	Performance	RAID 0 provides maximum performance of all RAID levels	Split Topology spanning RAID 0 across channels provides better performance if daisy-chaining for additional capacity is not required	Enable read ahead capabilities for added performance boost	Performance is of utmost importance for Streaming servers. Data on these servers is usually backed up on external media such as tape libraries or optical media - CD/DVD

9. Appendix – A: References

1. SAS Protocol [Specification](#)
(http://www.t10.org/drafts.htm#SCSI3_SAS)
2. [SFF-8470 Connector Specification](#)
(<http://www.sffcommittee.com/ns/index.html>)
3. [Beyond The 2-TB SCSI Logical Unit](#)
(http://www.dell.com/downloads/global/vectors/2004_2tblun.pdf)

10. Appendix – B: Glossary

Array – Collection of multiple physical disks to form a single logical volume

BBU – Battery Backup Unit

BIOS – Basic Input Output System

Cluster – Multi-initiator Environment with MSCS operating environment

HBA – Host Bus Adapter (non-RAID controllers)

Hot Plug – Insertion or removal of device without the need to quiescent I/Os

PERC – PowerEdge Expandable RAID Controller

RAID – Redundant Array of Inexpensive Disks or Redundant Array of Independent Disks

SAS – Serial Attached SCSI

SCSI – Small Computer System Interface

U320 – Ultra 320 (320MB/sec through put)

11. Appendix – D: Revision History

<i>Revision</i>	<i>Description</i>	<i>Date</i>	<i>Modified By</i>
A00	First Release	4/17/2006	SAS Solution Core Team